



DUBLIN VILLAGE APARTMENTS

PHASE I & II CONCEPTUAL DESIGN
05.18.2023



775 YARD STREET, SUITE 325
COLUMBUS, OH 43212
INFO@DESIGNWITHMA.COM
(614) 764-0407

6689 DUBLIN CENTER DRIVE
DUBLIN, OH 43017
INFO@STAVROFF.COM
(614) 764-9981

5500 NEW ALBANY RD
NEW ALBANY, OH 43054
INFO@EMHT.COM
(614) 775-4500

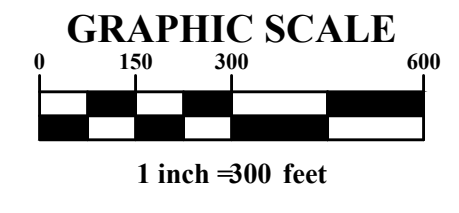

J:\20211143\Drawings\44Sheets\Concept\2023-04-26\20211143-Concept\Regional Context Map.dwg, Last Saved By: Ivanover, 5/16/2023 10:40 AM. Last Printed By: Ivanover, Linda, 5/16/2023 3:53 PM (No Xrefs)

MARK	DATE	DESCRIPTION	REVISIONS

Stavroff
STAVROFF LAND &
DEVELOPMENT, INC.

CITY OF DUBLIN, FRANKLIN COUNTY, OHIO
FOR
DUBLIN VILLAGE
REDEVELOPMENT
REGIONAL CONTEXT/VICINITY MAP

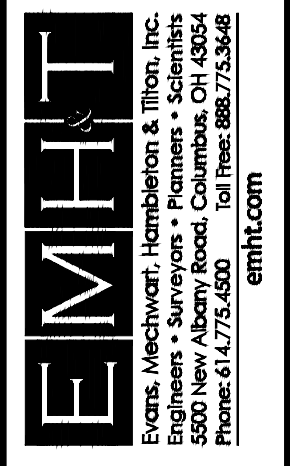

DATE	
SCALE	1" = 300'
JOB NO.	20211143
SHEET	2

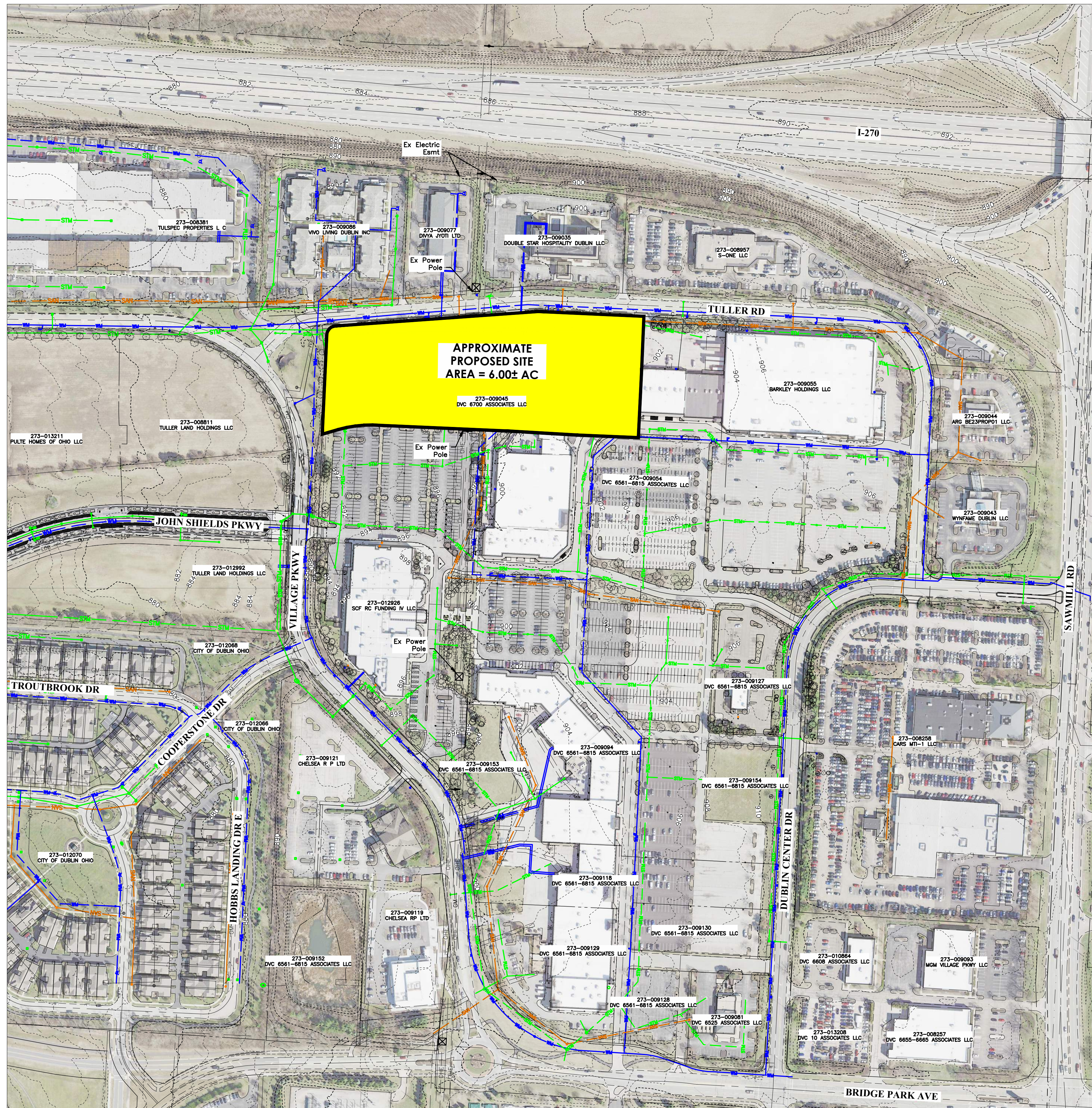

GRAPHIC SCALE

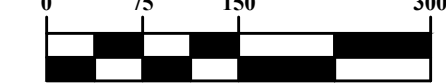

1 inch = 150 feet

LEGEND

- XXI--- Existing Contours
- XXS--- Existing Contours
- ExCB - STM - ExMH Existing Storm Sewer
- SanServ - SAN - ExMH Existing Sanitary Sewer
- ExWater Serv - ExFH Existing Watermain
- ExViv - WM - Existing Watermain
- GM--- Existing Gas Line
- OHE--- Existing Overhead Elec

APPROXIMATE PROPOSED SITE
AREA = 6.00± AC

MARK	DATE	DESCRIPTION

REVISIONS

CITY OF DUBLIN, FRANKLIN COUNTY, OHIO
CONCEPT PLAN

Stavroff
STAVROFF LAND & DEVELOPMENT, INC.

DUBLIN VILLAGE REDEVELOPMENT EXISTING CONDITIONS (OVERALL)



DATE

SCALE

1" = 150'

JOB NO.

20211143

SHEET

3

J:\20211143\Drawings\Concept\2023-04-26\20211143-ONCP-Existing Conditions(Overall).dwg, Last Saved By: Ivanover, 5/16/2023 10:40 AM Last Printed By: Ivanover, Linda, 5/16/2023 5:45 PM (No Xrefs)

J:\20211143\Drawings\4Sheets\Concept\2023-04-26-26-20211143-ONCP-Existing Conditions(Site).dwg, Last Saved By: Ivanover, 5/16/2023 4:26 PM Last Printed By: Ivanover, Linda, 5/17/2023 1:08 PM (No Xrefs)

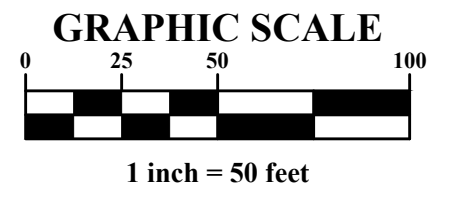
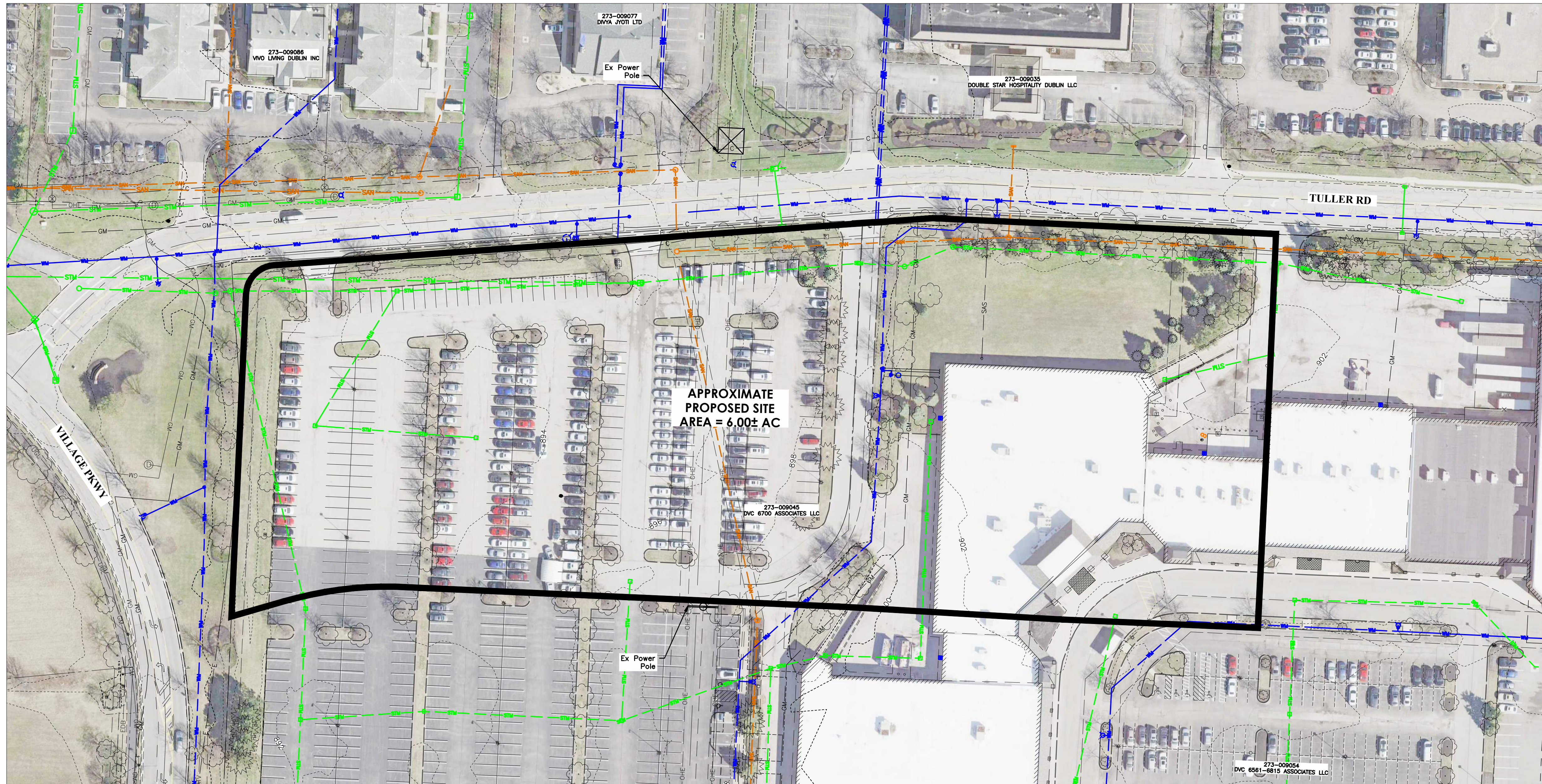

LEGEND

---XX1---	Existing Contours
ExCB - STM - ExMH	Existing Storm Sewer
SanServ - SAN - ExMH	Existing Sanitary Sewer
ExWater Serv - WM - ExFH	Existing Watermain
GM	Existing Gas Line
OHE	Existing Overhead Elec

MARK	DATE	DESCRIPTION

REVISIONS

CITY OF DUBLIN, FRANKLIN COUNTY, OHIO
CONCEPT PLAN

FOR
DUBLIN VILLAGE REDEVELOPMENT (SITE)
EXISTING CONDITIONS (SITE)

SHEET

4

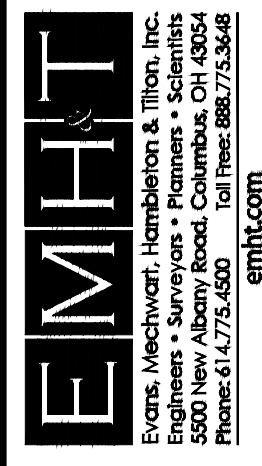

DATE

SCALE

1" = 50'

JOB NO.

20211143

DATE

20211143

DATE

20211143

Stavroff
STAVROFF LAND & DEVELOPMENT, INC.

J:\20211143\Drawings\45sheets\Concept\2023-04-26-20211143-ONCP-Proposed Demolition Limits.dwg, Last Saved By: Ivanover, 5/16/2023 4:26 PM Last Printed By: Vanover, Linda, 5/17/2023 4:17 PM (No Xrefs)

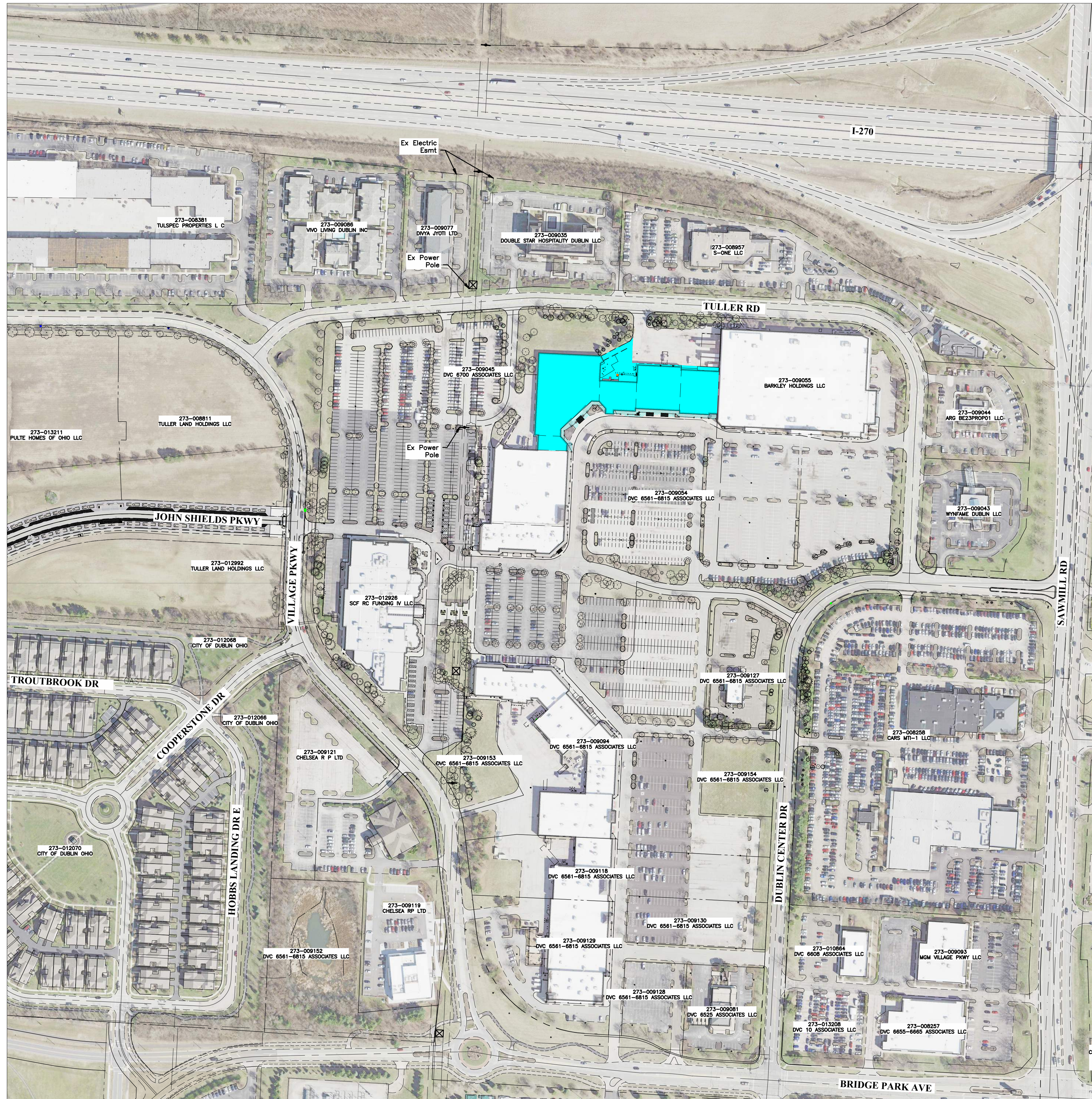

GRAPHIC SCALE

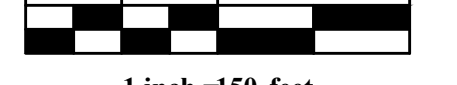

1 inch = 150 feet

LEGEND

- ExCB — STM — ExMH Existing Storm Sewer
- SanServ — SAN — ExMH Existing Sanitary Sewer
- ExWater Serv — WM — ExFH Existing Watermain
- ExViv — — Existing Gas Line
- GM — Existing Gas Line
- OHE — Existing Overhead Elec
- Proposed Demolition Limits

REVISIONS

MARK DATE DESCRIPTION

CITY OF DUBLIN, FRANKLIN COUNTY, OHIO
CONCEPT PLAN

DUBLIN VILLAGE REDEVELOPMENT LIMITS
PROPOSED DEMOLITION LIMITS

SHEET

Stavroff
STAVROFF LAND &
DEVELOPMENT, INC.

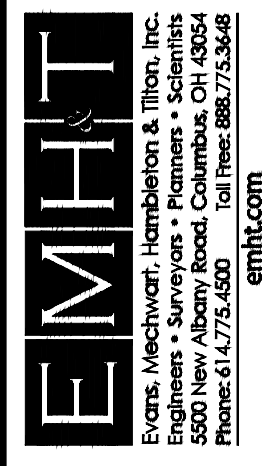

DATE

SCALE

1" = 150'

JOB NO.

20211143

SHEET

5

J:\20211143\Drawings\Concept\2023-05-18\20211143-GNCP-Open Space Exhibit.dwg, Last Saved By: emonti, 5/26/2023 1:10 PM, Last Printed By: Monti, Emily, 5/26/2023 1:11 PM
 5_xrefs: 20211143-GS-Town-GIS-F, 20211143-GS-REFER-N, 20211143-GS-REFER-O, MWA, Block, 2022-07-28, 1st Floor

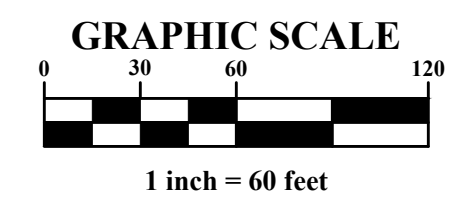
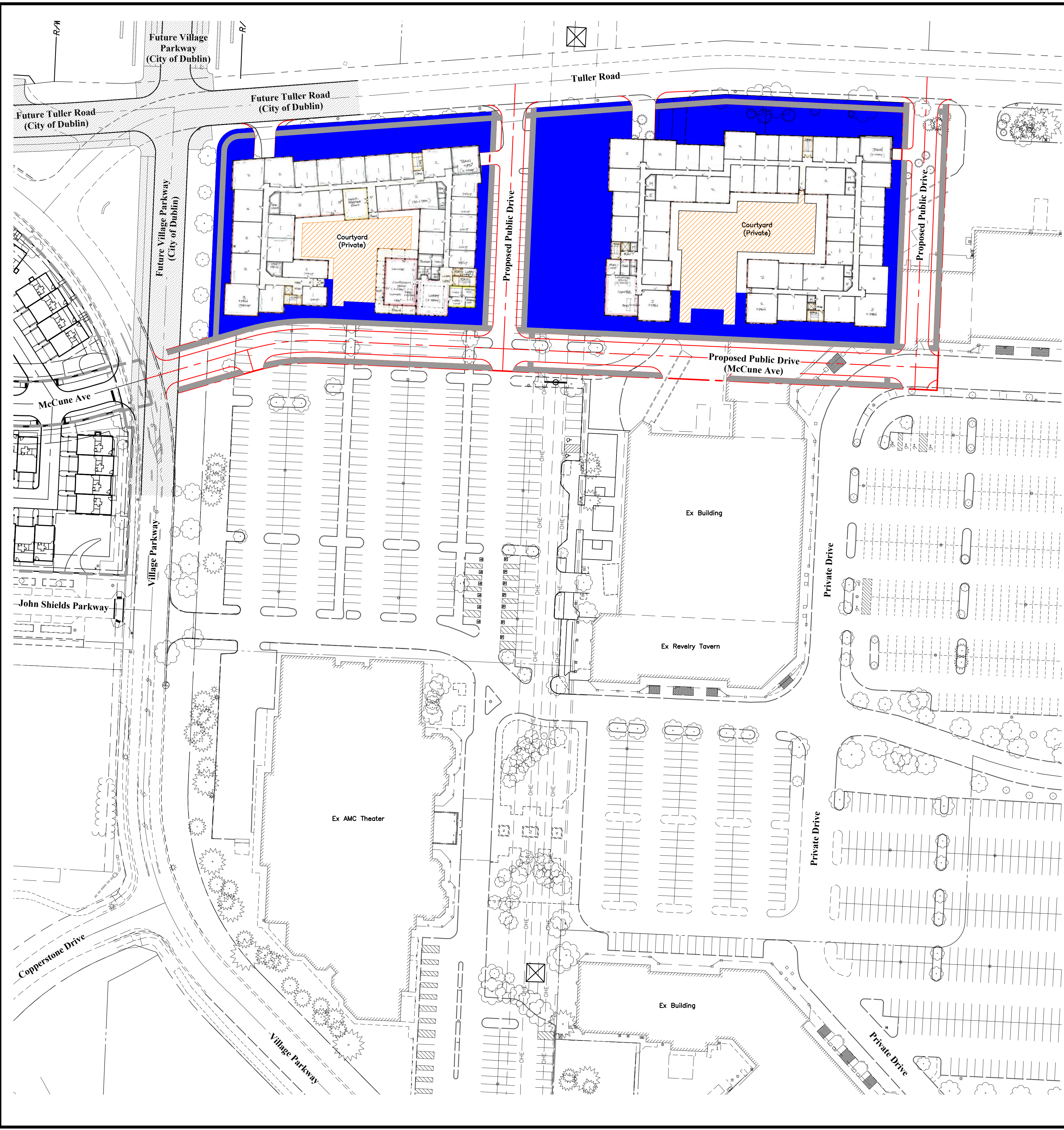

Required	
Residential Required Area (Ph 1)	125 units x 200 sf/unit =25,000 sf =0.57 Acres
Residential Required Area (Ph 2)	160 units x 200 sf/unit =32,000 sf =0.73 Acres
Total Required Open Space Area	±1.30 Acres
Provided	
Public Open Space (Ph 1)	±0.45 Acres
Public Open Space (Ph 2)	±1.01 Acres
Total Open Space	±1.46 Acres
Roof Amenity Deck (Ph 1)	±0.16 Acres
Roof Amenity Deck (Ph 2)	±0.29 Acres
Total Roof Amenity Deck	±0.45 Acres
Total Provided Open Space Area (With Roof Amenity Deck)	±1.92 Acres
Total Provided Open Space Area (Without Roof Amenity Deck)	±1.46 Acres
Proposed 6' Public Concrete Sidewalk	

MARK	DATE	DESCRIPTION

Stavroff
 STAVROFF LAND &
 DEVELOPMENT, INC.

CITY OF DUBLIN, FRANKLIN COUNTY, OHIO
 FOR
DUBLIN VILLAGE
REDEVELOPMENT
OPEN SPACE EXHIBIT

EMHT
 Engineers • Surveyors • Planners • Scientists
 5500 New Albany Road, Columbus, OH 43254
 Phone: 614.775.5500 Fax: 614.775.3656
 emht.com

DATE

SCALE
 1" = 60'

JOB NO.
 20211143

SHEET
 6

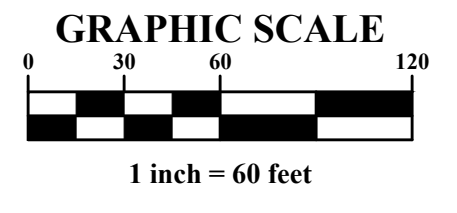
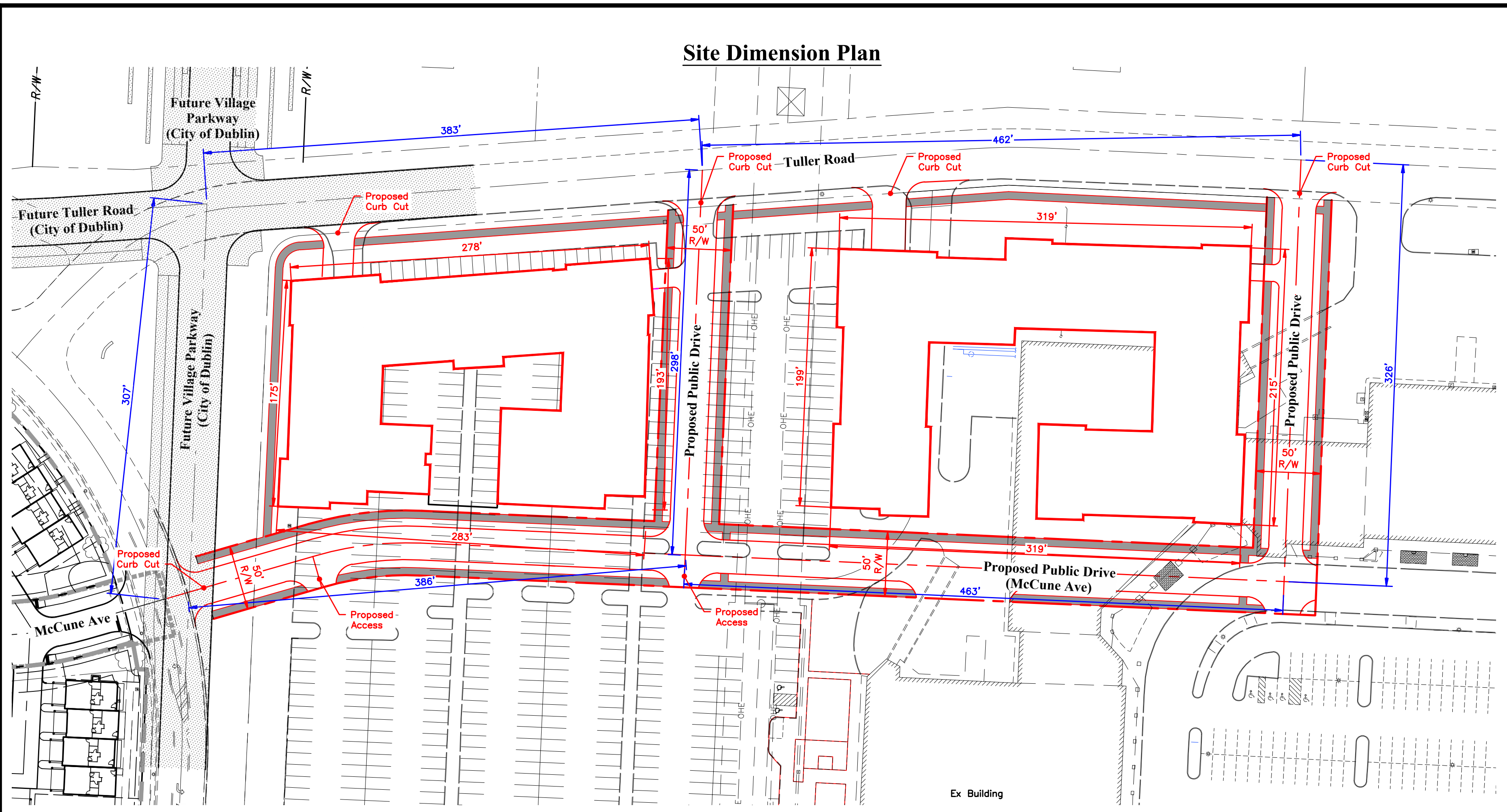

LEGEND

	Proposed 6' Public Concrete Sidewalk
	Existing Watermain
	Proposed Watermain
	Fire Hydrant
	Fire Department Connection
	Existing Overhead Elec

NOTE:
Layout/utilities are shown for preliminary planning purposes and subject to change.

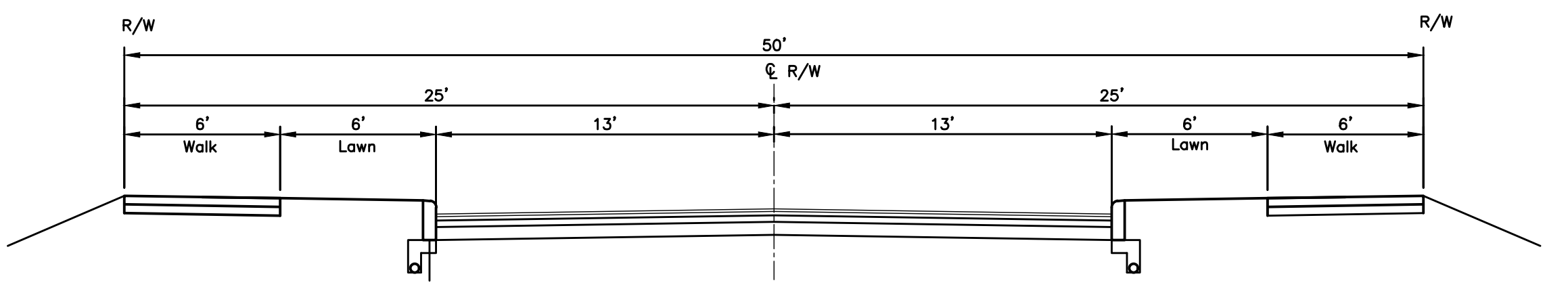

Preliminary Public Street Typical Section (50' R/W)

Not To Scale

NOTE:
On Street Parking Provided Where Feasible

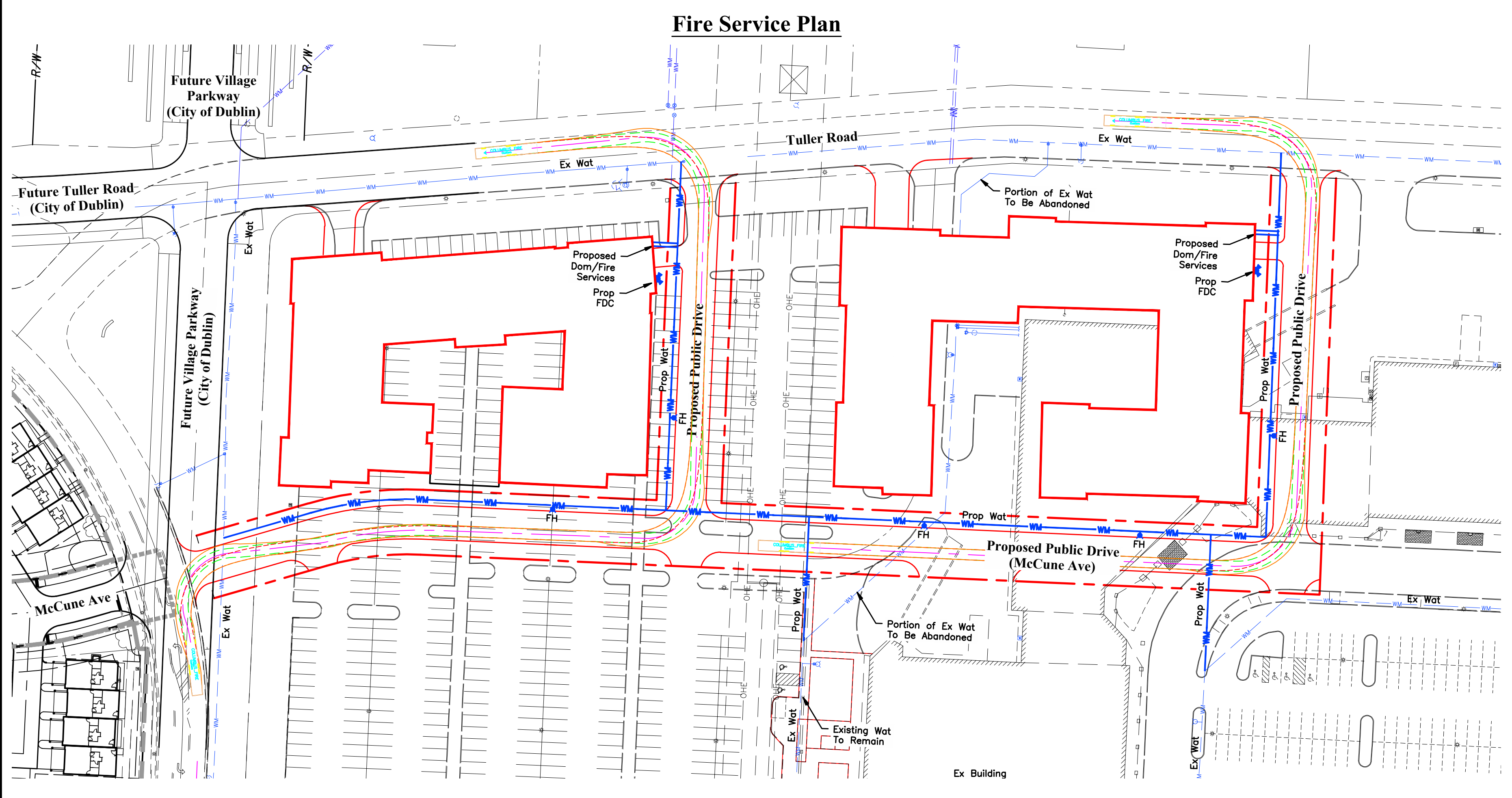

MARK	DATE	DESCRIPTION

Stavroff
STAVROFF LAND & DEVELOPMENT, INC.

CITY OF DUBLIN, FRANKLIN COUNTY, OHIO
FOR
DUBLIN VILLAGE
REDEVELOPMENT
SITE PLAN EXHIBIT

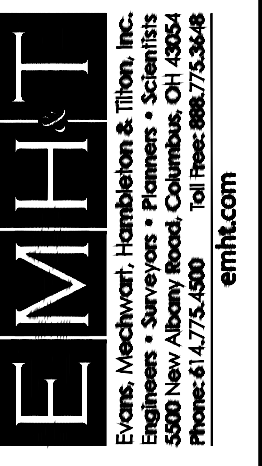

DATE	
SCALE	1" = 60'
JOB NO.	20211143
SHEET	7

J:\20211143\Drawings\Concept\2023-05-18\20211143-GNCP-Site Plan Exhibit.dwg, Last Saved By: emonti, 5/26/2023 1:01 PM, Last Printed By: Monti, Emily, 5/26/2023 1:05 PM
 \$Xrefs: 20211143-GS-Topo-GIS-F, 20211143-GS-REFR-GIS-F, 20211143-GS-REFR-N, 20211143-GS-REFR-O, MKA Block 2022-07-28(1st Floor)

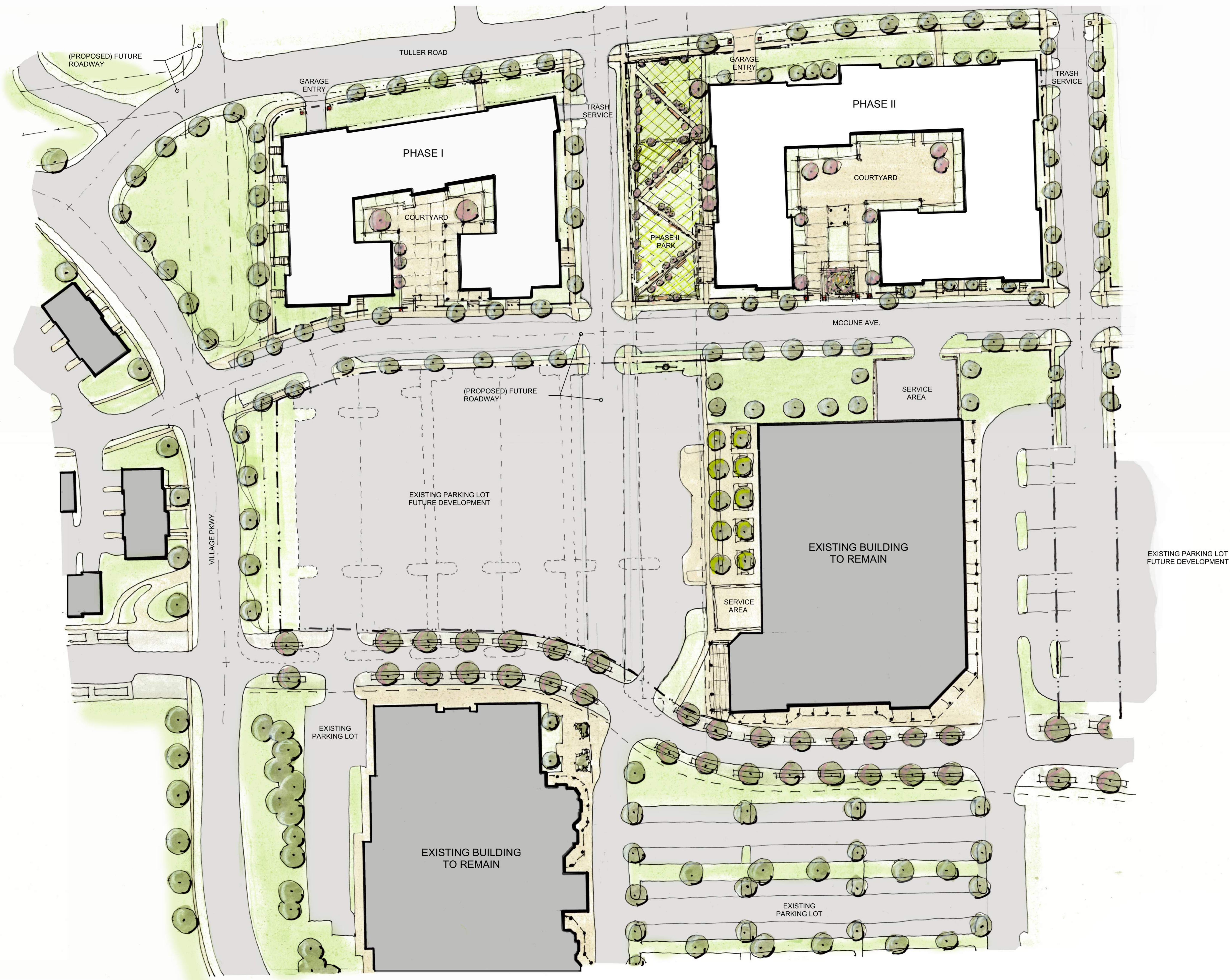

PHASE I - 124 UNITS
147 PARKING SPACES REQUIRED
153 PARKING SPACES PROVIDED
(20 ON STREET / 133 GARAGE)

PHASE II - 160 UNITS
190 PARKING SPACES REQUIRED
207 PARKING SPACES PROVIDED
(32 ON STREET / 175 GARAGE)

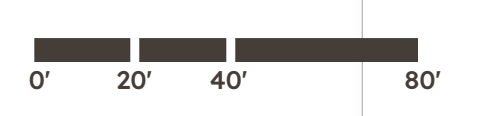
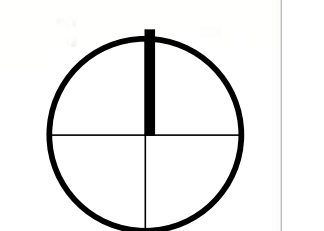

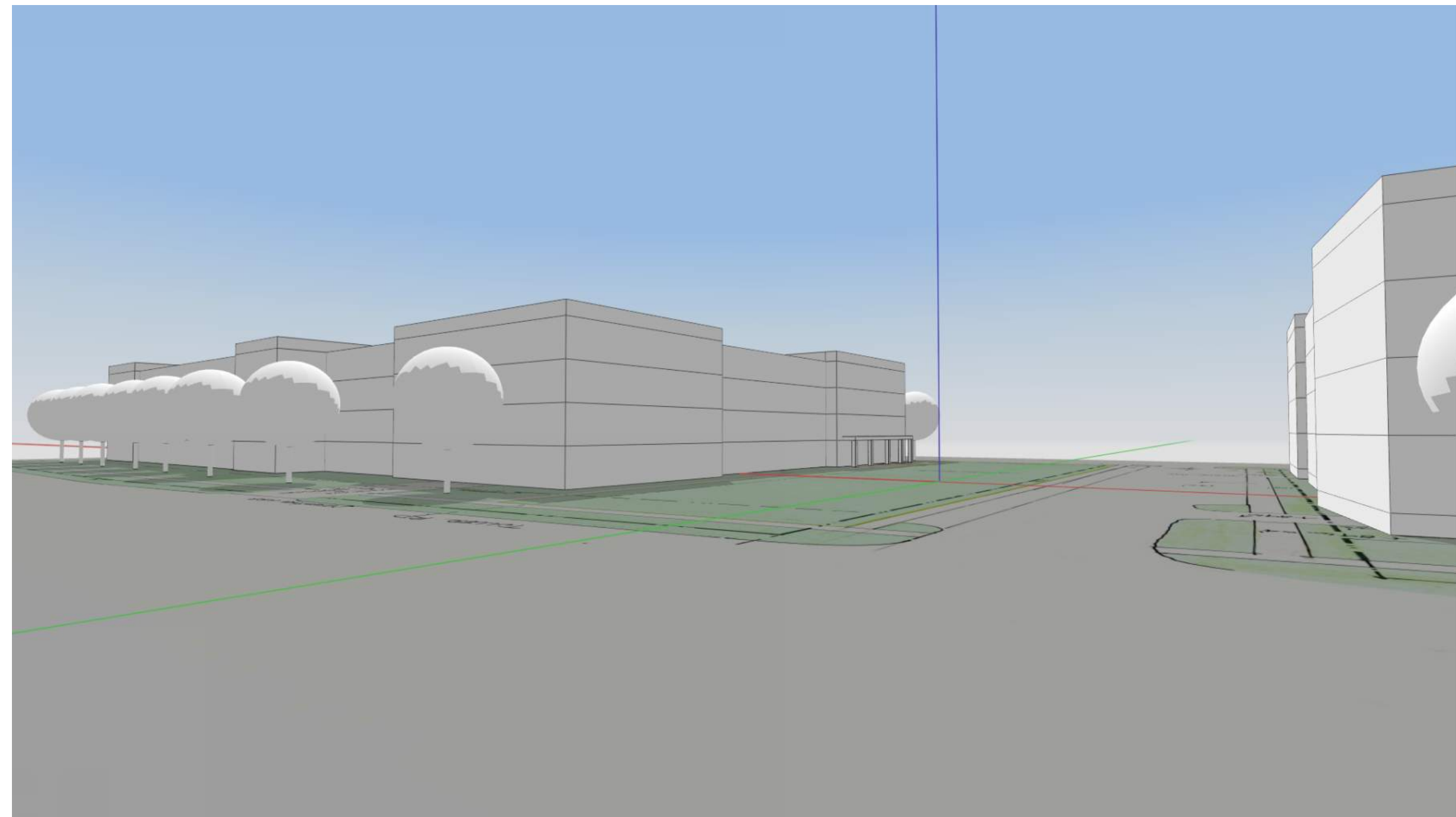
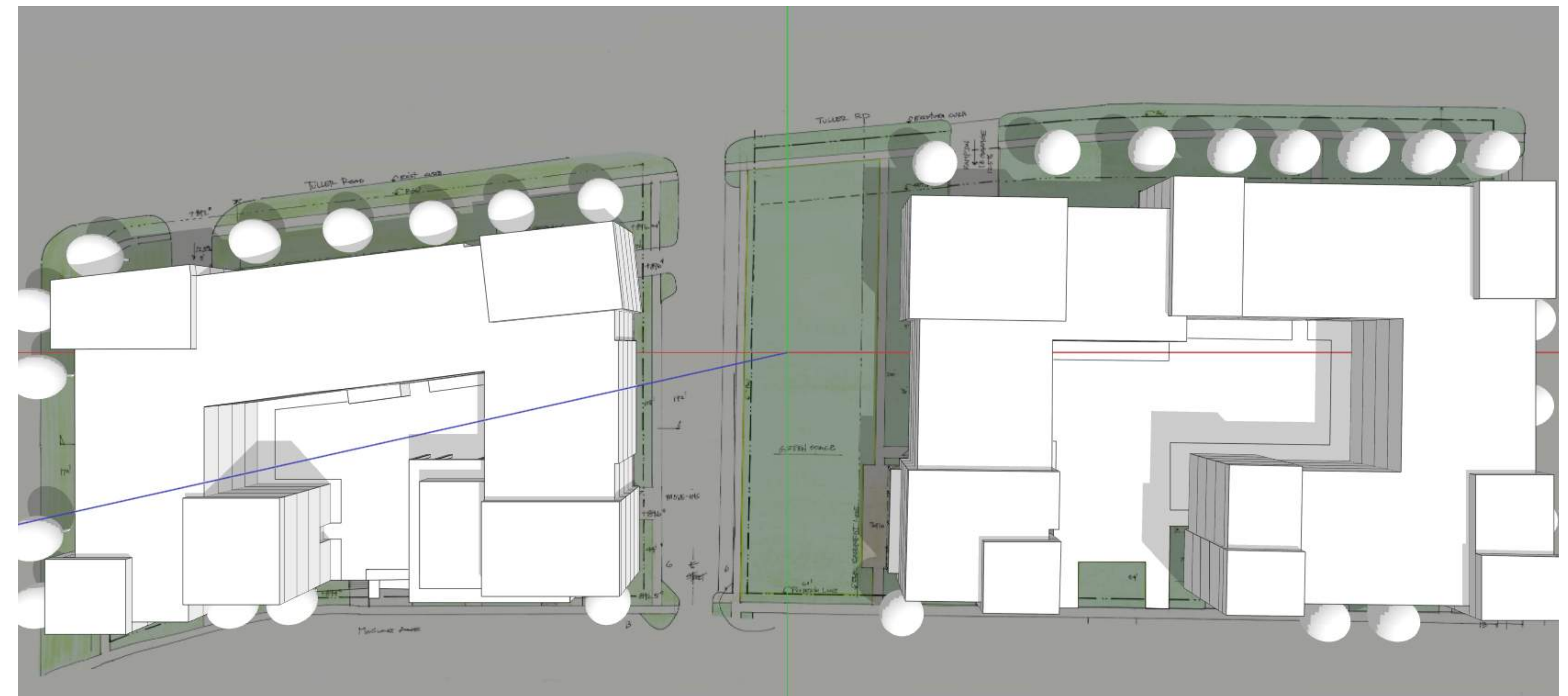
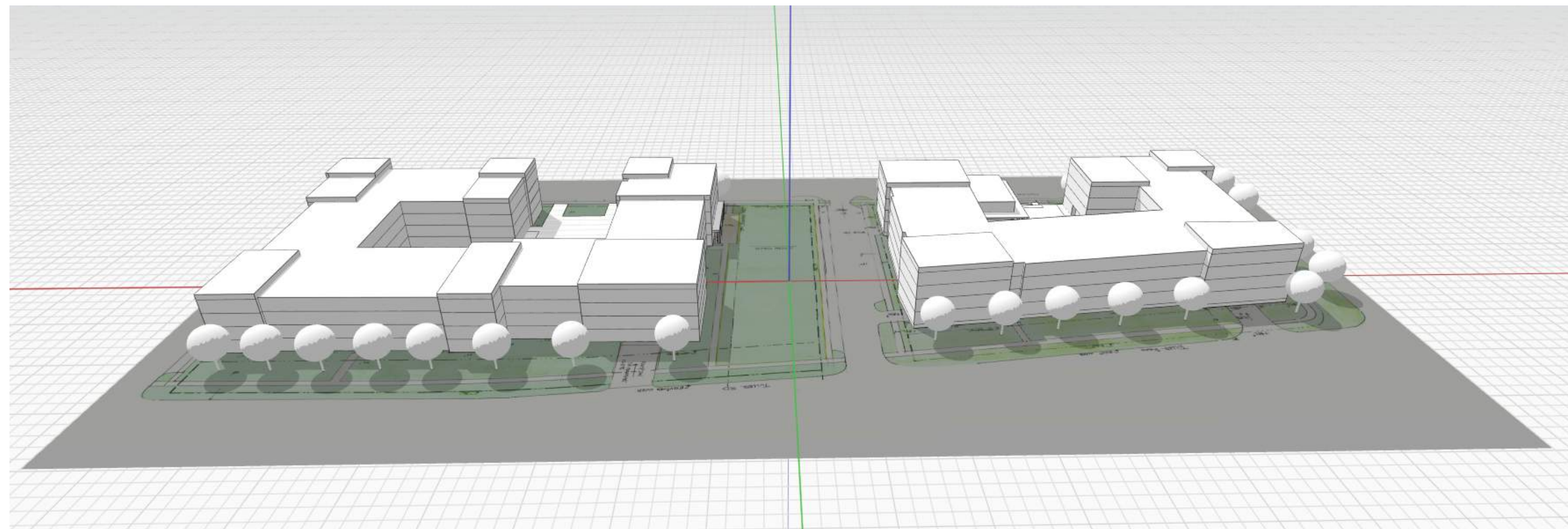
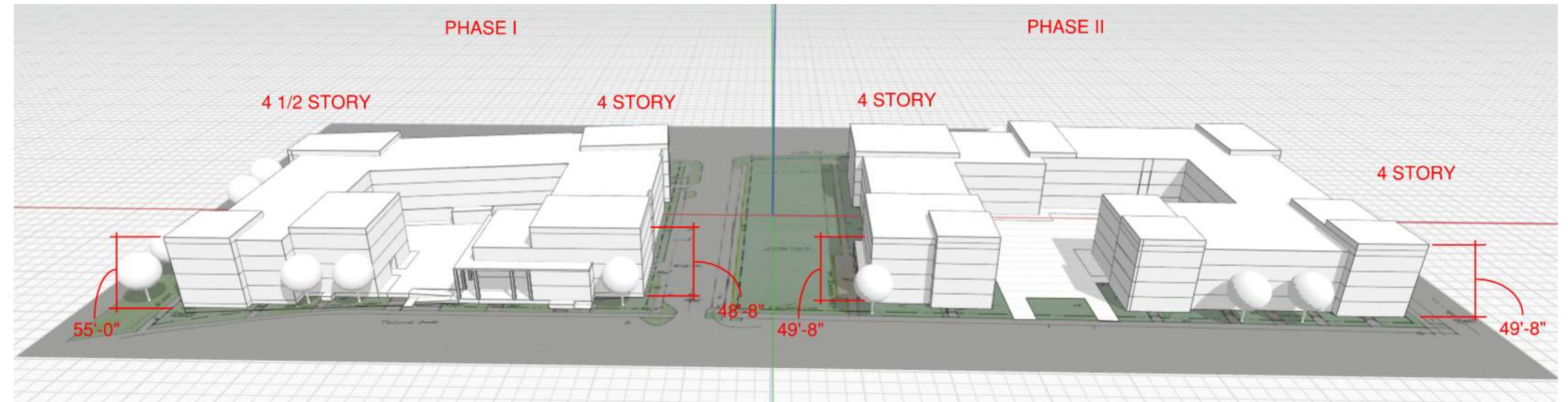

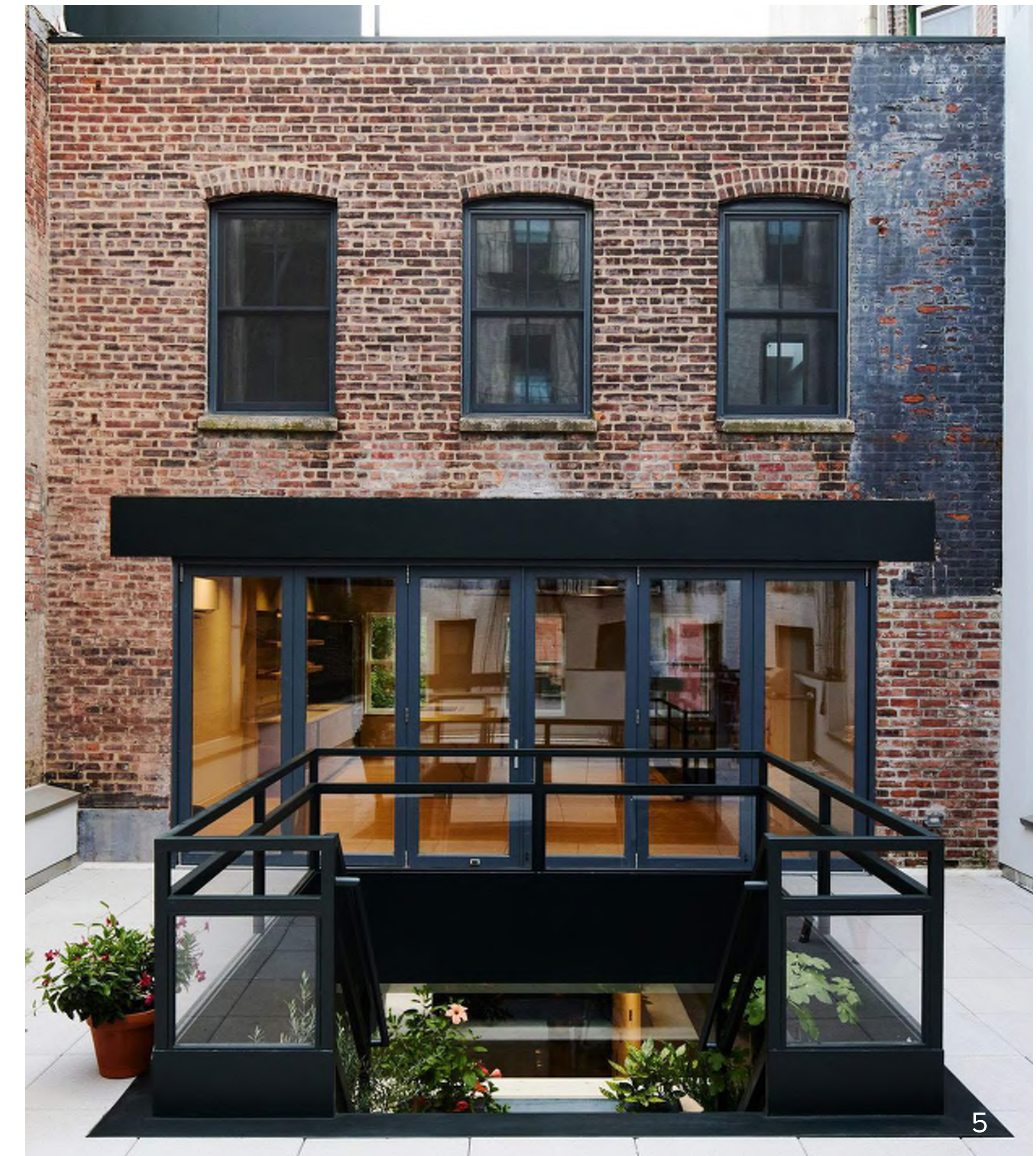



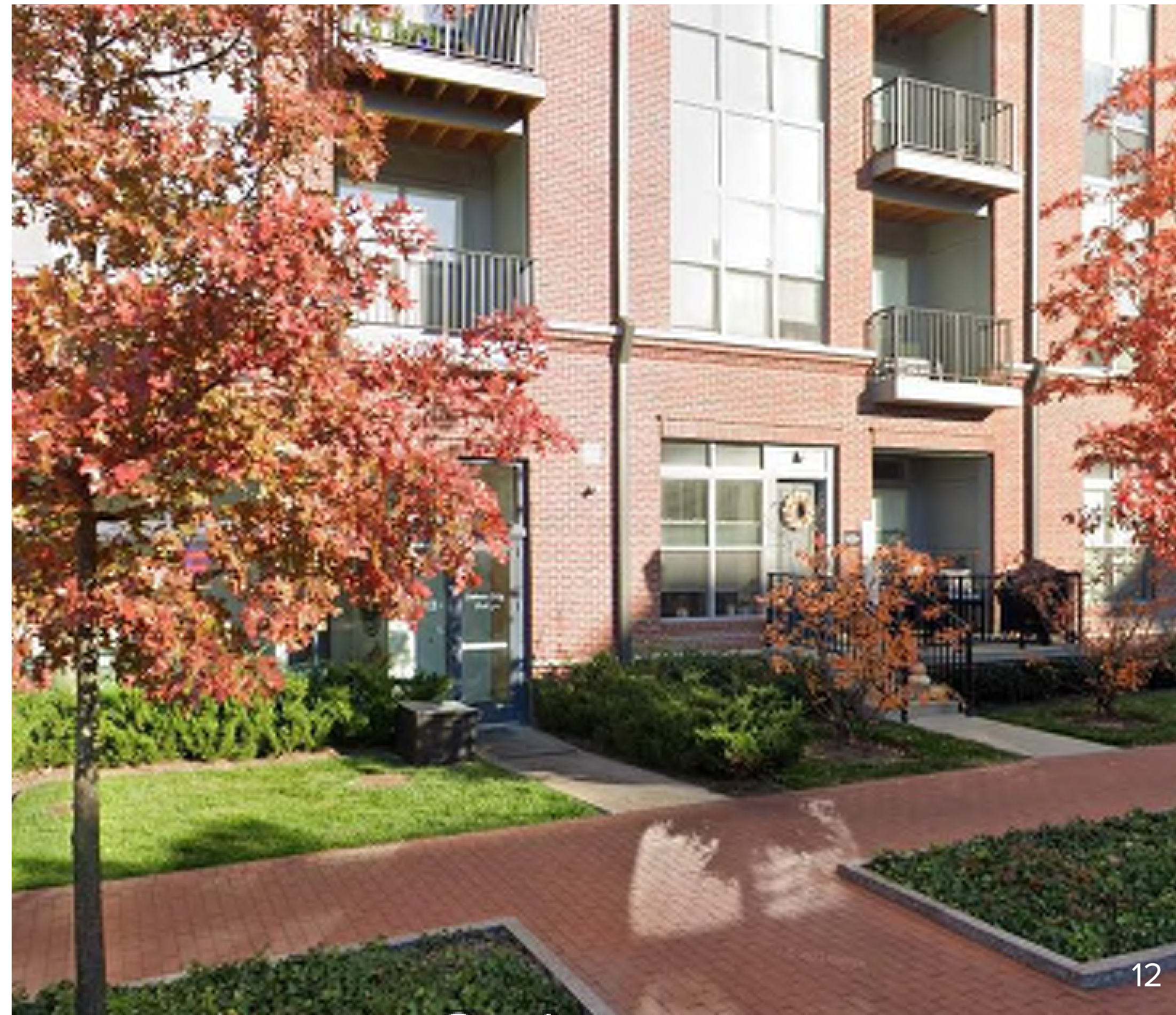



15



17



21



16



18



19



20

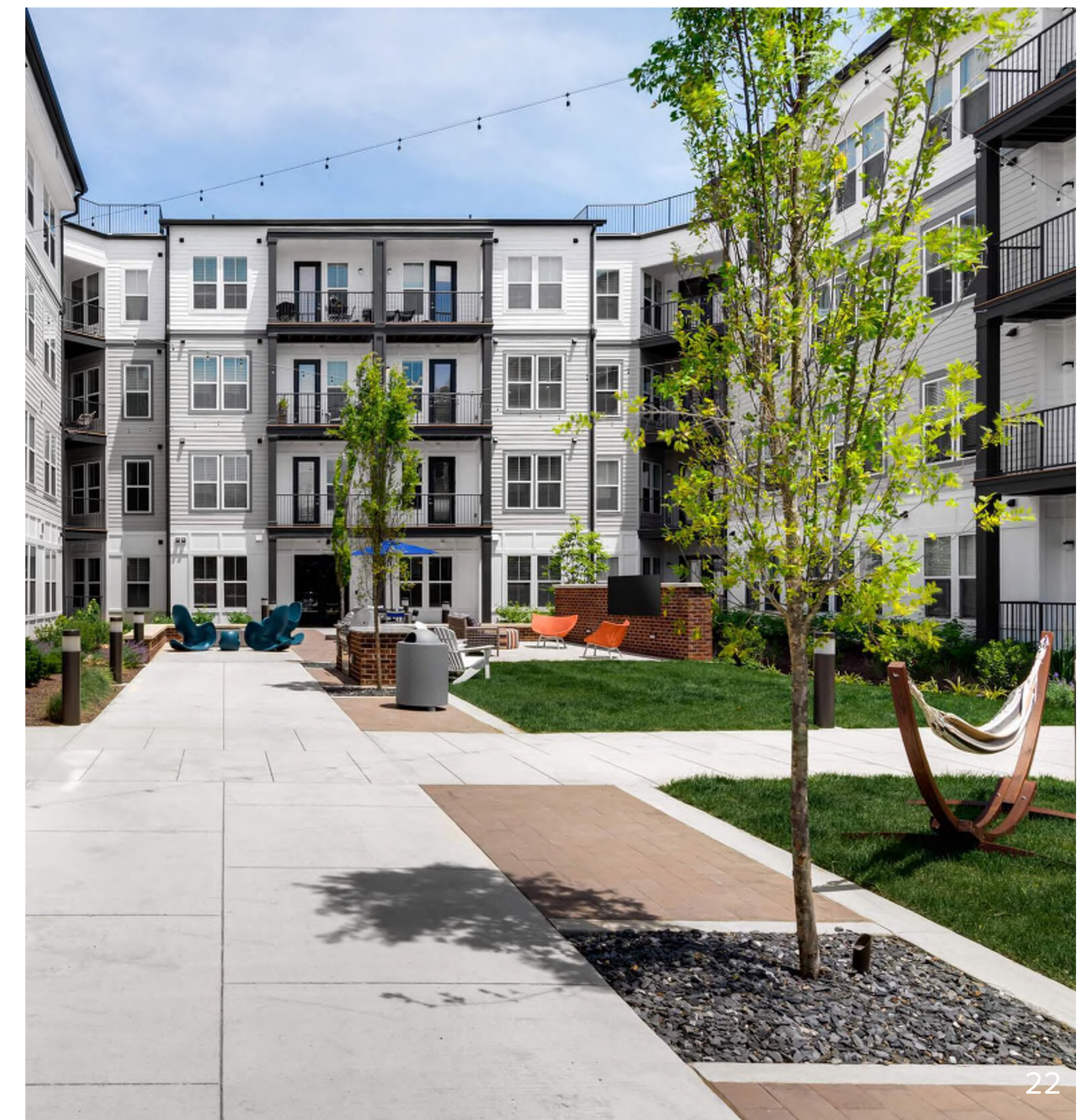

22

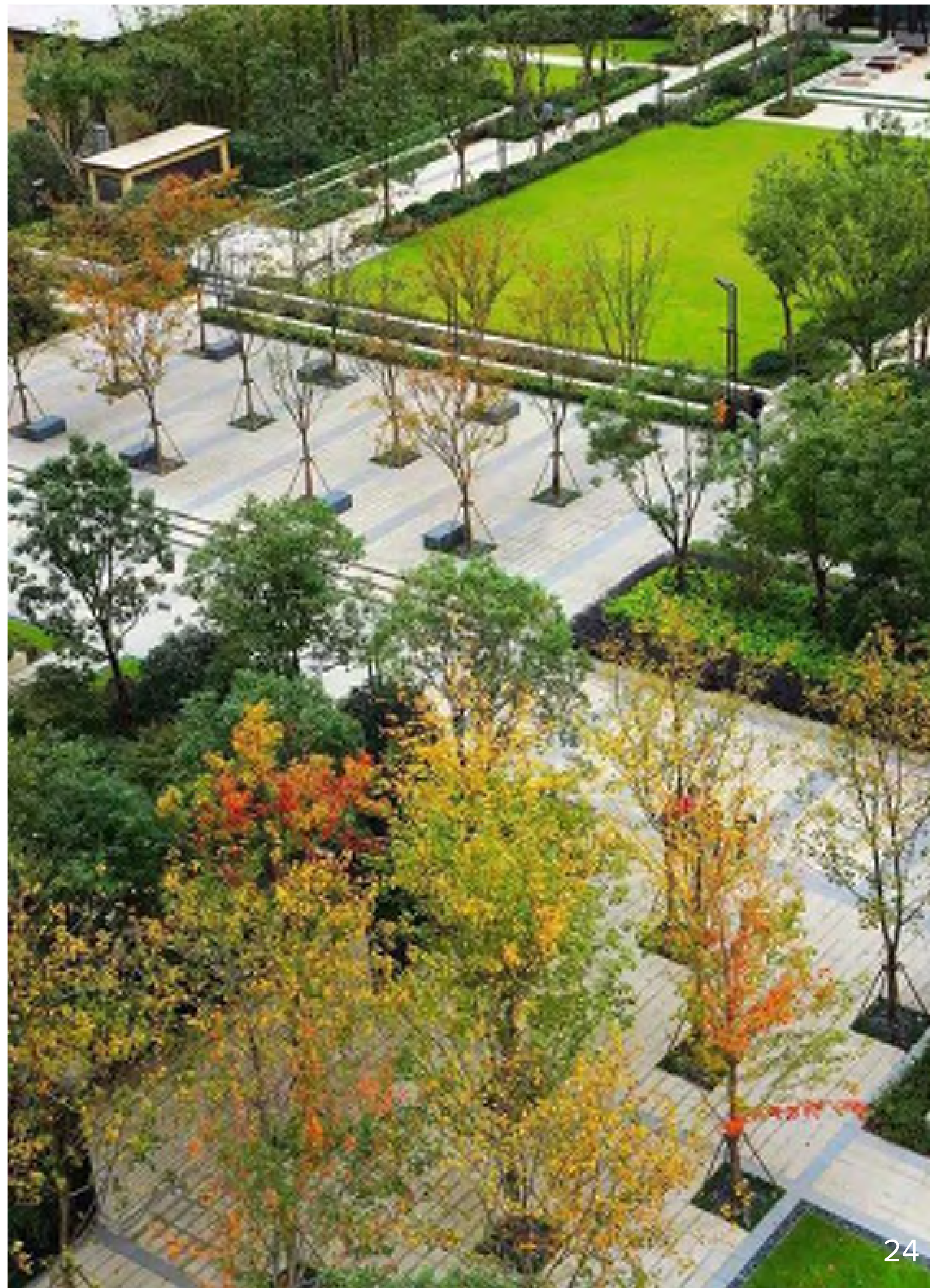



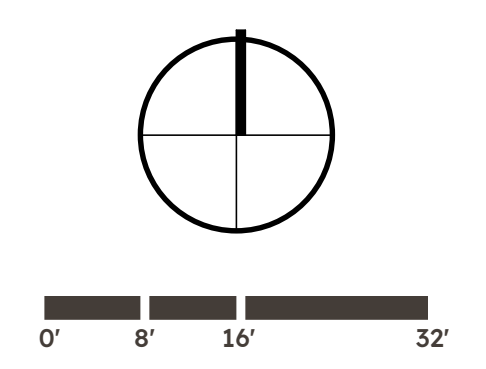
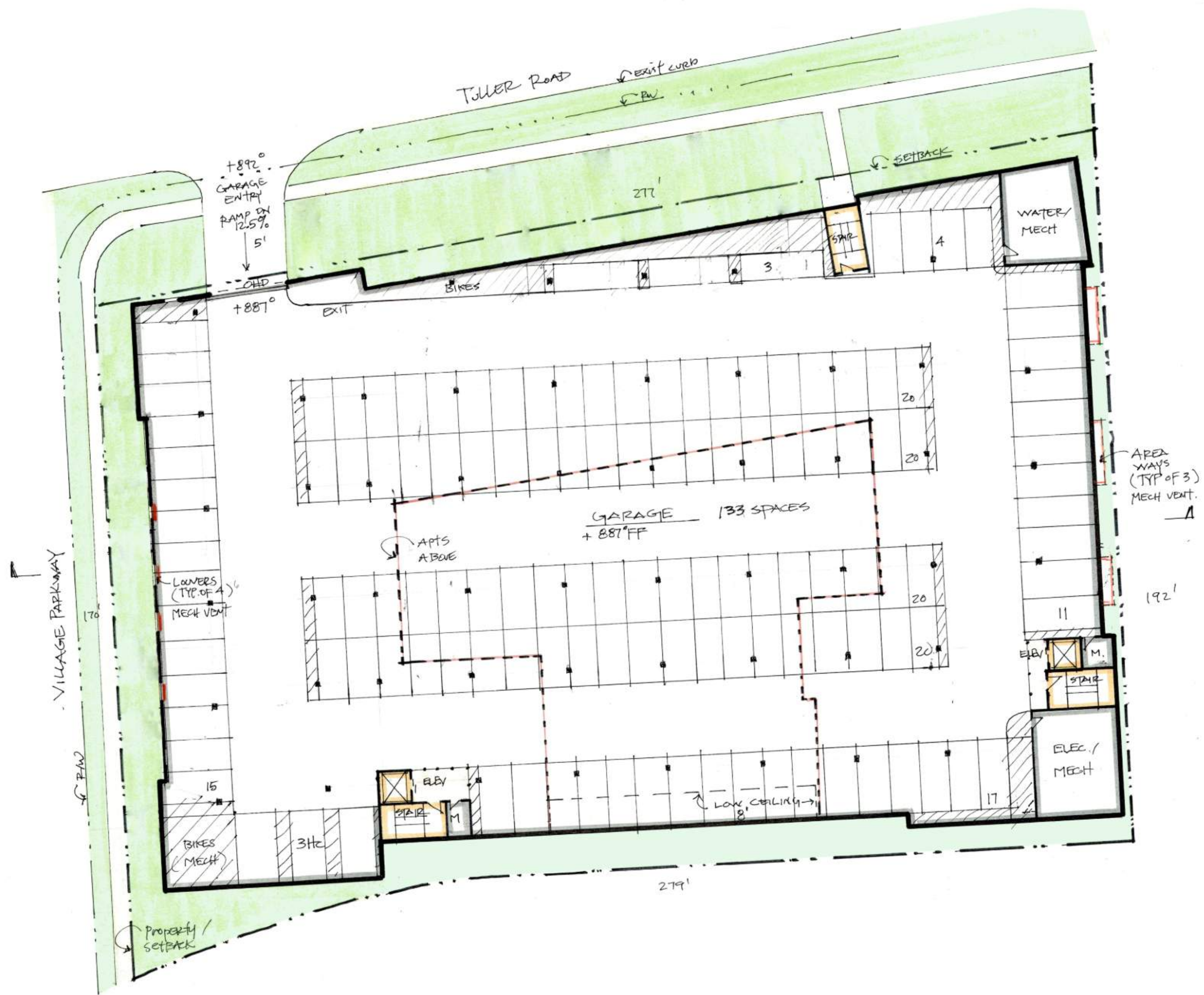

PHASE I



DVA
UNITS - PHASE I

PL	1BR	2BR	TOTAL
5	20	13	33
4	21	12	33
3	19	11	30
2	18	10	28
	78	46	124 UNITS
	63%	31%	170 BEDS

- 147 PARKING SP RECD
- 153 PARKING SP PRVD

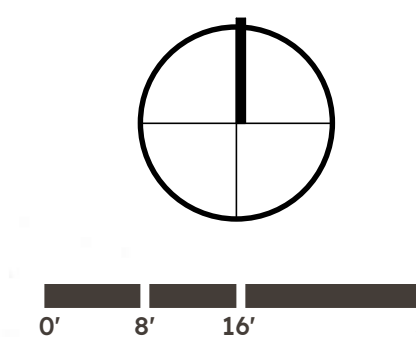

PHASE I

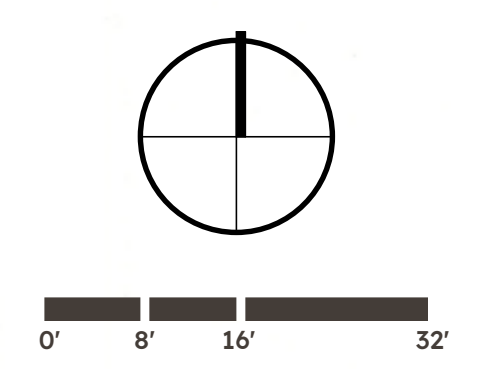

PHASE I

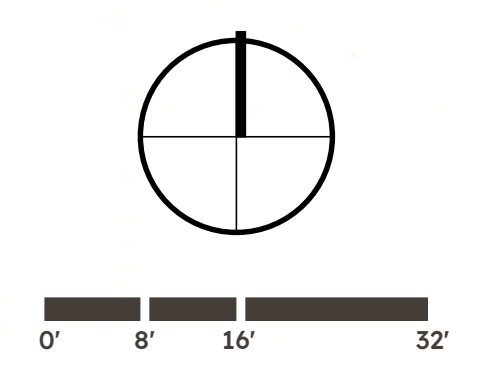

PHASE I

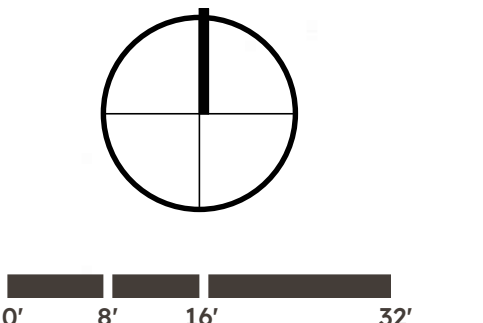
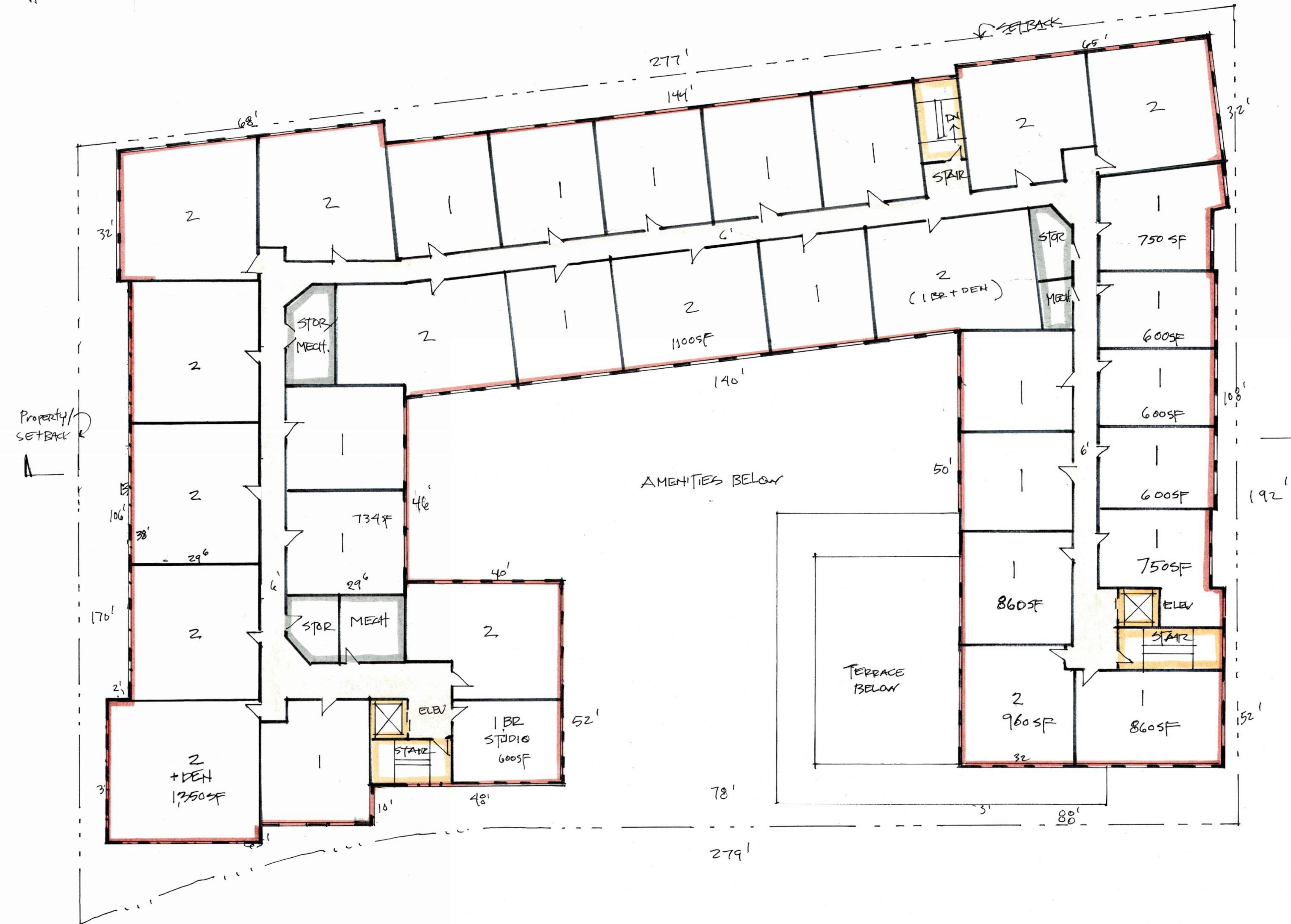
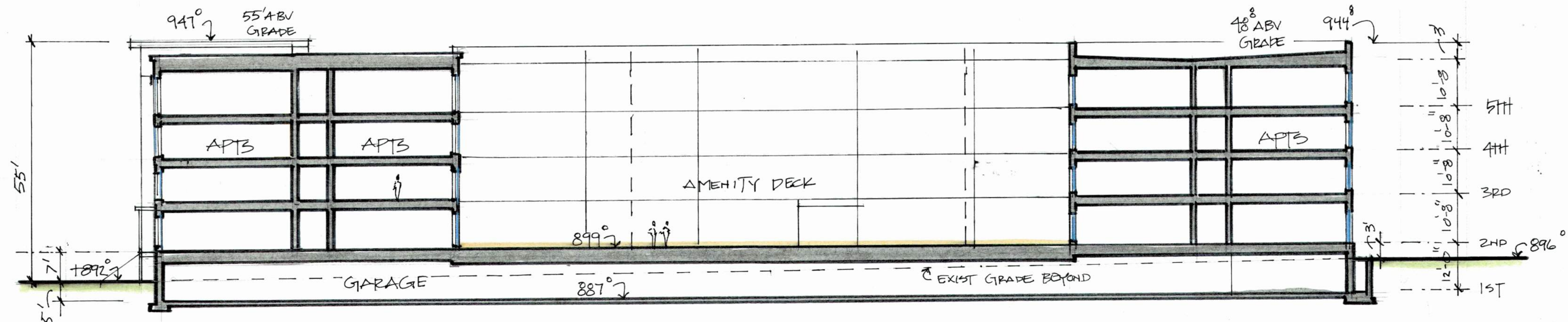

PHASE I

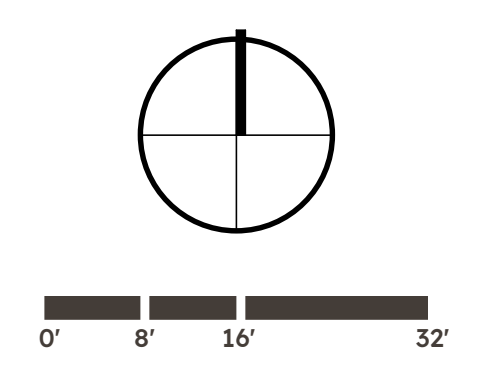
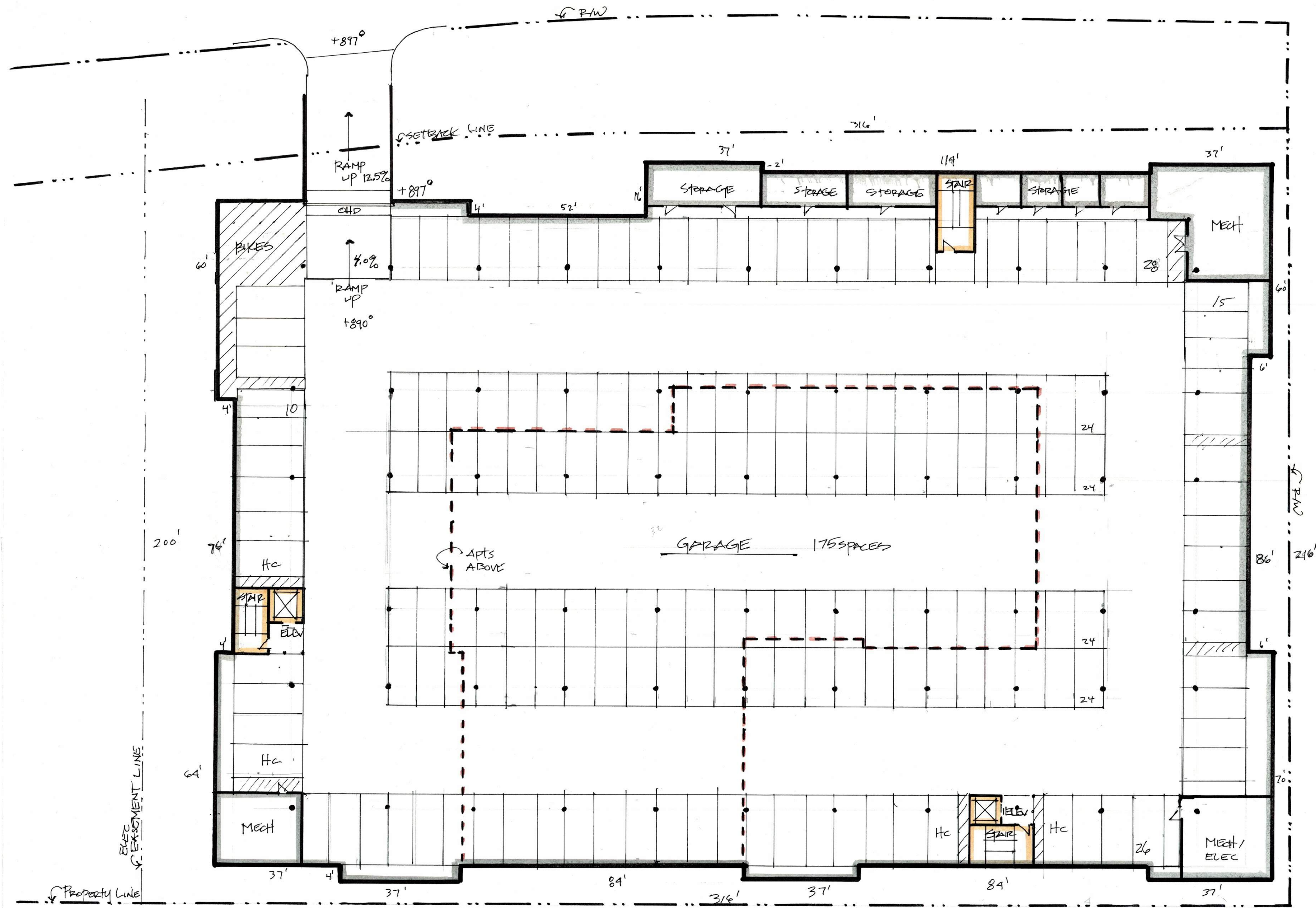

PHASE II

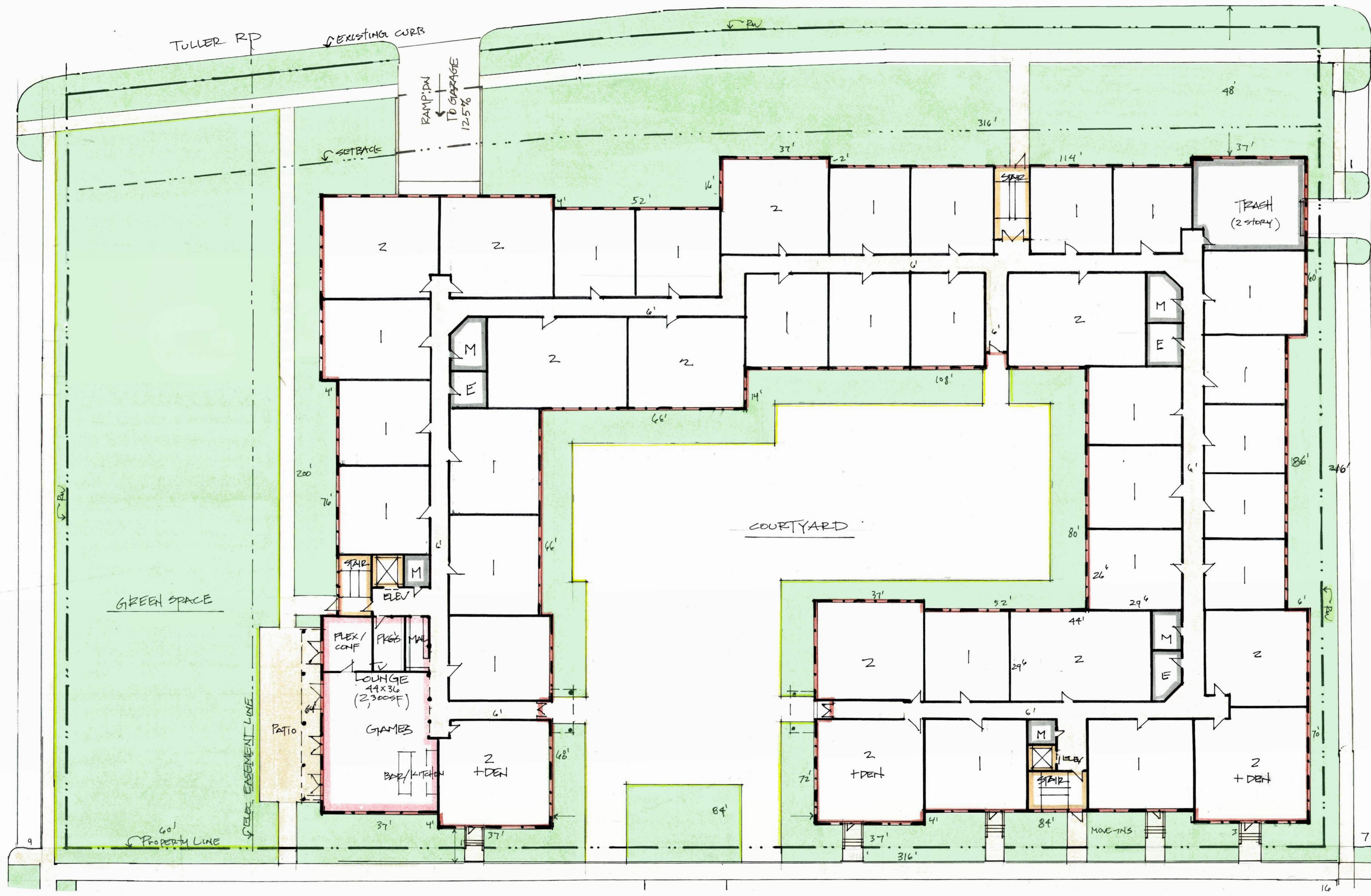

DVA UNITS - PHASE II

FL	1BR	2BR	TOTAL
5	25	16	41
4	25	16	41
3	25	15	40
2	26	12	38
			160 UNITS
			63% 37% 219 BEDS

- 190 PARKING SP REAR
- 207 PARKING SP FRONT

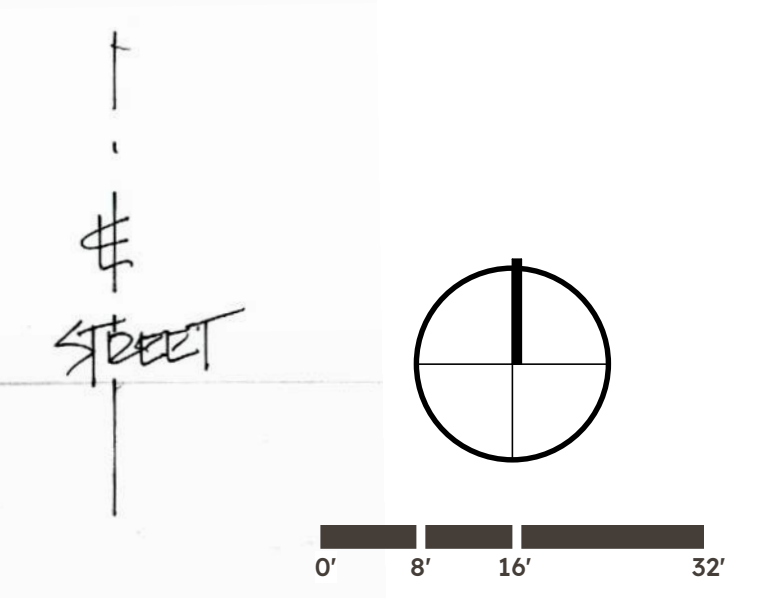

PHASE II

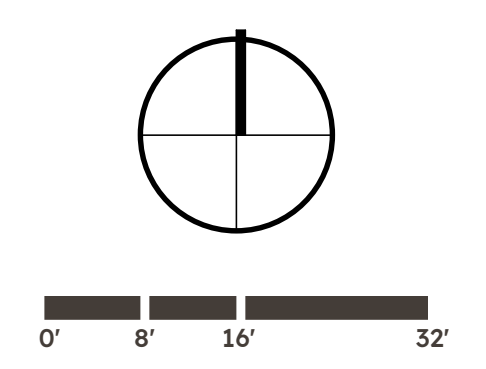

PHASE II

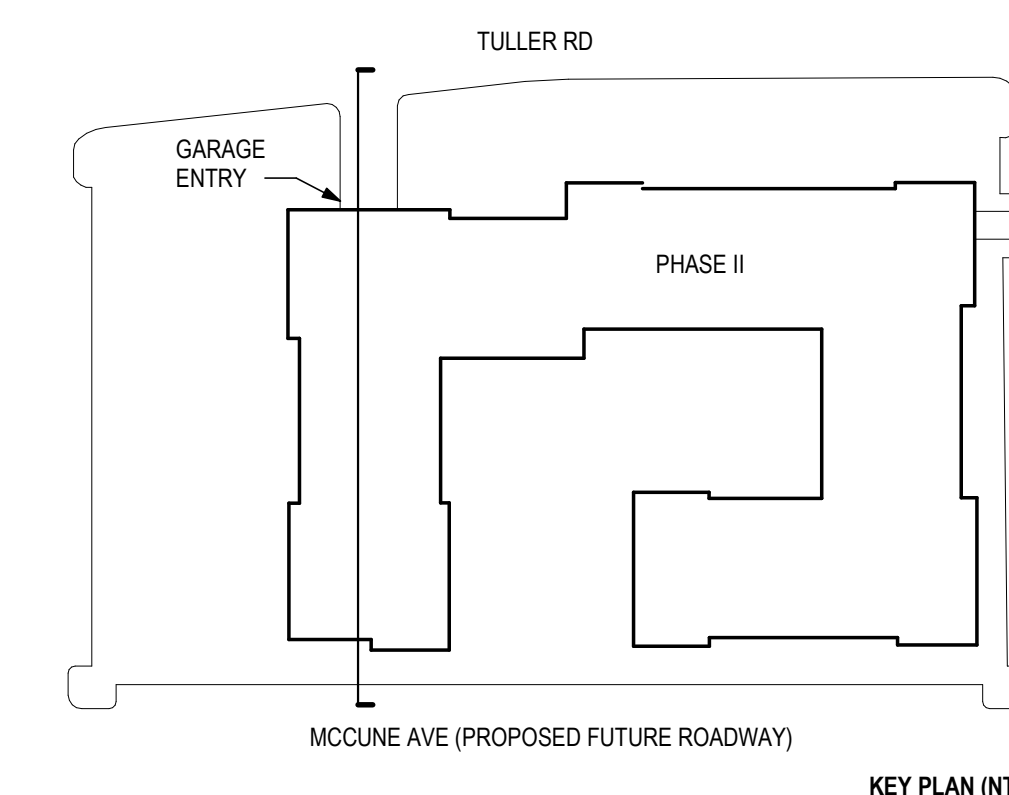
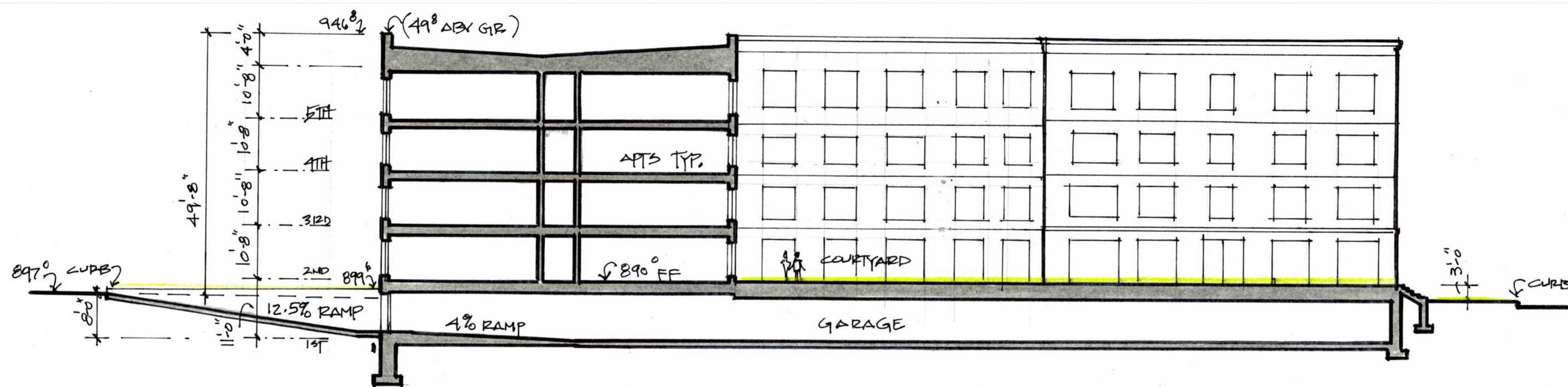

PHASE II