

DRAWING SHEET INDEX

#	Sheet name	Current Revision	Revision Date
GENERAL			
G001	Title Sheet		
G002	General Notes & Code Info.		
G003	Accessibility Guidelines		
G004	Accessibility Guidelines		
ARCHITECTURAL			
A100	Plans & Elevations		
A201	Storefront Calculations		
A300	Building Sections		

OWNER

Libby Tonucci
 6560 Longshore St.
 Dublin, OH 43017
 (614) 783-1595

ARCHITECT

Astra Studios
 470 W. Broad St.
 Columbus, OH 43215
 (614) 461-3126

GENERAL CONTRACTOR

Tenby Construction
 Two Miranova Place, Suite 910
 Columbus, OH 43215
 (614) 800-4622

PROJECT LOCATION MAP



PROJECT STATUS

MINOR PROJECT REVIEW

CURRENT ISSUE DATE

FEBRUARY 16, 2024

PROJECT NO.

23005

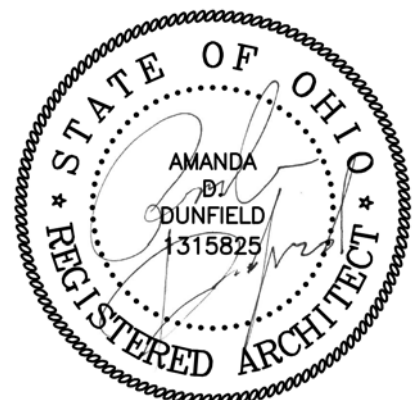

Amanda Dunfield, License
 # 1315825
 Expiration Date: December 31, 2025

REVISIONS

#	Description	Date

PROJECT INFORMATION

J.Hilburn

6560 Longshore Street
 Dublin, OH 43017

SHEET NAME

Title Sheet

SHEET NUMBER

G001

PROJECT DESCRIPTION

Replacement of an existing retail storefront.

REFERENCED CODES

2017 Ohio Building Code
2017 Ohio Mechanical Code
2017 Ohio Plumbing Code
2017 National Electric Code
2012 IECC and ASHRAE 90.1
2015 International Fuel Gas Code
2017 Ohio Fire code (NFPA 13)
2009 ICC/ANSI A117.1/ADAAG

GENERAL INFORMATION

<u>Site Information:</u>	
Jurisdiction:	City of Dublin
Parcel ID #:	273-012738-00
<u>Building Information:</u>	
No. Stores:	1
Use/Occupancy Classifications:	M
Construction Type(s):	1B
Fire Suppression:	Yes - not impacted by project scope
Fire Alarm:	Yes - not impacted by project scope
Area Impacted by Project Scope:	150sf

CHAPTER 3 - USE AND OCCUPANCY CLASSIFICATION

USE GROUP - M - PER 309.1
Mercantile Group M occupancy includes, among others, the use of a building or structure or a portion thereof for the display and sale of merchandise, and involves stocks of goods, wares or merchandise incidental to such purposes and accessible to the public.

CHAPTER 4 - SPECIAL DETAILED REQUIRMENTS

M - MERCANTILE PER 309.1
As applicable

CHAPTER 5 - GENERAL BUILDING HEIGHTS AND AREAS

TABLE 504.3 & 504.4: USE GROUP M (S), CONSTRUCTION TYPE 1B

MAX. ALLOWABLE	ACTUAL/PROPOSED
12 STORIES	1
180'	18'

TABLE 506.2: USE GROUP M (S), TYPE OF CONSTRUCTION 1B

MAX. ALLOWABLE	ACTUAL/PROPOSED
UL	150sf

CHAPTER 6 - TYPES OF CONSTRUCTION

TABLE 601: CONSTRUCTION TYPE 1B (NONCOMBUSTIBLE, UNPROTECTED)

BUILDING ELEMENT:	REQUIRED RATING:
Primary structural frame:	2
Bearing walls	
Exterior:	2
Interior:	2
Nonbearing walls and partitions	
Exterior:	See Table 602
Interior:	0
Floor construction and associated secondary members:	2
Roof construction and associated secondary members:	1
603: FIRE RETARDANT TREATED WOOD REQUIRED:	YES

CHAPTER 7 - FIRE AND SMOKE PROTECTION FEATURES

706: FIRE WALLS REQUIRED:	NO
707: FIRE BARRIERS REQUIRED:	NO
708: FIRE PARTITIONS REQUIRED:	NO
709: SMOKE BARRIERS REQUIRED:	NO
710: SMOKE PARTITIONS REQUIRED:	NO

CHAPTER 8 - INTERIOR FINISHES

TABLE 803.11: USE GROUP M, UNPROTECTED

INTERIOR EXIT STAIRWAYS AND RAMPS AND EXIT PASSAGEWAYS	B
CORRIDORS	C
ROOMS AND ENCLOSED SPACES	C

Class A: flame spread index 0-25; smoke-developed index 0-450.

Class B: flame spread index 26-75; smoke-developed index 0-450.

Class C: flame spread index 76-200; smoke-developed index 0-450.

804.4 INTERIOR FLOOR FINISH REQUIREMENTS:

- Floors shall be class I in groups I-1, I-2 and I-3. They are permitted to be reduced to class II if building is equipped throughout with an automatic sprinkler system.
- Floors shall be a minimum of class II in groups A, B, E, H, I-4, M, R-1, R-2 and S.
- All floor covering materials shall comply with the DOCFF-a "Pill Test"
- Class I: 0.45 watts/cm² or greater.
- Class II: 0.22 watts/cm² or greater.

CHAPTER 9 - FIRE PROTECTION SYSTEMS

PER 903

Existing fire protection systems are not impacted by project scope.

CHAPTER 10 - MEANS OF EGRESS

TABLE 1004.1.2: USE GROUP M

FUNCTION (PER 1004.1.2)	SF/PERSON	SF TYPE
Assembly (Dining, Tables & Chairs)	15	Net
Assembly (Standing Space)	5	Net
Business Areas	100	Gross
Kitchens, Commercial	200	Gross
Mercantile	30	Gross
Mercantile (Storage, Stock, Shipping Areas)	300	Gross
Not Occupied, Circulation	0	Gross
Per section 1004.2 'Increased Occupant Load'	9	Net
Stages & Platforms	15	Net
Storage areas, Equipment Rooms	300	Gross

ROOM #	ROOM NAME	FUNCTION (PER 1004.1.2)	AREA	SF/PERSON	OCCUPANTS
100	RETAIL	Mercantile	743 SF	30	25
			743 SF		25

1005: MEANS OF EGRESS SIZING:

BUILDING ELEMENT	OCCUPANT LOAD	REQUIRED WIDTH	PROPOSED WIDTH
DOORS (2" x OCC.)	25	5'	174"

CHAPTER 11 - ACCESSIBILITY

REFER TO ACCESSIBILITY GUIDELINES

CHAPTER 29 - PLUMBING SYSTEMS

Existing plumbing systems are not impacted by the project scope.

DEFERRED DRAWING SUBMITTALS

Deferred drawing submittals are not required within the scope of the project.

SPECIAL INSPECTIONS AND TESTING

Special inspections are not required within the scope of the project.

ASBESTOS DISCLAIMER

The Architect hereby states, and the Owner acknowledges, that the Architect has no professional liability (errors and omissions) or other insurance, and is unable to reasonably obtain such insurance, for claims arising out of the performance of or failure to perform professional services, including but not limited to the preparation of reports, designs, drawings and specifications, related to the investigation, detection, abatement, replacement or removal of products, materials, or processes containing asbestos.

Accordingly, the Owner hereby agrees to bring no claim for negligence, breach of contract, indemnity or otherwise against the Architect, his principals, employees, agents, and consultants if such claim in any way would involve the Architect's services for the investigation of or remedial work related to asbestos in the project.

The Owner further agrees to defend, indemnify and hold the Architect and his principals, employees, agents, and consultants harmless from any such asbestos related claims that may be brought by third parties as a result of the services provided by the Architect pursuant to this agreement.

COMMON ABBREVIATIONS

Abv	Above	Jan	Janitor
Acoust	Acoustic(al)	JT	Joint
Adj	Adjustable		
AFF	Above finish floor	KO	Knock-out
Alum	Aluminum	KP	Kick plate
B/C	Bottom of curb	Lab	Laboratory
BD	Booard	Lam	Laminate
Bkg	Blocking	Lav	Lavatory
		Lkr	Locker
Cab	Cabinet	Lpc	Laminated plastic covered
Cpt	Carpet	Lgt	Light
Cem	Cement	LP	Low Point
CG	Corner guard		
CJ	Conit joint	Max	Maximum
CL	Centerline	MDO	Medium density overlay
Clg	Ceiling	Mech	Mechanical
Clr	Clear	Mfr	Manufacturer
Cmu	Concrete masonry unit	Min	Minimum
Col	Column	Misc	Miscellaneous
Const	Construction	Mldg	Moulding
Cont	Continuous	Mrgwb	Moisture resistant GWB
Cr	Center		
		N	North
Dbl	Double	N/A	Not applicable
Demo	Demolish/ Demolition	NIC	Not in contract
Dept	Department	No	Number
Dia	Diameter	Nom	Nominal
Diag	Diagonal	NRC	Noise reduction Coefficient
Dim	Dimension	NTS	Not to Scale
Dsp	Dispenser		
DN	Down	O/C	On center
Dwg	Drawing	OD	Outside diameter
EA	Each	Pwld	Plywood
EL	Elevation		
Elec	Electric(al)	R	Radius/ Riser
EQ	Equal	Ref	Refer/ Reference
Equip	Equipment	Reinf	Reinforced
Exist	Existing	Rm	Room
Ext	Exterior	RO	Rough Opening
FD	Floor drain	S	South
Fin	Finish	Sched	Schedule(d)
FL	Floor	Secl	Section
Fluor	Fluorescent	Sim	Similar
FT	Foot/ Feet	SF	Square Foot/ Feet
FRT	Fire resistant treated	Spec(s)	Specification(s)
		SS	Stainless steel
		Std	Standard
		Sym	Symmetrical
GA	Gauge		
Galv	Galvanized	T&G	Tongue and groove
GB	Grab Bars	Temp	Tempered/ Temporary
GL	Glass, Glazed	Typ	Typical
GR	Grade	UNO	Unless noted otherwise
GWB	Gypsum wall board		
Gyp	Gypsum	VCT	Vinyl composition tile
		Vert	Vertical
HB	Hose Bibb	VIF	Verify in field
HC	Handicapped/ Hollow core	VWC	Vinyl wall covering
Hdwd	Hardwood		
Hdwr	Hardware	W	West
HM	Hollow metal	W/	With
Horiz	Horizontal	W/O	Without
HR	Hour/ Handrail		
Hgt	Height	YD	Yard, Yard drain
HP	High point		
ID	Inside diameter		
Insul	Insulation	&	And
Int	Interior	@	At
		#	Pound(s) or Number

SUPPLY/INSTALLATION

All items contained within these drawings are assumed to be supplied and installed by the General Contractor unless noted otherwise. It is the responsibility of the GC to coordinate delivery and install as applicable within the scope of work.

GENERAL CONSTRUCTION NOTES

- All work will comply with any and all fire and safety codes, or with any federal, state, county or municipal codes having jurisdiction. All applicable requirements in these regulations will apply to the work shown herein, whether specifically indicated as such or not. Conflicts between work set forth herein and any codes, laws or regulations shall be brought to the attention of the Architect prior to proceeding with any work.
- Any reference made in these documents to the "Contractor" shall apply equally to the general Contractor or construction manager, and any Subcontractors or vendors to the Contractor. Similarly, any reference made to a "Subcontractor" or "Vendor" shall be interpreted as meaning the General Contractor or Construction Manager, and does not imply the Architect's involvement in the Contractor's means or methods of executing the work.
- The organization or arrangement of these drawings and/or accompanying specifications is for convenience only, and shall not relieve the Contractor for responsibility of delivering a complete functioning project, of supervising and coordinating the work of all trades, or of dividing the work among his Subcontractors or in establishing the extent of work to be performed by any trade.
- All work shall be in strict conformance with the requirements of these documents and the requirements of the Owner (especially regarding scheduling, areas of work and temporary controls). It is the Contractor's responsibility to acquaint himself with these requirements. Contractor is to investigate any special requirements and conditions of the site. Contractor's bid will be assumed to include the cost of fulfilling these requirements.
- Design and selection of supports, braces, anchors, attachments and related fasteners, unless shown on the drawings or in the specifications, are the responsibility of the installing contractor utilizing industry standard materials and methods suitable to the condition.
- The Owner is responsible to pay for, and the Contractor is responsible to obtain, all permits required by federal, state, county or municipal authorities; the Contractor shall include in the contract the cost of such permits.
- The Contractor is to arrange for elevator or other hoisting facilities for materials and equipment. Arrangements shall be made through the building management. Costs for delivery, storage, and/or handling of materials shall be included in the bid. The Contractor shall become familiar with and work within the Owners or building management's guidelines and procedures for security, registration, delivery, allowable working times, access to adjoining tenants, noise, etc.; costs of complying with these requirements will not be justification for additional charges.
- The Contractor shall verify building opening sizes and clearances (doors, elevators, docks, corridors, etc.) to allow for the delivery of all required materials and project components.
- The Contractor will post material safety data (MSD) sheets on the jobsite for any hazardous materials in compliance with federal, state and local authorities.
- Install manufactured materials and equipment in strict accordance with the manufacturer's written instructions and guidelines. The Contractor is to inform the Architect of items specified which may not be readily available or which have long lead times.
- The Contractor shall provide barriers, temporary partitions or other measures for the protection of occupants, workers or occupied or finished areas and surfaces. This is to include noise barriers, vapor barriers, dust barriers or other protection as requested by the Owner. An allowance for these materials shall be included in the contract and costs for the materials above the allowance shall be approved by the Owner.
- The Contractor is to remove all debris and leave all areas broom clean at the end of each work day, and protect any portion of existing work to remain or work previously installed.
- The Contractor shall investigate ceiling plenums and report extent of interference of overhead construction (ie duct work, pipes, plumbing, etc.), to Architect prior to start of work so as to accommodate the specified ceiling, lighting and mechanical systems. If requested by the Architect, the Contractor shall prepare a coordination drawing indicating the interface of all trades.
- The Contractor will perform all work for the contract sum without adjustment in the event of labor disputes and/or work stoppages.
- Items specified in these drawings are for reference, and are not intended to be proprietary. The Contractor may submit a written request along with his bid for Architect's approval of equal substitutions.
- There will be no substitutions for specified products, equipment or systems other than those approved prior to signing the contract, unless the substitution can be shown to be of significant benefit to the Owner and place no additional expense on the Architect to process. The Owner and Architect must approve all substitutions.
- Level of drywall finishes (as specified in ASTM C840):
 - Level 1 - areas above opaque ceiling
 - Level 2 - as substrate for ceramic tile
 - Level 4 - all areas not indicated to receive levels 1,2 or 5. All wall areas above open cell ceilings.
 - Level 5 - only where specifically indicated on plans.

NOTICE TO BIDDERS

Drawings contained within are a visual representation of the Scope of Work. It is the responsibility of the Bidding Contractors to perform a site visit to familiarize themselves with the unique characteristics of the project. Contact the Construction Manager or Owner to arrange a site visit.

The Contractor is to provide written notification to the Construction Manager or Owner of any discrepancies discovered between site conditions and these Documents. Submission of a bid is confirmation that the existing conditions have been accepted and fully accounted for in the costs provided.

Ad Astra Design, LLC (Architect) does not handle the bidding process. Direct all bidding related questions to the Construction Manager or Owner.

CONSTRUCTION SUBMITTALS

- Provide all submittals in advance of installation for proper review by Architect & Owner.
- Allow at least 10 working days for Architect review time.
- The Contractor shall review and approve all submittals prior to their submission to the Architect. Any submittal not signed, dated and stamped approved by the Contractor will be rejected.
- The Contractor shall submit three samples of all finish materials, of a size appropriate to view the material being submitted, to the Architect for review prior to initiating installation of the material. Email submissions are acceptable & preferred.
- The Contractor is to submit product data sheets for any catalog items including any and all building standard items called for on the drawings.
- Prior to fabrication** - The Contractor shall submit shop drawings for all off-site fabricated items to the Architect for review. Any work fabricated prior to review not complying with the Contract Documents will be rejected.
- Substitutions to items specified in these Contract Documents should be made only prior to bidding. If the Owner authorizes the Architect to review a substitution after bidding, the item must be submitted separately and clearly identified as a substitution and **not** included within another submission or it will be rejected.



PROJECT STATUS

MINOR PROJECT REVIEW

CURRENT ISSUE DATE

FEBRUARY 16, 2024

PROJECT NO.

23005

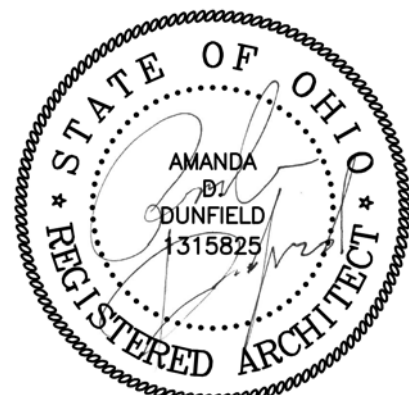

Amanda Dunfield, License # 1315825
Expiration Date: December 31, 2025

REVISIONS

#	Description	Date

PROJECT INFORMATION

J.Hilburn

6560 Longshore Street
Dublin, OH 43017

SHEET NAME

General Notes
& Code Info.

SHEET NUMBER

G002

ASSEMBLY AREAS

Figure 802.3 Width of wheelchair space in assembly areas

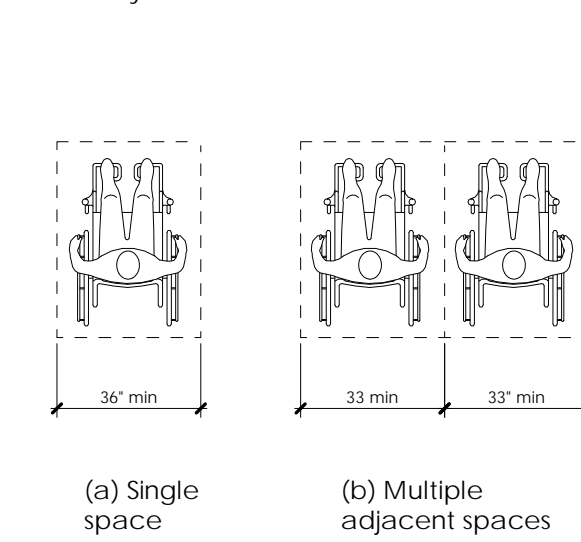
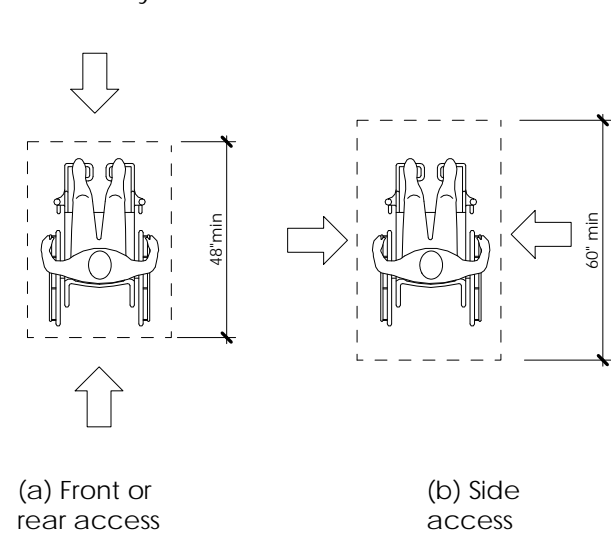

Figure 802.4 Depth of wheelchair space in assembly areas



CLEAR FLOOR SPACE

Figure 305.3 Size of clear floor space

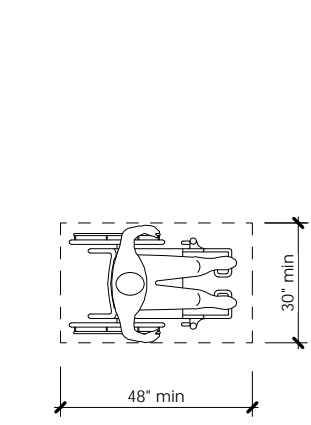
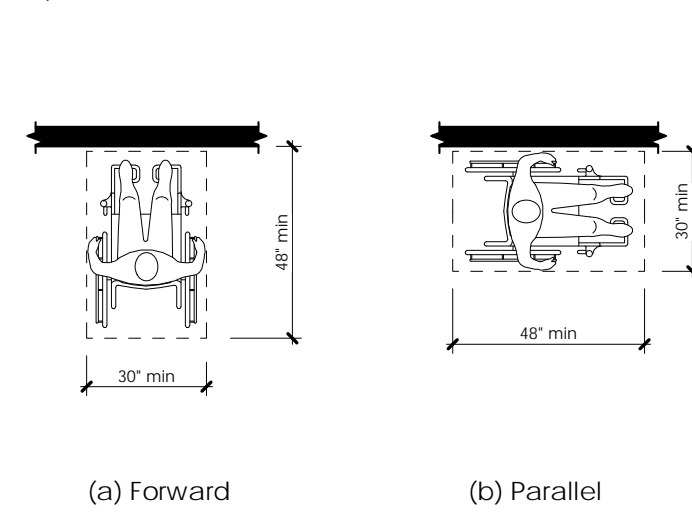
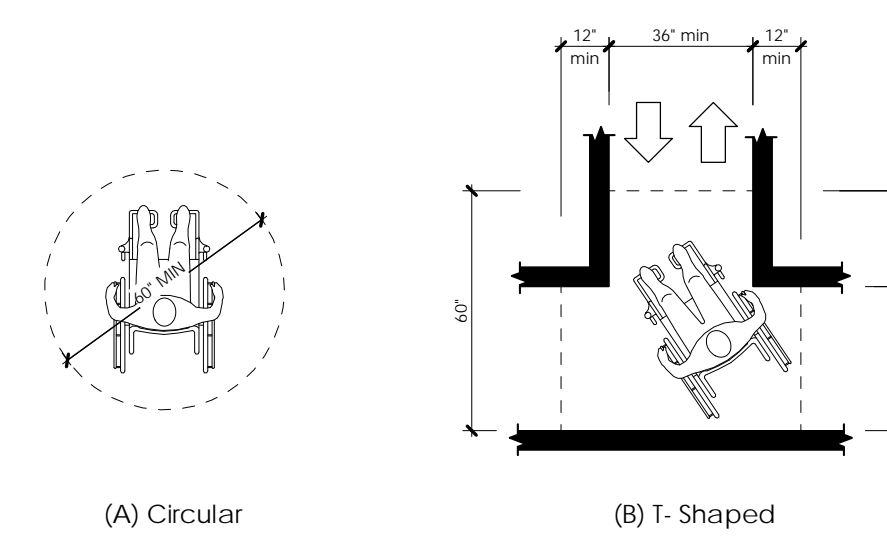

Figure 305.5 Position of Clear floor space



TURNING SPACE

Figure 304.3 - Size of turning space



CHANGES IN LEVEL

Figure 302.2 Carpet Pile Height

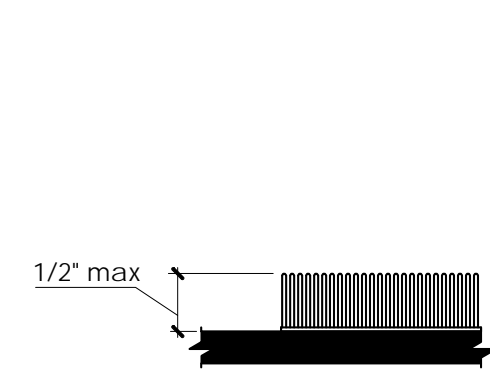

Figure 302.3 Elongated Openings in Floor or Ground Surfaces

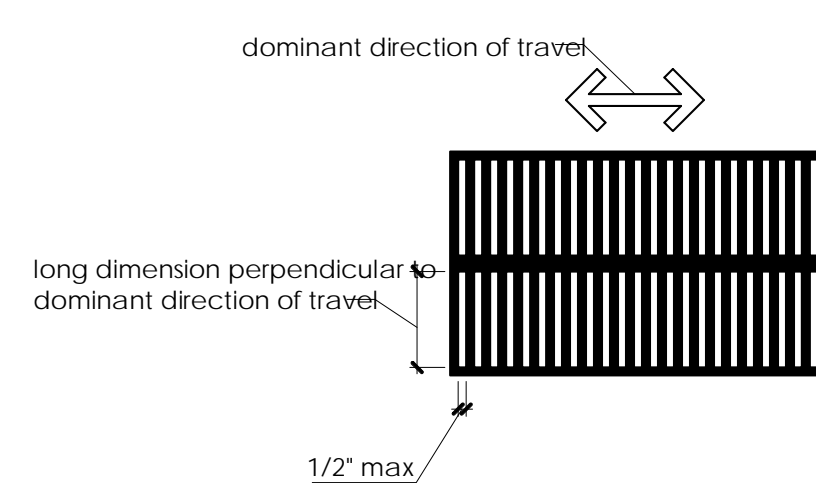

Figure 303.2 Vertical Changes in Level

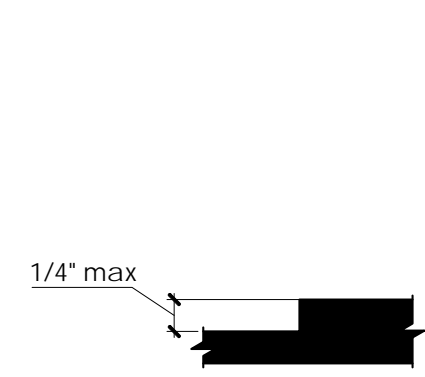
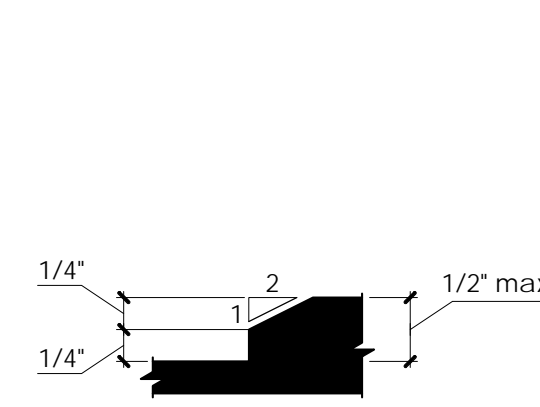

Figure 303.3 Beveled Changes in Level



PROTRUDING OBJECTS

Figure 307.2 - Limits of protruding objects

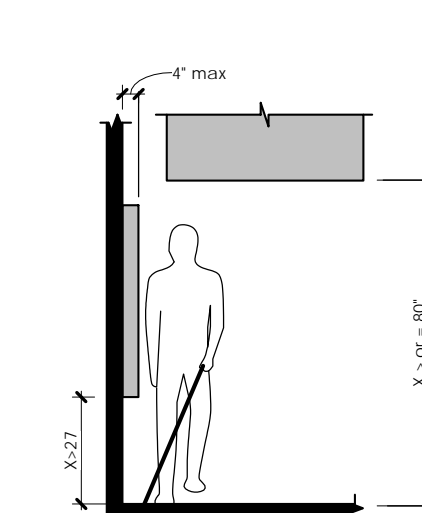
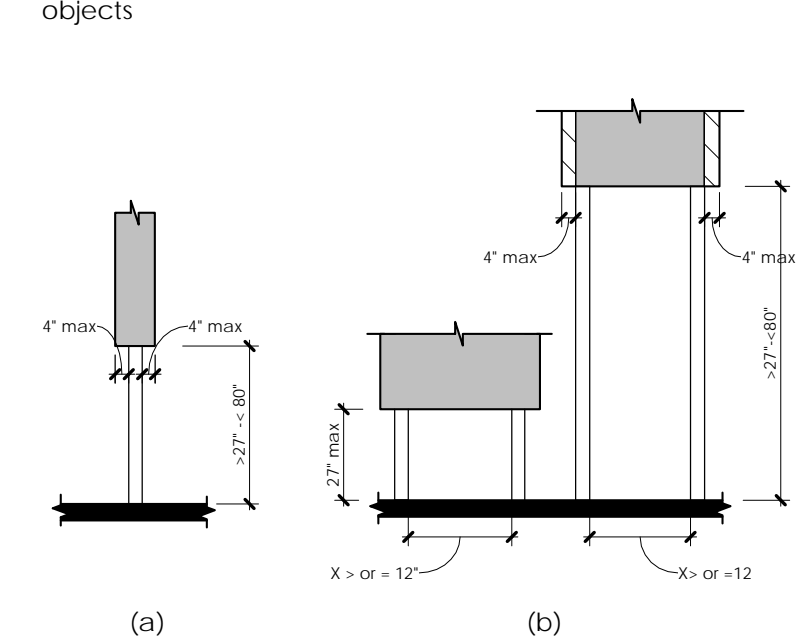
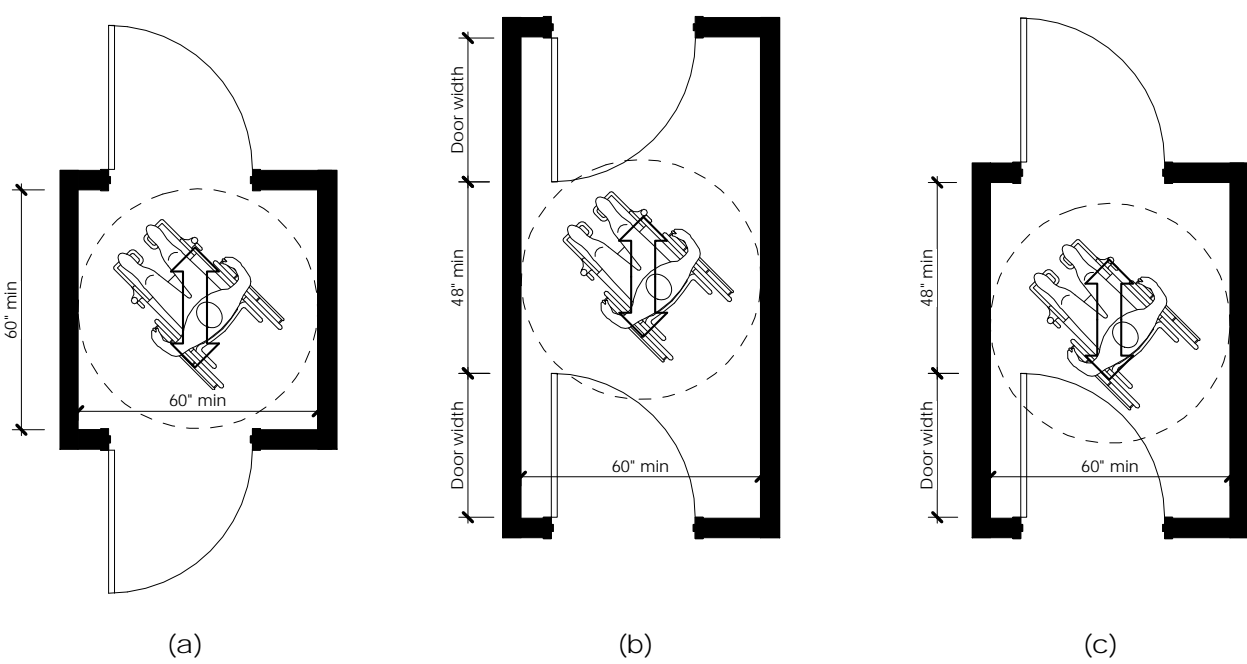

Figure 307.3 Post-mounted protruding objects



ACCESSIBLE DOORS IN A SERIES

Figure 404.2.5 Two doors in series



REACH RANGES

Figure 308.2.1 Unobstructed forward reach

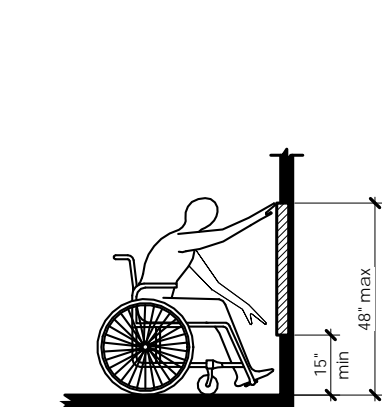

Figure 308.2.2 Unobstructed high forward reach

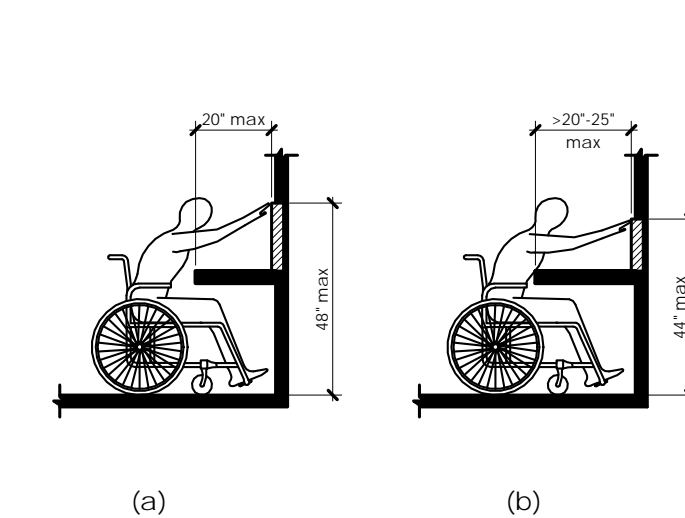

Figure 308.3.1 Unobstructed side reach

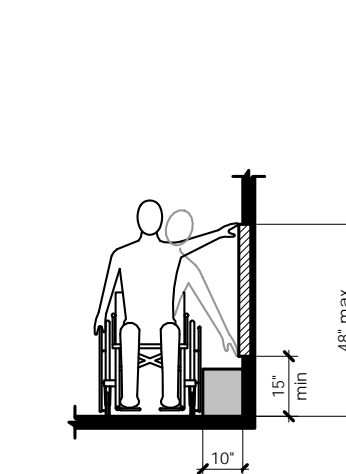
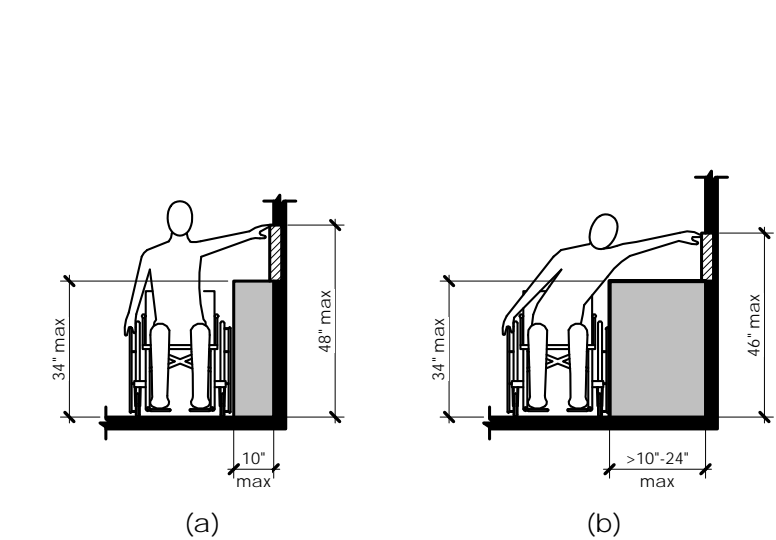

Figure 308.3.2 Unobstructed high side reach



SIGNS

Figure 703.3.10 Height of raised characters above floor

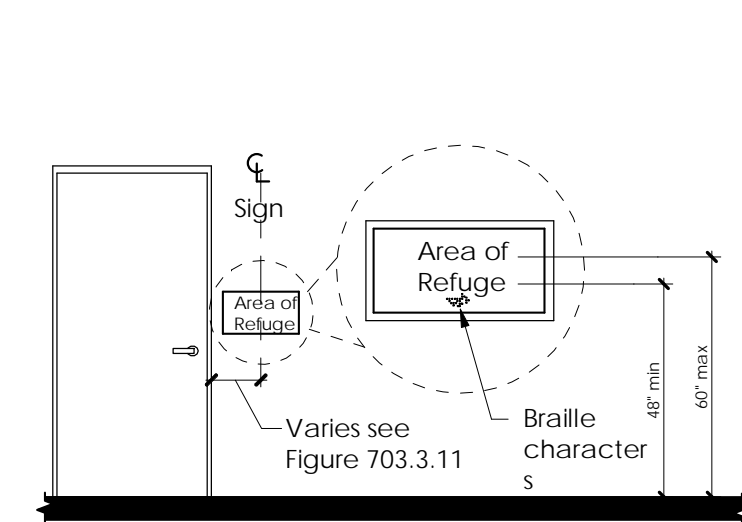
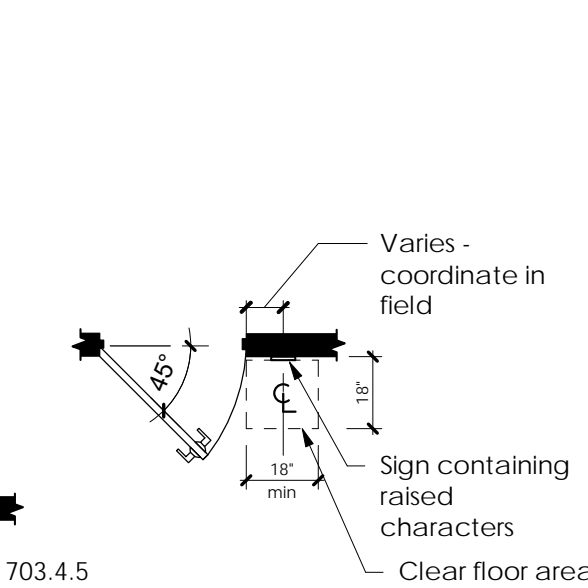

Figure 703.3.11 Location of Tactile signs at doors



Note - For braille character mounting height see section 703.4.5

WALKING SURFACES

Figure 403.5 Clear width of an accessible route

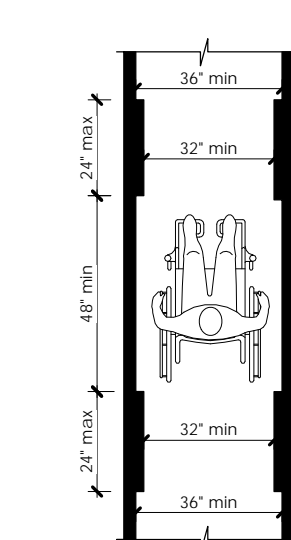
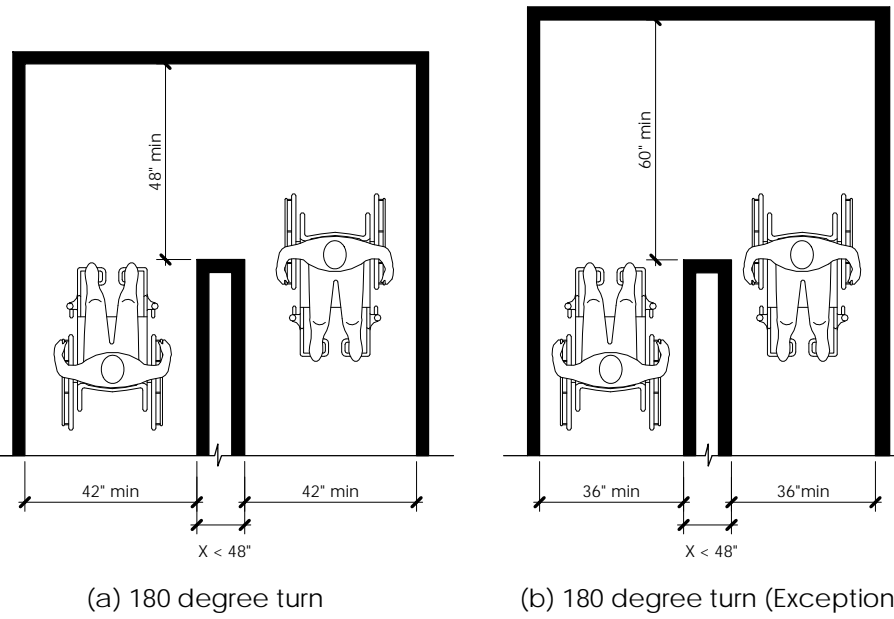

Figure 403.4.1 Clear width at 180 degree turn



KNEE & TOE CLEARANCES

Figure 306.2 Toe clearance

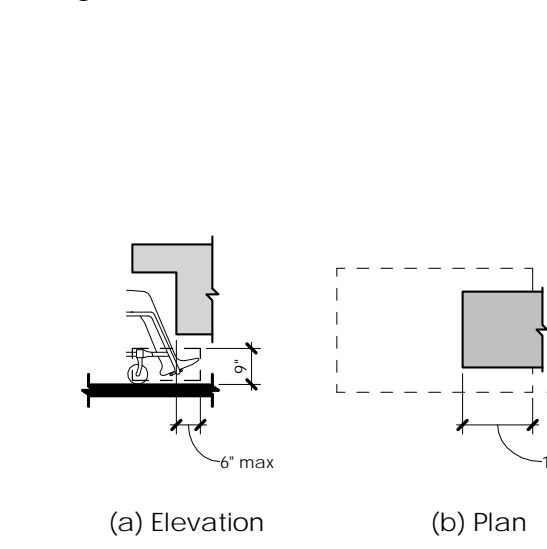
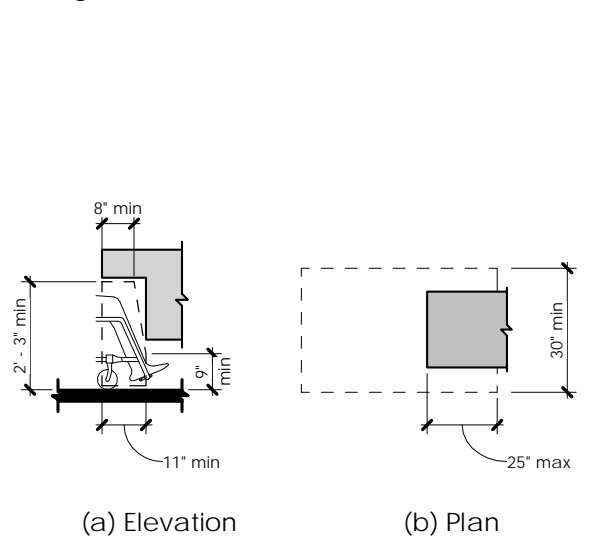

Figure 306.3 Knee Clearance



SIGNS - RAISED CHARACTERS

Provide (1) sign per toilet room and (1) sign per exit passageway/ discharge complying with the referenced standard or the local authority having jurisdiction. Black plastic (field) background w/ white raised uppercase letters, braille and emblems. Refer to Life Safety Plan for keynoted locations.

Note - pictograms and lettering must be raised 1/32" min. Sign to have raised and braille characters and pictogram symbols of accessibility. Mount 5'0" to centerline A.F.F. Refer to sections 703.2 through 703.6 for additional information.

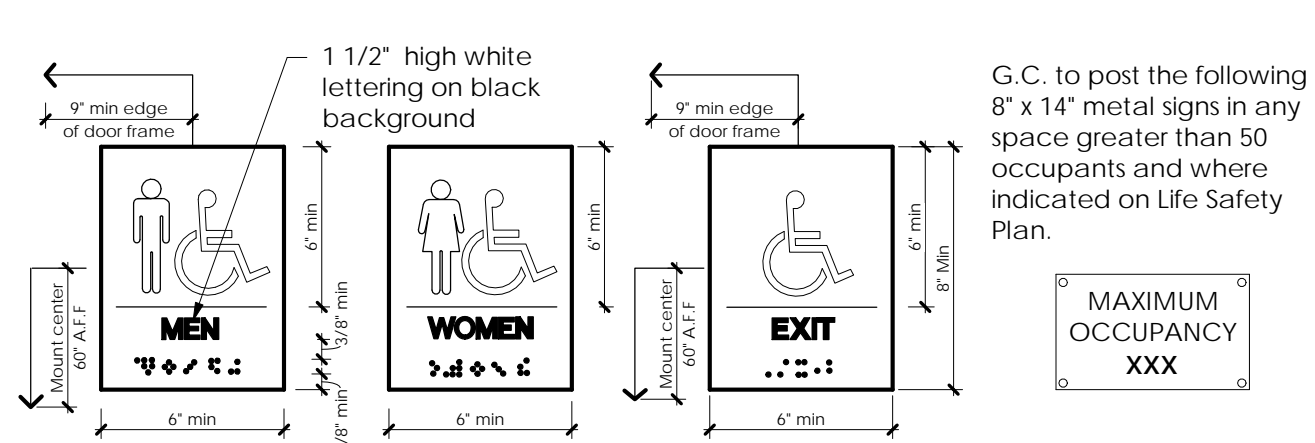

HANDRAILS

Figure 505.4 Handrail height

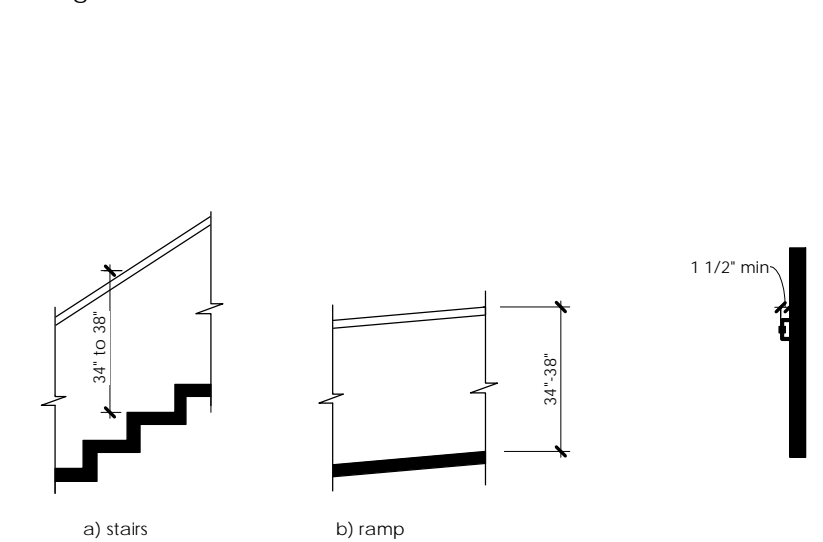

Figure 505.5 Handrail clearance

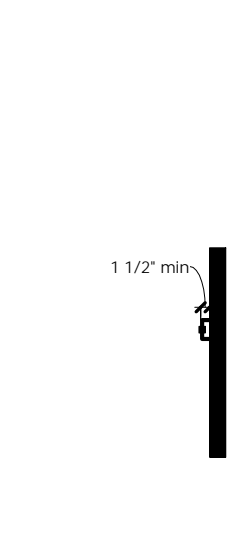

Figure 505.10.1 Top and bottom handrail extensions at ramps

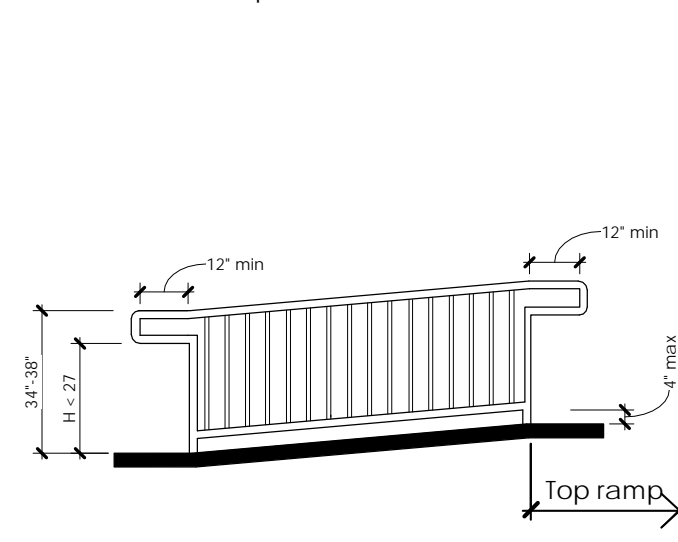

Figure 505.10.2 Top handrail extensions at stairs

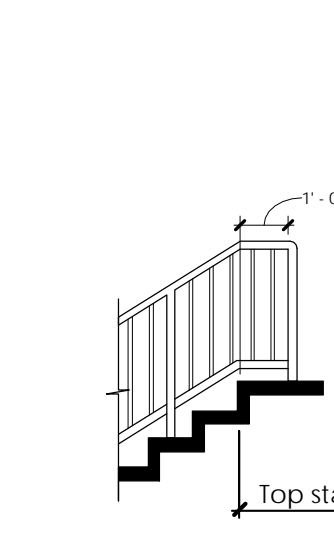
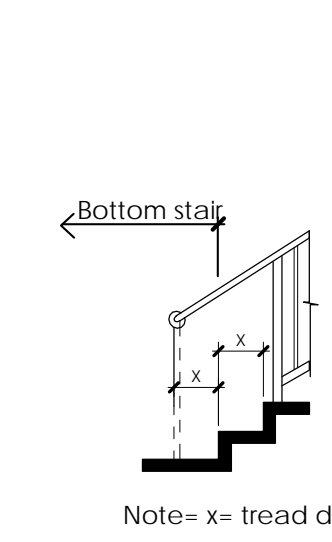
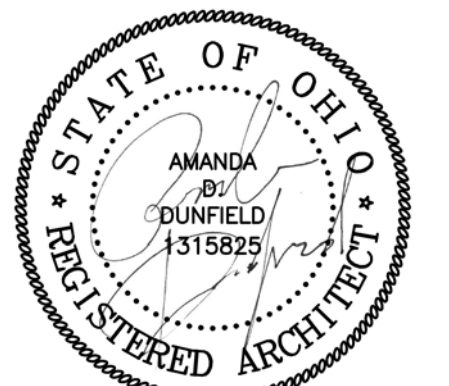

Figure 505.10.3 Bottom handrail extensions at stairs



ACCESSIBILITY GENERAL NOTES

- All indicated dimensions are clear/finish values.
- Referenced standard as indicated on title sheet.
- The "General Accessibility Notes" and "Figures" on this sheet are provided as a general reference to illustrate common conditions addressed within the referenced standard. Some figures have been modified from those published in the standard to provide greater clarity. General contractor should reference the complete publication for any clarifications or questions.
- Protruding objects**
Protruding objects on circulation paths shall comply with section 307.
- Operable Parts**
Operable parts on accessible elements, accessible routes, and in accessible rooms and spaces shall comply sections 309 and 404.2.6.
- Accessible routes**
Accessible routes shall comply with section 304 and chapter 4.
- Parking spaces**
Where parking spaces are provided, parking spaces shall be provided in accordance with sections 406 and 502.
- Passenger loading zones and bus stops**
Where provided, passenger loading zones shall comply with sections 503 and 805.
- Stairways**
Where provided, interior and exterior stairs that are part of a means of egress shall comply with sections 504 and 505.
- Drinking fountains**
Where drinking fountains are provided at an exterior site, on a floor, or within a secure area, they shall be provided in accordance with sections 305, 306, and 602.
- Kitchens, kitchenettes, and sinks**
Where provided, kitchens, kitchenettes, and sinks shall comply with sections 308, 606, and 804.
- Toilet facilities and plumbing elements**
Where toilet facilities are provided, they shall comply with section 305 and chapter 6.
- Signs**
Signs shall be provided in accordance with section 703.
- Assembly areas**
Assembly areas shall provide wheelchair spaces, companion seats, and designated aisle seats complying with sections 802 and 902.
- Dressing, fitting, and locker rooms**
Where dressing, fitting, and locker rooms are provided, at least 5%, but no fewer than one of each type of use is each cluster provided shall comply with sections 803 and 903.
- Storage**
Where storage is provided in accessible spaces, at least one of each type shall comply with sections 305 and 905.
- Dining surfaces and work surfaces**
Where dining surfaces are provided for the consumption of food or drink, at least 5 percent of the seating spaces and standing spaces at the dining surfaces shall comply with sections 305 and 902. In addition, where work surfaces are provided for use by other than employees, at least 5% shall comply with sections 305 and 902.
- Sales and service**
Where provided, check-out aisles, sales counters, service counters, food service lines, queues, and waiting lines shall comply with sections 305, 403, and 904.



Amanda Dunfield, License # 1315825
 Expiration Date: December 31, 2025

REVISIONS

#	Description	Date

PROJECT INFORMATION

J. Hilburn

6560 Longshore Street
 Dublin, OH 43017

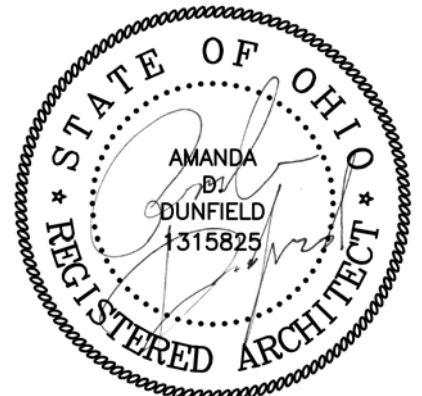

Amanda Dunfield, License # 1315825
 Expiration Date: December 31, 2025

#	Description	Date

PROJECT INFORMATION

J. Hilburn

6560 Longshore Street
 Dublin, OH 43017

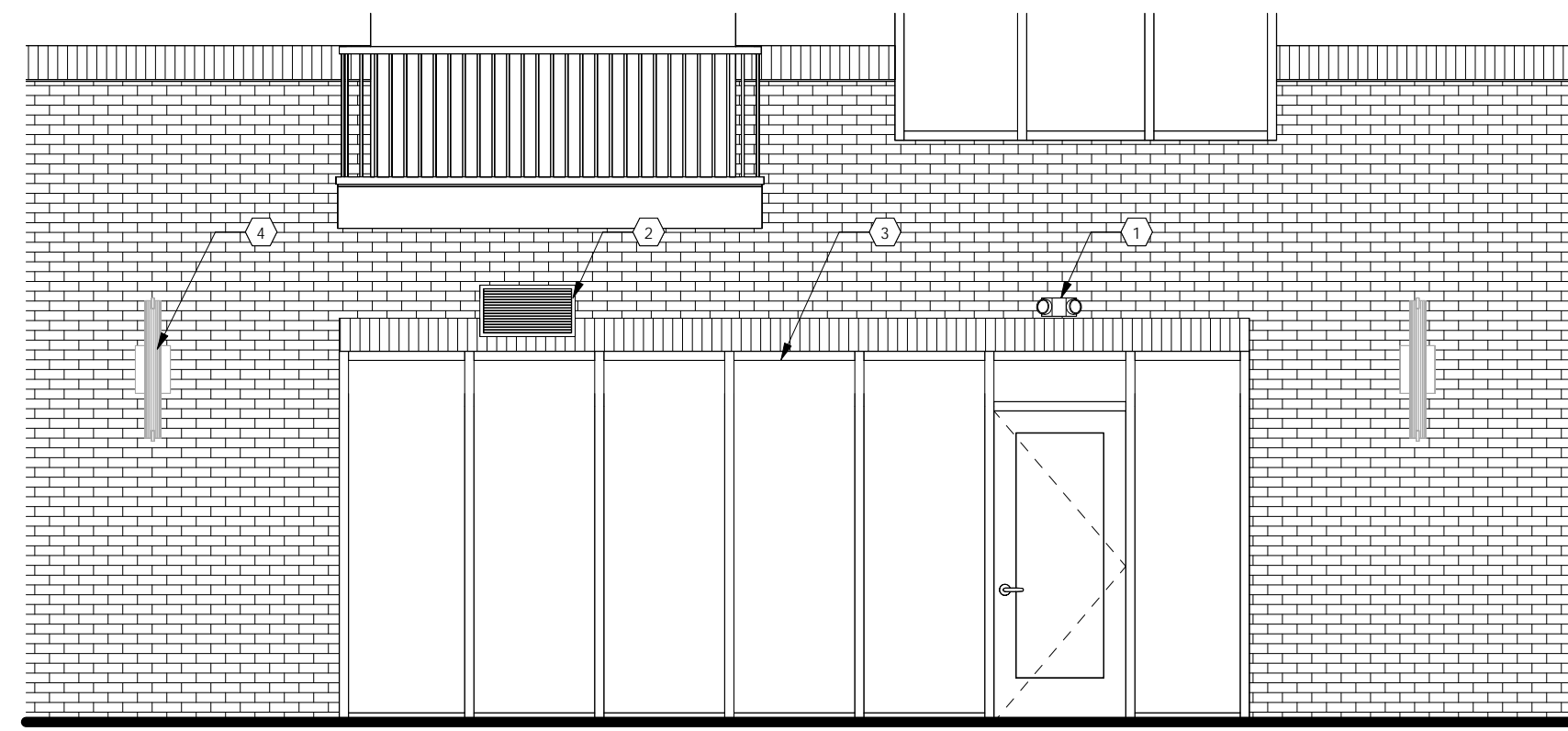

1 Demolition Elevation
 Scale: 1/4" = 1'-0"

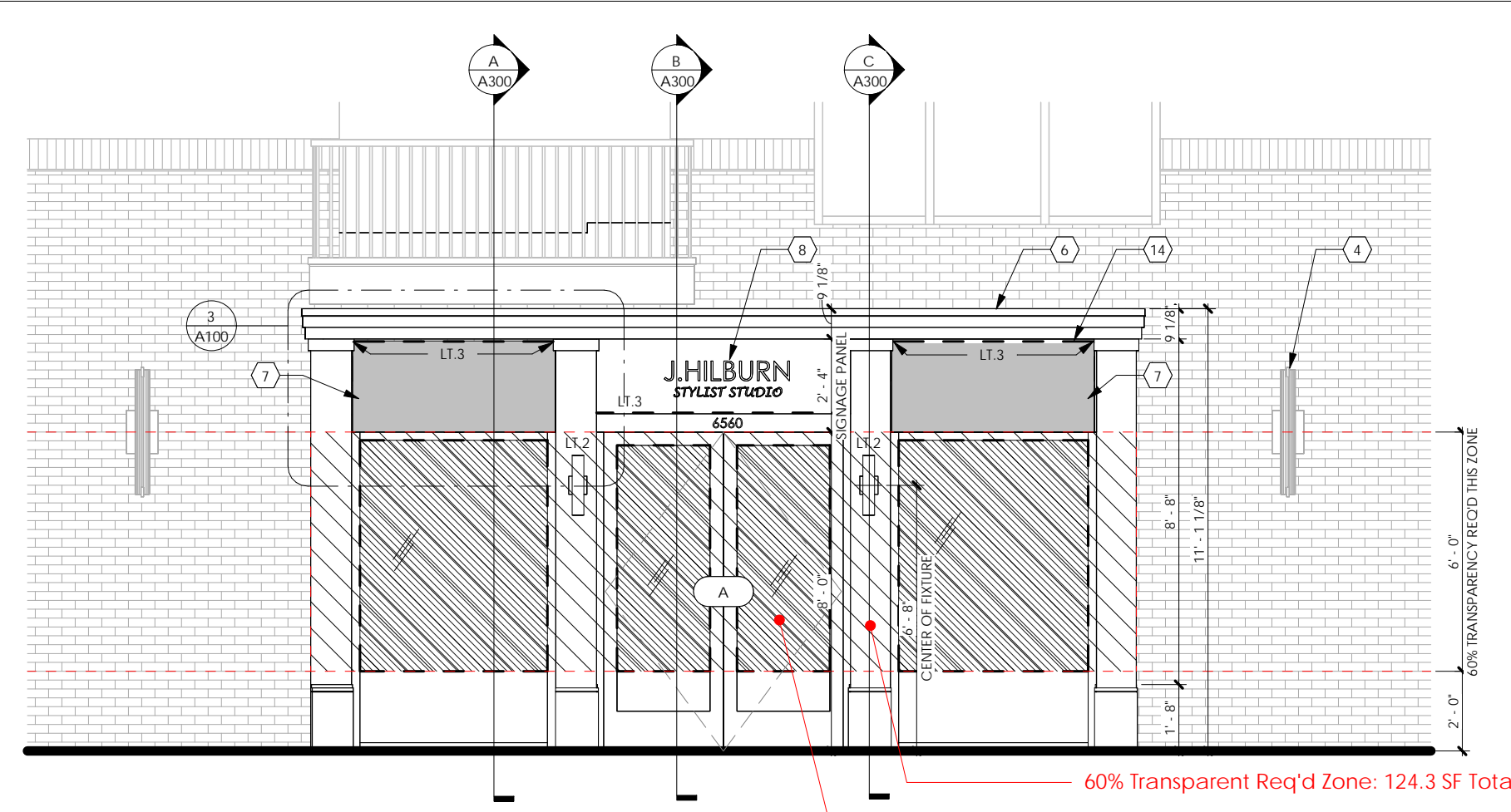

2 New Work Elevation
 Scale: 1/4" = 1'-0"

60% Transparent Req'd Zone: 124.3 SF Total
 Actual Transparent Area: 81.1 SF
 New Storefront Transparent Area: 65.2%

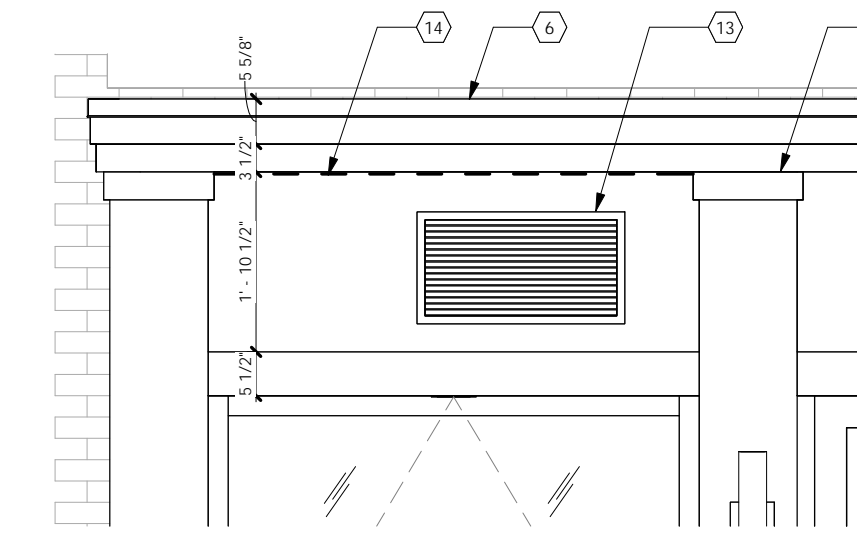

Note: Awning hidden for clarity

3 Louver Detail
 Scale: 1/2" = 1'-0"

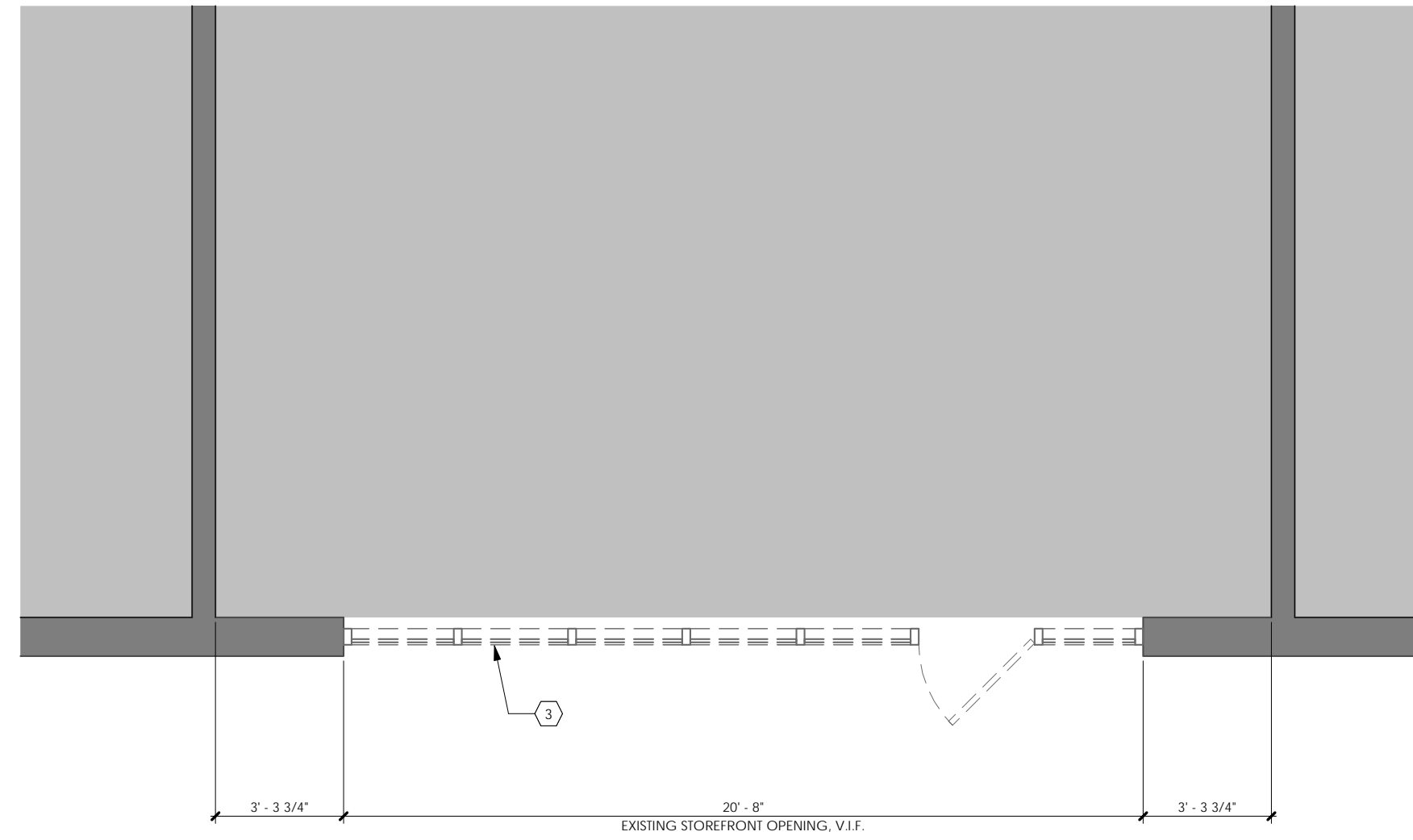

z Demolition Plan
 Scale: 1/4" = 1'-0"

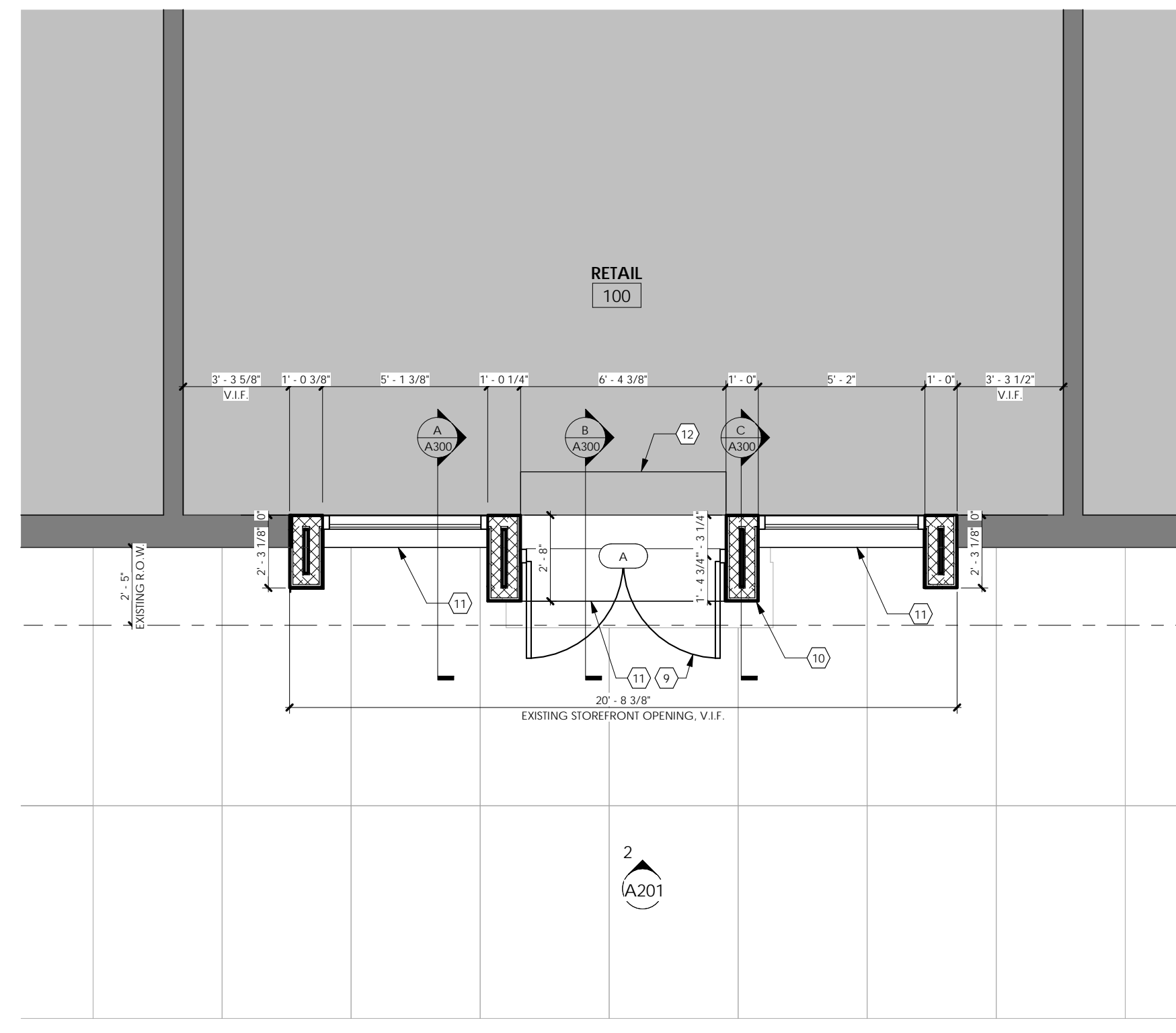

z Architectural Plan
 Scale: 1/4" = 1'-0"



z Reflected Ceiling Plan - 9'-0" AFF
 Scale: 1/4" = 1'-0"

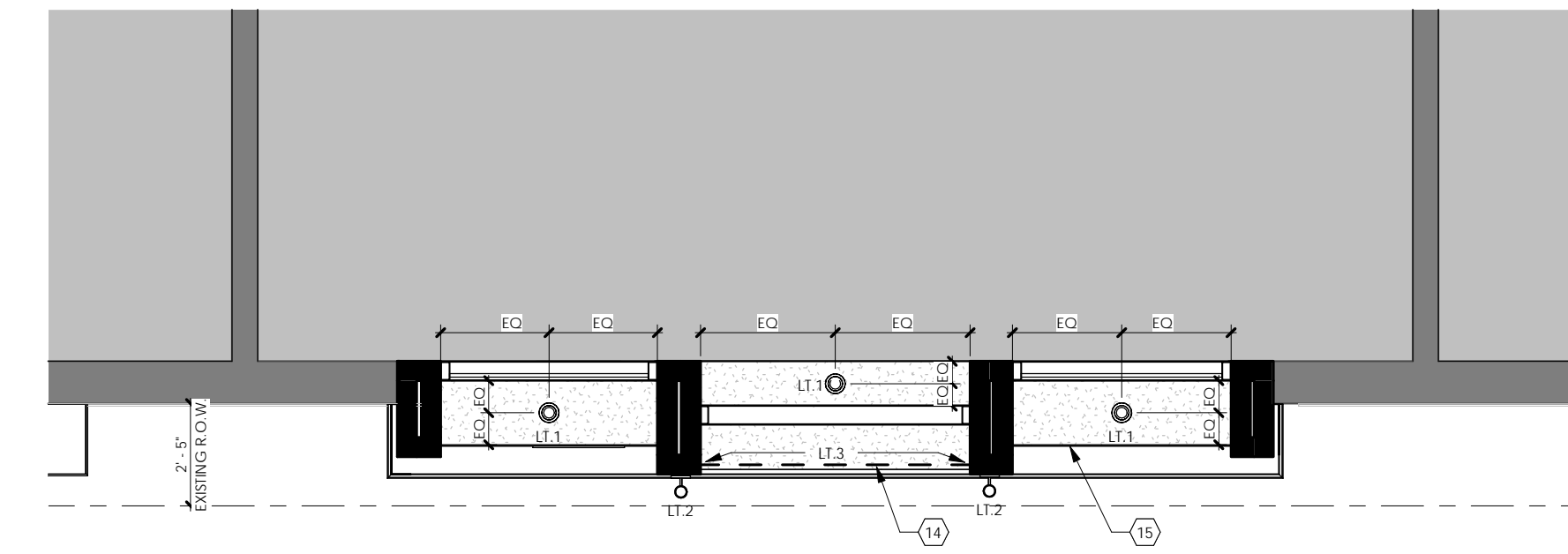

z Reflected Ceiling Plan 7'-0" AFF
 Scale: 1/4" = 1'-0"

GENERAL NOTES

- A. Do not scale drawings. If dimensions are in question, the contractor shall be responsible for seeking clarification from Architect prior to construction.
- B. All dimensions are from finished surface to finished surface, unless noted otherwise.

KEYNOTES

- 1 Existing EM lighting to be removed. Relocate circuit for new EM lighting as required.
- 2 Existing louver to remain. Extend to new location as indicated.
- 3 Existing storefront to be removed. Verify extents in field.
- 4 Existing sconce fixture to remain, typ.
- 5 NOT USED
- 6 Preformed metal coping to match paint finish.
- 7 Awning by others.
- 8 Signage by others.
- 9 New doors as indicated. Refer to door schedule.
- 10 New framing as indicated. Provide painted cement fiber board finish. Refer to sections.
- 11 Replace sidewalk and substrate as required this area. Provide epoxy dowel connection to existing slab.
- 12 Patch/repair interior concrete slab and LVT flooring as required.
- 13 Extend existing louver to new location as indicated.
- 14 Recessed LED tape light fixture at overhang. Refer to details.
- 15 Painted, exterior rated gypsum ceiling, typ.

LEGEND

Indicates existing to remain.

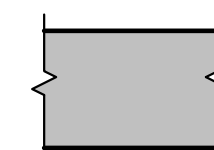

Indicates new construction

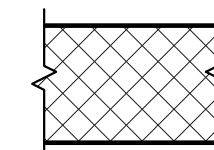

Indicates batt insulation within wall. Batt thickness based on stud size. Provide sound sealant continuous at all joints at interior locations. Refer to specifications sheet for additional information.

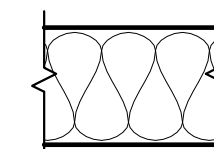

LIGHT FIXTURE SCHEDULE

Type	Description	Manufacturer	Model	Comments
LT.1	Recessed Can	Sistemalux	Nanoled S3321W-19	3000K; Stainless steel finish
LT.2	Up/Down Sconce (Exterior 2)	Alcon Lighting	Alcon 11240-2-BK	3000K; 4" Cylinder LED uplight & downlight
LT.3	LED Tape (Black)	Kelvix	Orex RX Series RX-24K	2400K; Flat aluminum channel mount #RX-CH-IL-2-FL

DOOR SCHEDULE

Door #	Description	Slab Height	Width	Hardware	Comments
A	Jeld-Wen Epic-Custom Collection	8' - 0"	6' - 0"	Omnia OMN-BTB-9031P Pulls: ORB finish typ.	Brickmould Trim; Tricom Black finish



ASTRA STUDIOS

PROJECT STATUS
 MINOR PROJECT REVIEW
 CURRENT ISSUE DATE
 FEBRUARY 16, 2024
 PROJECT NO.
 23005

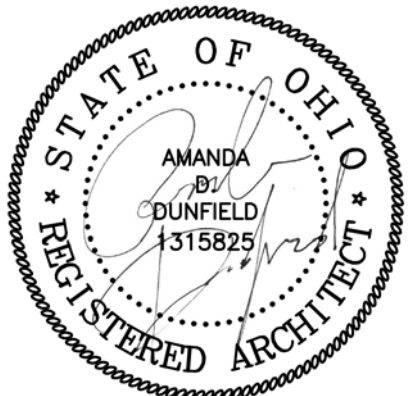

Amanda Dunfield, License # 1315825
 Expiration Date: December 31, 2025

REVISIONS

#	Description	Date

PROJECT INFORMATION

J.Hilburn

6560 Longshore Street
 Dublin, OH 43017

KEY PLAN - SITE LOCATION

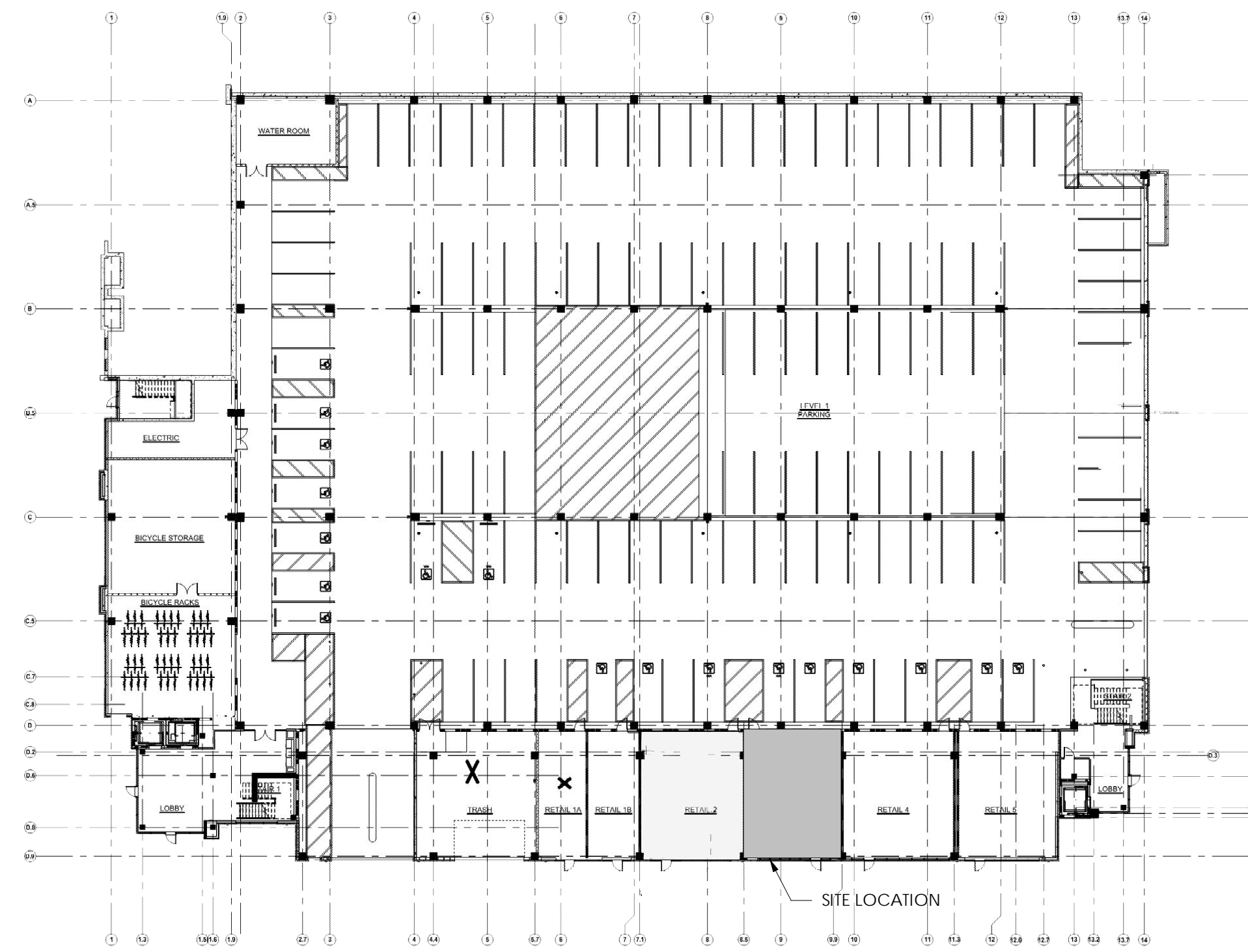

SITE PLAN

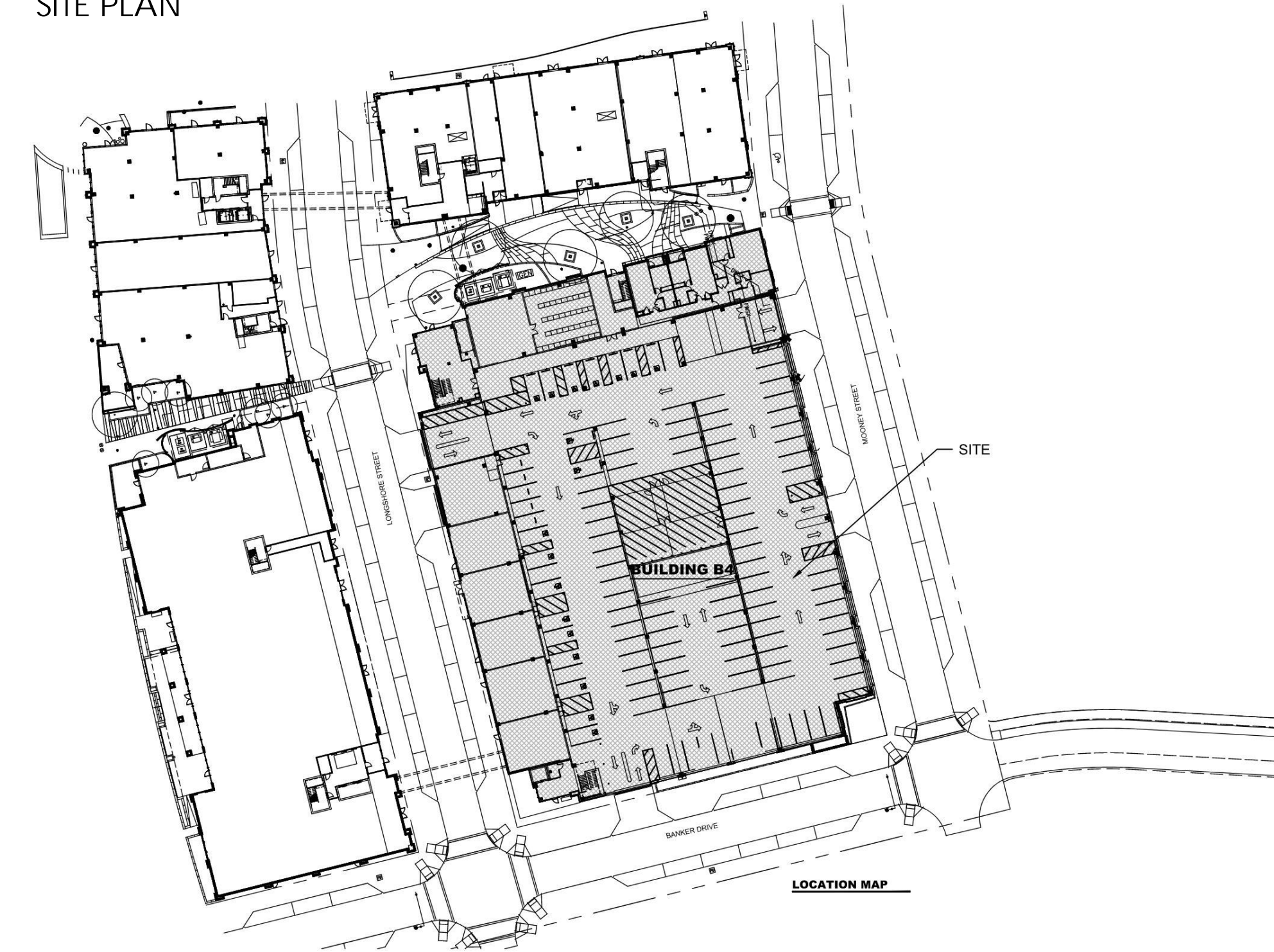

PARKING STRUCTURE CORRIDOR BUILDING



FAÇADE MATERIALS - CORRIDOR BUILDING

OVERALL AREA OF ELEVATION: 17,249 S.F.
 AREA OF WINDOWS/DOORS: 3,080 S.F. - a decrease of 26 S.F.
 NET AREA OF ELEVATION: 14,169 S.F.

MATERIAL	PRIMARY/SECONDARY	AREA (S.F.)	PERCENTAGE	REQUIRED	MET?
BRICK	PRIMARY	7,673 S.F.	54%		
GLASS	PRIMARY	1,986 S.F.	14%		
COMPOSITE METAL PANEL	PRIMARY	809 S.F.	6%		
TOTAL PRIMARY		10,468 S.F.	74%	80%	
FIBER CEMENT	SECONDARY	3,539 S.F.	25%		
MISC ELEMENTS	PERMITTED AS TRIM	162 S.F.	1%		
TOTALSECONDARY		3,701 S.F.	26%	<20%	

FAÇADE MATERIALS - PARKING STRUCTURE

OVERALL AREA OF ELEVATION: 2,997 S.F.

MATERIAL	PRIMARY/SECONDARY	AREA (S.F.)	PERCENTAGE	REQUIRED
BRICK	PRIMARY	747 S.F.	25%	
GLASS	PRIMARY	1,746 S.F.	58%	
COMPOSITE METAL PANEL	PRIMARY	378 S.F.	13%	
TOTAL PRIMARY		2,493 S.F.	96%	80%
MISC ELEMENTS	PERMITTED AS TRIM	126 S.F.	4%	
TOTALSECONDARY		126 S.F.	4%	<20%

STREET FAÇADE

TRANSPARENCY - CORRIDOR BUILDING

STORY AREA	1ST STORY	2ND STORY	3RD STORY	4TH STORY	5TH STORY	6TH STORY
STORY AREA:	1799 S.F.	3,229 S.F.	3,352 S.F.	3,352 S.F.	3,352 S.F.	3,352 S.F.
TRANSPARENCY:	1,051 S.F.	1,017 S.F.	1,110 S.F.	1,110 S.F.	1,110 S.F.	1,110 S.F.
REQUIRED:	60%	30%	30%	30%	30%	30%
PROVIDED:	58%	31%	33%	33%	33%	52%

STREET FAÇADE

TRANSPARENCY - PARKING STRUCTURE

STORY AREA	1ST STORY	2ND STORY	3RD STORY	4TH STORY	5TH STORY	6TH STORY
STORY AREA:	504 S.F.	506 S.F.	506 S.F.	506 S.F.	506 S.F.	570 S.F.
TRANSPARENCY:	196 S.F.	333 S.F.	333 S.F.	333 S.F.	333 S.F.	316 S.F.
REQUIRED:	65%	N/A%	65%	N/A%	N/A%	N/A%
PROVIDED:	39%	66%	66%	66%	66%	55%

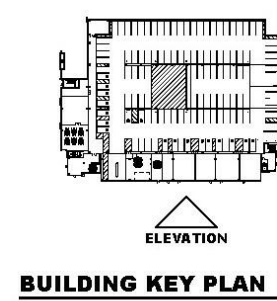

BUILDING KEY PLAN

SHEET NAME

Storefront Calculations

SHEET NUMBER

A201

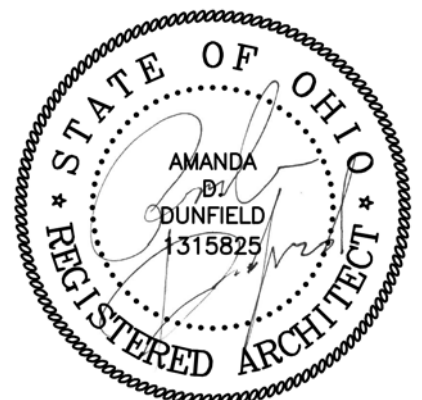

Amanda Dunfield, License # 1315825
Expiration Date: December 31, 2025

REVISIONS

#	Description	Date

PROJECT INFORMATION

J.Hilburn

6560 Longshore Street
Dublin, OH 43017

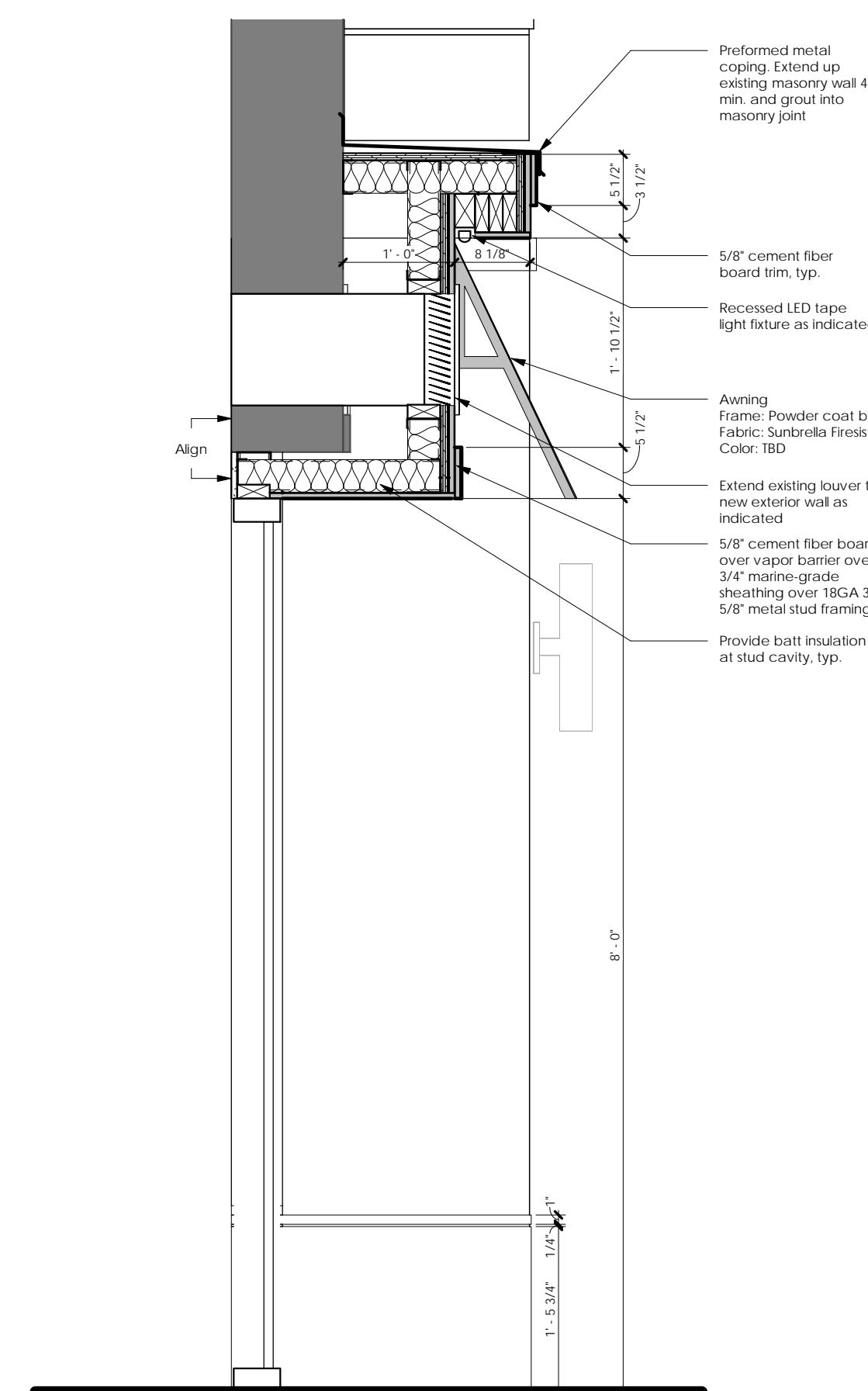

A Section
Scale: 3/4" = 1'-0"

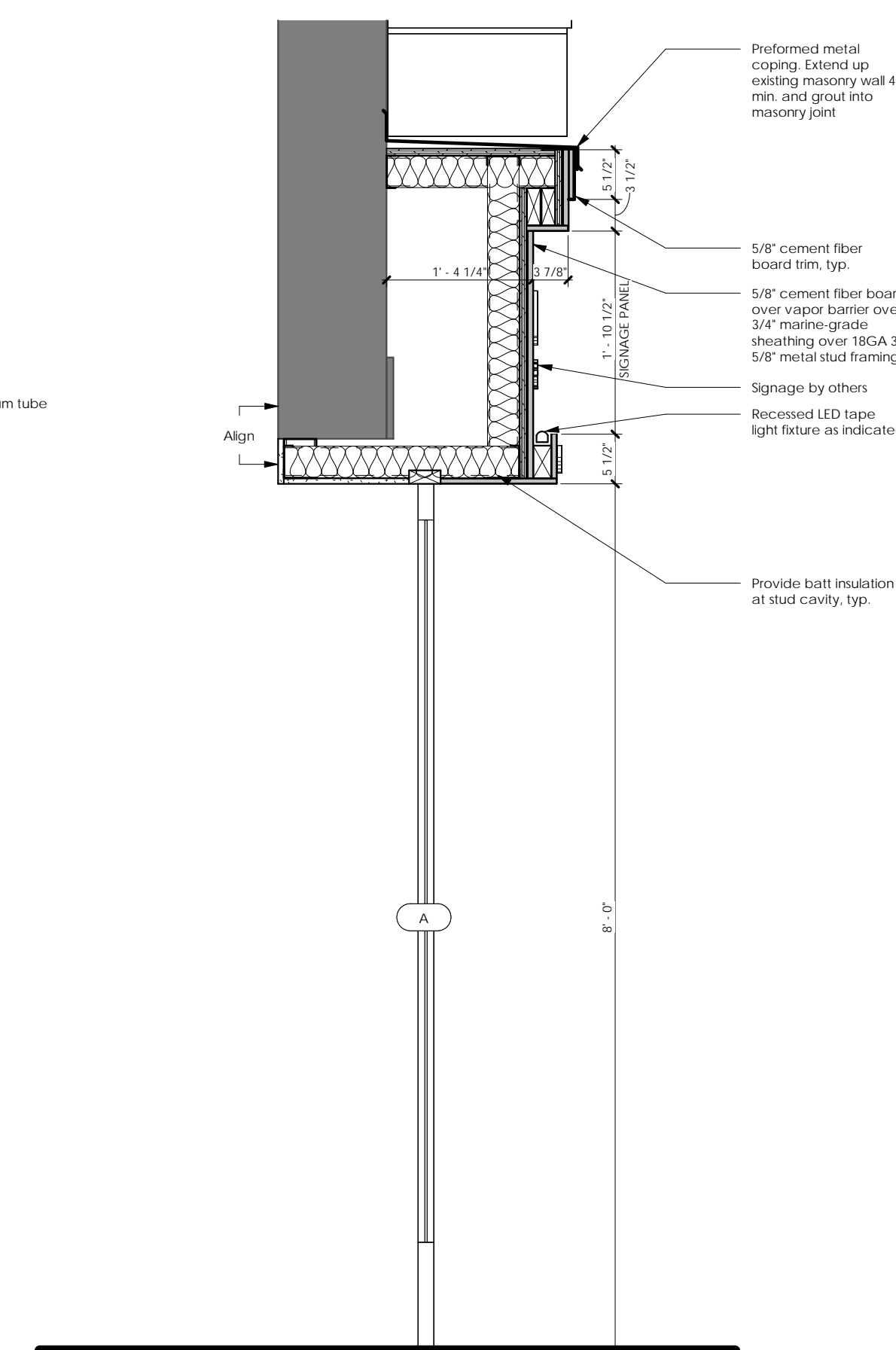

B Section
Scale: 3/4" = 1'-0"

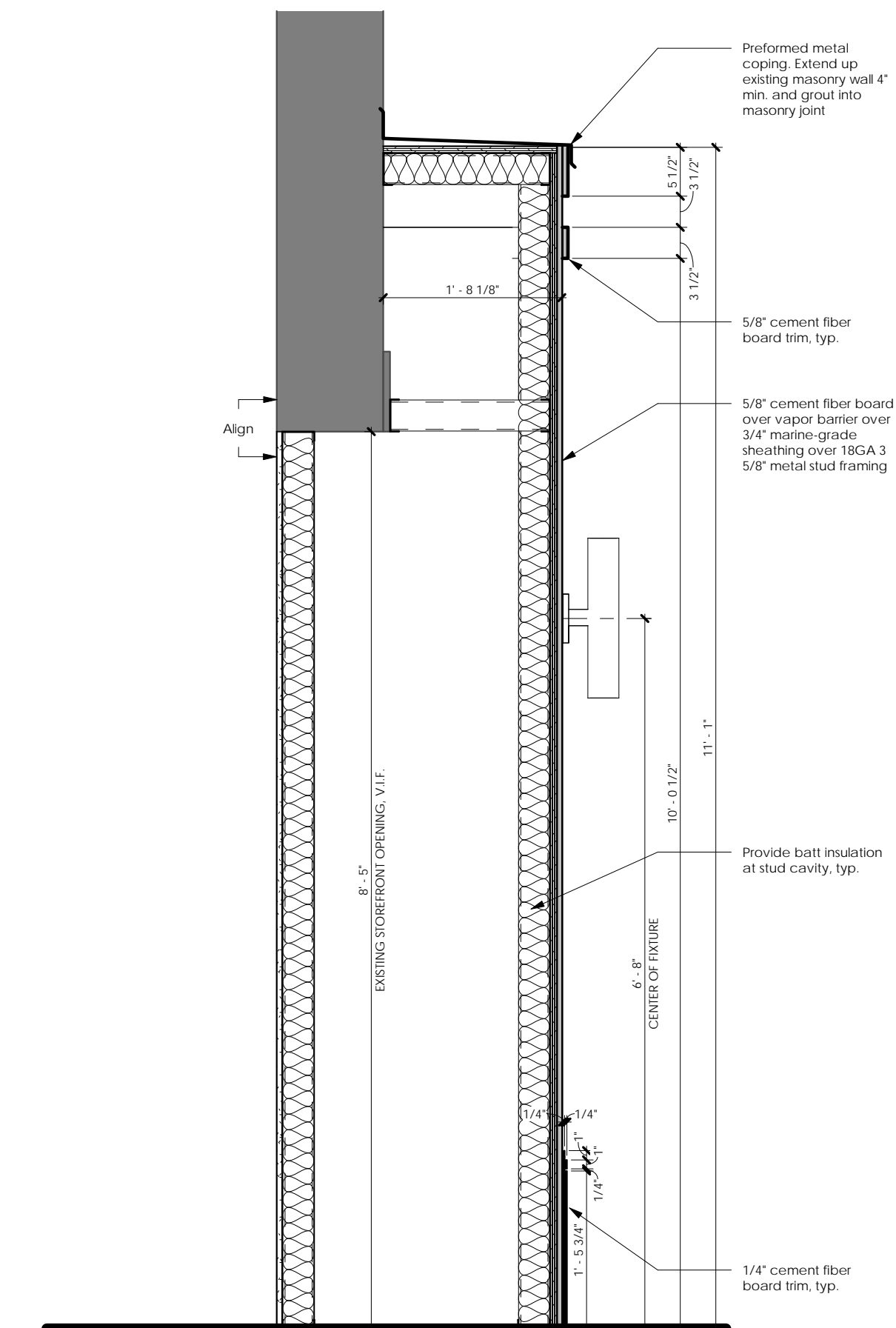

C Section
Scale: 3/4" = 1'-0"

SHEET NAME

Building Sections

SHEET NUMBER

A300