

VICINITY MAP

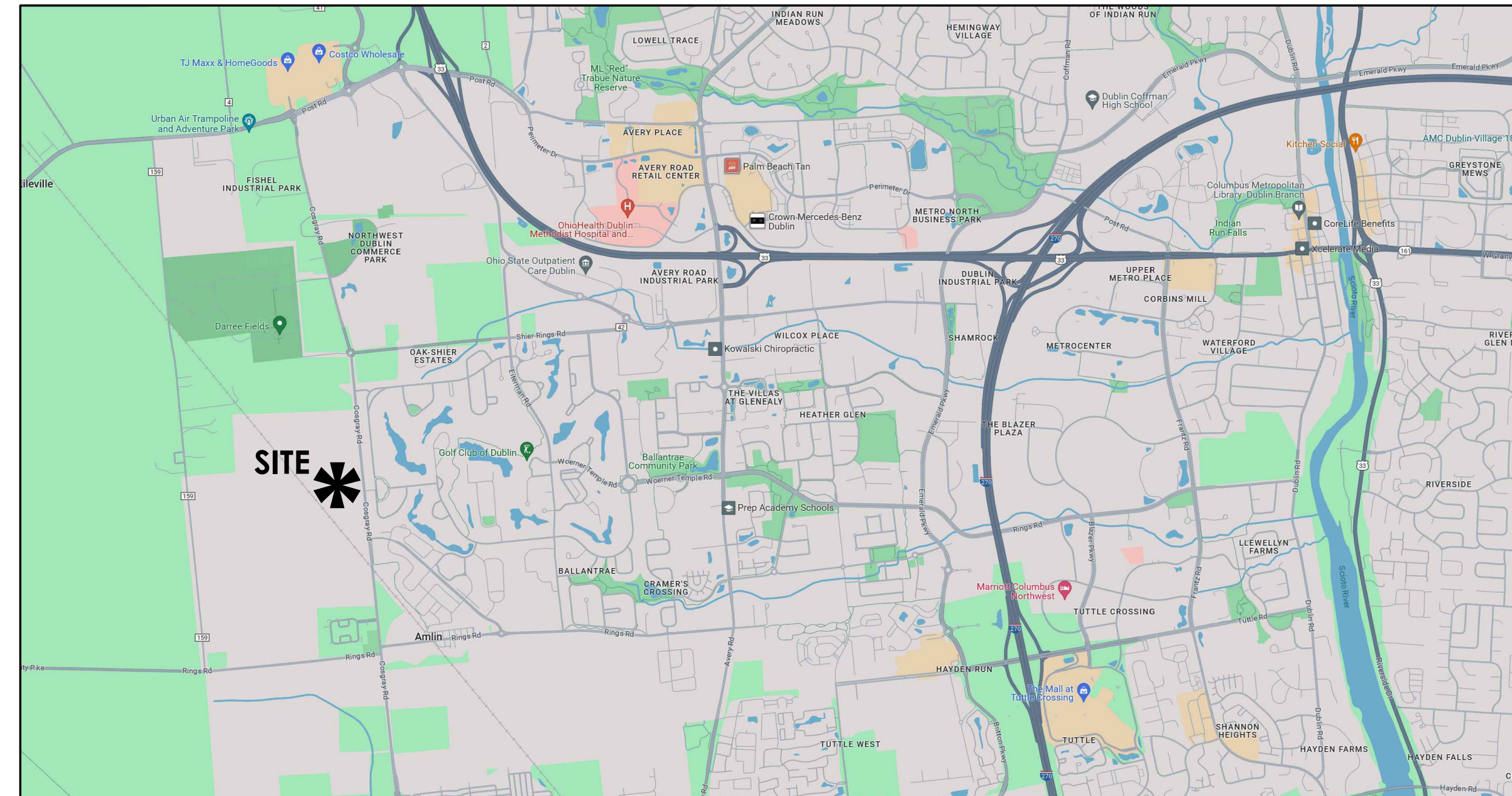

THE FARMS AT COSGRAY

PROJECT LOCATION

PREPARED FOR

COSGRAY ROAD LTD

6660 N High St STE 1E,
Worthington, OH 43085

PHONE: 309.825.8585

EMAIL: basireddy.kiran@gmail.com

PREPARED BY

Faris Planning & Design

LAND PLANNING

LANDSCAPE ARCHITECTURE

4876 Cemetery Road
p (614) 487-1964

Hilliard, OH 43026
www.farisplanninganddesign.com

LANDSCAPE PACKAGE CONTENTS

- L-1 PHOTO INVENTORY AND CONTEXT
- L-2 OPEN SPACE FRAMEWORK, STEP 1
- L-3 OPEN SPACE FRAME WORK, STEPS 2 & 3
- L-4 OPEN SPACE FRAMEWORK, STEP 4
- L-5 CONCEPT VIGNETTES
- L-6 CONCEPT PLAN
- L-7 OPEN SPACE PLAN
- A-1 ARCHITECTURAL ELEVATION, 55' WIDTH LOTS
- A-2 ARCHITECTURAL ELEVATION, 55' WIDTH LOTS
- A-3 ARCHITECTURAL ELEVATION, 55' WIDTH LOTS
- A-4 ARCHITECTURAL ELEVATION, 72' WIDTH LOTS
- A-5 ARCHITECTURAL ELEVATION, 72' WIDTH LOTS
- A-6 ARCHITECTURAL COLOR & MATERIAL PALETTES
- A-7 ARCHITECTURAL COLOR & MATERIAL PALETTES
- A-8 ARCHITECTURAL COLOR & MATERIAL PALETTES

SUBMISSION DATE:

04/19/24

REVISIONS:

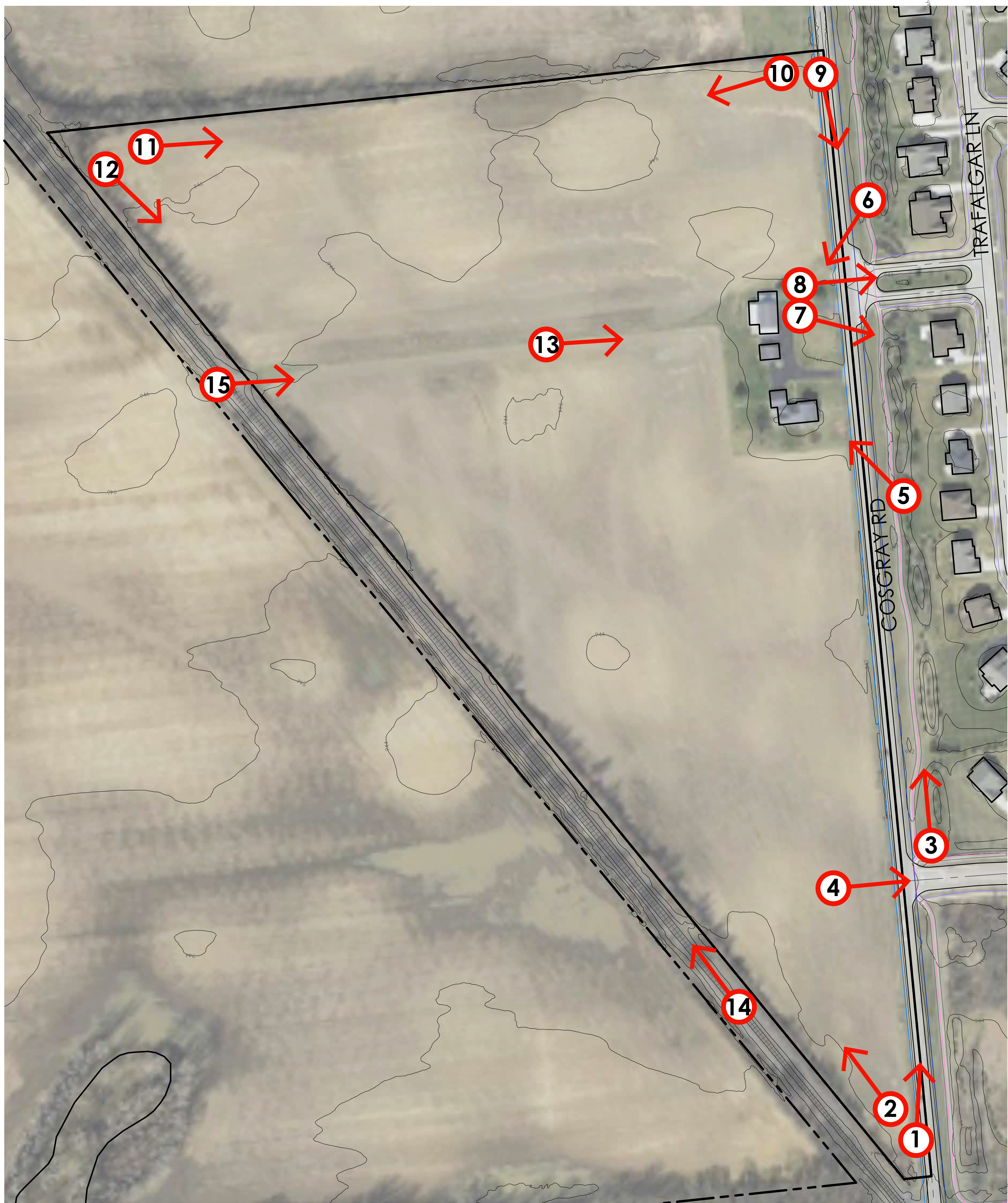
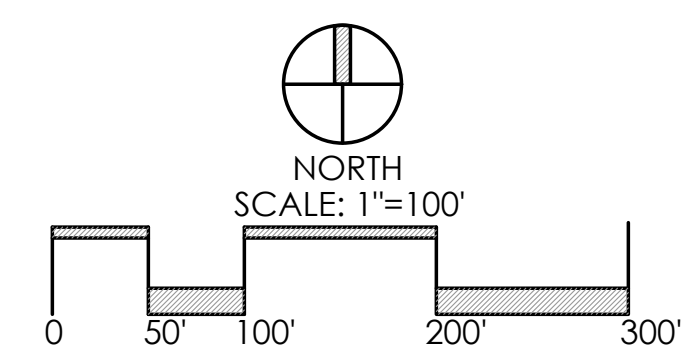

PHOTO INVENTORY AND SITE CONTEXT

THE FARMS AT COSGRAY

PREPARED FOR KIRAN BASIREDDY
DATE: 4.12.24



Faris Planning & Design

LAND PLANNING LANDSCAPE ARCHITECTURE
4876 Cemetery Road Hilliard, OH 43026
p. [614] 487-1964 www.farisplanninganddesign.com



1-A EXISTING DEVELOPMENT INVENTORY

1	EXISTING HISTORICAL HOME - BUILT 1890
2	EXISTING HISTORICAL BARN - BUILT 1910
3	EXISTING ASPHALT DRIVE AND PARKING

1-B EXISTING ZONING AND LAND USE

4	AGRICULTURAL FIELDS
5	RAILROAD LINE
6	GOLF COURSE
7	SINGLE FAMILY HOME

ZONING AREAS

RURAL	
PLANNED RESIDENTIAL DEVELOPMENT	
OPEN SPACE/PARK	

1-C PRELIMINARY EXTG. VEGETATION INVENTORY

A	TREES IN GOOD CONDITION (TYP)	
---	-------------------------------	--

1-D TOPOGRAPHIC & HYDROLOGIC INVENTORY

B	0-2.5% SLOPES (TYP)	
C	HIGH POINT OF SITE	
D	LOW POINT OF SITE	
E	FLOW LINES (TYP)	

1-E TRANSPORTATION & ACCESS INVENTORY

8	EXISTING MULTI-USE PATH	
9	EXISTING SIDEWALK	
*	ACCESS POINTS	

1-F EXISTING PUBLIC UTILITY SERVICE INVENTORY

10	EXISTING OVERHEAD ELECTRIC	
11	EXISTING WATER SERVICE	
*	EXISTING SANITARY SEWER TERMINUS	
*	EXISTING STORM SEWER	

1-G HISTORIC & CULTURAL ASSETS INVENTORY

1	EXISTING HISTORICAL HOME - BUILT 1890
2	EXISTING HISTORICAL BARN - BUILT 1910

SITE DATA

SITE ACREAGE	± 30.6 AC
--------------	-----------

OPEN SPACE FRAMEWORK - STEP 1- EXISTING CONDITIONS

THE FARMS AT COSGRAY

PREPARED FOR KIRAN BASIREDDY
DATE: 4.15.24

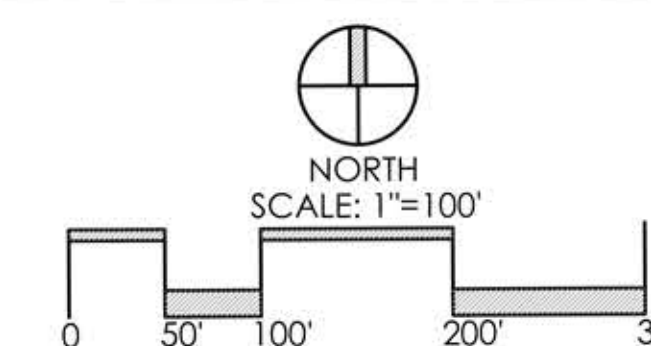



2 PRESERVATION/OPEN & DEVELOPABLE AREAS

(A)	PRESERVATION AREA 1 - EXISTING HISTORIC HOME TO BE PRESERVED	
(B)	PLANNED OPEN AREA/STORMWATER MANAGEMENT	
(C)	DEVELOPMENT AREA	

3 CONCEPTUAL STREET NETWORK & PATH SYSTEM

(1)	PRIMARY LOCAL ROAD - SIDEWALKS BOTH SIDES	
(2)	SECONDARY LOCAL ROAD - SIDEWALKS BOTH SIDES	
(3)	SHARED-USE PATHWAY	
(4)	FUTURE ROAD CONNECTION	

OPEN SPACE FRAMEWORK PLAN - STEPS 2 & 3

THE FARMS AT COSGRAY

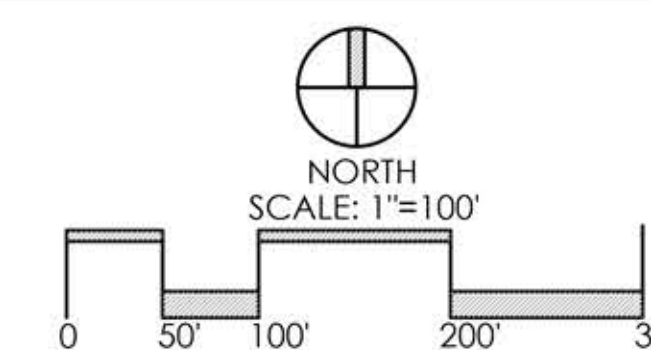

PREPARED FOR KIRAN BASIREDDY
DATE: 4.15.24



Faris Planning & Design

LAND PLANNING LANDSCAPE ARCHITECTURE
4876 Cemetery Road Hilliard, OH 43026
p (614) 487-1984 www.farisplanninganddesign.com

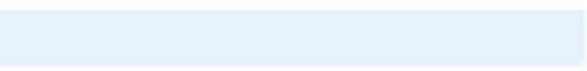
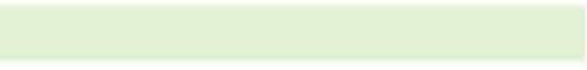
4 CONCEPT PLAN WITH LOT LINES

A	SINGLE FAMILY LOTS	
B	STORMWATER POND	
C	PERIMETER GREEN	
D	PRESERVED FARMHOUSE	



OPEN SPACE FRAMEWORK PLAN- STEP 4

THE FARMS AT COSGRAY

PREPARED FOR KIRAN BASIREDDY
DATE: 4.15.24

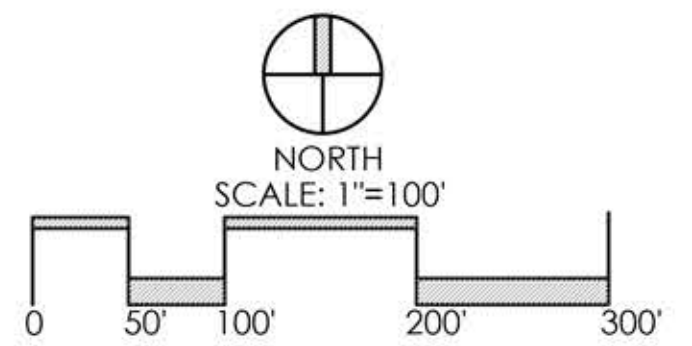

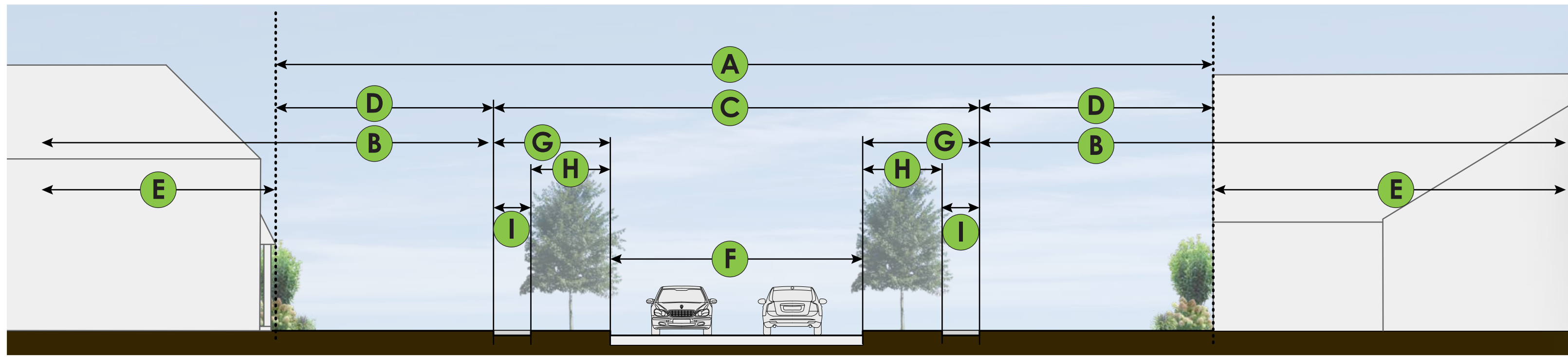

1 STREETScape ELEMENTS
SCALE 1:10

STREETScape ELEMENTS

- A** STREETScape
- B** PRIVATE LOT
- C** PUBLIC REALM (RIGHT-OF-WAY)
- D** SEMI-PRIVATE REALM
- E** PRIVATE REALM
- F** VEHICULAR REALM
- G** PEDESTRIAN REALM
- H** PLANTING/AMENITY ZONE
- I** SIDEWALK/SHARED-USE PATH ZONE

TYPICAL LOT ELEMENT DIMENSIONS

- 1** 25' MINIMUM FRONT BUILDING SETBACK (STAGGERED)
- 2** 25' CORNER SIDE BUILDING SETBACK
- 3** 6' MINIMUM SIDE YARD / 12' MINIMUM TOTAL SIDE YARD, BOTH SIDES
- 4** 8' MINIMUM SIDE YARD / 16' MINIMUM TOTAL SIDE YARD, BOTH SIDES
- 5** 25' REAR SETBACK - PRIVATE OPEN SPACE AREA
- 6** BUILDABLE AREA - PRINCIPAL STRUCTURE, 70' MAXIMUM DEPTH

TYPICAL BUILT CONDITIONS

- 7** ADDITIONAL PRIVATE OPEN SPACE AVAILABLE IN "UNBUILT" PORTIONS OF THE BUILDABLE AREA
- 8** HVAC EQUIPMENT REQUIRED BEHIND PRINCIPAL STRUCTURE
- 9** STREET FACING GARAGE
- 10** SIDE FACING GARAGE

TYPICAL LOT ELEMENT DIMENSIONS

- A** 55' LOT WIDTH
- B** 72' LOT WIDTH

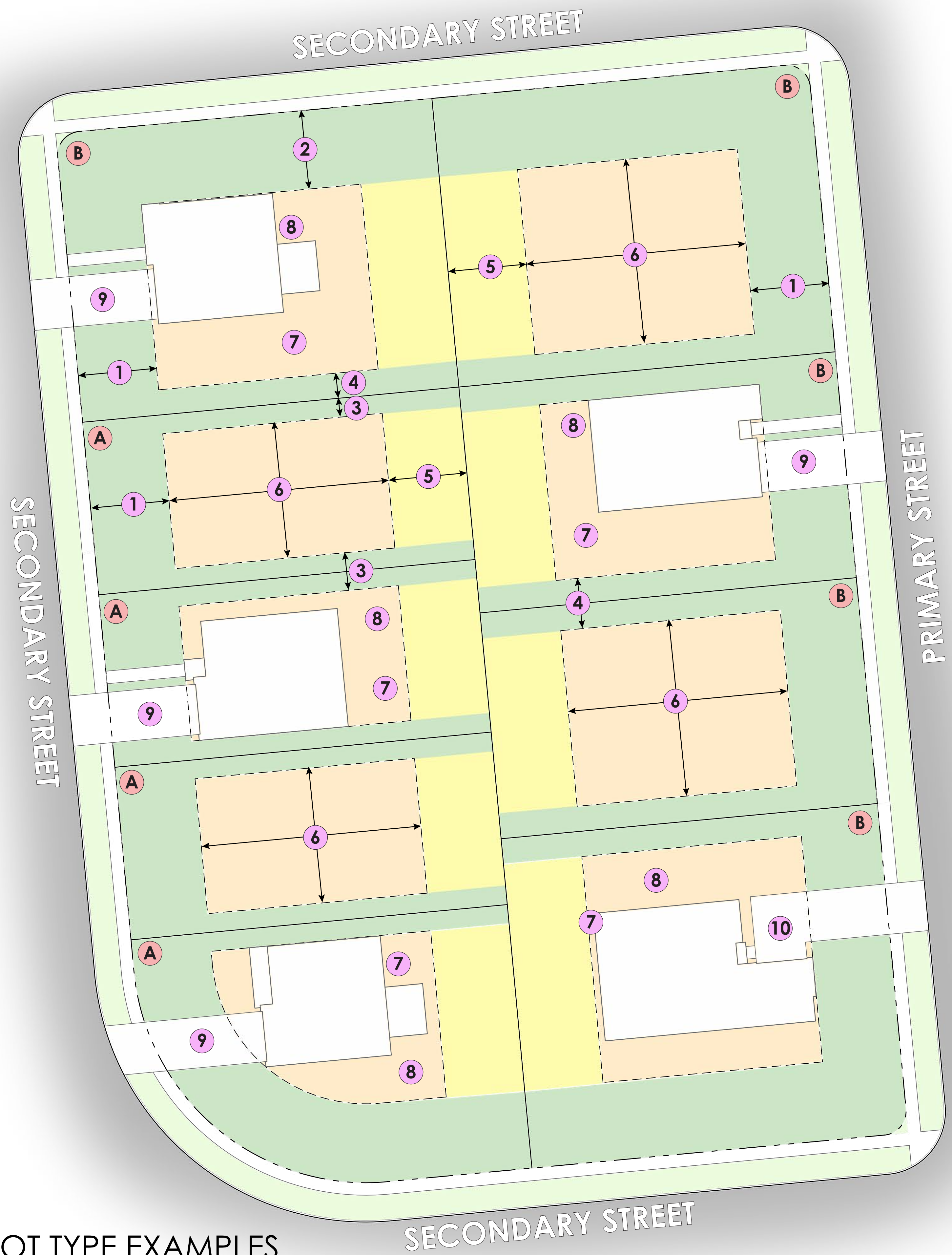

2 LOT TYPE EXAMPLES
SCALE 1:10

CONCEPT PLAN VIGNETTES

THE FARMS AT COSGRAY

PREPARED FOR KIRAN BASIREDDY
DATE: 4.16.24

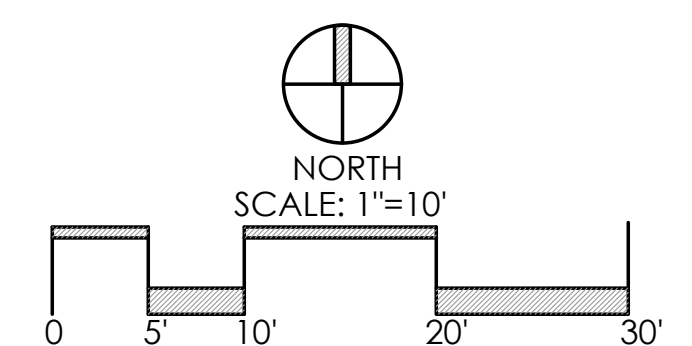

Faris Planning & Design
LAND PLANNING LANDSCAPE ARCHITECTURE
4876 Cemetery Road Hilliard, OH 43026
p. (614) 487-1964 www.farisplanninganddesign.com



SITE DATA

TOTAL ACRES	+/- 30.6 ACRES
TOTAL LOTS	52 LOTS
55' LOTS	15
72' LOTS	37
DENSITY	+/- 1.69 D.U./AC.

CONCEPT PLAN

THE FARMS AT COSGRAY

PREPARED FOR KIRAN BASIREDDY
DATE: 4.16.24

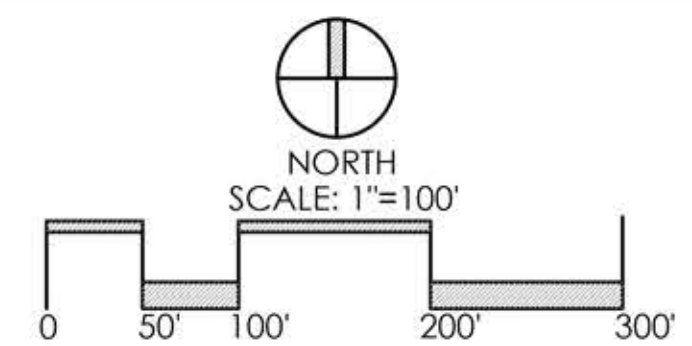



SITE DATA

TOTAL ACRES	+/- 30.6 ACRES
TOTAL OPEN SPACE	+/- 14.0 ACRES (45.6%)

CONCEPT OPEN SPACE PLAN

THE FARMS AT COSGRAY

PREPARED FOR KIRAN BASIREDDY
DATE: 4.16.24

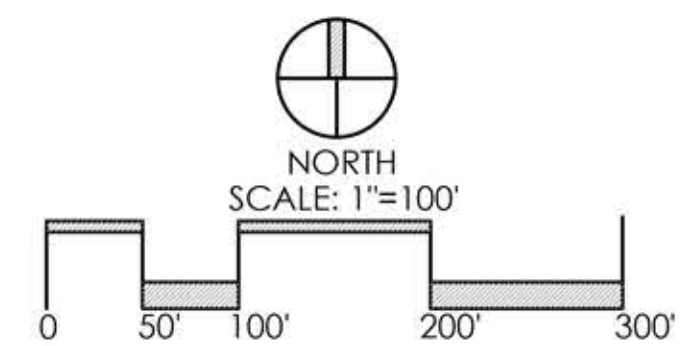

LINDEN | DESIGNER COLLECTION

AMERICAN CLASSIC w/ INC. SIDING EXTERIOR DESIGN

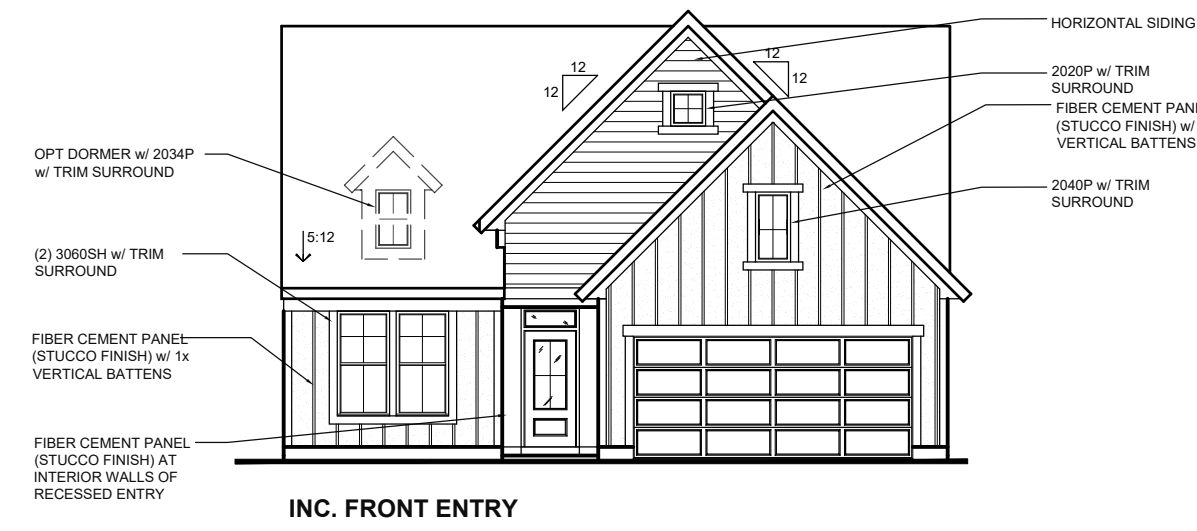

INC. FRONT ENTRY

MODERN FARMHOUSE w/ INC. SIDING EXTERIOR DESIGN

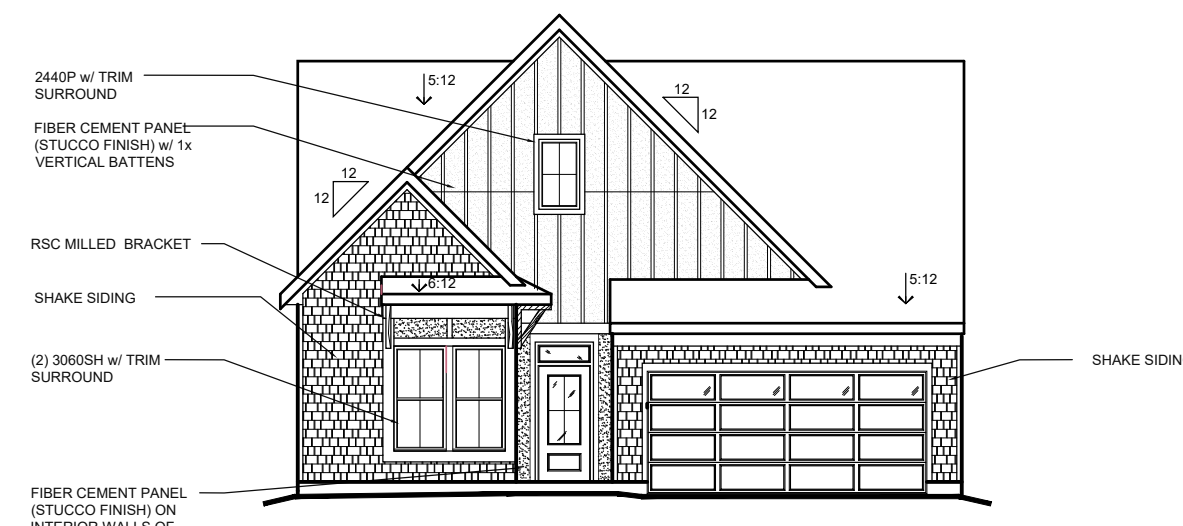

INC. FRONT ENTRY

COASTAL COTTAGE w/ INC. SIDING EXTERIOR DESIGN

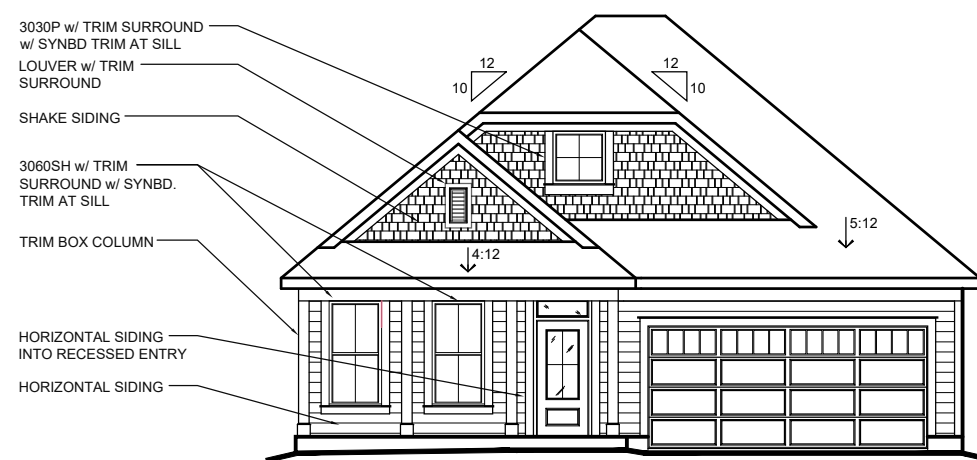

FRONT ENTRY w/ INCLUDED SIDING

AMERICAN CLASSIC w/ OPT. BRICK VENEER EXTERIOR DESIGN



INC. FRONT ENTRY (AVAILABLE w/ LOW OR HIGH BRICK SIDES AND REAR)

MODERN FARMHOUSE w/ OPT. CULTURED STONE VENEER EXTERIOR DESIGN

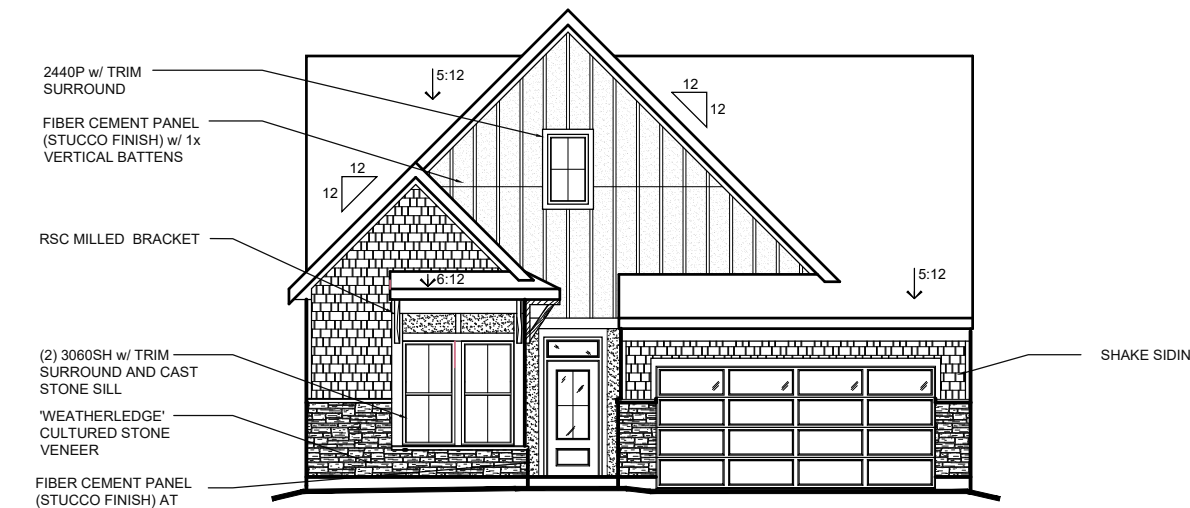

INC. FRONT ENTRY (AVAILABLE w/ LOW STONE SIDES AND REAR)

COASTAL COTTAGE w/ OPT. CULTURED STONE VENEER EXTERIOR DESIGN

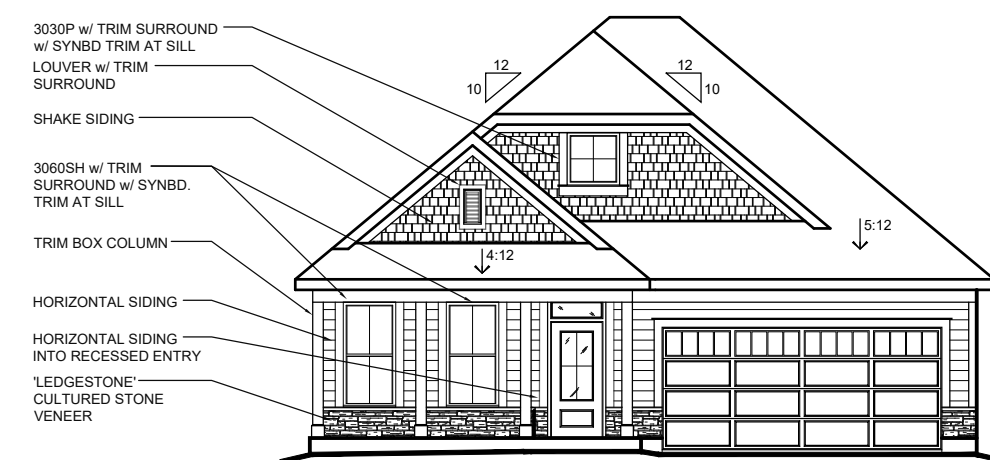

FRONT ENTRY w/ OPT. CULTURED STONE VENEER (AVAILABLE w/ LOW STONE SIDES AND REAR)

OLIVE | DESIGNER COLLECTION

MODERN FARMHOUSE w/ INC. SIDING EXTERIOR DESIGN



FRONT ENTRY w/ INCLUDED SIDING

COASTAL CLASSIC w/ INC. SIDING EXTERIOR DESIGN

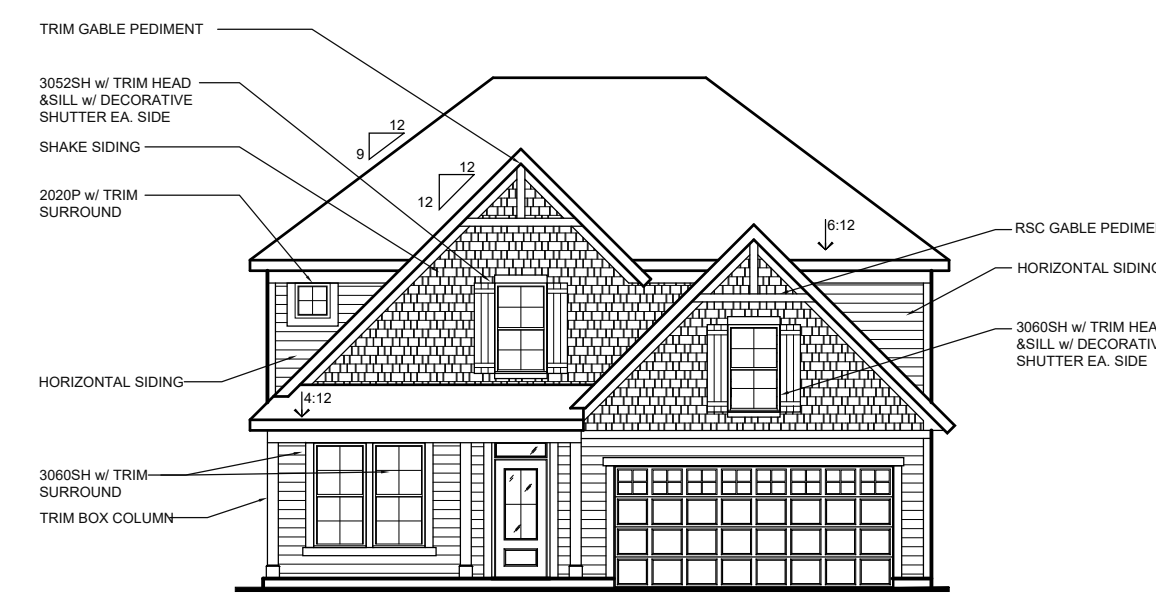

FRONT ENTRY w/ INCLUDED SIDING

COASTAL CLASSIC w/ BRICK VENEER | EXTERIOR DESIGN

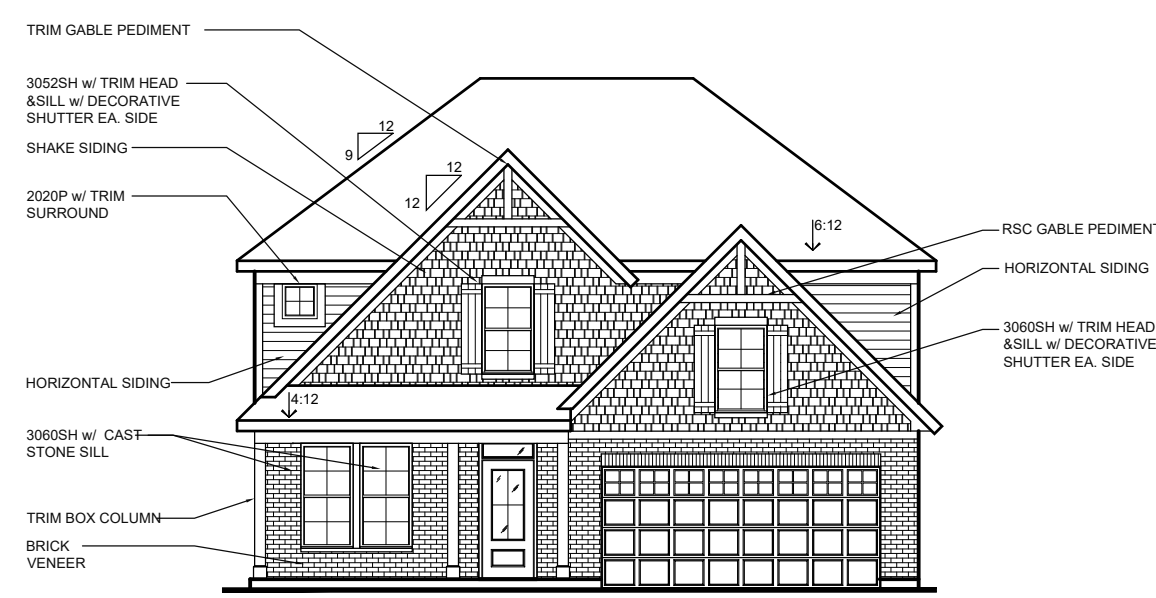

FRONT ENTRY w/ OPT. BRICK VENEER (AVAILABLE w/ LOW AND HIGH BRICK SIDES AND REAR)

MODERN FARMHOUSE w/ OPT. BRICK VENEER EXTERIOR DESIGN



FRONT ENTRY w/ OPT. BRICK VENEER (AVAILABLE w/ LOW OR HIGH BRICK SIDES AND REAR)

COASTAL CLASSIC w/ OPT. CULTURED STONE VENEER | EXTERIOR DESIGN

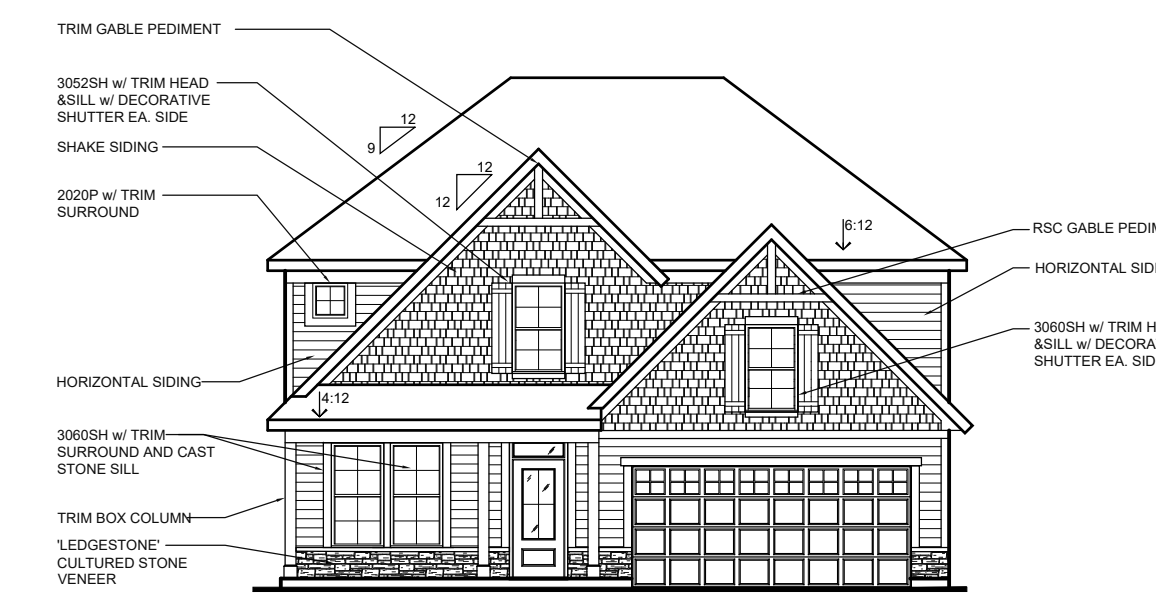

FRONT ENTRY w/ OPT. CULTURED STONE VENEER (AVAILABLE w/ LOW STONE SIDES AND REAR)

MODERN RETREAT w/ INC. BRICK VENEER | EXTERIOR DESIGN (ADDS 66 SF TO TOTAL)

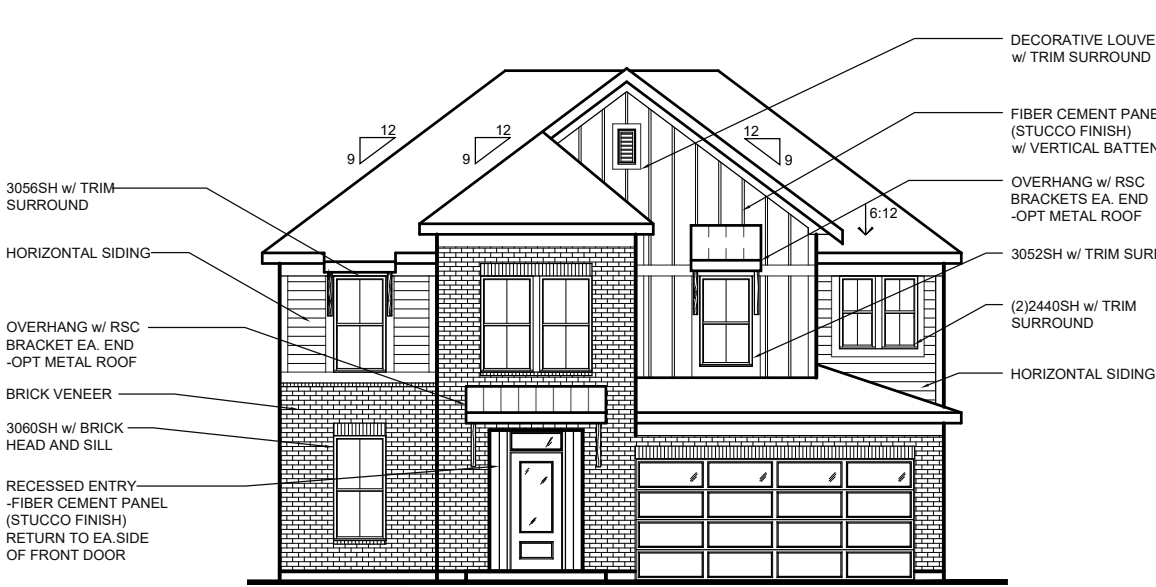

FRONT ENTRY w/ BRICK VENEER (AVAILABLE w/ LOW OR HIGH BRICK SIDES AND REAR)

ARCHITECTURAL ELEVATIONS - 55' WIDTH LOTS

A-1

THE FARMS AT COSGRAY

PREPARED FOR KIRAN BASIREDDY
DATE: 4.17.24

Faris Planning & Design

LAND PLANNING LANDSCAPE ARCHITECTURE
4876 Cemetery Hilliard, OH 43026
p. [614] 487-1964 www.farisplanninganddesign.com

BIRCH | DESIGNER COLLECTION

INC. MODERN FARMHOUSE w/ INC. SIDING | EXTERIOR DESIGN

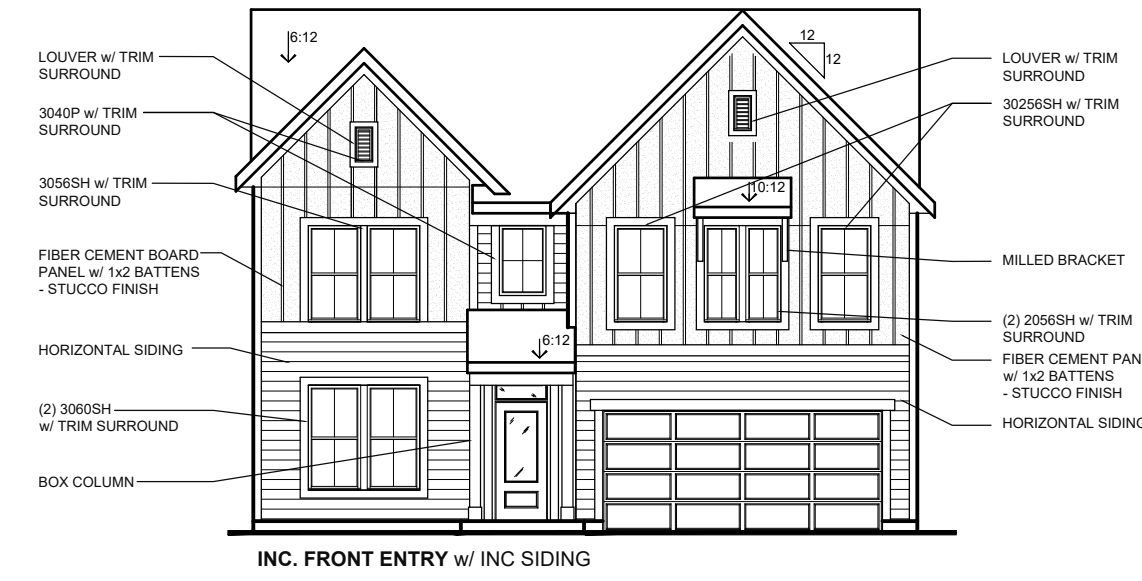

MODERN FARMHOUSE w/ OPT. BRICK VENEER | EXTERIOR DESIGN

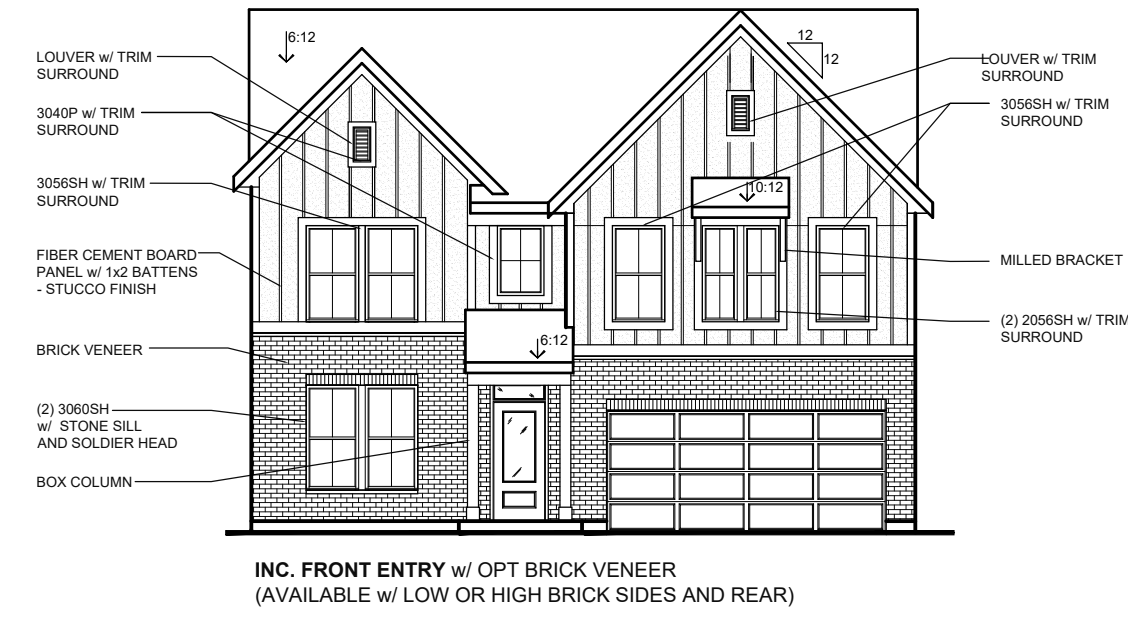

AMERICAN CLASSIC w/ INC. SIDING | EXTERIOR DESIGN

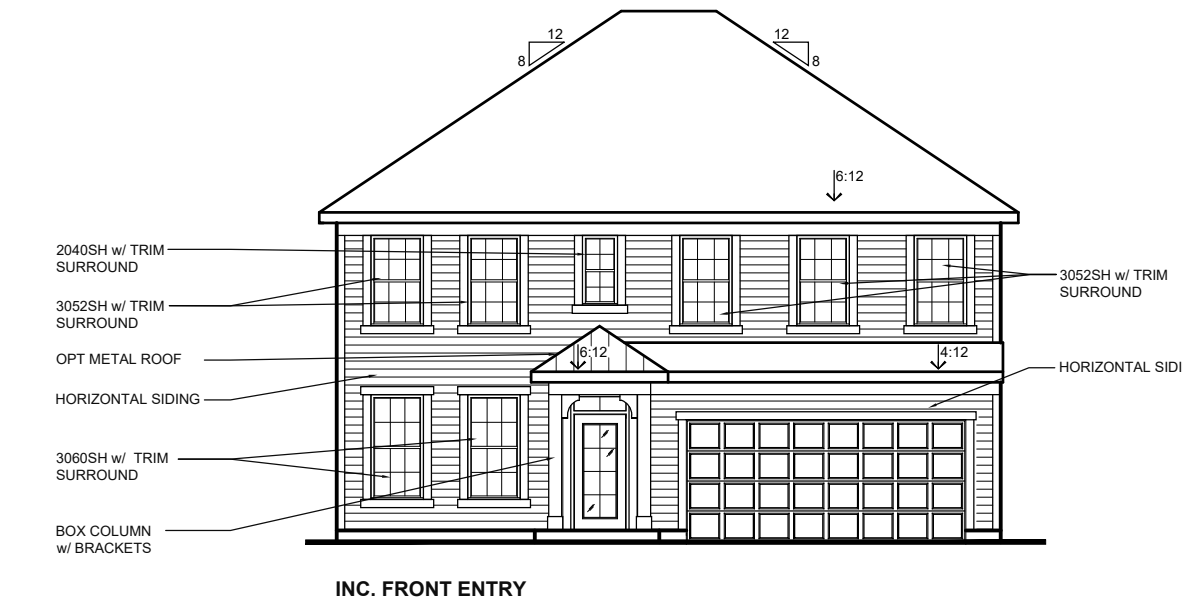

AMERICAN CLASSIC w/ OPT. CULTURED STONE VENEER | EXTERIOR DESIGN



MODERN EUROPEAN w/ INC. SIDING | EXTERIOR DESIGN

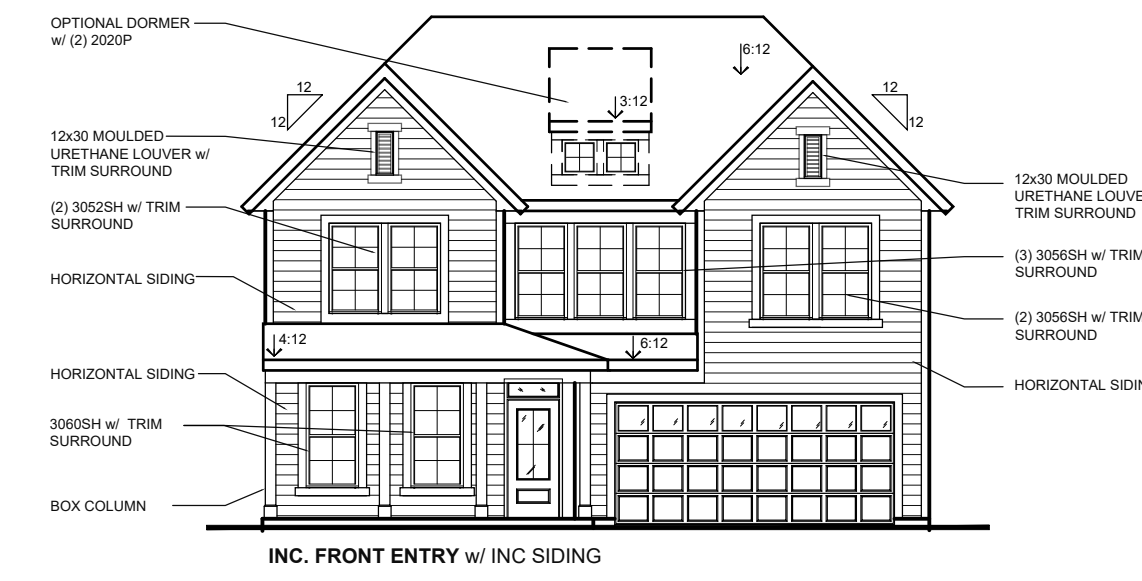

MODERN EUROPEAN w/ OPT. BRICK VENEER | EXTERIOR DESIGN

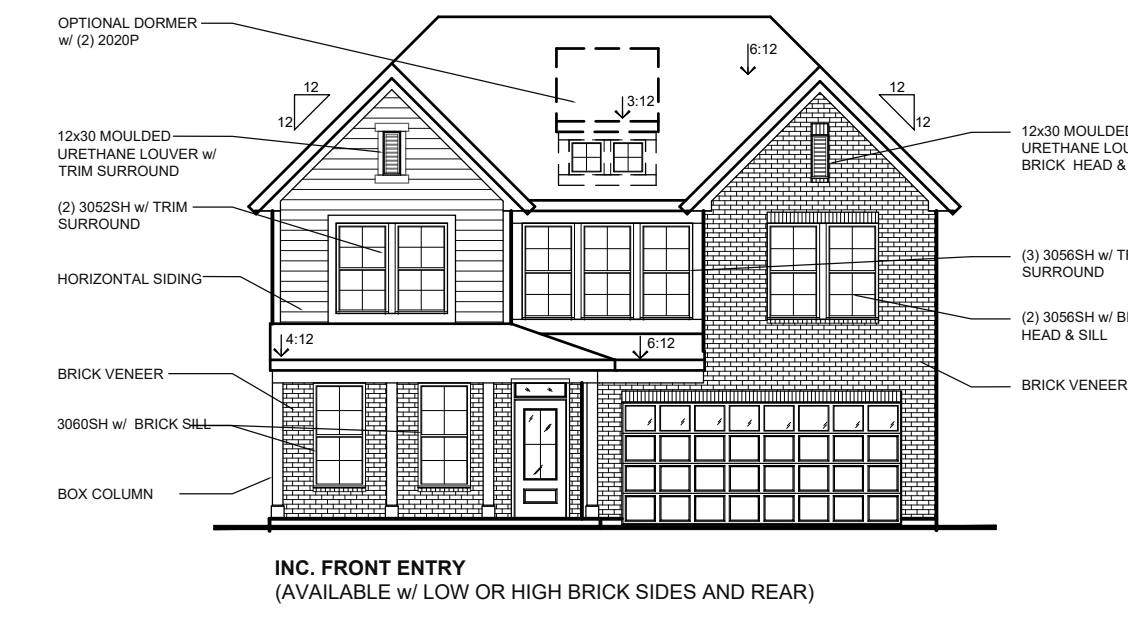

MODERN RETREAT w/ INC. SIDING | EXTERIOR DESIGN



MODERN RETREAT w/ OPT. BRICK VENEER | EXTERIOR DESIGN

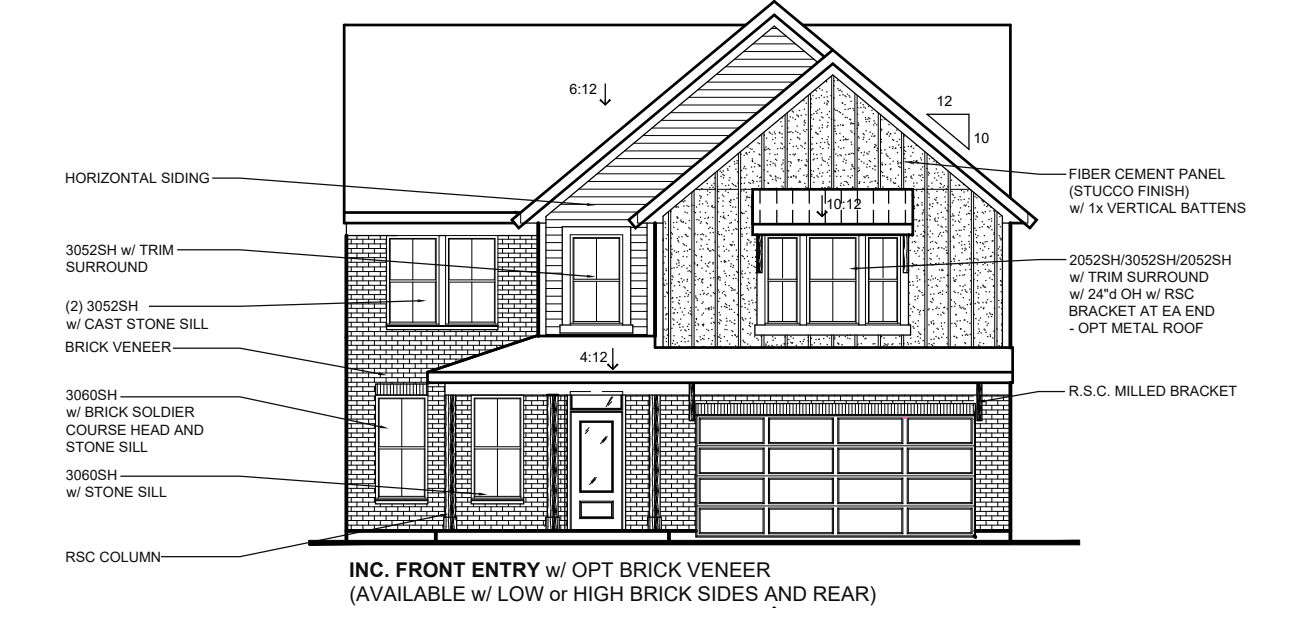

MODERN EUROPEAN w/ OPT. CULTURED STONE VENEER | EXTERIOR DESIGN

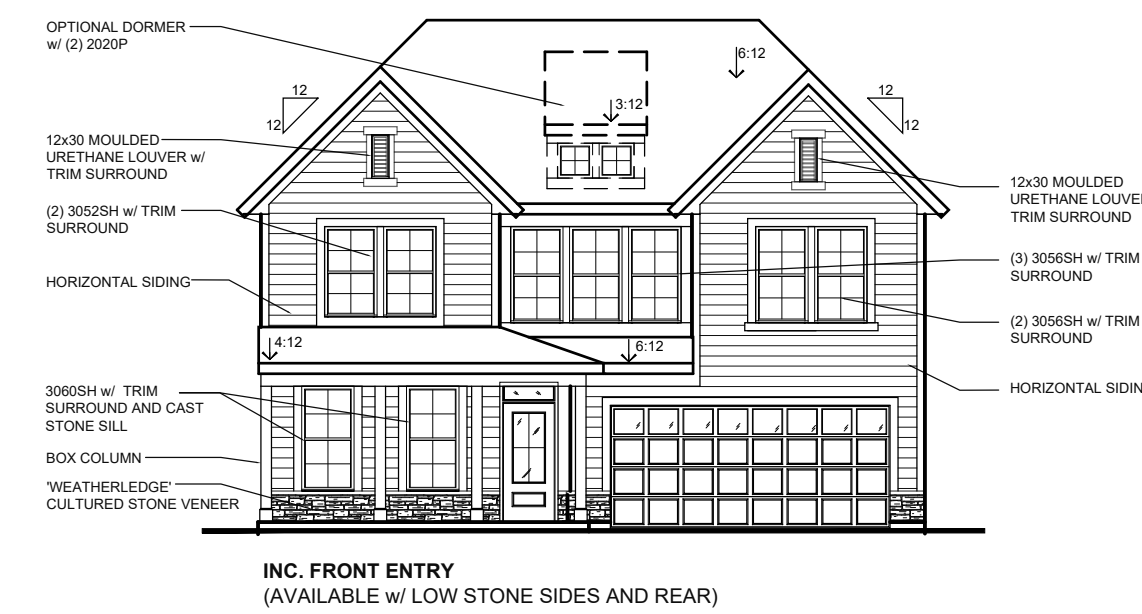

PACIFIC CRAFTSMAN w/ OPT. CULTURED STONE VENEER | EXTERIOR DESIGN

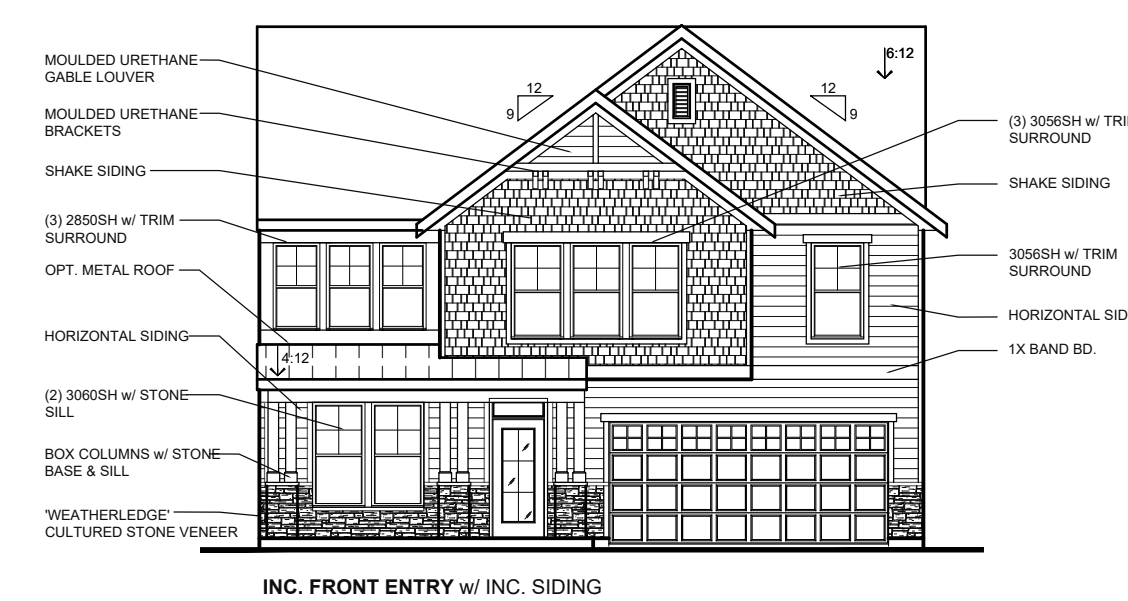

WESTERN CRAFTSMAN w/ INC. SIDING | EXTERIOR DESIGN

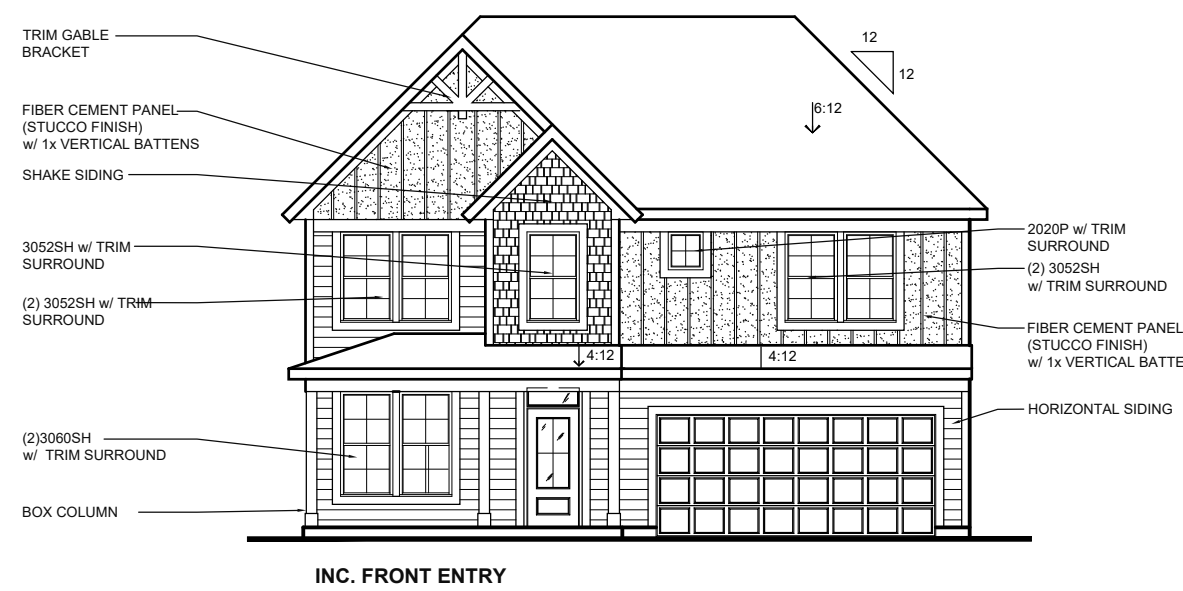

WESTERN CRAFTSMAN w/ OPT. BRICK VENEER | EXTERIOR DESIGN

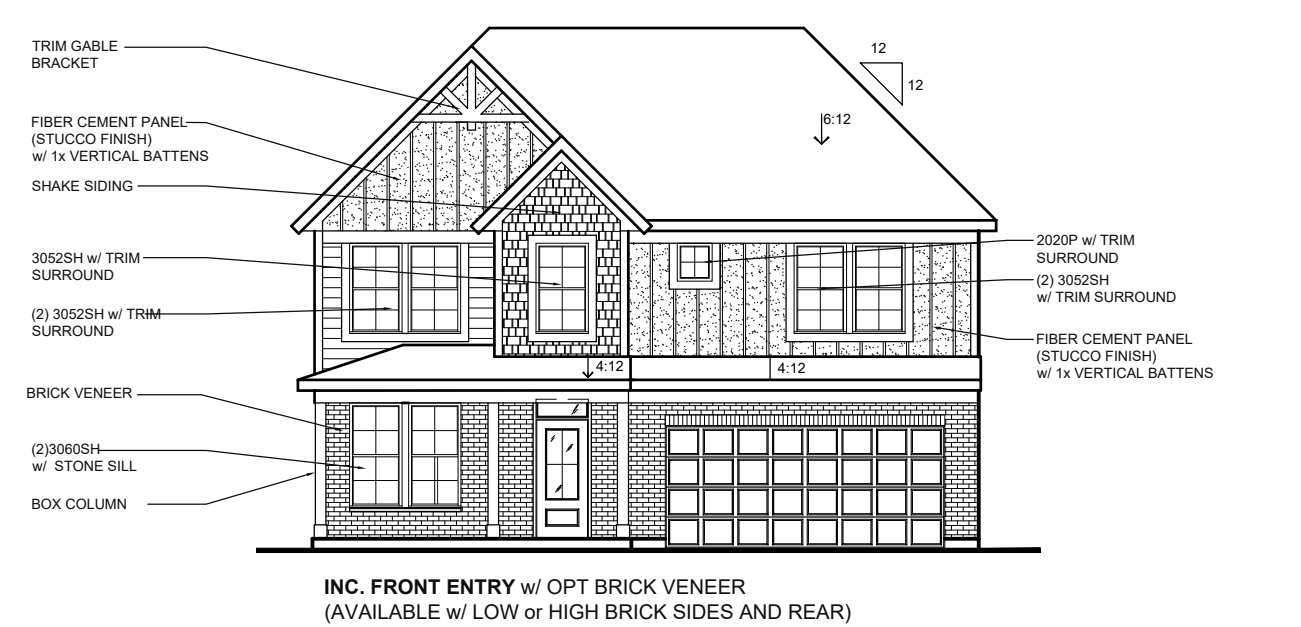

EDENTON | PATIO COLLECTION

AMELIA | PATIO COLLECTION

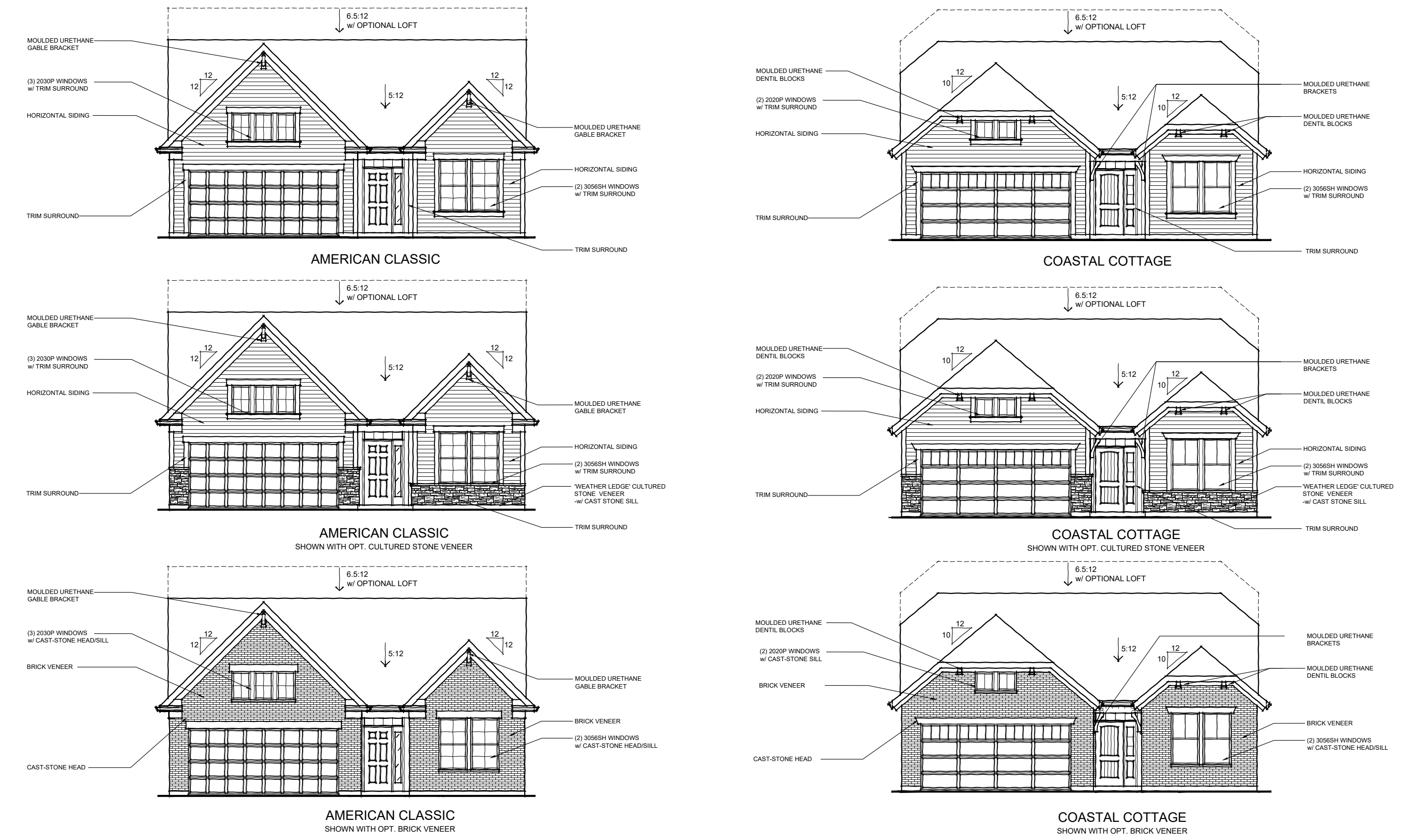
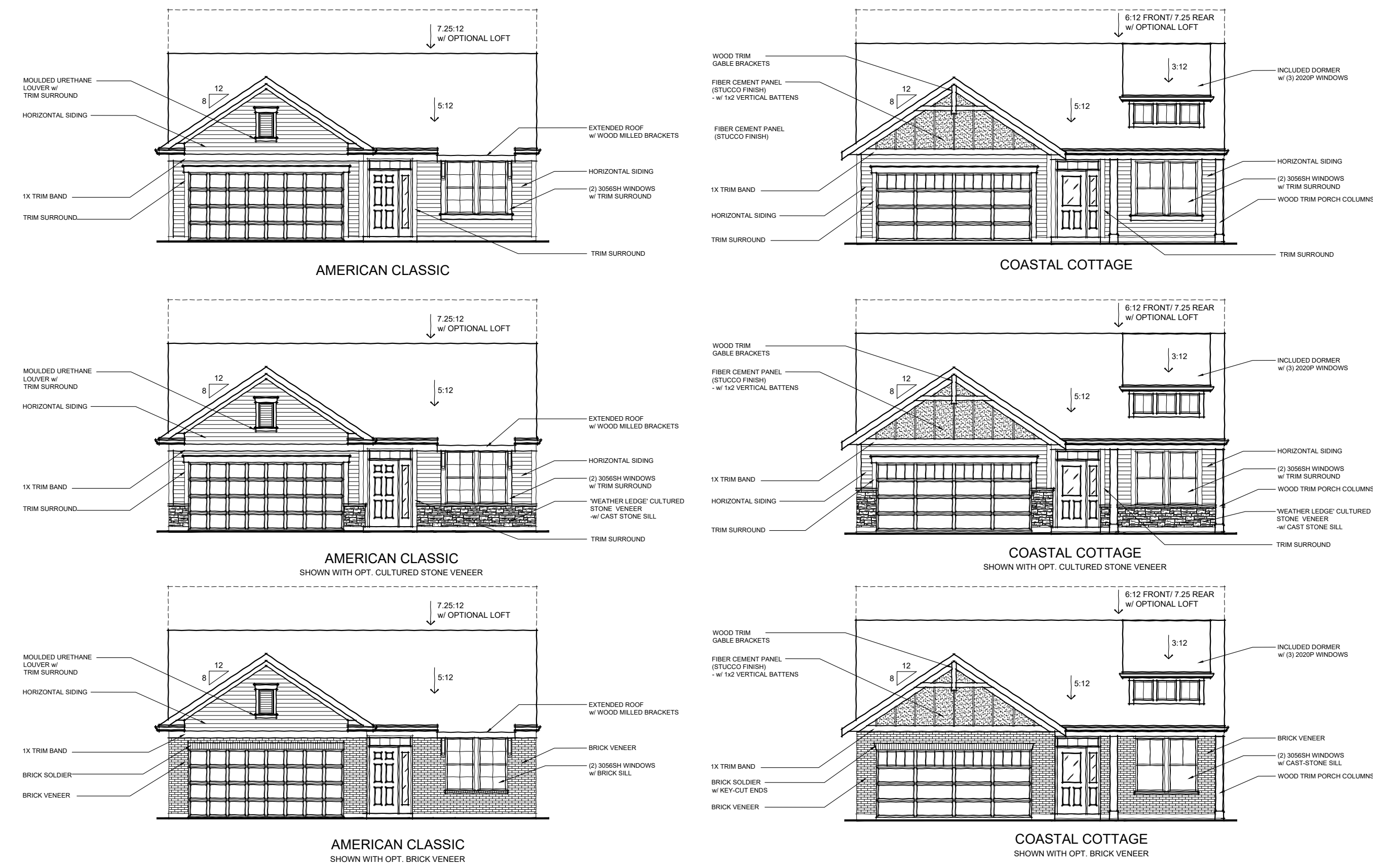

WILMINGTON | PATIO COLLECTION

MAXWELL | PATIO COLLECTION

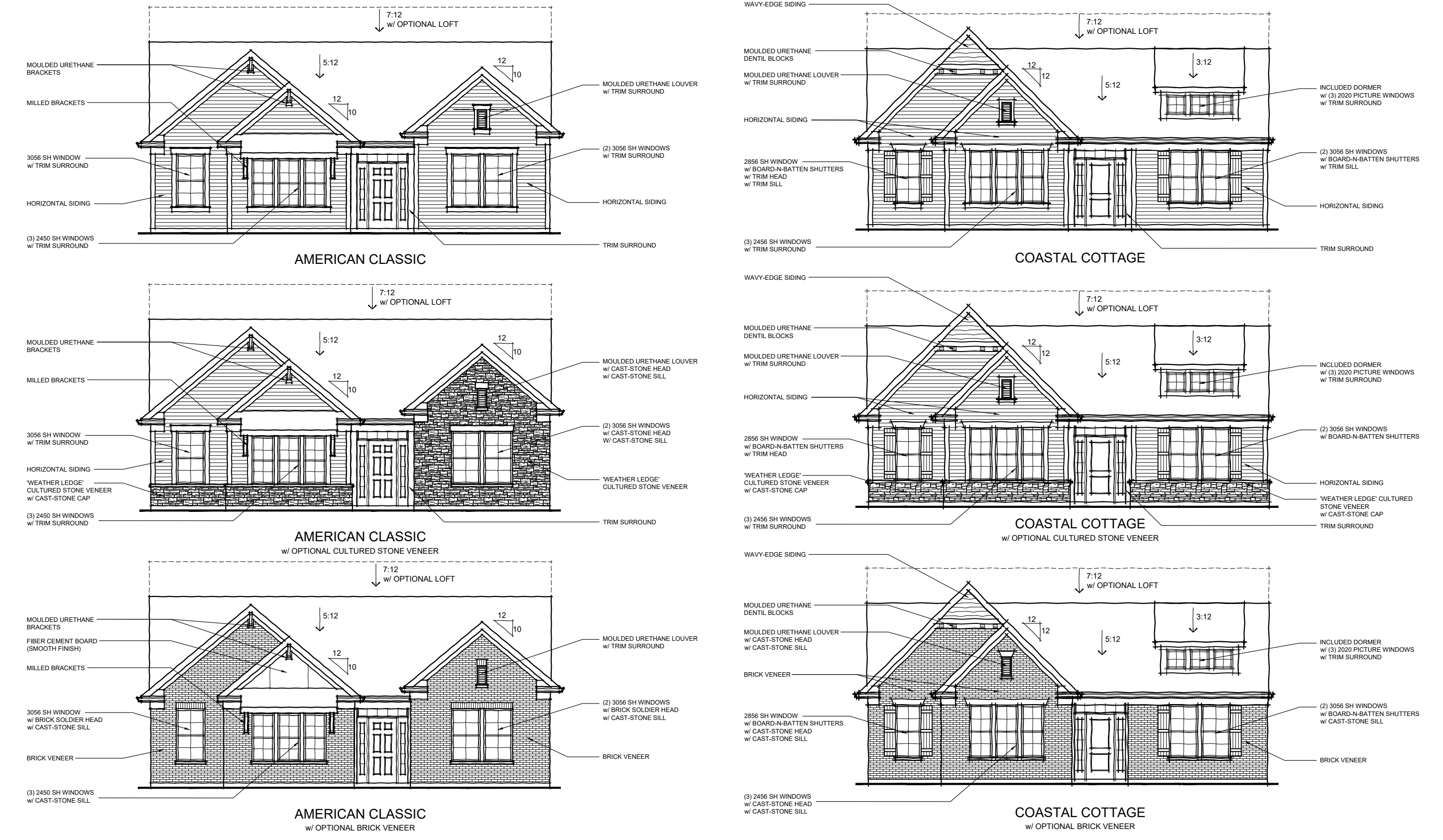
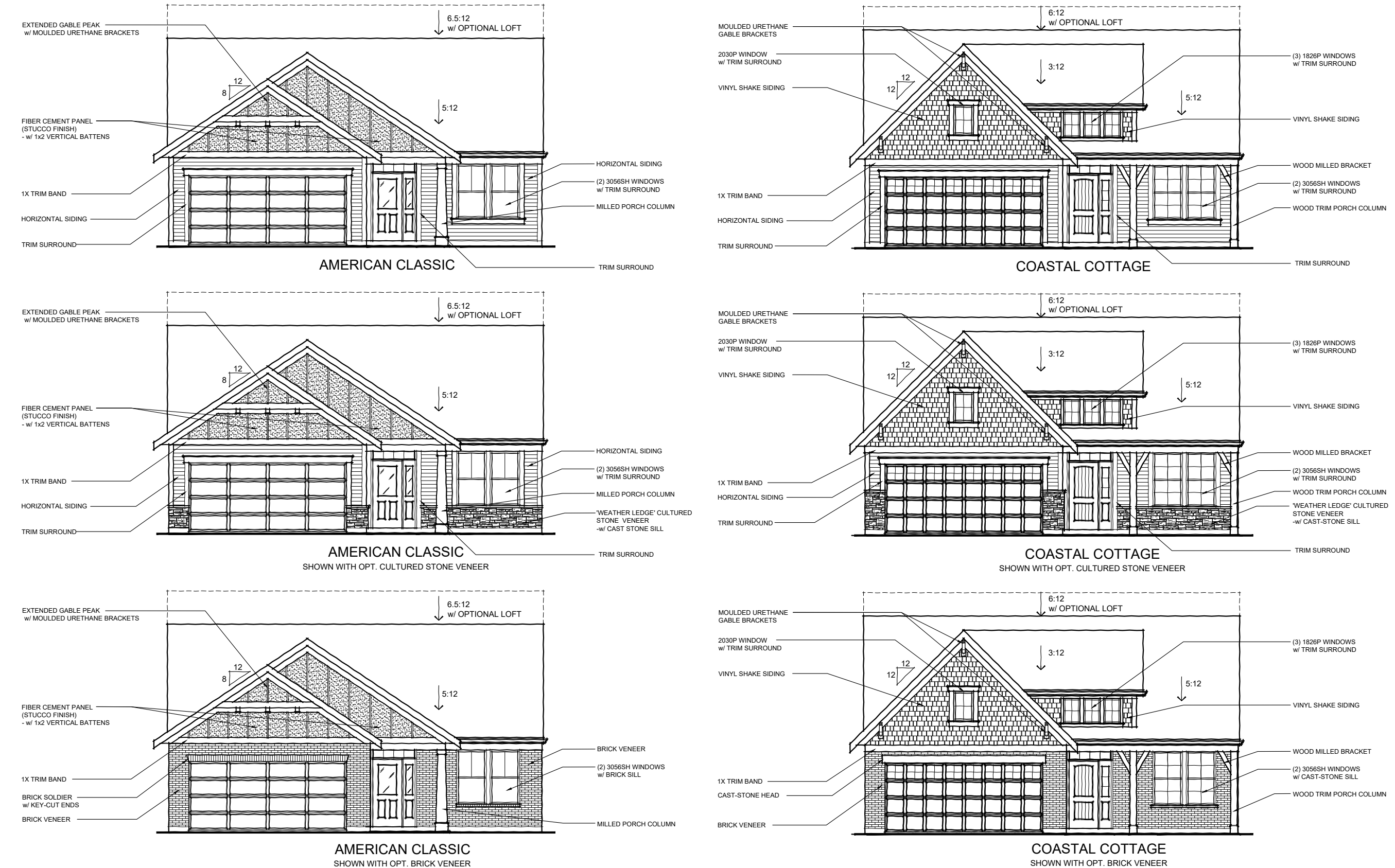

ARCHITECTURAL ELEVATIONS - 72' WIDTH LOTS

A-4

THE FARMS AT COSGRAY

PREPARED FOR KIRAN BASIREDDY

DATE: 4.17.24

Faris Planning & Design

LAND PLANNING

LANDSCAPE ARCHITECTURE

4876 Cemetery
p. [614] 487-1964

Hilliard, OH 43026
www.farisplanninganddesign.com

CAMDEN | PATIO COLLECTION

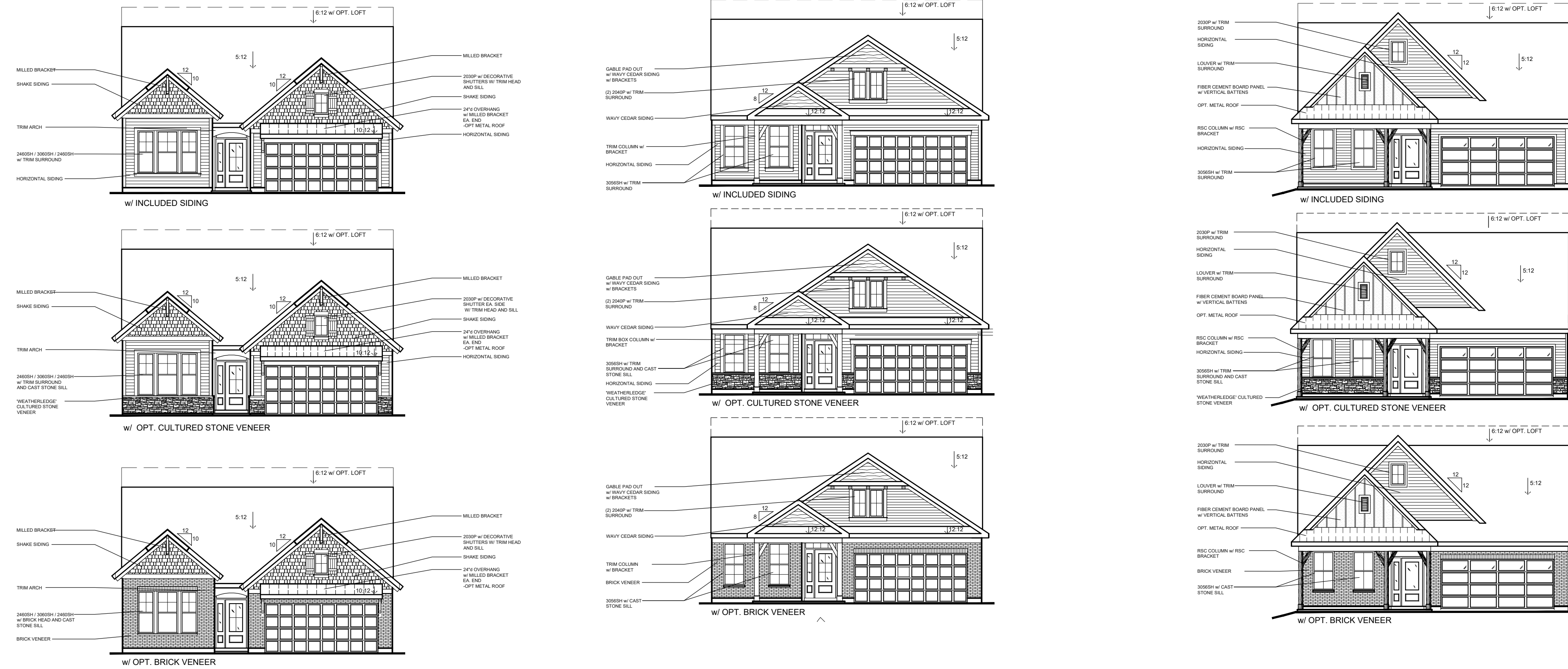

MORGAN | PATIO COLLECTION

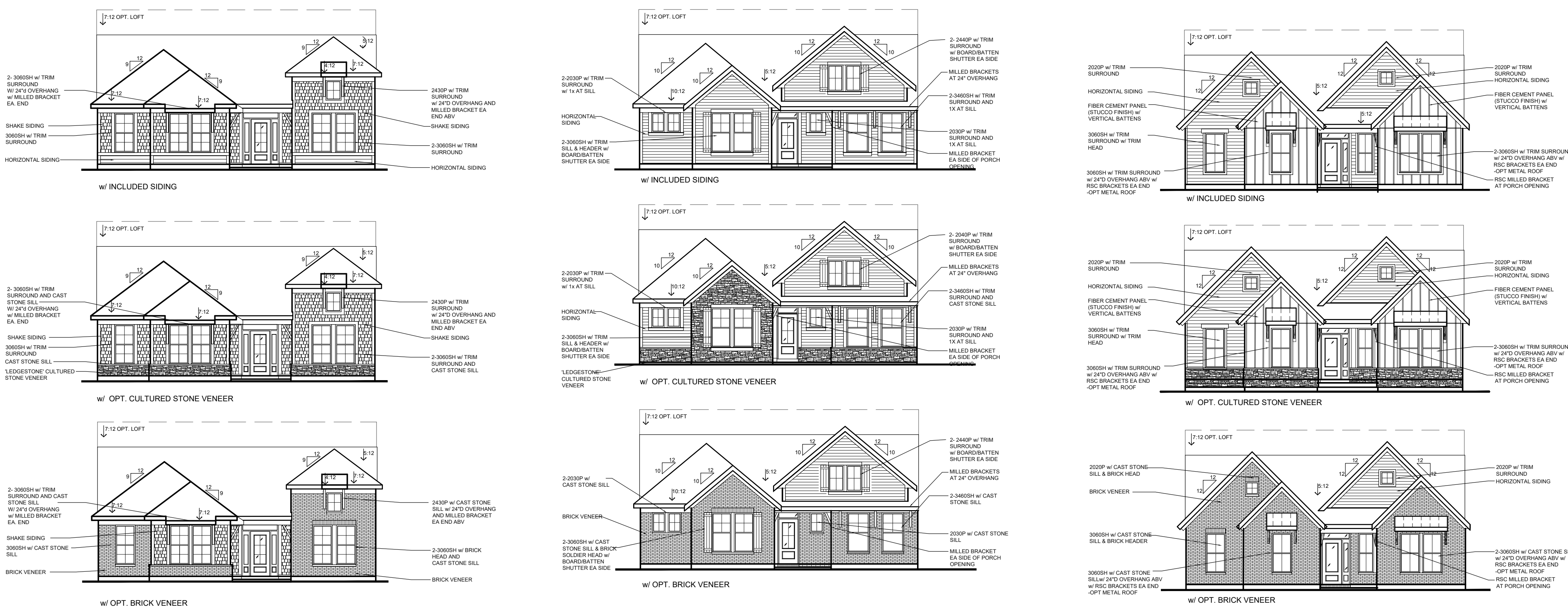

ARCHITECTURAL ELEVATIONS - 72' WIDTH LOTS

A-5

THE FARMS AT COSGRAY

PREPARED FOR KIRAN BASIREDDY
DATE: 4.17.24

Faris Planning & Design

LAND PLANNING LANDSCAPE ARCHITECTURE
4876 Cemetery Hilliard, OH 43026
p. [614] 487-1964 www.farisplanninganddesign.com

COLOR PACKAGE A

Trim and Garage Door:
Shark PPG1006-2

Included Shingles: Weathered Gray

Community Specific Shingles: Weathered Wood

Horizontal Siding: Pebblestone Clay (Stonehenge Greige PPG1024-5)

Hardie Panel/Board & Batten: Moth Gray PPG1024-4

Shake Siding: Cocoa (Ground Coffee PPG1076-7)

Cultured Stone: Sienna Weather Ledge

Wavy Edge Siding: Port Wine SC-1064

Shutters: Burgundy Wine PPG1053-7

Entry Door Color Options:
Gunmetal Gray PPG1033-6, Starless Sky PPG0995-7, Burgundy Wine PPG1053-7

NOTE: Gutter and downspout color to match Trim color.

FISCHER HOMES
4.11.2024

Note: Color swatches are approximate but not accurate. Please refer to the Lifestyle Design Center for exact color samples.

COLOR PACKAGE B

Trim and Garage Door:
Shark PPG1006-2

Included Shingles: Weathered Gray

Community Specific Shingles: Weathered Wood

Horizontal Siding: Deep Granite (Industrial Revolution PPG0997-6)

Hardie Panel/Board & Batten: Felted Wool PPG0997-2

Shake Siding: Oceanside (Freedom Found PPG 1040-6)

Cultured Stone: Elkwood Weather Ledge

Wavy Edge Siding: Cape Code Gray SC-1012

Shutters: Starless Sky PPG0995-7

Entry Door Color Options:
Burgundy Wine PPG1053-7, Starless Sky PPG0995-7, Freedom Found PPG1040-6

NOTE: Gutter and downspout color to match Trim color.

FISCHER HOMES
4.11.2024

Note: Color swatches are approximate but not accurate. Please refer to the Lifestyle Design Center for exact color samples.

COLOR PACKAGE C

Trim and Garage Door:
Shark PPG1006-2

Included Shingles: Weathered Gray

Community Specific Shingles: Weathered Wood

Horizontal Siding: Quiet Willow (Sagebrook PPG2)

Hardie Panel/Board & Batten: Aldabra PPG14-28

Shake Siding: Sandalwood (Rocky Road PPG1000-2)

Cultured Stone: Sagewood Weather Ledge

Wavy Edge Siding: Olive Wood SC-1056

Shutters: Spiced Wine PPG1016-7

Entry Door Color Options:
Spiced Wine PPG1016-7, Undercover PPG0998-7, Prairie Fire PPG1071-8

NOTE: Gutter and downspout color to match Trim color.

FISCHER HOMES
4.11.2024

Note: Color swatches are approximate but not accurate. Please refer to the Lifestyle Design Center for exact color samples.

COLOR PACKAGE D

Trim and Garage Door:
Shark PPG1006-2

Included Shingles: Weathered Gray

Community Specific Shingles: Weathered Wood

Horizontal Siding: Desert Sand (Moth Gray PPG1024-4)

Hardie Panel/Board & Batten: Tortuga PPG1032-5

Shake Siding: Shadow (Stonehenge Greige PPG1024-5)

Cultured Stone: Sienna Weather Ledge

Wavy Edge Siding: Olive Wood SC-1056

Shutters: Gunmetal Gray PPG1033-6

Entry Door Color Options:
Black Magic PPG1001-7, Gunmetal Gray PPG1033-6, Burgundy Wine PPG1053-7

NOTE: Gutter and downspout color to match Trim color.

FISCHER HOMES
4.11.2024

Note: Color swatches are approximate but not accurate. Please refer to the Lifestyle Design Center for exact color samples.

COLOR PACKAGE E

Trim and Garage Door:
Shark PPG1006-2

Included Shingles: Weathered Gray

Community Specific Shingles: Weathered Wood

Horizontal Siding: Montana Suede (Granite PPG1022-6)

Hardie Panel/Board & Batten: Moth Gray PPG1024-4

Shake Siding: Shadow (Stonehenge Greige PPG1024-5)

Cultured Stone: Natural Blend Weather Ledge

Wavy Edge Siding: Bayberry SC-1008

Shutters: Merlot PPG13-04

Entry Door Color Options:
Black Magic PPG1001-7, Merlot PPG13-04, Enchanting Eggplant PPG13-07

NOTE: Gutter and downspout color to match Trim color.

FISCHER HOMES
4.11.2024

COLOR PACKAGE F

Trim and Garage Door:
Shark PPG1006-2

Included Shingles: Weathered Gray

Community Specific Shingles: Weathered Wood

Horizontal Siding: Harbor Gray (Burnished Blade PPG0995-5)

Hardie Panel/Board & Batten: Freedom Found PPG1040-6

Shake Siding: Moonlight (Felted Wool PPG0997-2)

Cultured Stone: Prestige Weather Ledge

Wavy Edge Siding: Cape Code Gray SC-1012

Shutters: Cavalry PPG1041-7

Entry Door Color Options:
Merlot PPG13-04, Black Widow PPG0997-7, Cavalry PPG1041-7

NOTE: Gutter and downspout color to match Trim color.

FISCHER HOMES
4.11.2024

COLOR PACKAGE G

Trim and Garage Door:
Shark PPG1006-2

Included Shingles: Weathered Gray

Community Specific Shingles: Weathered Wood

Horizontal Siding: Harbor Gray (Burnished Blade PPG0995-5)

Hardie Panel/Board & Batten: Felted Wool PPG0997-2

Shake Siding: Moss (Tortuga PPG1031-5)

Cultured Stone: Elkwood Weather Ledge

Brick: Bourbon Trail

Shutters: Black Magic PPG1001-7

Wavy Edge Siding: Phoenix Fossil SC-1060

Entry Door Color Options:
Burgundy Wine PPG1055-7, Black Widow PPG0997-7, Black Magic PPG1001-7

NOTE: Gutter and downspout color to match Trim color.

FISCHER HOMES
4.11.2024

COLOR PACKAGE H

Trim and Garage Door:
Shark PPG1006-2

Included Shingles: Weathered Gray

Community Specific Shingles: Weathered Wood

Horizontal Siding: Desert Sand (Moth Gray PPG1024-4)

Hardie Panel/Board & Batten: Ground Coffee PPG1076-7

Shake Siding: Shadow (Stonehenge Greige PPG1024-5)

Cultured Stone: Pennsylvania Weather Ledge

Brick: Pin Oak

Shutters: Plunge Pool PPG1029-7

Wavy Edge Siding: Oxford Brown SC-1058

Entry Door Color Options:
Black Walnut PPG1014-7, Merlot PPG13-04, Plunge Pool PPG1029-7

NOTE: Gutter and downspout color to match Trim color.

FISCHER HOMES
4.11.2024

COLOR PACKAGE I

Trim and Garage Door:
Shark PPG1006-2

Included Shingles: Weathered Gray

Community Specific Shingles: Weathered Wood

Horizontal Siding: Quiet Willow (Sagebrook PPG2)

Hardie Panel/Board & Batten: Dancing Dolphin PPG1102-3

Shake Siding: Shadow (Stonehenge Greige PPG1024-5)

Cultured Stone: Sagewood Weather Ledge

Brick: Lanes End

Shutters: Black Magic PPG001-7

Wavy Edge Siding: Drift SC1027

Entry Door Color Options:
Merlot PPG13-04, Black Magic PPG001-7, Armory PPG1009-6

Note: Color swatches are approximate but not accurate. Please refer to the Lifestyle Design Center for exact color samples.

FISCHER HOMES

4.11.2024

COLOR PACKAGE J

Trim and Garage Door:
Shark PPG1006-2

Included Shingles: Weathered Gray

Community Specific Shingles: Weathered Wood

Horizontal Siding: Misty Shadow (Armory PPG1009-6)

Hardie Panel/Board & Batten: Rocky Road PPG1000-2

Shake Siding: Shadow (Stonehenge Greige PPG1024-5)

Cultured Stone: Natural Blend Weather Ledge

Brick: Oak Reserve

Shutters: Undercover PPG098-7

Wavy Edge Siding: Olive Wood SC-1056

Entry Door Color Options:
Prairie Fire PPG1071-6, Spiced Wine PPG1016-7, Undercover PPG098-7

Note: Color swatches are approximate but not accurate. Please refer to the Lifestyle Design Center for exact color samples.

FISCHER HOMES

4.11.2024

COLOR PACKAGE K

Trim and Garage Door:
Shark PPG1006-2

Included Shingles: Weathered Gray

Community Specific Shingles: Weathered Wood

Horizontal Siding: English Wedgewood (Garrison Gray PPG1039-5)

Hardie Panel/Board & Batten: Greyhound PPG1008-3

Shake Siding: Sahara (Moth Gray PPG1024-4)

Cultured Stone: Prestige Weather Ledge

Brick: Farmington

Shutters: Undercover PPG098-7

Wavy Edge Siding: Jefferson Tan SC-1041

Entry Door Color Options:
Black Walnut PPG1014-7, Artillery PPG1008-6, Undercover PPG098-7

Note: Color swatches are approximate but not accurate. Please refer to the Lifestyle Design Center for exact color samples.

FISCHER HOMES

4.11.2024