



Monterey Drive Redevelopment Dublin Concept Plan

MAY 20, 2024

archall



Monterey Drive Redevelopment

PROPOSED MIXED-USE DEVELOPMENT

DUBLIN CONCEPT PLAN

MAY 20, 2024



DEVELOPER



PROJECT BRIEF

This 6 acre development is proposed in two parts; 1.5 story (one occupiable story) retail frontage at the northern portion of the site, and sale of 53 townhome lots to a third-party builder on the southern portion.

The retail portion of the project is comprised of four buildings connected to the parking lot behind via breezeways. The design incorporates architectural styles similar to those found in Historic Dublin to create an inviting retail presence along Bridge Street. The townhouse portion of the development proposes 3-story, attached garage townhouses. Combined, the two will bring ground-floor commercial activation to the Bridge Street corridor and will deliver a new single-family, for-sale housing product to the area within walking distance of Historic Dublin and Bridge Park.

TABLE OF CONTENTS

- 01** Cover
- 02** Project Summary
- 03** Site Context
- 07** Proposed Architectural Design
- 12** Proposed Views
- 19** Civil Drawings
- 30** Proposed Townhouse Design

Site Context

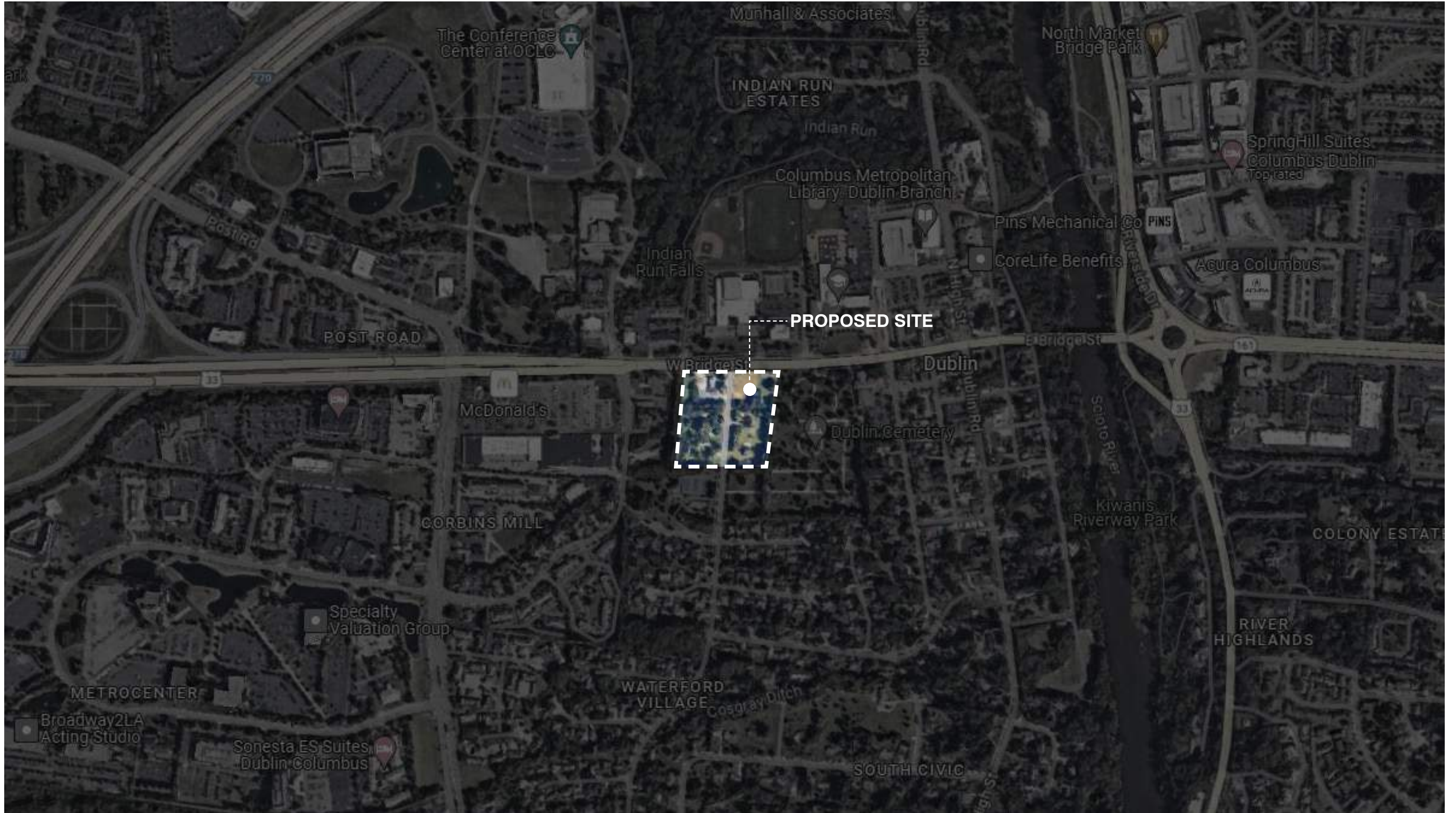



BRIDGE STREET

PROPOSED SITE

MONTEREY DRIVE



Proposed Architectural Design

BUILDING AREA TOTALS:	
WEST BUILDING: 4,820 SF + 5,880 SF	= 10,700 SF
EAST BUILDING: 3,660 + 5,056 SF	= 8,716 SF
TOTAL BUILDING AREA:	19,416 SF
TOTAL PATIO AREA:	2,960 SF

W BRIDGE ST

W BRIDGE ST

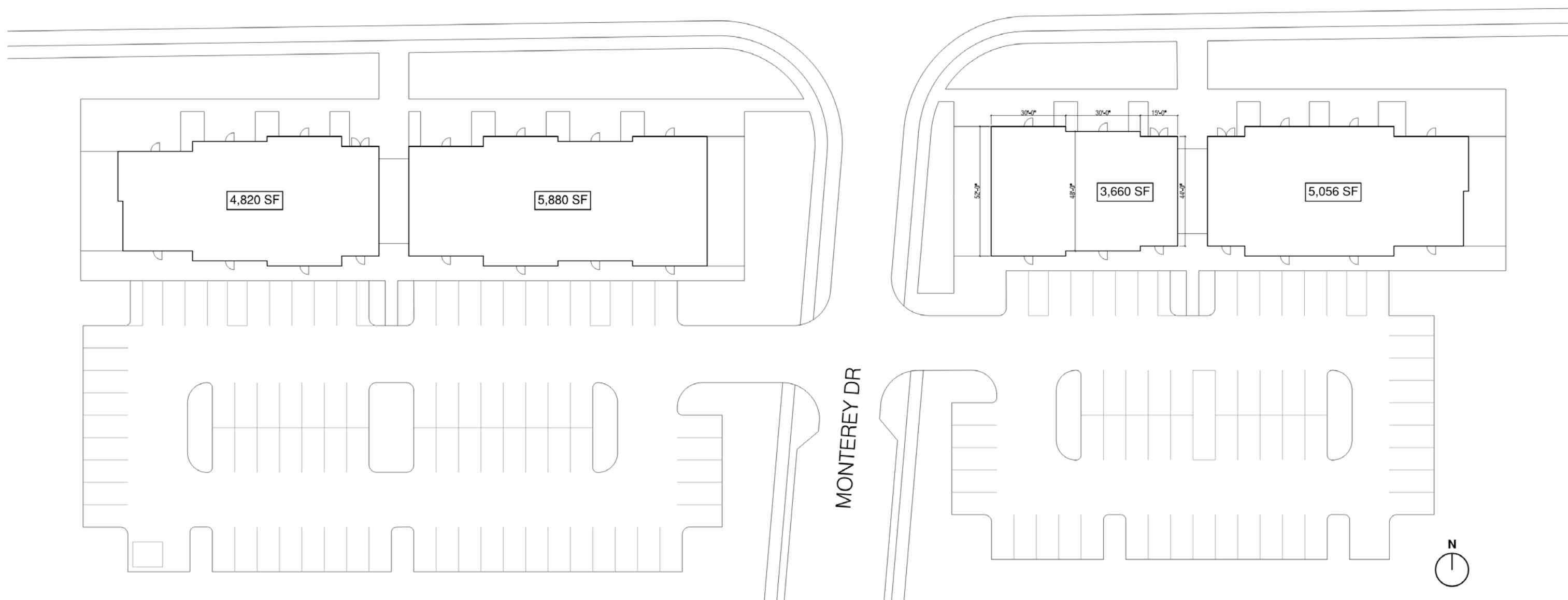



West Elevation (Breezeway)
NTS

West Elevation
NTS

East Elevation
NTS



South Elevation
NTS



North Elevation
NTS

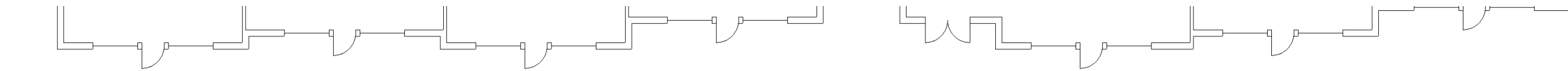



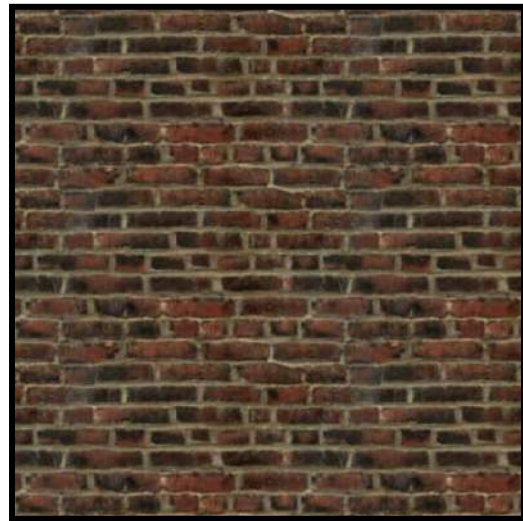

BR-01

MATERIAL: BRICK
 PRODUCT: -
 COLOR: -

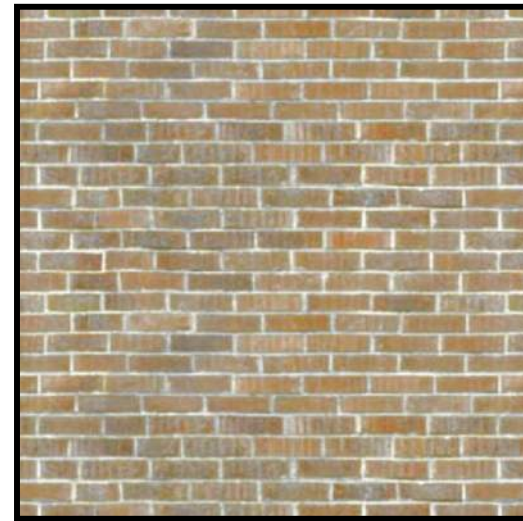

BR-02

MATERIAL: BRICK
 PRODUCT: -
 COLOR: -



FC-01

MATERIAL: FIBER CEMENT SIDING
 PRODUCT: -
 COLOR: BLUE-GREEN



SH-01

MATERIAL: ASPHALT ROOF SHINGLE
 PRODUCT: -
 COLOR: -

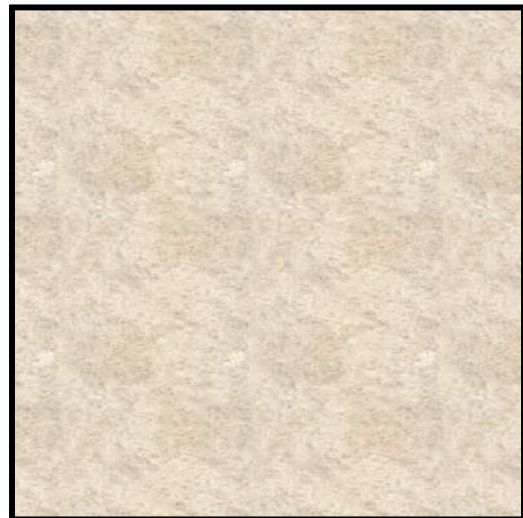

LC-01

MATERIAL: LIMESTONE CAP
 PRODUCT: -
 COLOR: -

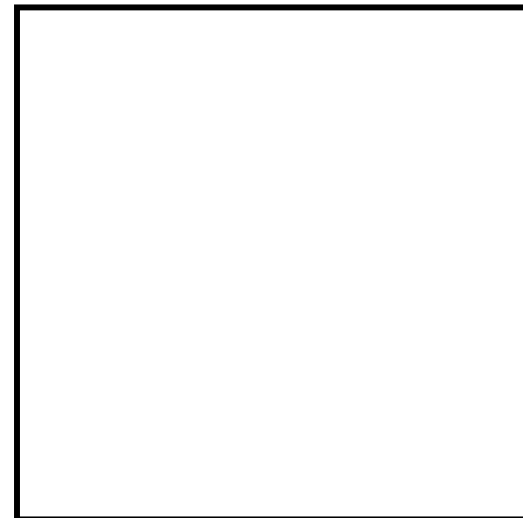

PT-01

MATERIAL: ACCENT PAINT
 PRODUCT: -
 COLOR: WHITE

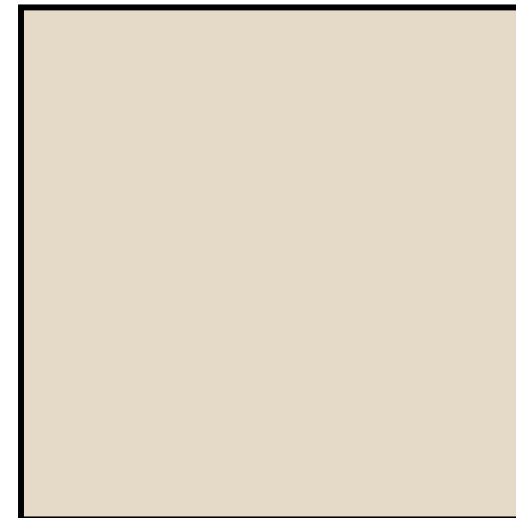

PT-02

MATERIAL: ACCENT PAINT
 PRODUCT: -
 COLOR: BEIGE

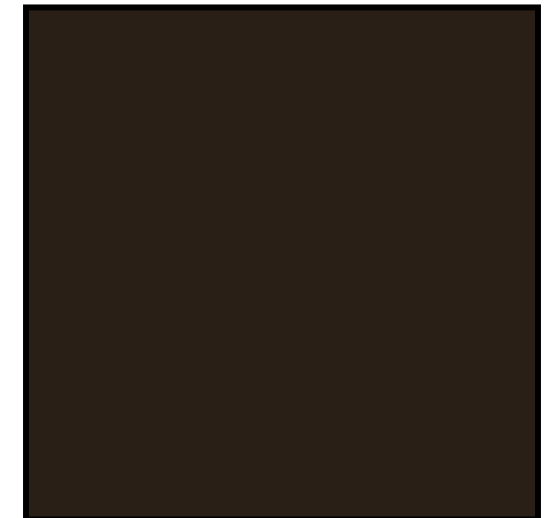

PT-03

MATERIAL: ACCENT PAINT
 PRODUCT: -
 COLOR: DARK BROWN

Proposed Views













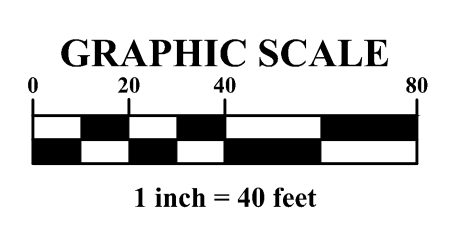
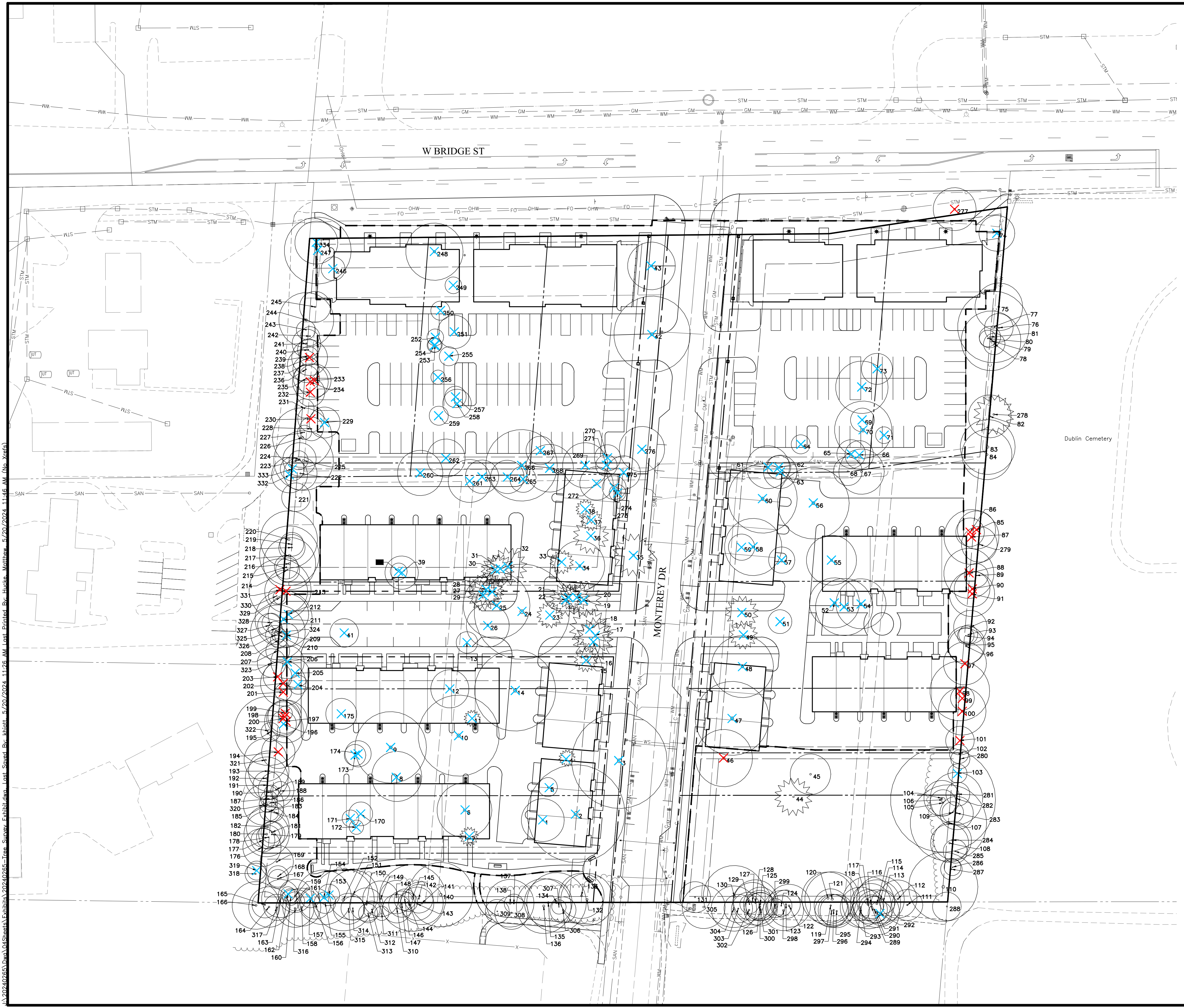

- TREE PRESERVATION LEGEND**
- X TREE TO BE REMOVED AND REPLACED
 - X TREE TO BE REMOVED, EXEMPT FROM REPLACEMENT

- TREE PRESERVATION GENERAL NOTES**
1. THE OWNER SHALL BE RESPONSIBLE FOR THE CONSTRUCTION, ERECTION AND MAINTENANCE OF TEMPORARY FENCING AROUND TREE PRESERVATION AREAS SO THAT ALL PROTECTED TREES SHALL BE PRESERVED. THE FENCING SHALL BE LOCATED A DISTANCE FROM THE TRUNK THAT EQUALS, AT A MINIMUM, THE DISTANCE OF THE CRITICAL ROOT ZONE OR 15 FEET, WHICHEVER IS GREATER. WHERE PHYSICAL SITE CONSTRAINTS DO NOT ALLOW FOR SUCH INSTALLATION, TREE PROTECTION LOCATIONS AND METHODS SHALL BE DETERMINED ON SITE, WITH THE CONSULTATION OF THE CITY OF DUBLIN LANDSCAPE INSPECTOR. CALL 410-4600 FOR TREE FENCING INSPECTION.
 2. FENCING SHALL REMAIN IN PLACE AND BE SECURED IN AN UPRIGHT POSITION DURING THE ENTIRE CONSTRUCTION PERIOD TO PREVENT THE IMPINGEMENT OF CONSTRUCTION VEHICLES, MATERIALS, SPOILS, AND EQUIPMENT INTO OR UPON THE TREE PRESERVATION AREA.
 3. TREE PRESERVATION SIGNS, AVAILABLE FROM THE DIVISION OF LAND USE AND LONG RANGE PLANNING, MUST BE LOCATED ALONG THE FENCING. ANY CHANGE IN PROTECTIVE FENCING MUST BE APPROVED BY THE DIRECTOR OF LAND USE AND LONG RANGE PLANNING.
 4. THE APPROVED TREE PRESERVATION PLAN SHALL BE AVAILABLE ON THE BUILDING SITE BEFORE WORK COMMENCES AND AT ALL TIMES DURING CONSTRUCTION OF THE PROJECT. THE OWNER SHALL BE RESPONSIBLE FOR NOTIFYING ALL CONTRACTORS AND UTILITIES.
 5. DURING ALL PHASES OF CONSTRUCTION, ALL STEPS TO PREVENT THE DESTRUCTION OR DAMAGE TO PROTECTED TREES SHALL BE TAKEN. NO CONSTRUCTION ACTIVITY, MOVEMENT AND/OR PLACEMENT OF EQUIPMENT, VEHICLES, MATERIALS OR SPOILS STORAGE SHALL BE PERMITTED WITHIN THE TREE PRESERVATION AREA. NO EXCESS SOIL, ADDITIONAL FILL, LIQUIDS, OR CONSTRUCTION DEBRIS SHALL BE PLACED WITHIN THE CRITICAL ROOT ZONE OF ALL TREES THAT ARE TO BE PRESERVED.
 6. NO ATTACHMENTS, INCLUDING BUT NOT LIMITED TO ROPES, NAILS, ADVERTISING POSTERS, SIGNS, FENCES, OR WIRES (OTHER THAN THOSE USED FOR BRACING, GUYING OR WRAPPING) SHALL BE ATTACHED TO ANY TREE.
 7. NO GASEOUS LIQUIDS OR SOLID SUBSTANCES WHICH ARE HARMFUL TO TREES SHALL BE PERMITTED WITHIN THE TREE PRESERVATION AREA.
 8. NO FIRE OR HEAT SHALL BE PERMITTED WITHIN THE TREE PRESERVATION AREA.
 9. ALL UTILITIES, INCLUDING SERVICE LINES, SHALL BE INSTALLED IN ACCORDANCE WITH THE TREE PRESERVATION PLAN.

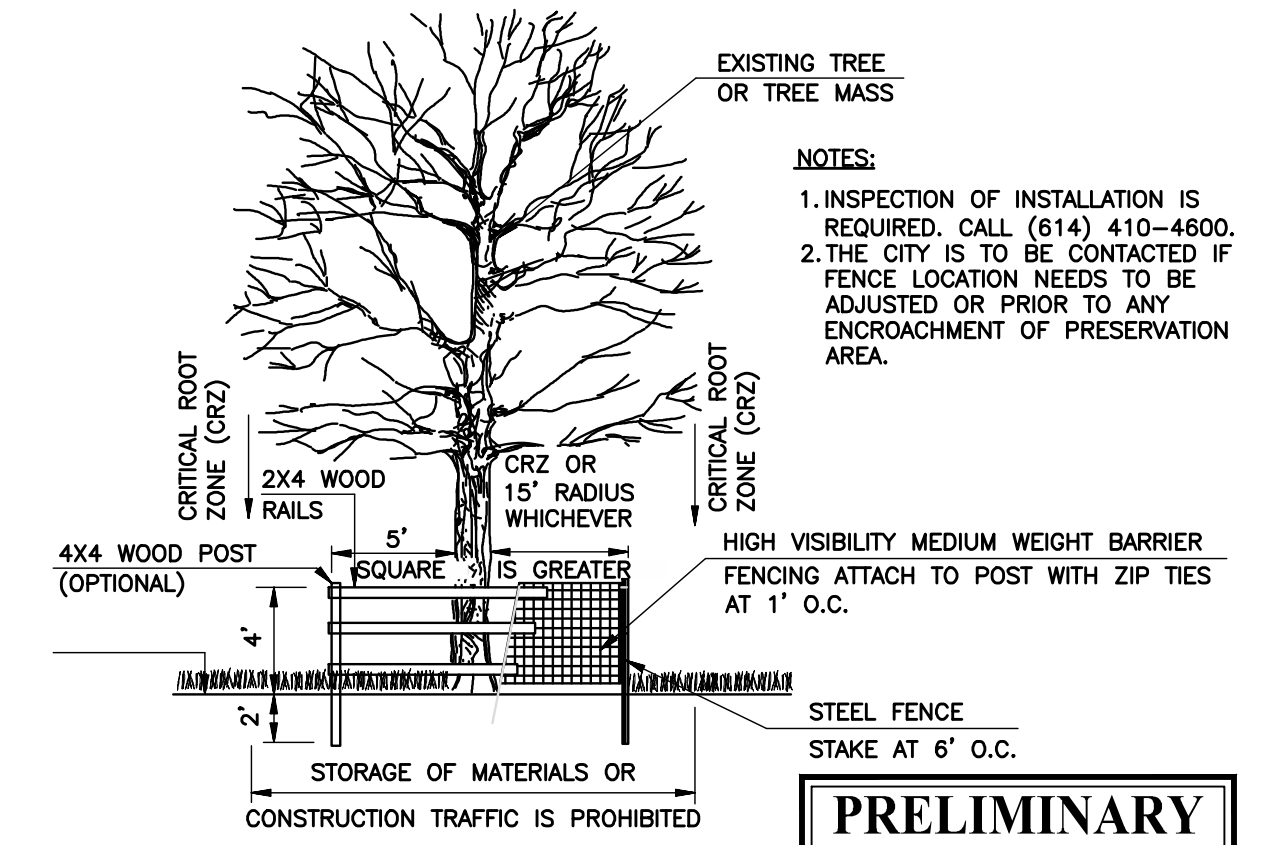

TREE PRESERVATION DETAIL
Not to Scale

PRELIMINARY
NOT TO BE USED FOR CONSTRUCTION

PLAN SET DATE
May 20, 2024

MARK	DATE	DESCRIPTION

CRAWFORD HOYING

CITY OF DUBLIN, FRANKLIN COUNTY, OHIO
FOR
MONTEREY DRIVE REDEVELOPMENT
TREE SURVEY & REPLACEMENT EXHIBIT

DATE
May 20, 2024

SCALE
1" = 40'

JOB NO.
20240265

SHEET
3/11

I:\2024\0265\Drawings\Exhibits\20240265-Tree_Survey_Exhibit.dwg - Tree_Survey_Exhibit.dwg - Tree_Survey_Exhibit.dwg - Tree_Survey_Exhibit.dwg - Tree_Survey_Exhibit.dwg
 Plot Date: 5/20/2024 11:26 AM
 Plot Scale: 1/40
 Plot Size: 11.46 x 11.46
 Plot Title: MONTEREY DRIVE REDEVELOPMENT TREE SURVEY & REPLACEMENT EXHIBIT

ID	Common Name	Scientific Name	DBH (Inches)	No. of Trunks	Condition
1	Black Cherry	Prunus serotina	18	1	Fair
2	American Sycamore	Platanus occidentalis	41	1	Fair
3	Silver Maple	Acer saccharinum	40	1	Good
4	Arborvitae	Thuja sp.	13	2	Good
5	Red Mulberry	Morus rubra	21	3	Good
6	Thornless Honey Locust	Gleditsia triacanthos var. inermis	59	3	Good
7	Arborvitae	Thuja sp.	15	2	Good
8	Red Maple	Acer rubrum	21	1	Good
9	Red Maple	Acer rubrum	30	1	Fair
10	Red Maple	Acer rubrum	34	1	Good
11	Arborvitae	Thuja sp.	7	1	Good
12	Hackberry	Celtis occidentalis	26	2	Good
13	Red Maple	Acer rubrum	9	1	Peor
14	Thornless Honey Locust	Gleditsia triacanthos var. inermis	34	1	Good
15	Arborvitae	Thuja sp.	17	2	Fair
16	Eastern White Pine	Pinus strobus	17	1	Good
17	Eastern White Pine	Pinus strobus	15	1	Good
18	Eastern White Pine	Pinus strobus	17	1	Good
19	Eastern White Pine	Pinus strobus	15	1	Good
20	Eastern White Pine	Pinus strobus	11	1	Good
21	Eastern White Pine	Pinus strobus	10	1	Good
22	Eastern White Pine	Pinus strobus	14	1	Good
23	Eastern White Pine	Pinus strobus	11	1	Good
24	Silver Maple	Acer saccharinum	40	1	Good
25	Red Maple	Acer rubrum	28	1	Fair
26	Red Maple	Acer rubrum	51	3	Good
27	Eastern White Pine	Pinus strobus	10	1	Good
28	Eastern White Pine	Pinus strobus	14	1	Good
29	Eastern White Pine	Pinus strobus	13	1	Good
30	Eastern White Pine	Pinus strobus	12	1	Good
31	Eastern White Pine	Pinus strobus	12	1	Good
32	Eastern White Pine	Pinus strobus	16	1	Good
33	Eastern White Pine	Pinus strobus	10	1	Good
34	Green Ash	Fraxinus pennsylvanica	21	1	Poor
35	Eastern White Pine	Pinus strobus	18	1	Good
36	Eastern White Pine	Pinus strobus	15	1	Good
37	Eastern White Pine	Pinus strobus	9	1	Peor
38	Arborvitae	Thuja sp.	38	5	Good
39	Hackberry	Celtis occidentalis	51	6	Good
40	Black Cherry	Prunus serotina	7	1	Good
41	Hackberry	Celtis occidentalis	12	1	Good
42	Chinese Elm	Ulmus parvifolia	32	1	Good
43	Chinese Elm	Ulmus parvifolia	49	3	Good
44	Norway Spruce	Picea abies	16	1	Good
45	Black Walnut	Juglans nigra	17	1	Good
46	Black Walnut	Juglans nigra	24	1	Good
47	American Sycamore	Platanus occidentalis	31	1	Good
48	Black Walnut	Juglans nigra	41	2	Good
49	Eastern White Pine	Pinus strobus	12	1	Good
50	Eastern White Pine	Pinus strobus	14	1	Good
51	Japanese Yew	Taxus cuspidata	48	6	Good
52	Hackberry	Celtis occidentalis	21	1	Good
53	Black Cherry	Prunus serotina	24	1	Good
54	Hackberry	Celtis occidentalis	21	1	Good
55	Red Mulberry	Morus rubra	41	2	Fair
56	Black Walnut	Juglans nigra	48	2	Good
57	Black Cherry	Prunus serotina	11	1	Good
58	Hackberry	Celtis occidentalis	24	1	Good
59	Hackberry	Celtis occidentalis	11	1	Good
60	American Sycamore	Platanus occidentalis	29	1	Good
61	Black Walnut	Juglans nigra	18	1	Good
62	Black Walnut	Juglans nigra	10	1	Good
63	Red Mulberry	Morus rubra	14	1	Peor
64	Box Elder	Acer negundo	8	1	Good
65	Black Cherry	Prunus serotina	12	1	Good
66	Red Mulberry	Morus rubra	12	1	Peor
67	Hackberry	Celtis occidentalis	19	1	Fair
68	Hackberry	Celtis occidentalis	12	1	Good
69	Hackberry	Celtis occidentalis	10	1	Good
70	Eastern Cottonwood	Populus deltoides	47	2	Poor
71	Black Walnut	Juglans nigra	7	1	Fair
72	Red Mulberry	Morus rubra	41	2	Fair
73	Black Walnut	Juglans nigra	13	1	Good
74	Box Elder	Acer negundo	48	4	Fair
75	Hackberry	Celtis occidentalis	20	1	Good
76	Hackberry	Celtis occidentalis	12	1	Good
77	Hackberry	Celtis occidentalis	30	1	Good
78	Hackberry	Celtis occidentalis	9	1	Good
79	Slippery Elm	Ulmus rubra	25	1	Good
80	Slippery Elm	Ulmus rubra	7	1	Good
81	Slippery Elm	Ulmus rubra	9	1	Good
82	Black Cherry	Prunus serotina	18	1	Good
83	Hackberry	Celtis occidentalis	23	1	Good
84	Hackberry	Celtis occidentalis	21	1	Good
85	Sugar Maple	Acer saccharum	16	1	Good
86	Hackberry	Celtis occidentalis	12	1	Good
87	Hackberry	Celtis occidentalis	33	2	Good
88	Sugar Maple	Acer saccharum	21	1	Good
89	Sugar Maple	Acer saccharum	10	1	Good
90	Hackberry	Celtis occidentalis	15	1	Good
91	Hackberry	Celtis occidentalis	19	1	Good
92	Hackberry	Celtis occidentalis	14	1	Good
93	Sugar Maple	Acer saccharum	8	1	Good
94	Sugar Maple	Acer saccharum	7	1	Good
95	Sugar Maple	Acer saccharum	16	1	Good
96	Sugar Maple	Acer saccharum	15	1	Good
97	Black Walnut	Juglans nigra	18	1	Good
98	Black Walnut	Juglans nigra	25	1	Good
99	Hackberry	Celtis occidentalis	10	1	Good
100	Hackberry	Celtis occidentalis	20	1	Good
101	Hackberry	Celtis occidentalis	12	1	Good
102	Black Walnut	Juglans nigra	8	1	Good
103	Green Ash	Fraxinus pennsylvanica	8	1	Peor
104	Hackberry	Celtis occidentalis	15	1	Good
105	Hackberry	Celtis occidentalis	11	1	Good
106	Black Walnut	Juglans nigra	44	1	Fair
107	Black Walnut	Juglans nigra	32	1	Good
108	Black Walnut	Juglans nigra	29	2	Good
109	Hackberry	Celtis occidentalis	9	1	Good
110	Black Walnut	Juglans nigra	29	1	Good
111	Hackberry	Celtis occidentalis	13	1	Good
112	Hackberry	Celtis occidentalis	16	1	Good
113	Hackberry	Celtis occidentalis	10	1	Good

ID	Common Name	Scientific Name	DBH (Inches)	No. of Trunks	Condition
114	Hackberry	Celtis occidentalis	36	2	Good
115	Hackberry	Celtis occidentalis	20	1	Good
116	Hackberry	Celtis occidentalis	17	1	Good
117	Hackberry	Celtis occidentalis	22	1	Good
118	Hackberry	Celtis occidentalis	13	1	Good
119	Hackberry	Celtis occidentalis	14	1	Good
120	Hackberry	Celtis occidentalis	22	1	Good
121	Hackberry	Celtis occidentalis	23	1	Good
122	Hackberry	Celtis occidentalis	32	2	Good
123	Hackberry	Celtis occidentalis	12	1	Good
124	Hackberry	Celtis occidentalis	9	1	Good
125	Hackberry	Celtis occidentalis	14	1	Good
126	Hackberry	Celtis occidentalis	12	1	Good
127	Hackberry	Celtis occidentalis	16	1	Good
128	Hackberry	Celtis occidentalis	19	1	Good
129	Hackberry	Celtis occidentalis	8	1	Good
130	Hackberry	Celtis occidentalis	26	1	Good
131	Hackberry	Celtis occidentalis	13	1	Good
132	Hackberry	Celtis occidentalis	22	1	Good
133	Hackberry	Celtis occidentalis	19	1	Good
134	Hackberry	Celtis occidentalis	25	1	Good
135	Hackberry	Celtis occidentalis	20	1	Good
136	Hackberry	Celtis occidentalis	23	1	Good
137	Hackberry	Celtis occidentalis	8	1	Good
138	Hackberry	Celtis occidentalis	20	1	Fair
139	Hackberry	Celtis occidentalis	19	1	Fair
140	Black Walnut	Juglans nigra	27	1	Good
141	Thornless Honey Locust	Gleditsia triacanthos var. inermis	18	1	Good
142	Hackberry	Celtis occidentalis	12	1	Good
143	Hackberry	Celtis occidentalis	14	1	Good
144	Hackberry	Celtis occidentalis	8	1	Good
145	Thornless Honey Locust	Gleditsia triacanthos var. inermis	66	3	Good
146	Hackberry	Celtis occidentalis	9	1	Good
147	Hackberry	Celtis occidentalis	20	2	Good
148	Hackberry	Celtis occidentalis	14	1	Good
149	Hackberry	Celtis occidentalis	15	1	Good
150	Hackberry	Celtis occidentalis	14	1	Good
151	Hackberry	Celtis occidentalis	21	1	Good
152	Black Cherry	Prunus serotina	26	1	Fair
153	Green Ash	Fraxinus pennsylvanica	9	1	Peor
154	Green Ash	Fraxinus pennsylvanica	23	1	Peor
155	Hackberry	Celtis occidentalis	9	1	Good
156	Hackberry	Celtis occidentalis	13	1	Good
157	Green Ash	Fraxinus pennsylvanica	8	1	Peor
158	Hackberry	Celtis occidentalis	31	3	Good
159	Hackberry	Celtis occidentalis	14	1	Good
160	Hackberry	Celtis occidentalis	7	1	Good
161	Chinkapin Oak	Quercus muehlenbergii	8	1	Good
162	Green Ash	Fraxinus pennsylvanica	6	1	Peor
163	Hackberry	Celtis occidentalis	16	1	Good
164	Hackberry	Celtis occidentalis	23	2	Good
165	Hackberry	Celtis occidentalis	11	1	Good
166	Hackberry	Celtis occidentalis	20	1	Good
167	Hackberry	Celtis occidentalis	8	1	Good
168	Hackberry	Celtis occidentalis	9	1	Good
169	Hackberry	Celtis occidentalis	14	1	Good
170	Black Walnut	Juglans nigra	10	1	Good
171	Black Walnut	Juglans nigra	7	1	Good
172	Red Mulberry	Morus rubra	6	1	Good
173	Red Mulberry	Morus rubra	17	2	Fair
174	Red Mulberry	Morus rubra	11	1	Fair
175	Hackberry	Celtis occidentalis	62	6	Good
176	Hackberry	Celtis occidentalis	16	1	Good
177	Hackberry	Celtis occidentalis	10	1	Good
178	Hackberry	Celtis occidentalis	10	1	Good
179	Hackberry	Celtis occidentalis	19	2	Good
180	Hackberry	Celtis occidentalis	28	2	Good
181	Hackberry	Celtis occidentalis	9	1	Good
182	Hackberry	Celtis occidentalis	18	1	Good
183	Hackberry	Celtis occidentalis	8	1	Good
184	Hackberry	Celtis occidentalis	8	1	Good
185	Hackberry	Celtis occidentalis	7	1	Good
186	Hackberry	Celtis occidentalis	6	1	Fair
187	Hackberry	Celtis occidentalis	7	1	Good
188	Hackberry	Celtis occidentalis	8	1	Good
189	Hackberry	Celtis occidentalis	15	1	Good
190	Hackberry	Celtis occidentalis	6	1	Good
191	Hackberry	Celtis occidentalis	12	1	Good
192	Hackberry	Celtis occidentalis	18	1	Good
193	Hackberry	Celtis occidentalis	57	4	Good
194	Sugar Maple	Acer saccharum	14	1	Good
195	Hackberry	Celtis occidentalis	8	1	Good
196	Hackberry	Celtis occidentalis	11	1	Peor
197	Hackberry	Celtis occidentalis	18	1	Fair
198	Hackberry	Celtis occidentalis	14	1	Fair
199	Hackberry	Celtis occidentalis	6	1	Fair
200	Hackberry	Celtis occidentalis	14	1	Fair
201	Hackberry	Celtis occidentalis	7	1	Good
202	Hackberry	Celtis occidentalis	33	2	Good
203	Hackberry	Celtis occidentalis	22	2	Good
204	Red Mulberry	Morus rubra	8	1	Peor
205	Black Walnut	Juglans nigra	12	1	Good
206	Hackberry	Celtis occidentalis	14	1	Good
207	Hackberry	Celtis occidentalis	18	2	Good
208	Hackberry	Celtis occidentalis	14	2	Good
209	Hackberry	Celtis occidentalis	10	1	Good
210	Hackberry	Celtis occidentalis	6	1	Good
211	Hackberry	Celtis occidentalis	24	1	Good
212	Hackberry	Celtis occidentalis	17	1	Good
213	Hackberry	Celtis occidentalis	18	1	Good
214	Hackberry	Celtis occidentalis	10	1	Good
215	Hackberry	Celtis occidentalis	10	1	Good
216	Hackberry	Celtis occidentalis	22	1	Good
217	Hackberry	Celtis occidentalis	25	1	Good
218	Hackberry	Celtis occidentalis	11	1	Good
219	Hackberry	Celtis occidentalis	10	1	Good
220	Hackberry	Celtis occidentalis	24	1	Good
221	Thornless Honey Locust	Gleditsia triacanthos var. inermis	12	1	Good
222	Hackberry	Celtis occidentalis	14	1	Good
223	Hackberry	Celtis occidentalis	8	1	Fair
224	Hackberry	Celtis occidentalis	14	1	Good
225	Hackberry	Celtis occidentalis	25	1	Good
226	Hackberry	Celtis occidentalis	25	1	Good

ID	Common Name	Scientific Name	DBH (Inches)	No. of Trunks	Condition
227	Hackberry	Celtis occidentalis	6	1	Good
228	Hackberry	Celtis occidentalis	10	1	Good
229	Red Mulberry	Morus rubra	13	1	Good
230	Hackberry	Celtis occidentalis	11	1	Good
231	Hackberry	Celtis occidentalis	8	1	Fair
232	Hackberry	Celtis occidentalis	12	1	Good
233	Hackberry	Celtis occidentalis	14	1	Good
234	Hackberry	Celtis occidentalis	15	1	Good
235	Hackberry	Celtis occidentalis	11	1	Fair
236	Hackberry	Celtis occidentalis	11	1	Good
237	Hackberry	Celtis occidentalis	25	2	Good
238	Hackberry	Celtis occidentalis	15	1	Good
239	Hackberry	Celtis occidentalis	8	1	Good
240	Hackberry	Celtis occidentalis	9	1	Good
241	Hackberry	Celtis occidentalis	12	1	Fair
242	Black Walnut	Juglans nigra	8	1	Good
243	Hackberry	Celtis occidentalis	8	1	Good
244	Hackberry	Celtis occidentalis	23	1	Good
245	Hackberry	Celtis occidentalis	13	1	Good
246	Red Mulberry	Morus rubra	10	1	Good
247	Hackberry	Celtis occidentalis	28	1	Good
248	Green Ash	Fraxinus pennsylvanica	24	1	Fair
249	Wild Crabapple	Malus coronaria	19	3	Good
250	Red Mulberry	Morus rubra	15	2	Fair
251	Hackberry	Celtis occidentalis			

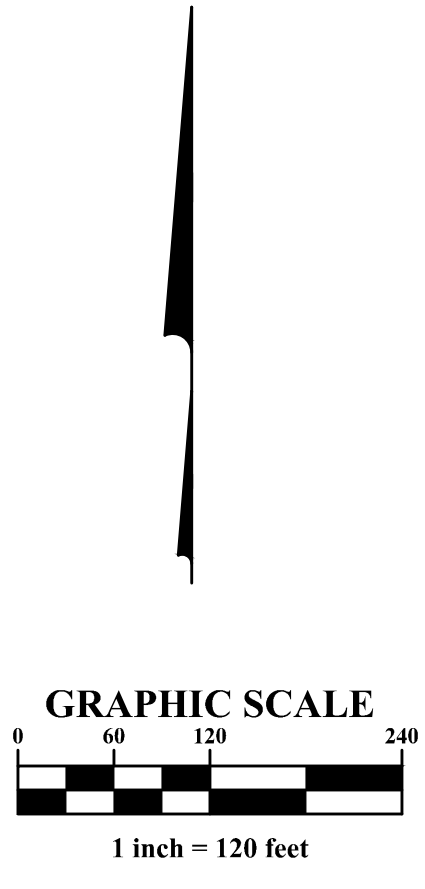
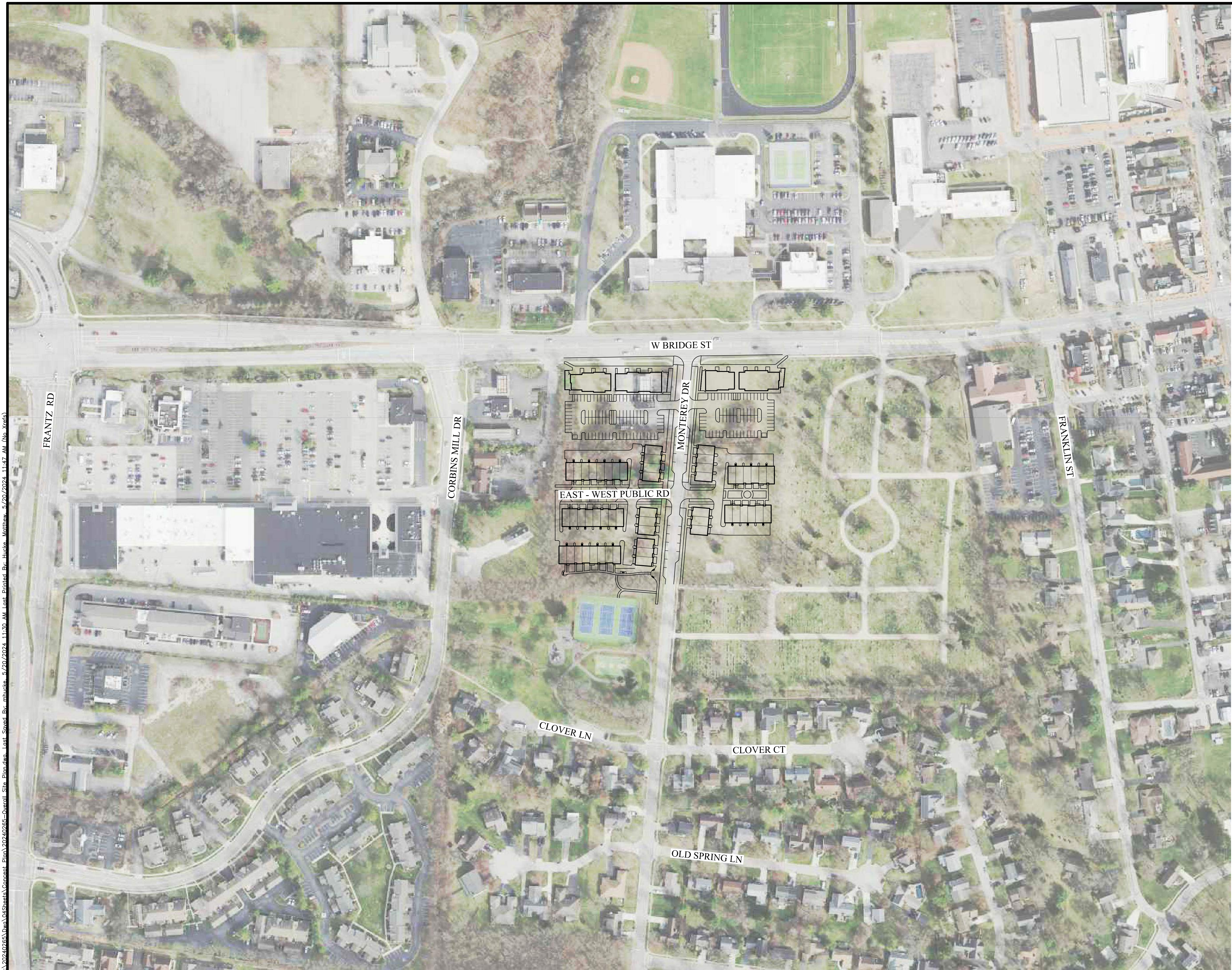

I:\2024\265\Drawings\Sheets\Concept\Plan\20240265-Overall_Site_Plan.dwg - Lst_Saved By: mluicke_5/20/2024 11:30 AM Last Printed By: Buckle_Matthew_5/20/2024 11:47 AM (No Xrefs)

MARK	DATE	DESCRIPTION	REVISIONS

CRAWFORD HOYING

CITY OF DUBLIN, FRANKLIN COUNTY, OHIO
 FOR
**MONTEREY DRIVE
 REDEVELOPMENT**
 OVERALL SITE PLAN

EMHT
 Earth & Mechanical
 Engineers & Surveyors & Planners & Scientists
 5500 New Albany Road, Columbus, OH 43054
 Phone: 614.775.4500 Fax: 614.775.4501
 emht.com

DATE
 May 20, 2024

SCALE
 1" = 120'

JOB NO.
 20240265

SHEET
5/11

PRELIMINARY
 NOT TO BE USED FOR
 CONSTRUCTION
 PLAN SET DATE
 May 20, 2024

I:\2024\265\Drawings\Conceptual\Plan\20240265_SitePlan.dwg - Saved By: atoutman_5/17/2024 4:43 PM - Last Printed By: Huckle, Matthew_5/20/2024 11:47 AM (No Xrefs)

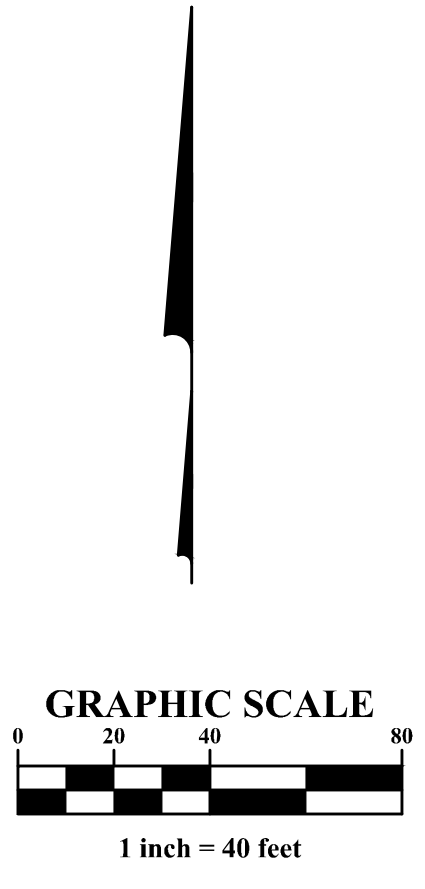
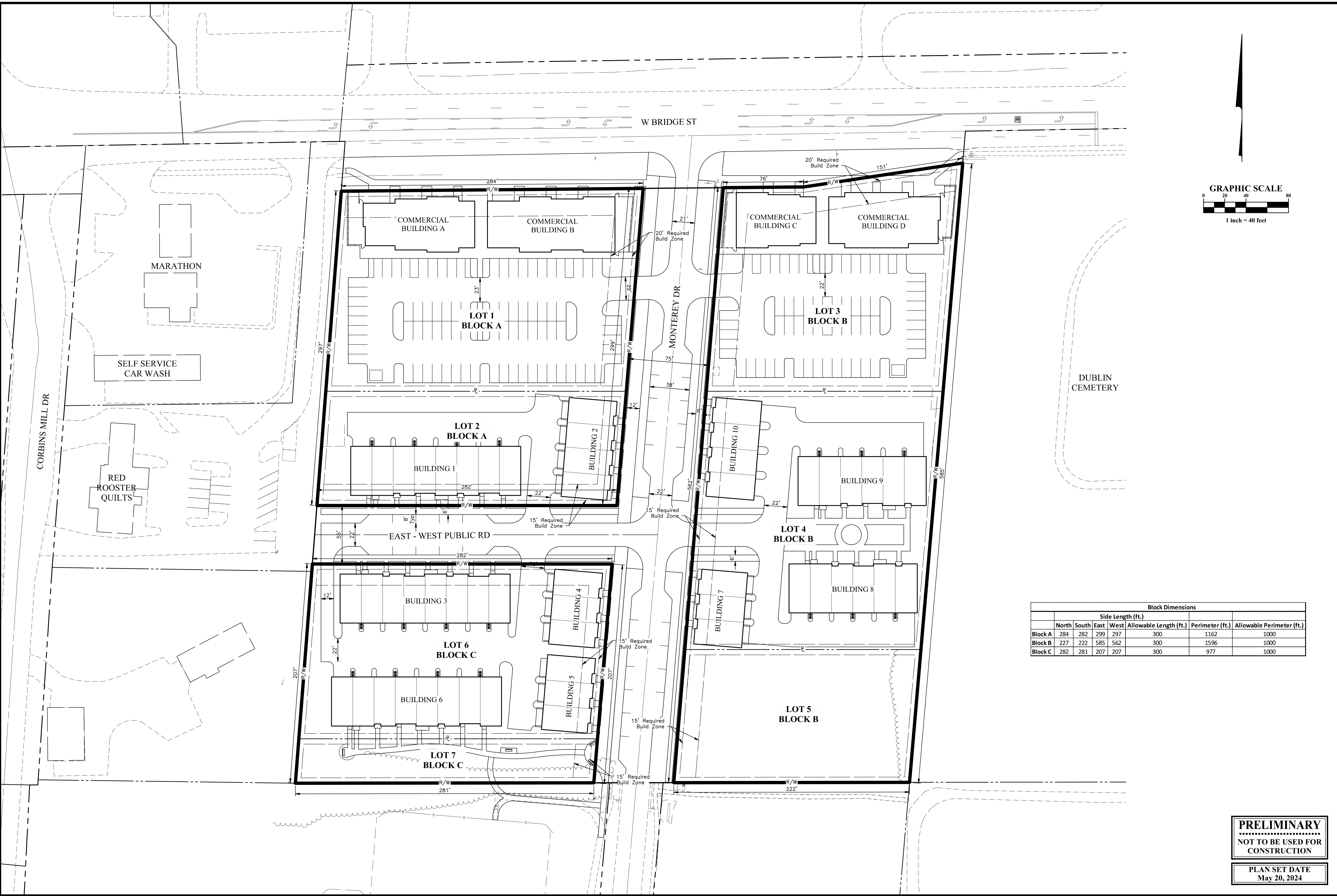

	Block Dimensions						
	North	South	East	West	Allowable Length (ft.)	Perimeter (ft.)	Allowable Perimeter (ft.)
Block A	284	282	299	297	300	1162	1000
Block B	227	222	585	562	300	1596	1000
Block C	282	281	207	207	300	977	1000

MARK	DATE	DESCRIPTION

CRAWFORD HOYING

CITY OF DUBLIN, FRANKLIN COUNTY, OHIO
 FOR
MONTEREY DRIVE REDEVELOPMENT
 CONCEPT PLAN
 SITE PLAN

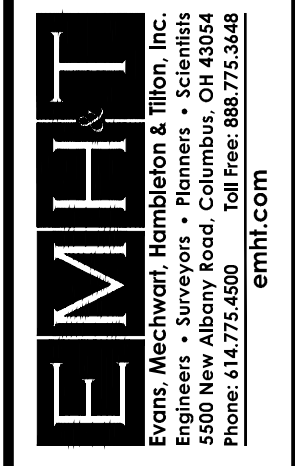

DATE
May 20, 2024

SCALE
1" = 40'

JOB NO.
20240265

SHEET
6/11

PRELIMINARY
 NOT TO BE USED FOR
 CONSTRUCTION

PLAN SET DATE
 May 20, 2024

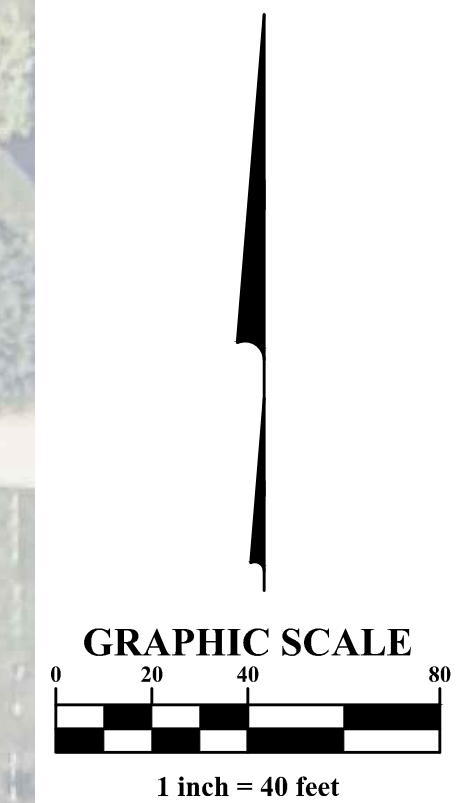

PRELIMINARY
 NOT TO BE USED FOR
 CONSTRUCTION

PLAN SET DATE
 May 20, 2024

MARK	DATE	DESCRIPTION

CRAWFORD HOYING

CITY OF DUBLIN, FRANKLIN COUNTY, OHIO
 FOR
**MONTEREY DRIVE
 REDEVELOPMENT**
 ILLUSTRATIVE SITE PLAN



DATE
 May 20, 2024

SCALE
 1" = 40'

JOB NO.
 20240265

SHEET
 7/11

I:\2024\265\265\DWG\15-RENDER-1.dwg - Last Saved By: bmozenix - 5/20/2024 10:45 AM - Last Printed By: hucke - Matthew - 5/20/2024 11:47 AM (No Xrefs)

J:\20240265\DWG\04Sheets\Concept Plan\20240265- Grading and Utility Plan.dwg, Last Saved By: otoutman, 5/20/2024 9:29 AM, Last Printed By: Huckle, Matthew, 5/20/2024 11:47 AM (No Xref)

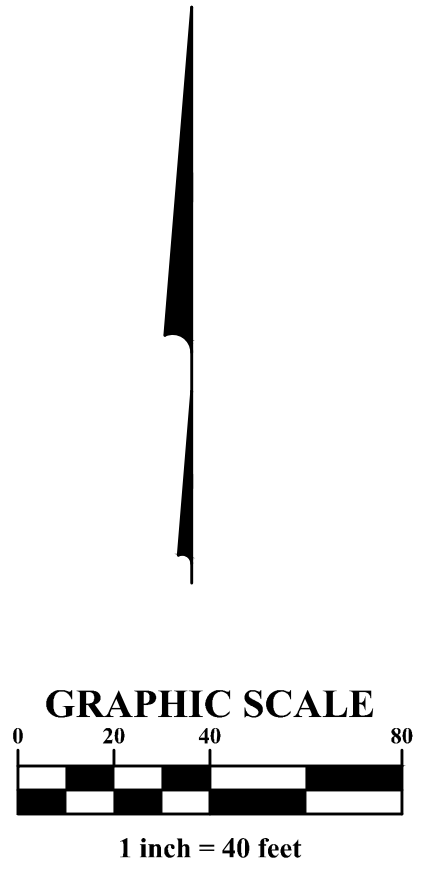

MARK	DATE	DESCRIPTION

CRAWFORD HOYING

CITY OF DUBLIN, FRANKLIN COUNTY, OHIO
 FOR
**MONTEREY DRIVE
 REDEVELOPMENT**
 CONCEPT UTILITY PLAN

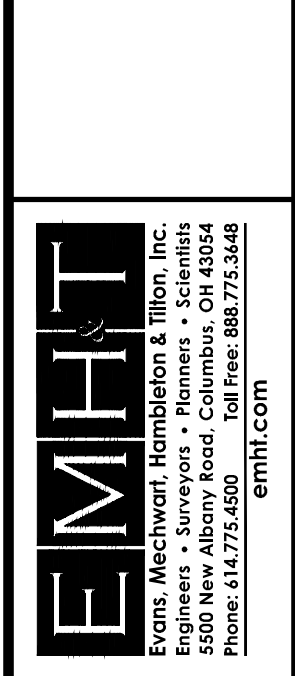

DATE
 May 20, 2024

SCALE
 1" = 40'

JOB NO.
 20240265

SHEET
8/11

PRELIMINARY
 NOT TO BE USED FOR
 CONSTRUCTION

PLAN SET DATE
 May 20, 2024

J:\20240265\DWG\04Sheets\Concept Plan\20240265 - Emergency Vehicle Access Plan.dwg, Last Saved By: otoutman, 5/20/2024 9:55 AM Last Printed By: Huckle, Matthew, 5/20/2024 11:48 AM (No Xrefs)

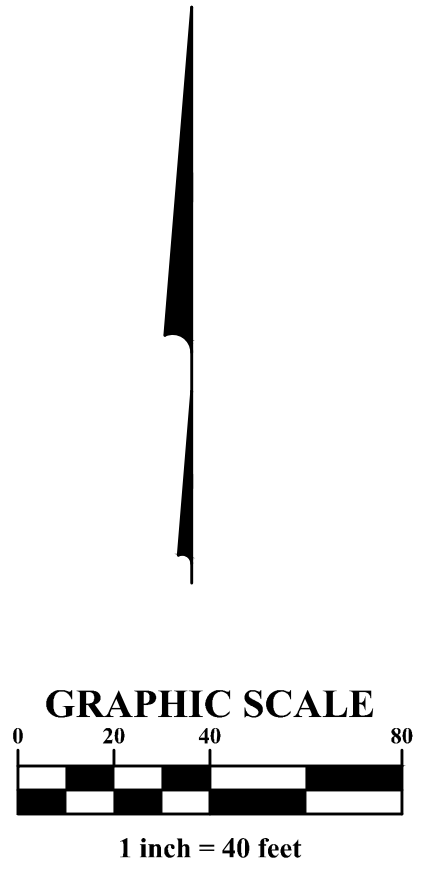
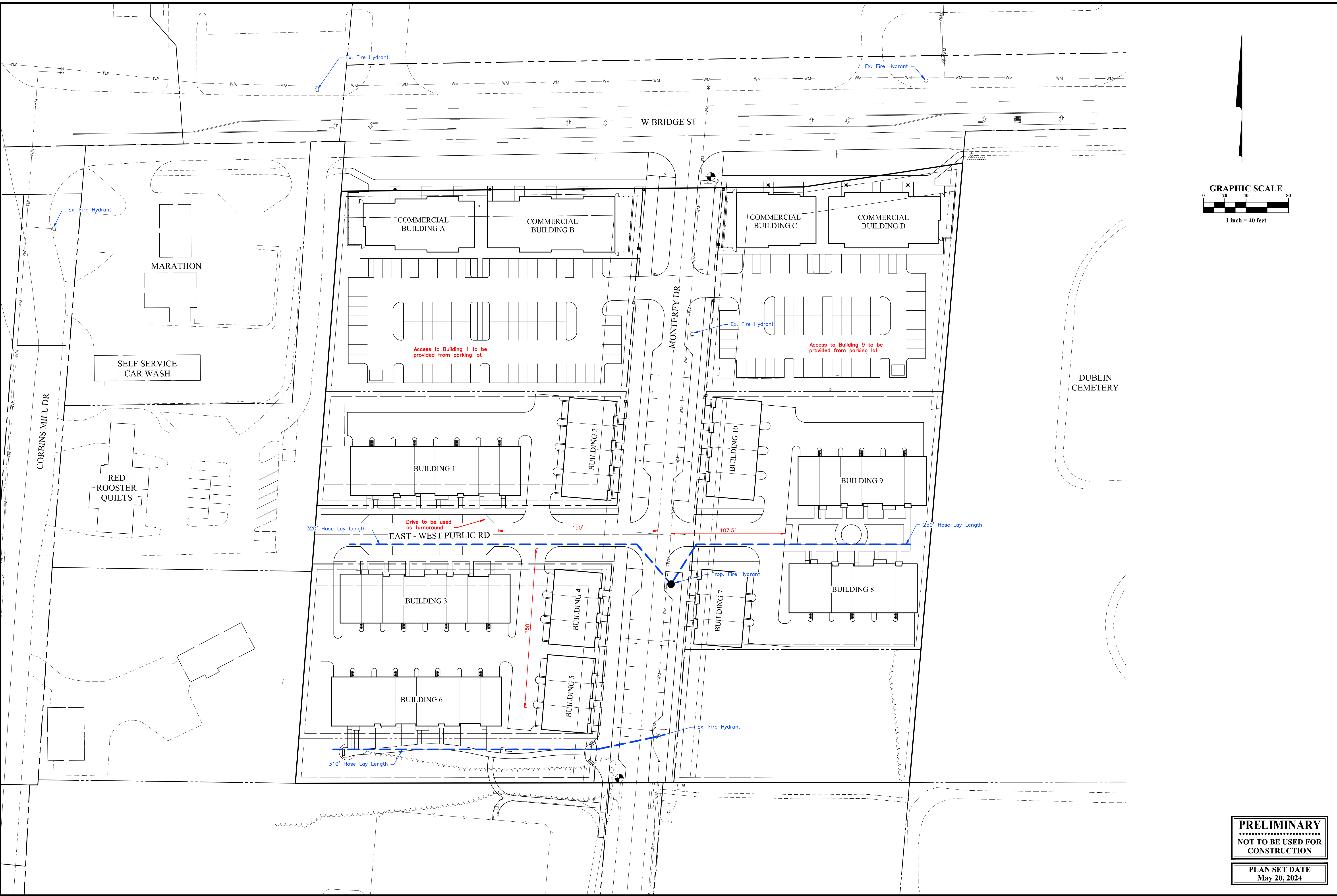

MARK	DATE	DESCRIPTION

CRAWFORD HOYING

CITY OF DUBLIN, FRANKLIN COUNTY, OHIO
 FOR
**MONTEREY DRIVE
 REDEVELOPMENT**
 EMERGENCY VEHICLE ACCESS PLAN

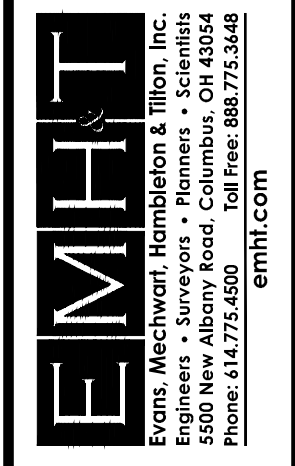

DATE
 May 20, 2024

SCALE
 1" = 40'

JOB NO.
 20240265

SHEET
 9/11

PRELIMINARY
 NOT TO BE USED FOR
 CONSTRUCTION

PLAN SET DATE
 May 20, 2024

X:\2024\265\Drawings\45\Sheets\Concept - Plan\20240265 - Open Area Plan.dwg - Last Saved By: crouman_5/20/2024 10:14 AM - Last Printed By: hucke_mattew_5/20/2024 11:48 AM (No Xrefs)

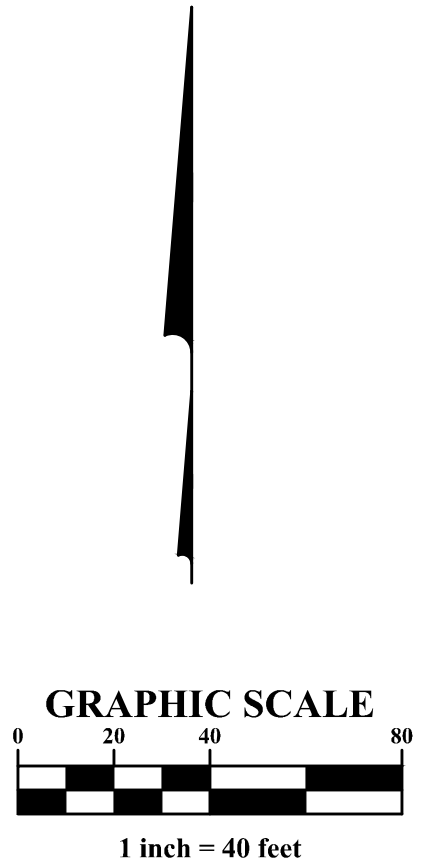

OPEN SPACE LEGEND

- Other Open Space
- Public Open Space

OPEN SPACE CALCULATIONS

Residential Required Area:	53 Units x 200 SF/Unit = 10,600 SF (0.24 Ac.)
Residential Provided Area:	0.25 Ac
Commercial Required Area:	1 SF/ 50 SF 19416 SF/ 50 SF = 388 SF
Total Required Open Space Area:	10988 SF (0.25 Ac.)
Public Open Space Provided:	0.27 Ac
Private Open Space Provided:	0.10 Ac (For Reference Only)
Other Open Space Provided:	0.64 Cemetery Expansion (For Reference Only)

MARK	DATE	DESCRIPTION

CRAWFORD HOYING
FOR
**MONTEREY DRIVE
REDEVELOPMENT**
OPEN AREA PLAN

CITY OF DUBLIN, FRANKLIN COUNTY, OHIO

EMHT
 ERIC M. HAYES, INC.
 ENGINEERS • SURVEYORS • PLANNERS • SCIENTISTS
 5500 New Albany Road, Columbus, OH 43054
 Phone: 614.775.4500 Fax: 614.775.4501
 emht.com

DATE
May 20, 2024

SCALE
1" = 40'

JOB NO.
20240265

SHEET
10/11

PRELIMINARY
 NOT TO BE USED FOR
 CONSTRUCTION

PLAN SET DATE
May 20, 2024

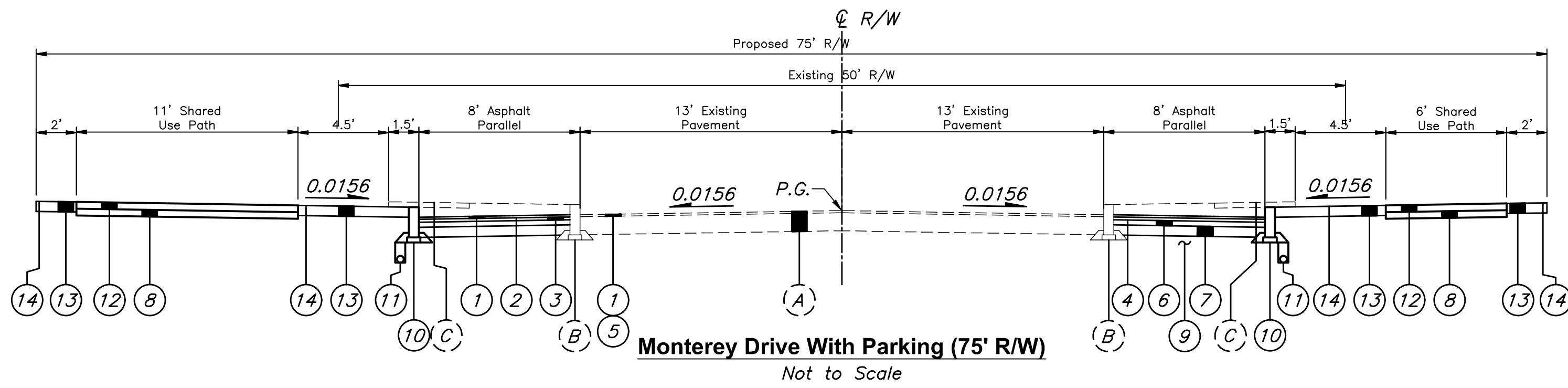

Monterey Drive With Parking (75' R/W)
Not to Scale

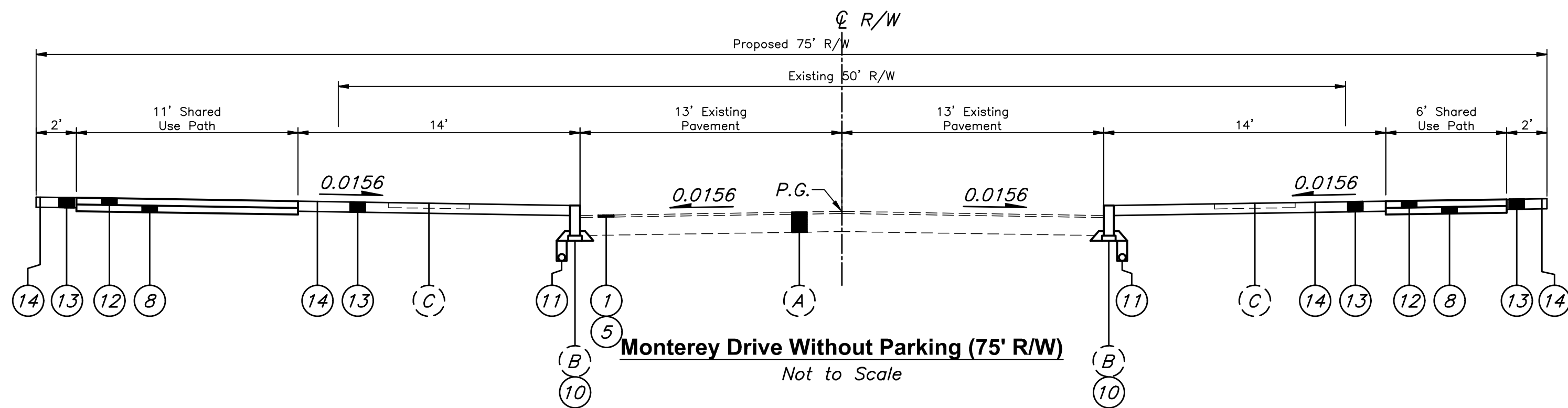

Monterey Drive Without Parking (75' R/W)
Not to Scale

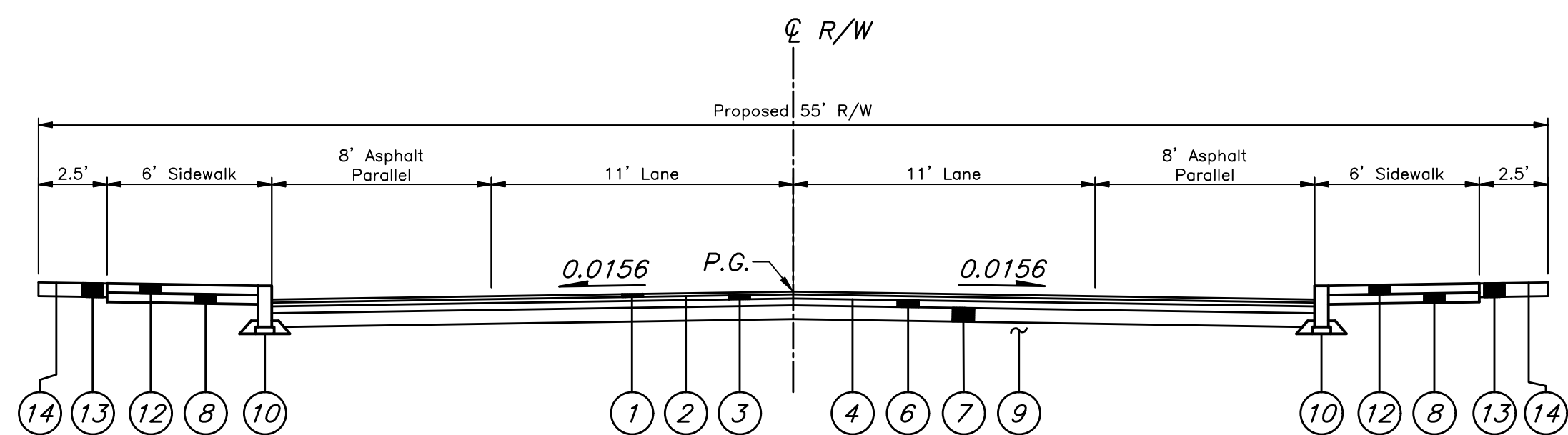

East-West Public Street With Parking (55' R/W)
Not to Scale

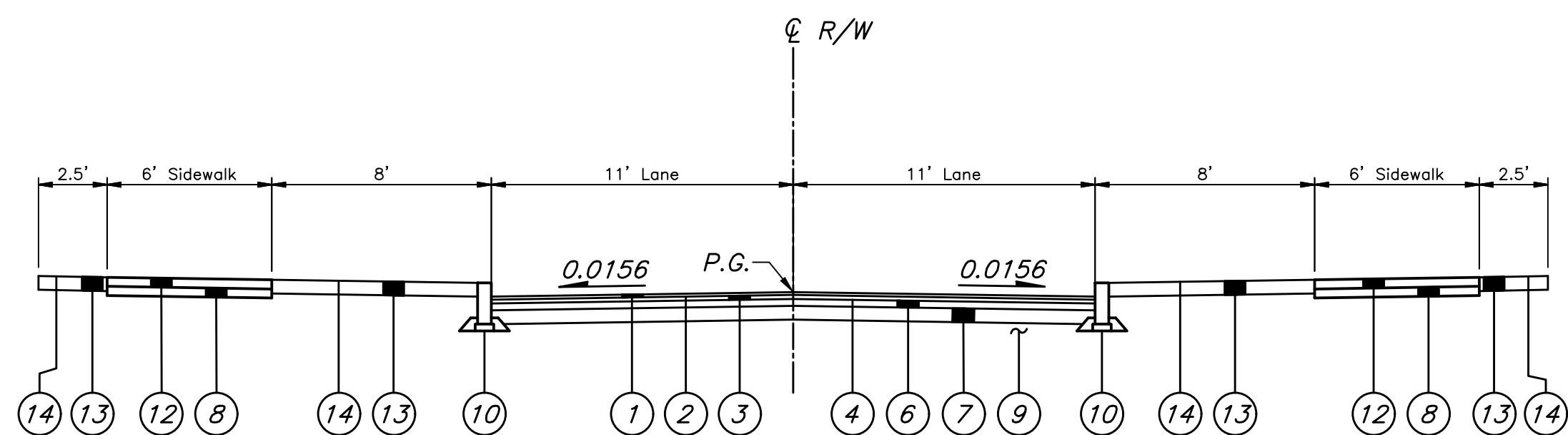

East-West Public Street Without Parking (55' R/W)
Not to Scale

EXISTING PAVEMENT LEGEND

- (A) Existing Pavement To Remain
- (B) Existing Curb & Gutter To Be Removed
- (C) Existing Sidewalk To Be Removed

LEGEND

- 1 Item 448 - 1.25" Asphalt Concrete Surface Course (Medium Traffic), PG64-22
- 2 Item 407 - NTSS-1HM Trackless Tack Coat for Intermediate Course (0.06 Gal./Sq. Yd.)
- 3 Item 448 - 1.75" Asphalt Concrete Intermediate Course (Medium Traffic), PG64-22
- 4 Item 407 - NTSS-1HM Trackless Tack Coat (0.08 Gal./Sq. Yd.)
- 5 Item 254 - Pavement Planing
- 6 Item 301 - 6" Asphalt Concrete Base, PG64-22
- 7 Item 304 - 6" Aggregate Base
- 8 Item 304 - 4" Aggregate Base
- 9 Item 204 - Subgrade Compaction and Proof Rolling
- 10 Item 609 - Straight 18" Curb
- 11 Item 605 - 4" Pipe Underdrain
- 12 Item 608 - 4" Concrete Walk
- 13 Item 659 - Topsoil (T=6")
- 14 Item 659 - Seeding & Mulching

MARK	DATE	DESCRIPTION

CRAWFORD HOYING

CITY OF DUBLIN, FRANKLIN COUNTY, OHIO
CONCEPT PLAN

**FOR
MONTEREY DRIVE
REDEVELOPMENT
TYPICAL SECTIONS**

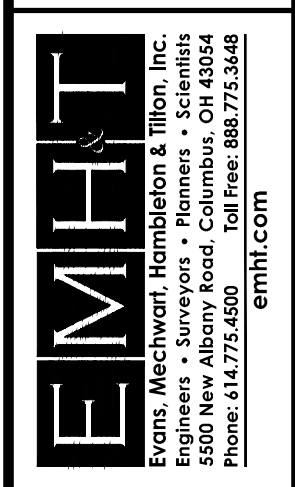

DATE
May 20, 2024

SCALE
NONE

JOB NO.
20240265

SHEET
11/11

PRELIMINARY
NOT TO BE USED FOR
CONSTRUCTION

PLAN SET DATE
May 20, 2024

I:\2024\265\Drawings\Sheets\Concept_Plan\20240265-Typical Sections.dwg - Last Saved By: mbucke_5/20/2024 11:44 AM - Last Printed By: mbucke_5/20/2024 11:48 AM (No Xrefs)



CLIFTON CUSTOM EXTERIOR DESIGN
4-HOME BUILDING

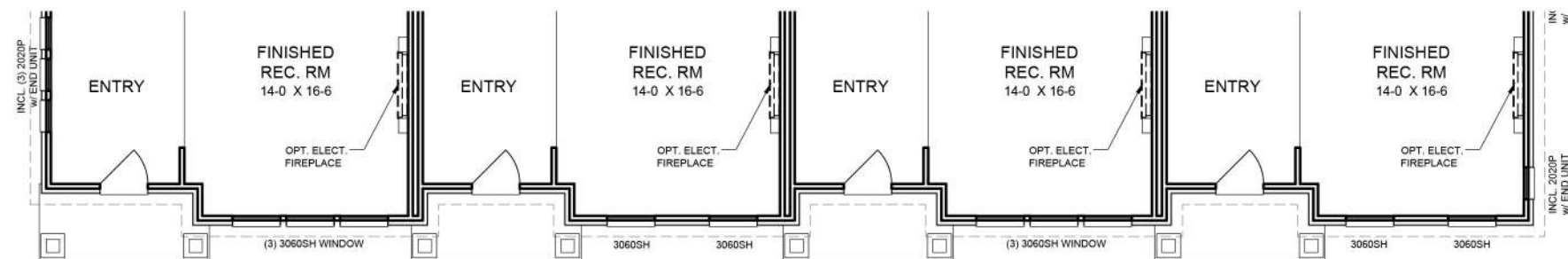

PARTIAL ENTRY LEVEL PLAN
4-HOME BUILDING

THREE STORY TOWNHOME DESIGN STUDY
REAR ENTRY GARAGE
(Z-23-44)

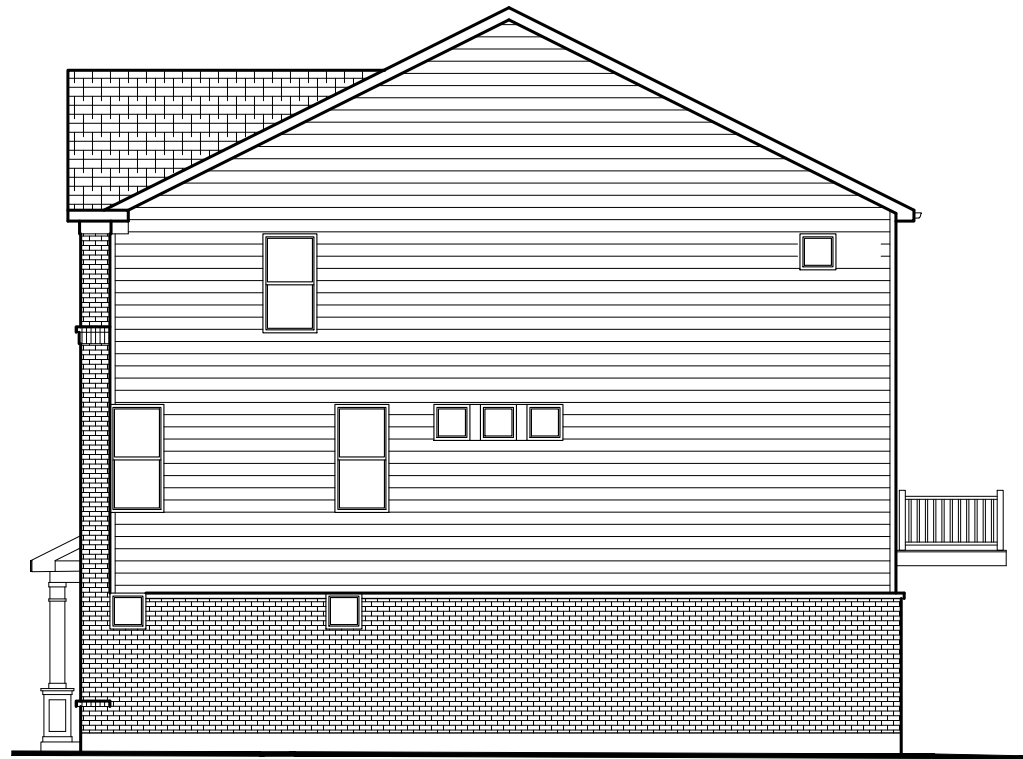

CLIFTON CUSTOM EXTERIOR DESIGN -RIGHT SIDE ELEVATION
4-HOME BUILDING

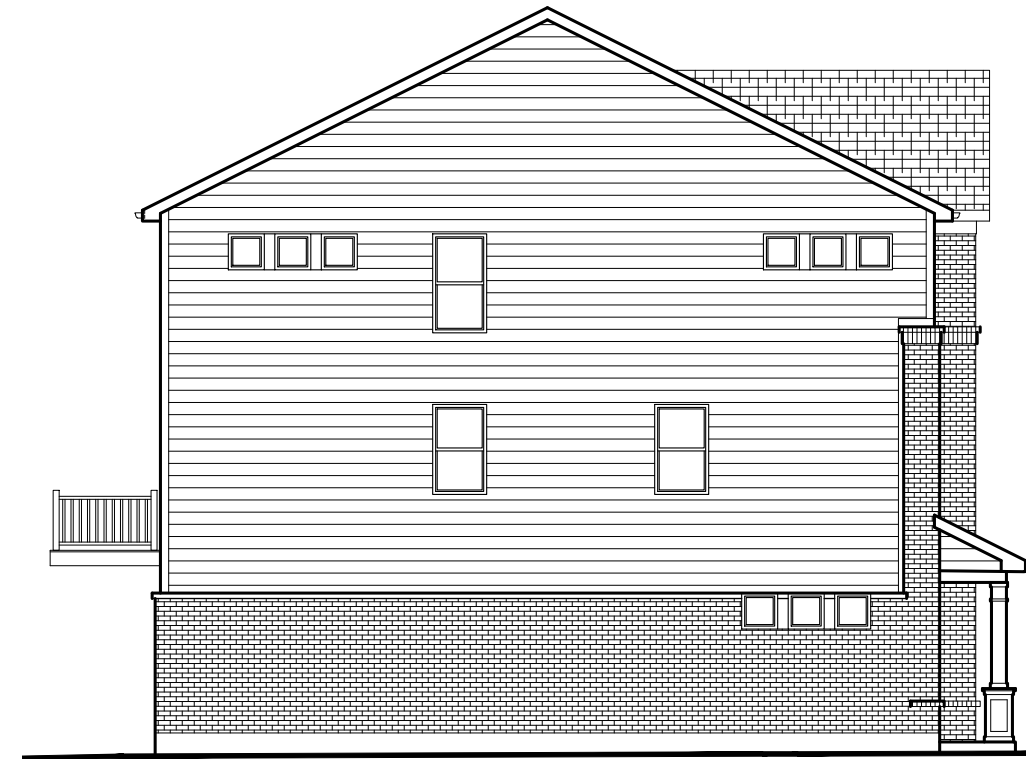

CLIFTON CUSTOM EXTERIOR DESIGN -LEFT SIDE ELEVATION
4-HOME BUILDING



CLIFTON CUSTOM EXTERIOR DESIGN -REAR ELEVATION
4-HOME BUILDING

THREE STORY TOWNHOME DESIGN STUDY
REAR ENTRY GARAGE
(Z-23-44)



Thank You.