



AT&T

AT&T SITE NAME: SOH3567

AT&T SITE NUMBER: AVERY PARK WT

SITE ADDRESS: 7699 AVERY ROAD
DUBLIN, OH 43017
FRANKLIN COUNTY

AT&T FA CODE: 10070814

PACE JOB NUMBER: MROWP077895, MROWP078223,
MROWP077648, MROWP078517,
MROWP078381, MROWP077545,
MROWP078710, MROWP078926.

SITE INFORMATION

OWNER: CITY OF DUBLIN

JURISDICTION: CITY OF DUBLIN

LATITUDE (NAD 83): 40° 7' 41.00016" N (40.1280556° N)

LONGITUDE (NAD 83): 83° 9' 43.99992" W (83.1622222° W)

GROUND ELEVATION: 920.14' (NAVD 88)

STRUCTURE TYPE: 170'-0" WATER TANK

PARCEL ID: N/A

PROJECT DESCRIPTION

THE PURPOSE OF THIS PROJECT IS TO PROVIDE THE CONSTRUCTION DRAWINGS

TOWER EQUIPMENT TO REMOVE:

- (3) 80010798 ANTENNAS
- (3) AIRSCALE MAA 64T64R 192AE N77 200W AEQK
- (3) RRH4X25-WCS-4R RRUS
- (3) AIRSCALE DUAL RRH 4T4R B12/14 320W AHLBA RRUS
- (3) AIRSCALE DUAL RRH 4T4R B25/66 320W AHFIB RRUS
- (3) AIRSCALE RRH 4T4R B5 160W AHCA RRUS

TOWER EQUIPMENT TO RELOCATE:

- (3) NNH4-65C-R6 ANTENNAS FROM P2 TO P1 EACH SECTOR

EXISTING TOWER EQUIPMENT TO REUSE:

- (3) NNH4-65C-R6 ANTENNAS
- (2) DC6-48-60-18-8F
- (1) DC9-48-60-24-8C-EV
- (4) WR-VG66ST-BRD 6AWG DC
- (2) WR-VGCO43ST-BRD 4AWG DC
- (2) 18 PAIR FIBER TRUNK
- (1) 24 PAIR FIBER TRUNK
- (12) 1 5/8" COAX

TOWER SCOPE OF WORK TO INSTALL:

- (3) AIR6419 B77D ANTENNAS
- (3) AIR6419 B77G ANTENNAS
- (3) 4490 B5/B12 RRUS
- (3) 4415 B30 RRUS
- (3) 4478 B14 RRUS
- (3) 4890 B25/B66 RRUS
- (6) AIR ANTENNA BRACKETS

GROUND SCOPE OF WORK TO REMOVE:

- (18) LGP13519 DIPLEXERS
- (3) 24V CONVERTERS
- NOKIA BBUS

GROUND SCOPE OF WORK TO REUSE:

- (1) D2 SIAD
- (2) DC6-48-60-RM GEN 1
- (2) DC12-48-60-RM GEN 1
- (12) R48-2000E3 RECTIFIERS
- (1) BATTERY RACK
- (24) HT170ET INSTALLED 04/2021 BATTERIES TO REMAIN (3 STRINGS IN BATTERY RACK AND 3 STRINGS IN PP)

GROUND SCOPE OF WORK TO INSTALL:

- UPGRADE EXISTING NS 7100 48/24 PP TO 58V WITH UPGRADE KIT
- (1) RECTIFIER/CONVERTER SHELF
- (10) C48/58-2000P3 CONVERTERS
- (2) 6651 BBUS AND (1) 6610 SITE CONTROLLER
- ADD 2ND GPS RECEIVER AND SPLITTER WITH 10FT SPACING
- (1) FIBER PATCH PANEL
- (21) NEW BREAKERS
- LAND BOTH SIDES OF GMT FUSE PANEL TO 48V WHEN SWAPPING PP TO 48/58 "
- AC ELECTRICAL WORK WILL NOT BE ALTERED

DRAWING INDEX

SHEET	DESCRIPTION
T-1	TITLE SHEET
GN-1	GENERAL NOTES
GN-2	GENERAL NOTES
C-1	OVERALL SITE PLAN
C-2	EXISTING & NEW EQUIPMENT LAYOUT
C-3	STRUCTURE ELEVATIONS
C-4	EXISTING & NEW ANTENNA CONFIGURATION
C-5	EXISTING ANTENNA & EQUIPMENT SCHEDULE
C-6	NEW ANTENNA & EQUIPMENT SCHEDULE
C-7	EQUIPMENT DETAILS
C-8	EQUIPMENT DETAILS
C-9	EQUIPMENT DETAILS
C-10	MOUNT DETAILS
C-11	PLUMBING DIAGRAM
G-1	GROUNDING DETAILS
G-2	GROUNDING DETAILS

ALL DRAWINGS CONTAINED HEREIN ARE FORMATTED FOR 11X17. CONTRACTOR SHALL VERIFY ALL PLANS, EXISTING DIMENSIONS, CONDITIONS ON THE JOB SITE AND SHALL IMMEDIATELY NOTIFY THE ARCHITECT OR ENGINEER IN WRITING OF ANY DISCREPANCIES BEFORE PROCEEDING WITH THE WORK OR BE RESPONSIBLE FOR THE SAME.

CODE COMPLIANCE

ALL WORK SHALL BE PERFORMED AND MATERIALS INSTALLED IN ACCORDANCE WITH GOVERNING AUTHORITIES. NOTHING IN THESE PLANS IS TO BE CONSTRUED TO PERMIT WORK NOT CONFORMING TO THESE CODES.

- 2024 OHIO BUILDING CODE (OBC)
- 2024 OHIO PLUMBING CODE (OPC)
- 2024 OHIO MECHANICAL CODE (OMC)
- 2024 NATIONAL ELECTRICAL CODE (NEC)
- 2024 OHIO FIRE CODE (OFC)



14708 CUSTER RD., SUITE 102
OMAHA, NE 68138
(844) 886-9377

I HEREBY CERTIFY THAT THIS ENGINEERING DOCUMENT WAS PREPARED BY ME OR UNDER MY DIRECT PERSONAL SUPERVISION AND THAT I AM A DAILY LICENSED PROFESSIONAL ENGINEER UNDER THE LAWS OF THE STATE OF OHIO

REVISIONS

REV.	DATE	BY	DESCRIPTION	QA
A	06/17/24	JA	PRELIM CD 95%	DS

PROJECT TEAM

SITE ACQUISITION MANAGER: ERICSSON

ENGINEERING SERVICES: SGS TOWERS
14708 CUSTER RD., SUITE 102
OMAHA, NE 68138
CONTACT: DEEPESH SAVLA
PHONE: (844) 886-9377
EMAIL: engineering@sgstowers.com

DRIVING DIRECTIONS

FROM 4199 WEAVER CTHILLIARD, OH 43026 1. HEAD NORTH ON WEAVER CT TOWARD NORTHWEST PKWY 26 FT 2. TAKE THE 1ST LEFT ONTO NORTHWEST PKWY 0.6 MI 3. TURN RIGHT AT AVERY RD 3.8 MI 4. AT THE TRAFFIC CIRCLE, TAKE THE 2ND EXIT AND STAY ON AVERY RD 1.1 MI 5. AT THE TRAFFIC CIRCLE, TAKE THE 2ND EXIT ONTO AVERY-MUIRFIELD DR 0.3 MI 6. TURN LEFT AT AVERY MUIRFIELD DR/CO 3 CONTINUE TO FOLLOW AVERY MUIRFIELD DR 213 FT 7. CONTINUE ONTO AVERY RD DESTINATION WILL BE ON THE LEFT 1.0 MI 7699 AVERY RDDUBLIN, OH 43017

VICINITY MAP

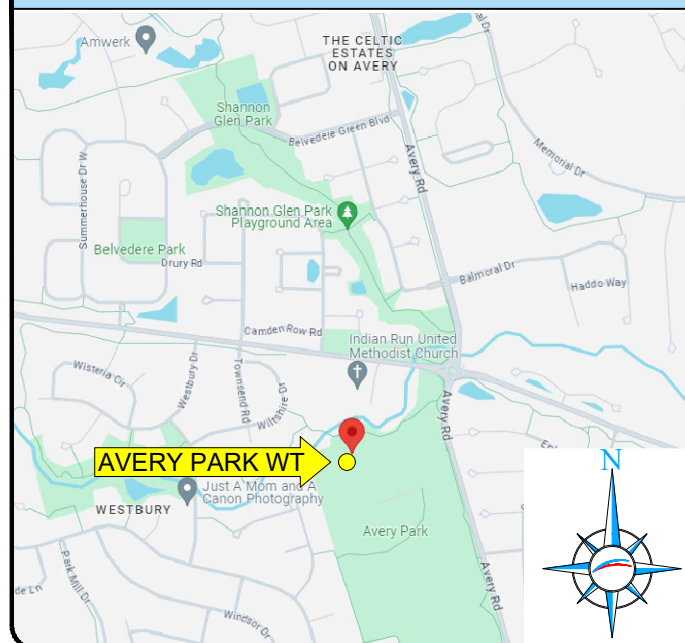

LOCAL MAP



LOCATION



ONE CALL



Know what's below.
Call before you dig.

REFERENCE DOCUMENTS

DOCUMENT TYPE	DESIGNATION	DATE
MOUNT ANALYSIS	SGS TOWERS JOB NUMBER: 2405260	06/12/2024
PASSING STRUCTURAL ANALYSIS	XXX PROJECT NUMBER : TBD	TBD

SOH3567

7699 AVERY ROAD
DUBLIN, OH 43017

SGS# : 2405261

SHEET TITLE

TITLE SHEET

SHEET NUMBER

T-1

REVISION

0

GENERAL NOTES

- INFORMATION SHOWN ON THESE DRAWINGS WAS OBTAINED FROM SITE VISITS AND/OR DRAWINGS PROVIDED BY THE OWNER. CONTRACTOR SHALL BE RESPONSIBLE FOR FAMILIARIZING THEMSELVES WITH ALL CONTRACT DOCUMENTS, FIELD CONDITIONS, DIMENSIONS, AND CONFIRMING THAT THE WORK MAY BE ACCOMPLISHED AS SHOWN PRIOR TO PROCEEDING WITH CONSTRUCTION. CONTRACTORS SHALL NOTIFY SGS TOWERS OF ANY DISCREPANCIES OR INCONSISTENCIES PRIOR TO PROCEEDING WITH CONSTRUCTION.
- PLANS ARE NOT TO BE SCALED. THESE PLANS ARE INTENDED TO BE A DIAGRAMMATIC OUTLINE ONLY UNLESS OTHERWISE NOTED. DETAILS ARE INTENDED TO SHOW DESIGN INTENT. MODIFICATIONS MAY BE REQUIRED TO SUIT JOB DIMENSIONS OR CONDITIONS AND SUCH MODIFICATIONS SHALL BE INCLUDED AS PART OF WORK AND PREPARED BY THE ENGINEER PRIOR TO PROCEEDING WITH WORK.
- ALL WORK CARRIED OUT SHALL COMPLY WITH ALL APPLICABLE MUNICIPAL AND UTILITY COMPANY SPECIFICATIONS AND LOCAL JURISDICTIONAL CODES, ORDINANCES, AND APPLICABLE REGULATIONS. THE CONTRACTOR AGREES THAT IN ACCORDANCE WITH GENERALLY ACCEPTED CONSTRUCTION PRACTICES, CONTRACTOR WILL BE REQUIRED TO ASSUME SOLE AND COMPLETE RESPONSIBILITY FOR JOB SITE CONDITIONS DURING THE COURSE OF CONSTRUCTION OF THE PROJECT DURING NORMAL WORKING HOURS. THE CONTRACTOR SHALL BE RESPONSIBLE FOR OBTAINING ALL PERMITS AND INSPECTIONS REQUIRED FOR CONSTRUCTION.
- CONTRACTOR SHALL BE RESPONSIBLE FOR THE SAFETY OF WORK AREA, ADJACENT AREAS AND BUILDING OCCUPANTS THAT ARE LIKELY TO BE AFFECTED BY THE WORK UNDER THIS CONTRACT. WORK SHALL CONFIRM TO ALL OSHA REQUIREMENTS AND THE LOCAL JURISDICTION. THE CONTRACTOR SHALL BE RESPONSIBLE FOR SECURITY OF THE SITE FOR THE DURATION OF CONSTRUCTION UNTIL JOB COMPLETION.
- IF THE SPECIFIED EQUIPMENT CANNOT BE INSTALLED AS SHOWN ON THESE DRAWINGS, THE CONTRACTOR SHALL PROPOSE AN ALTERNATIVE INSTALLATION SPACE FOR APPROVAL BY THE ENGINEER PRIOR TO PROCEEDING.
- UNLESS NOTED OTHERWISE, THE WORK SHALL INCLUDE FURNISHING OF MATERIALS, EQUIPMENT, APPURTENANCES, AND LABOR NECESSARY TO COMPLETE ALL INSTALLATIONS AS INDICATED WITHIN THE CONSTRUCTION DRAWINGS. THE CONTRACTOR SHALL INSTALL ALL EQUIPMENT AND MATERIALS IN ACCORDANCE WITH MANUFACTURER'S RECOMMENDATIONS UNLESS SPECIFICALLY STATED OTHERWISE.
- IF TEMPORARY LIGHTING AND MARKING IS REQUIRED BY THE FEDERAL AVIATION ADMINISTRATION (FAA), IT IS THE CONTRACTOR'S RESPONSIBILITY TO MAINTAIN THE NECESSARY LIGHTS AND NOTIFY THE PROPER AUTHORITIES IN THE EVENT OF A PROBLEM.
- DEMOLITION AND CONSTRUCTION ACTIVITIES SHALL BE ACCOMPLISHED IN SUCH A MANNER THAT NO DISRUPTION OF EXISTING FACILITY OPERATIONS WILL OCCUR.
- CONTRACTOR SHALL MAINTAIN IN GOOD CONDITION ONE COMPLETE SET OF PLANS WITH ALL REVISIONS, ADDENDA, AND CHANGE ORDERS ON THE PREMISES AT ALL TIMES.
- CONTRACTOR SHALL LEAVE PREMISES IN A CLEAN CONDITION.

SYMBOLS & CALL-OUTS

TYPICAL DETAIL CALL-OUT

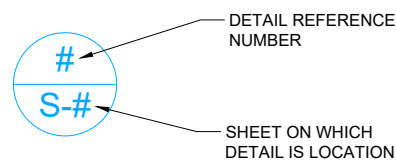

NOTE:
DETAIL CALL-OUT
INFORMATION IS THE SAME
FOR SECTION CALL-OUTS

TYPICAL SECTION CALL-OUT

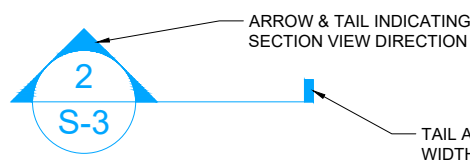

ANTENNA MOUNTING NOTES

- DESIGN AND CONSTRUCTION OF ANTENNA SUPPORTS SHALL CONFORM TO CURRENT ANSI/TIA-222 OR APPLICABLE LOCAL CODES.
- IF RIGGING TO MOUNT, CONSULT WITH A QUALIFIED ENGINEER PRIOR TO CONSTRUCTION.
- ALL ANTENNA MOUNTS SHALL BE INSTALLED WITH LOCK NUTS, DOUBLE NUTS AND SHALL BE TORQUED TO MANUFACTURER'S RECOMMENDATIONS.
- CONTRACTOR SHALL INSTALL ANTENNA PER MANUFACTURER'S RECOMMENDATION FOR INSTALLATION AND GROUNDING.
- PRIOR TO SETTING ANTENNA AZIMUTHS AND DOWNTILTS, CONTRACTOR SHALL CHECK THE ANTENNA MOUNT FOR TIGHTNESS AND ENSURE THAT THEY ARE PLUMB. ANTENNA AZIMUTHS SHALL BE SET FROM TRUE NORTH AND BE ORIENTED WITHIN +/- 5% AS DEFINED BY THE OWNER'S SPECIFICATIONS. ANTENNA DOWNTILTS SHALL BE WITHIN +/- 0.5% AS DEFINED BY THE OWNER'S SPECIFICATIONS AND VERIFIED USING A DIGITAL LEVEL.
- EQUIPMENT SHALL BE MOUNTED ON PIPE DIRECTLY BEHIND ANTENNA AS CLOSE TO ANTENNA AS FEASIBLE IN A VERTICAL POSITION.
- ALL STEEL MATERIALS SHALL BE GALVANIZED AFTER FABRICATION IN ACCORDANCE WITH MOST RECENT VERSION OF ASTM A123 "ZINC (HOT-DIP GALVANIZED) COATINGS ON IRON AND STEEL PRODUCTS", UNLESS NOTED OTHERWISE.
- ALL BOLTS, ANCHORS AND MISCELLANEOUS HARDWARE SHALL BE GALVANIZED IN ACCORDANCE WITH MOST RECENT VERSION OF ASTM A153 "ZINC-COATING (HOT-DIP) ON IRON AND STEEL HARDWARE", UNLESS NOTED OTHERWISE.
- DAMAGED GALVANIZED SURFACES SHALL BE REPAIRED BY COLD GALVANIZING IN ACCORDANCE WITH MOST RECENT VERSION OF ASTM A780 "REPAIR OF DAMAGED AND UNCOATED AREAS OF HOT-DIP GALVANIZED COATINGS".
- ENSURE MOUNT DOES NOT IMPEDE SAFETY CLIMB.

CABLE NOTES

- CONTRACTOR SHALL BE RESPONSIBLE TO VERIFY COAX CONFIGURATIONS AND MAKE AND MODELS OF ANTENNAS, TMAs, AND DIPLEXERS PRIOR TO INSTALLATION.
- CONTRACTOR SHALL REFERENCE THE TOWER STRUCTURAL ANALYSIS AND CONSTRUCTION DRAWINGS FOR DIRECTIONS ON CABLE ROUTING AND DISTRIBUTION. TYPES AND SIZES OF THE ANTENNA CABLE ARE BASED ON ESTIMATED LENGTHS. CONTRACTOR SHALL VERIFY ACTUAL LENGTHS BASED ON CONSTRUCTION LAYOUT.
- CONTRACTOR SHALL LEGALLY AND PROPERLY DISPOSE OF ALL SCRAP MATERIALS SUCH AS COAXIAL CABLES AND OTHER ITEMS REMOVED FROM THE EXISTING FACILITY.
- CONTRACTOR SHALL PROVIDE STRAIN-RELIEF AND CABLE SUPPORTS FOR ALL CABLE ASSEMBLIES, COAX CABLES, CONTROL CABLES, HANGERS, BRACING ETC. AND SHALL BE INSTALLED PER TOWER MANUFACTURER'S SPECIFICATIONS AND RECOMMENDATIONS.
- CONTRACTOR SHALL FOLLOW ALL MANUFACTURER'S INSTALLATION AND GROUNDING RECOMMENDATIONS REGARDING ALL COAXIAL CABLES, CONNECTORS, ANTENNAS, AND ALL OTHER EQUIPMENT. GROUNDING SHALL BE EXECUTED BY QUALIFIED WIREMEN IN COMPLIANCE WITH MANUFACTURER'S SPECIFICATIONS AND RECOMMENDATIONS.
 - GROUNDING AT THE ANTENNA LEVEL.
 - GROUNDING AT MID LEVEL, TOWERS WHICH ARE OVER 200'-0", ADDITIONAL CABLE GROUNDING REQUIRED.
 - GROUNDING AT BASE OF TOWER PRIOR TO TURNING HORIZONTAL.
 - GROUNDING OUTSIDE THE EQUIPMENT SHELTER AT ENTRY PORT.
 - GROUNDING INSIDE THE EQUIPMENT SHELTER AT THE ENTRY PORT.
- CONTRACTOR SHALL WEATHERPROOF ALL ANTENNA CONNECTORS WITH SELF AMALGAMATING TAPE. WEATHERPROOFING SHALL BE COMPLETED IN STRICT ACCORDANCE WITH THE OWNER'S STANDARDS.
- IF REQUIRED TO PAINT ANTENNAS AND/OR COAX:
 - TEMPERATURE SHALL BE ABOVE 50° F.
 - PAINT COLOR MUST BE APPROVED BY BUILDING OWNER/LANDLORD.
 - FOR REGULATED TOWERS, FAA/FCC APPROVED PAINT IS REQUIRED.
 - DO NOT PAINT OVER COLOR CODING OR ON EQUIPMENT MODEL NUMBER.

PRODUCT NOTES

- ALL STRUCTURAL STEEL WORK SHALL BE DONE IN ACCORDANCE WITH AISC 15TH EDITION SPECIFICATIONS.
- ALL MATERIALS FURNISHED AND INSTALLED SHALL BE IN STRICT ACCORDANCE WITH ALL APPLICABLE CODES, REGULATIONS, AND ORDINANCE.
- STRUCTURAL STEEL:
 - SHAPES, PLATES AND BARS SHALL CONFORM TO ASTM A36 AND ASTM A992.
 - STRUCTURAL TUBING SHALL CONFORM TO ASTM A500, GRADE B.
 - STEEL PIPE SHALL CONFORM TO ASTM A53, TYPE E OR S, GRADE B.
- ANCHOR BOLTS:
 - ANCHOR BOLTS SHALL CONFORM TO ASTM A307 WITH HEAVY HEXAGONAL NUTS.
- BOLTS:
 - COMMON (MACHINE) BOLTS SHALL CONFORM TO ASTM A307 GRADE A AND NUTS TO ASTM A563. ONE COMMON BOLT ASSEMBLY SHALL CONSIST OF A BOLT, A HEAVY HEX NUT, AND A HARDENED WASHER.
 - HIGH STRENGTH BOLT SHALL CONFORM TO ASTM A325, ONE HIGH STRENGTH BOLT ASSEMBLY SHALL CONSIST OF A HEAVY HEX STRUCTURAL BOLT, A HEAVY HEX NUT, A HARDENED WASHER CONFORMING WITH ASTM F436 AND A DIRECT TENSION INDICATOR CONFORMING WITH ASTM F959. THE HARDENED WASHER SHALL BE INSTALLED AGAINST THE ELEMENT TURNED IN TIGHTENING. UNLESS NOTED OTHERWISE ON THE DRAWINGS, ALL CONNECTIONS SHALL BE BEARING TYPE CONNECTIONS.
- WELDING ELECTRODES:
 - WELDING ELECTRODES SHALL COMPLY WITH AWS D1.1 USING A5.1 OR A5.5 E70XX AND SHALL BE COMPATIBLE WITH THE WELDING PROCESS SELECTED.
- PRIMER:
 - PRIMER SHALL BE RED OXIDE-CHROMATE PRIMER COMPLYING WITH SSPC PAINT SPECIFICATION NO. 11.

REFERENCES

- AMERICAN INSTITUTE OF STEEL CONSTRUCTION (AISC):
 - STEEL CONSTRUCTION MANUAL (15TH EDITION).
- AMERICAN SOCIETY FOR TESTING AND MATERIALS (ASTM):
 - ASTM A36: STRUCTURAL STEEL
 - ASTM A53: PIPE, STEEL BLACK AND HOT DIPPED, ZINC-COATED WELDED AND SEAMLESS.
 - ASTM A108: STEEL BARS, CARBON, COLD FINISHED, STANDARD QUALITY.
 - ASTM A123: ZINC (HOT-DIPPED GALVANIZED) COATING ON IRON AND STEEL PRODUCTS.
 - ASTM A307: CARBON STEEL BOLTS AND STUDS, 60,000 PSI TENSILE STRENGTH.
 - ASTM A325: HIGH-STRENGTH BOLT FOR STRUCTURAL STEEL JOINTS.
 - ASTM A490: HEAT-TREATED, STRUCTURAL STEEL BOLTS, 150 (KSI) (1035MPA) TENSILE STRENGTH.
 - ASTM A500: COLD-FORMED WELDED AND SEAMLESS CARBON STEEL STRUCTURAL TUBING IN ROUNDS AND SHAPES.
 - ASTM A563: ARCBON AND ALLOY STEEL NUTS.
 - ASTM B695: COATINGS OF ZINC MECHANICALLY DEPOSITED ON IRON AND STEEL.
 - ASTM F436: HARDENED STEEL WASHERS.
 - ASTM F959: COMPRESSIBLE-WASHER-TYPE DIRECT TENSION INDICATOR FOR USE WITH STRUCTURAL FASTENERS.
- AMERICAN WELDING SOCIETY (AWS):
 - AWS A5.1: COVERED CARBON STEEL ARC WELDING ELECTRODES.
 - AWS A5.5: LOW ALLOY STEEL COVERED ARC WELDING ELECTRODES.
 - AWS D1.1: STRUCTURAL WELDING CODE - STEEL.



ERICSSON



14708 CUSTER RD., SUITE 102
OMAHA, NE 68138
(844) 886-9377

I HEREBY CERTIFY THAT THIS ENGINEERING DOCUMENT WAS PREPARED BY ME OR UNDER MY DIRECT PERSONAL SUPERVISION AND THAT I AM A DAILY LICENSED PROFESSIONAL ENGINEER UNDER THE LAWS OF THE STATE OF OHIO

REVISIONS

REV.	DATE	BY	DESCRIPTION	QA
A	06/17/24	JA	PRELIM CD 95%	DS

SOH3567

7699 AVERY ROAD
DUBLIN, OH 43017

SGS# : 2405261

SHEET TITLE

GENERAL NOTES

SHEET NUMBER

GN-1

REVISION

0

ELECTRICAL INSTALLATION NOTES

- ALL ELECTRICAL WORK SHALL BE PERFORMED IN ACCORDANCE WITH THE PROJECT SPECIFICATIONS, NEC AND ALL APPLICABLE FEDERAL, STATE, AND LOCAL CODES/ORDINANCES.
- CONDUIT ROUTINGS ARE SCHEMATIC. SUBCONTRACTOR SHALL INSTALL CONDUITS SO THAT ACCESS TO EQUIPMENT IS NOT BLOCKED AND TRIP HAZARDS ARE ELIMINATED.
- WIRING, RACEWAY AND SUPPORT METHODS AND MATERIALS SHALL COMPLY WITH THE REQUIREMENTS OF THE NEC. HILTI EPOXY ANCHORS ARE REQUIRED BY CROWN CASTLE USA INC.
- ALL CIRCUITS SHALL BE SEGREGATED AND MAINTAIN MINIMUM CABLE SEPARATION AS REQUIRED BY THE NEC.
- CABLES SHALL NOT BE ROUTED THROUGH LADDER-STYLE CABLE TRAY RUNGS.
- EACH END OF EVERY POWER, POWER PHASE CONDUCTOR (I.E., HOTS), GROUNDING AND T1 CONDUCTOR AND CABLE SHALL BE LABELED WITH COLOR-CODED INSULATION OR ELECTRICAL TAPE (3M BRAND, 1/2" PLASTIC ELECTRICAL TAPE WITH UV PROTECTION, OR EQUAL). THE IDENTIFICATION METHOD SHALL CONFORM WITH NEC AND OSHA.
- ALL ELECTRICAL COMPONENTS SHALL BE CLEARLY LABELED WITH PLASTIC TAPE PER COLOR SCHEDULE. ALL EQUIPMENT SHALL BE LABELED WITH THEIR VOLTAGE RATING, PHASE CONFIGURATION, WIRE CONFIGURATION, POWER OR AMPACITY RATING AND BRANCH CIRCUIT ID NUMBERS (I.E. PANEL BOARD AND CIRCUIT ID'S).
- PANEL BOARDS (ID NUMBERS) AND INTERNAL CIRCUIT BREAKERS (CIRCUIT ID NUMBERS) SHALL BE CLEARLY LABELED WITH PLASTIC LABELS.
- ALL TIE WRAPS SHALL BE CUT FLUSH WITH APPROVED CUTTING TOOL TO REMOVE SHARP EDGES.
- POWER, CONTROL AND EQUIPMENT GROUND WIRING IN TUBING OR CONDUIT SHALL BE SINGLE CONDUCTOR (#14 AWG OR LARGER), 600 V, OIL RESISTANT THHN OR THWN-2, CLASS B STRANDED COPPER CABLE RATED FOR 90° C (WET & DRY) OPERATION LISTED OR LABELED FOR THE LOCATION AND RACEWAY SYSTEM USED UNLESS OTHERWISE SPECIFIED.
- SUPPLEMENTAL EQUIPMENT GROUND WIRING LOCATED INDOORS SHALL BE SINGLE CONDUCTOR (#6 AWG OR LARGER), 600V, OIL RESISTANT THHN OR THWN-2 GREEN INSULATION CLASS B STRANDED COPPER CABLE RATED FOR 90° C (WET AND DRY) OPERATION LISTED OR LABELED FOR THE LOCATION AND RACEWAY SYSTEM USED UNLESS OTHERWISE SPECIFIED.
- POWER AND CONTROL WIRING, NOT IN TUBING OR CONDUIT, SHALL BE MULTI-CONDUCTOR, TYPE TC CABLE (#14 AWG OR LARGER), 600 V, OIL RESISTANT THHN OR THWN-2, CLASS B STRANDED COPPER CABLE RATED FOR 90° C (WET AND DRY) OPERATION WITH OUTER JACKET LISTED OR LABELED FOR THE LOCATION USED UNLESS OTHERWISE SPECIFIED.
- ALL POWER AND GROUNDING CONNECTIONS SHALL BE CRIMP-STYLE, COMPRESSION WIRE LUGS AND WIRE NUTS BY THOMAS AND BETTS (OR EQUAL). LUGS AND WIRE NUTS SHALL BE RATED FOR OPERATION AT NO LESS THAN 75° C (90° C IF AVAILABLE).
- RACEWAY AND CABLE TRAY SHALL BE LISTED OR LABELED FOR ELECTRICAL USE IN ACCORDANCE WITH NEMA, UL, ANSII/IEEE AND NEC.
- RIGID METALLIC CONDUIT (RMC) SHALL BE USED FOR EXPOSED INDOOR LOCATIONS.
- RIGID METALLIC CONDUIT (RMC) SHALL BE USED FOR CONCEALED INDOOR LOCATIONS.
- SCHEDULE 40 PVC UNDERGROUND ON STRAIGHTS AND SCHEDULE 80 PVC FOR ALL ELBOWS/90S AND ALL APPROVED ABOVE GRADE PVC CONDUIT.
- LIQUID-TIGHT FLEXIBLE METALLIC CONDUIT (LIQUID-TITE FLEX) SHALL BE USED INDOORS AND OUTDOORS, WHERE VIBRATION OCCURS OR FLEXIBILITY IS NEEDED.
- CONDUIT AND TUBING FITTINGS SHALL BE THREADED OR COMPRESSION-TYPE AND APPROVED FOR THE LOCATION USED. SET SCREW FITTINGS ARE NOT ACCEPTABLE.
- CABINETS, BOXES AND WIRE WAYS SHALL BE LABELED FOR ELECTRICAL USE IN ACCORDANCE WITH NEMA, UL, ANSII/IEEE AND NEC.
- WIREWAYS SHALL BE EPOXY-COATED (GRAY) AND INCLUDE A HINGED COVER, DESIGNED TO SWING OPEN DOWNWARDS; SHALL BE PANDUIT TYPE E (OR EQUAL); AND RATED NEMA 1 (OR BETTER).
- CONDUITS SHALL BE FASTENED SECURELY IN PLACE WITH APPROVED NON-PERFORATED STRAPS AND HANGERS. EXPLOSIVE DEVICES FOR ATTACHING HANGERS TO STRUCTURE WILL NOT BE PERMITTED. CLOSELY FOLLOW THE LINES OF THE STRUCTURE, MAINTAIN CLOSE PROXIMITY TO THE STRUCTURE AND KEEP CONDUITS IN TIGHT ENVELOPES. CHANGES IN DIRECTION TO ROUTE AROUND OBSTACLES SHALL BE MADE WITH CONDUIT OUTLET BODIES. CONDUIT SHALL BE INSTALLED IN A NEAT AND WORKMANLIKE MANNER. PARALLEL AND PERPENDICULAR TO STRUCTURE WALL AND CEILING LINES. ALL CONDUIT SHALL BE FISHED TO CLEAR OBSTRUCTIONS. ENDS OF CONDUITS SHALL BE TEMPORARILY CAPPED FLUSH TO FINISH GRADE TO PREVENT CONCRETE, PLASTER OR DIRT FROM ENTERING. CONDUITS SHALL BE RIGIDLY CLAMPED TO BOXES BY GALVANIZED MALLEABLE IRON BUSHIN ON INSIDE AND GALVANIZED MALLEABLE IRON LOCKNUT ON OUTSIDE AND INSIDE.
- EQUIPMENT CABINETS, TERMINAL BOXES, JUNCTION BOXES AND PULL BOXES SHALL BE GALVANIZED OR EPOXY-COATED SHEET STEEL; SHALL MEET OR EXCEED UL 50 AND RATED NEMA 1 (OR BETTER) INDOORS OR NEMA 3R (OR BETTER) OUTDOORS.
- METAL RECEPTACLE, SWITCH AND DEVICE BOXES SHALL BE GALVANIZED, EPOXY-COATED OR NON-CORRODING; SHALL MEET OR EXCEED UL 514A AND NEMA OS 1; AND RATED NEMA 1 (OR BETTER) INDOORS OR WEATHER PROTECTED (WP OR BETTER) OUTDOORS.

CONT. ELECTRICAL INSTALLATION NOTES

- NONMETALLIC RECEPTACLE, SWITCH AND DEVICE BOXES SHALL MEET OR EXCEED NEMA OS 2; AND RATED NEMA 1 (OR BETTER) INDOORS OR WEATHER PROTECTED (WP OR BETTER) OUTDOORS.
- THE SUBCONTRACTOR SHALL NOTIFY AND OBTAIN NECESSARY AUTHORIZATION FROM THE CONTRACTOR BEFORE COMMENCING WORK ON THE AC POWER DISTRIBUTION PANELS.
- THE SUBCONTRACTOR SHALL PROVIDE NECESSARY TAGGING ON THE BREAKERS, CABLES AND DISTRIBUTION PANELS IN ACCORDANCE WITH THE APPLICABLE CODES AND STANDARDS TO SAFEGUARD LIFE AND PROPERTY.
- INSTALL PLASTIC LABEL ON THE METER CENTER TO SHOW "MOTOROLA".
- ALL CONDUITS THAT ARE INSTALLED ARE TO HAVE A METERED MULE TAPE PULL CORD INSTALLED.

CONCRETE & REINFORCING STEEL NOTES

- ALL CONCRETE WORK SHALL BE IN ACCORDANCE WITH THE ACI 301, ACI 318, ACI 336, ASTM A184, ASTM A185 AND THE DESIGN AND CONSTRUCTION SPECIFICATION FOR CAST-IN-PLACE CONCRETE.
- ALL CONCRETE SHALL HAVE A MINIMUM COMPRESSIVE STRENGTH OF 3000 PSI AT 28 DAYS, UNLESS NOTED OTHERWISE. SLAB FOUNDATION DESIGN ASSUMING ALLOWABLE SOIL BEARING PRESSURE OF 2000 PSF.
- REINFORCING STEEL SHALL CONFORM TO ASTM A615, GRADE 60, DEFORMED UNLESS NOTED OTHERWISE. WELDED WIRE FABRIC SHALL CONFORM TO ASTM A185 WELDED STEEL WIRE FABRIC UNLESS NOTED OTHERWISE. SPLICES SHALL BE CLASS "B" AND ALL HOOKS SHALL BE STANDARD, UNO.
- THE FOLLOWING MINIMUM CONCRETE COVER SHALL BE PROVIDED FOR REINFORCING STEEL UNLESS SHOWN OTHERWISE ON DRAWINGS:

 CONCRETE CAST AGAINST EARTH.....3 IN.
 CONCRETE EXPOSED TO EARTH OR WEATHER:
 #6 AND LARGER.....2 IN.
 #5 AND SMALLER & WWF.....1 1/2 IN.
 CONCRETE NOT EXPOSED TO EARTH OR WEATHER OR NOT CAST AGAINST THE GROUND:
 SLAB AND WALLS.....3/4 IN.
 BEAMS AND COLUMNS.....1 1/2 IN.
- A CHAMFER 3/4" SHALL BE PROVIDED AT ALL EXPOSED EDGES OF CONCRETE, UNLESS NOTED OTHERWISE. IN ACCORDANCE WITH ACI 301 SECTION 4.2.4.

MASONRY NOTES

- HOLLOW CONCRETE MASONRY UNITS SHALL MEET A.S.T.M. SPECIFICATION C90, GRADE N. TYPE 1. THE SPECIFIED DESIGN COMPRESSIVE STRENGTH OF CONCRETE MASONRY (F'm) SHALL BE 1500 PSI.
- MORTAR SHALL MEET THE PROPERTY SPECIFICATION OF A.S.T.M. C270 TYP. "S" MORTAR AND SHALL HAVE A MINIMUM COMPRESSIVE STRENGTH OF 2000 PSI.
- GROUT SHALL MEET A.S.T.M. SPECIFICATION C475 AND HAVE A MINIMUM 28 DAY COMPRESSIVE STRENGTH OF 2000 PSI.
- CONCRETE MASONRY SHALL BE LAID IN RUNNING (COMMON) BOND.
- WALL SHALL RECEIVE TEMPORARY BRACING. TEMPORARY BRACING SHALL NOT BE REMOVED UNTIL GROUT IS FULLY CURED.

GROUNDING NOTES

- ALL GROUND ELECTRODE SYSTEMS (INCLUDING TELECOMMUNICATION, RADIO, LIGHTNING PROTECTION AND AC POWER GES'S) SHALL BE BONDED TOGETHER AT OR BELOW GRADE, BY TWO OR MORE COPPER BONDING CONDUCTORS IN ACCORDANCE WITH THE NEC.
- THE SUBCONTRACTOR SHALL PERFORM IEEE FALL-OF-POTENTIAL RESISTANCE TO EARTH TESTING (PER IEEE 1100 AND 81) FOR GROUND ELECTRODE SYSTEMS, THE SUBCONTRACTOR SHALL FURNISH AND INSTALL SUPPLEMENTAL GROUND ELECTRODES AS NEEDED TO ACHIEVE A TEST RESULT OF 5 OHMS OR LESS.
- THE SUBCONTRACTOR IS RESPONSIBLE FOR PROPERLY SEQUENCING GROUNDING AND UNDERGROUND CONDUIT INSTALLATION AS TO PREVENT ANY LOSS OF CONTINUITY IN THE GROUNDING SYSTEM OR DAMAGE TO THE CONDUIT AND PROVIDE TESTING RESULTS.
- METAL CONDUIT AND TRAY SHALL BE GROUNDED AND MADE ELECTRICALLY CONTINUOUS WITH LISTED BONDING FITTINGS OR BY BONDING ACROSS THE DISCONTINUITY WITH #6 AWG COPPER WIRE UL APPROVED GROUNDING TYPE CONDUIT CLAMPS.
- METAL RACEWAY SHALL NOT BE USED AS THE NEC REQUIRED EQUIPMENT GROUND CONDUCTOR. STRANDED COPPER CONDUCTORS WITH GREEN INSULATION, SIZED IN ACCORDANCE WITH THE NEC, SHALL BE FURNISHED AND INSTALLED WITH THE POWER CIRCUITS TO BTS EQUIPMENT.
- EACH CABINET FRAME SHALL BE DIRECTLY CONNECTED TO THE MASTER GROUND BAR WITH GREEN INSULATED SUPPLEMENTAL EQUIPMENT GROUND WIRES, 6 AWG STRANDED COPPER OR LARGER FOR INDOOR BTS; #2 AWG SOLID TINNED COPPER FOR OUTDOOR BTS.
- CONNECTIONS TO THE GROUND BUS SHALL NOT BE DOUBLED UP OR STACKED BACK TO BACK CONNECTIONS ON OPPOSITE SIDE OF THE GROUND BUS ARE PERMITTED.
- ALL EXTERIOR GROUND CONDUCTORS BETWEEN EQUIPMENT/GROUND BARS AND THE GROUND RING SHALL BE #2 AWG SOLID TINNED COPPER UNLESS OTHERWISE INDICATED.
- ALUMINUM CONDUCTOR OR COPPER CLAD STEEL CONDUCTOR SHALL NOT BE USED FOR GROUNDING CONNECTIONS.
- USE OF 90° BENDS IN THE PROTECTION GROUNDING CONDUCTORS SHALL BE AVOIDED WHEN 45° BENDS CAN BE ADEQUATELY SUPPORTED.
- EXOTHERMIC WELDS SHALL BE USED FOR ALL GROUNDING CONNECTIONS BELOW GRADE.
- ALL GROUND CONNECTIONS ABOVE GRADE (INTERIOR AND EXTERIOR) SHALL BE FORMED USING HIGH PRESS CRIMPS.
- COMPRESSION GROUND CONNECTIONS MAY BE REPLACED BY EXOTHERMIC WELD CONNECTIONS.
- ICE BRIDGE BONDING CONDUCTORS SHALL BE EXOTHERMICALLY BONDED OR BOLTED TO THE BRIDGE AND THE TOWER GROUND BAR.
- APPROVED ANTIOXIDANT COATINGS (I.E. CONDUCTIVE GEL OR PASTE) SHALL BE USED ON ALL COMPRESSION AND BOLTED GROUND CONNECTIONS.
- ALL EXTERIOR GROUND CONNECTIONS SHALL BE COATED WITH A CORROSION RESISTANT MATERIAL.
- MISCELLANEOUS ELECTRICAL AND NON-ELECTRICAL METAL BOXES, FRAMES AND SUPPORTS SHALL BE BONDED TO THE GROUND RING, IN ACCORDANCE WITH THE NEC.
- BOND ALL METALLIC OBJECTS WITHIN 6 FT. OF MAIN GROUND WIRES WITH 1-#2 AWG TIN-PLATED COPPER GROUND CONDUCTOR.
- GROUND CONDUCTORS USED IN THE FACILITY GROUND AND LIGHTNING PROTECTION SYSTEMS SHALL NOT BE ROUTED THROUGH METALLIC OBJECTS THAT FORM A RING AROUND THE CONDUCTOR, SUCH AS METALLIC CONDUITS, METAL SUPPORT CLIPS OR SLEEVES THROUGH WALLS OR FLOORS, WHEN IT IS REQUIRED TO BE HOUSED IN CONDUIT TO MEET CODE REQUIREMENTS OR LOCAL CONDITIONS, NON-METALLIC MATERIAL SUCH AS PVC PLASTIC CONDUIT SHALL BE USED. WHERE USE OF METAL CONDUIT IS UNAVOIDABLE (E.G. NONMETALLIC CONDUIT PROHIBITED BY LOCAL CODE) THE GROUND CONDUCTOR SHALL BE BONDED TO EACH END OF THE METAL CONDUIT.
- ALL GROUNDS THAT TRANSITION FROM BELOW GRADE TO ABOVE GRADE MUST BE #2 TINNED SOLID IN 3/4" LIQUID TIGHT CONDUIT FROM 24" BELOW GRADE TO WITHIN 3" TO 6" OF CAD-WELD TERMINATION POINT. THE EXPOSED END OF THE LIQUID TIGHT CONDUIT MUST BE SEALED WITH SILICONE CAULK. (ADD TRANSITIONING GROUND STANDARD DETAIL AS WELL).



ERICSSON



14708 CUSTER RD., SUITE 102
OMAHA, NE 68138
(844) 886-9377

I HEREBY CERTIFY THAT THIS ENGINEERING DOCUMENT WAS PREPARED BY ME OR UNDER MY DIRECT PERSONAL SUPERVISION AND THAT I AM A DAILY LICENSED PROFESSIONAL ENGINEER UNDER THE LAWS OF THE STATE OF OHIO

REVISIONS

REV.	DATE	BY	DESCRIPTION	QA
A	06/17/24	JA	PRELIM CD 95%	DS

SOH3567

7699 AVERY ROAD
DUBLIN, OH 43017

SGS# : 2405261

SHEET TITLE

GENERAL NOTES

SHEET NUMBER

GN-2

REVISION

0

NOTE
AC & ELECTRICAL WORK WILL NOT BE ALTERED

DISCLAIMER
THESE DRAWINGS WERE PRODUCED WITHOUT THE BENEFIT OF A CURRENT LAND SURVEY. ALL PROPERTY LINES, EASEMENTS, SETBACKS, AND DIMENSIONS SHOWN SHALL BE VERIFIED PRIOR TO START OF CONSTRUCTION. SGS TOWERS DOES NOT GUARANTEE THE ACCURACY OF SAID PROPERTY LINES, EASEMENTS, SETBACKS, AND DIMENSIONS SHOWN.



SGS
14708 CUSTER RD., SUITE 102
OMAHA, NE 68138
(844) 886-9377

I HEREBY CERTIFY THAT THIS ENGINEERING DOCUMENT WAS PREPARED BY ME OR UNDER MY DIRECT PERSONAL SUPERVISION AND THAT I AM A DAILY LICENSED PROFESSIONAL ENGINEER UNDER THE LAWS OF THE STATE OF OHIO

REVISIONS

REV.	DATE	BY	DESCRIPTION	QA
A	06/17/24	JA	PRELIM CD 95%	DS

SOH3567
7699 AVERY ROAD
DUBLIN, OH 43017
SGS# : 2405261

SHEET TITLE
OVERALL SITE PLAN

SHEET NUMBER
C-1

REVISION
0

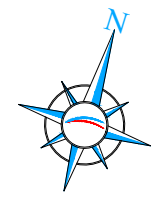
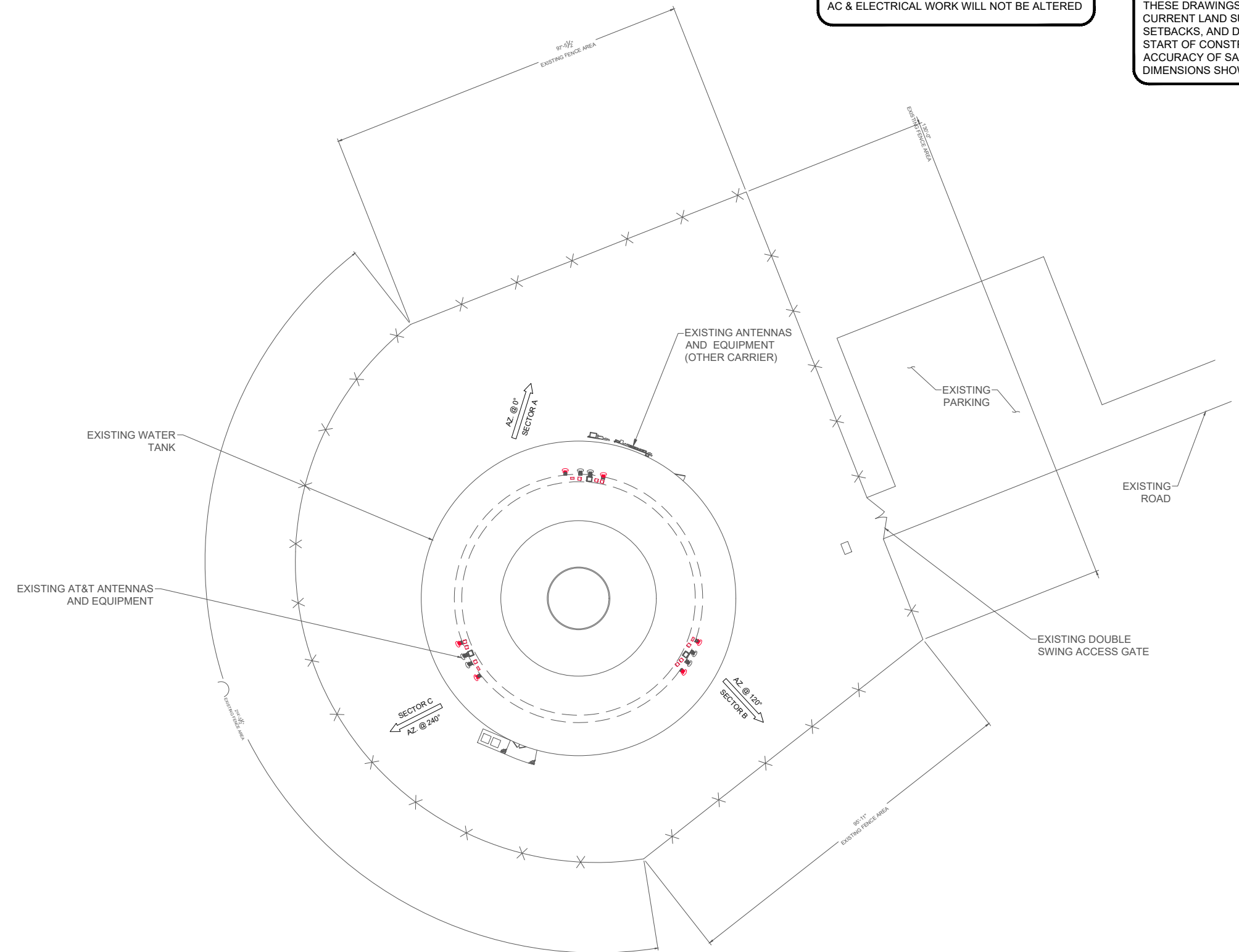

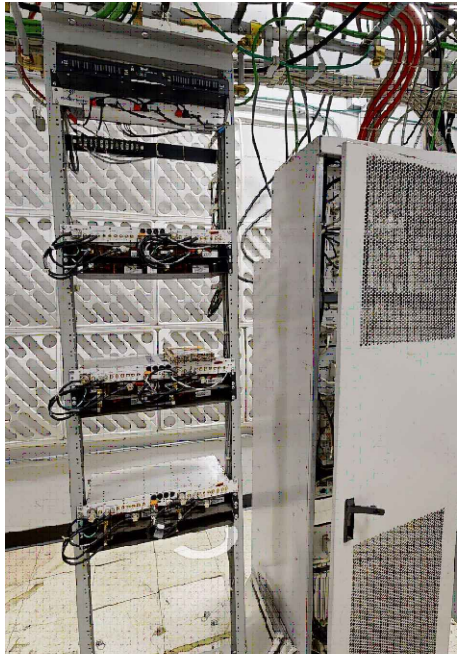
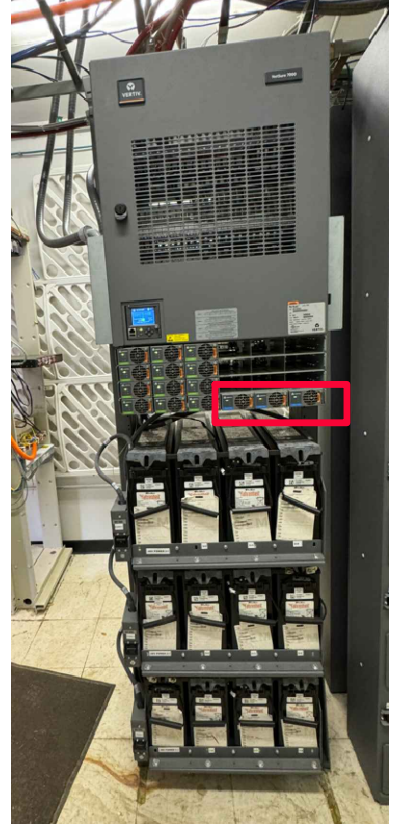
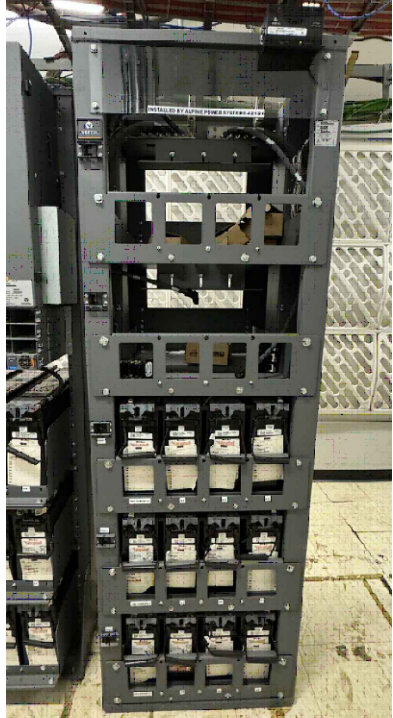
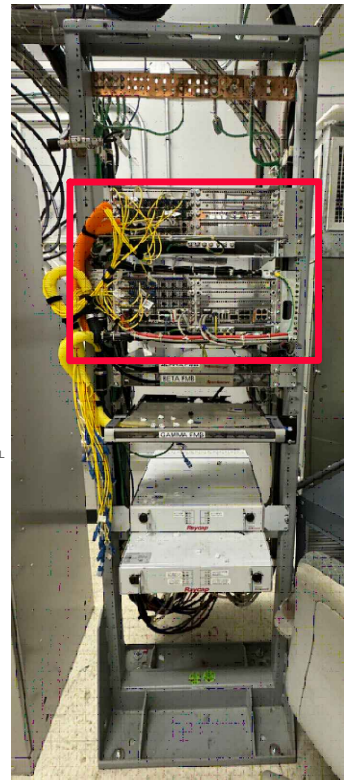
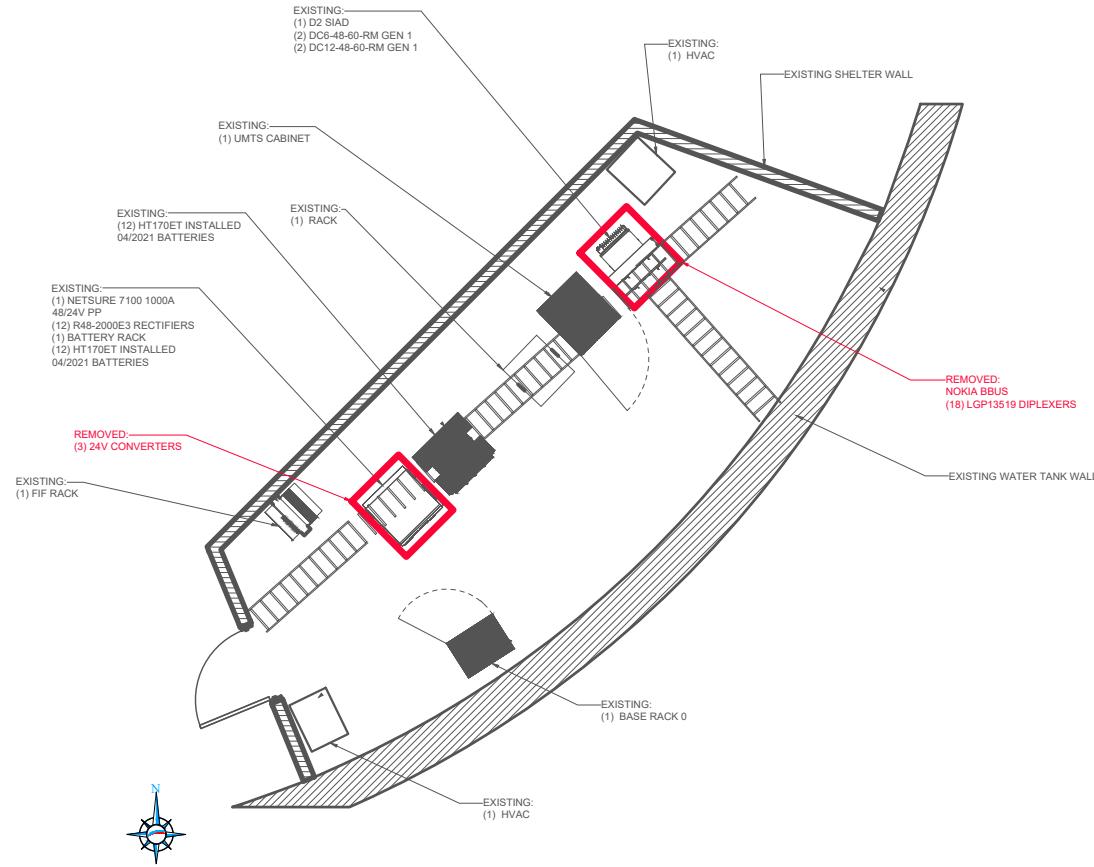

SGS
 14708 CUSTER RD., SUITE 102
 OMAHA, NE 68138
 (844) 886-9377

I HEREBY CERTIFY THAT THIS ENGINEERING DOCUMENT WAS PREPARED BY ME OR UNDER MY DIRECT PERSONAL SUPERVISION AND THAT I AM A DAILY LICENSED PROFESSIONAL ENGINEER UNDER THE LAWS OF THE STATE OF OHIO

EXISTING EQUIPMENT LAYOUT

SCALE: N.T.S. 1

REVISIONS				
REV.	DATE	BY	DESCRIPTION	QA
A	06/17/24	JA	PRELIM CD 95%	DS

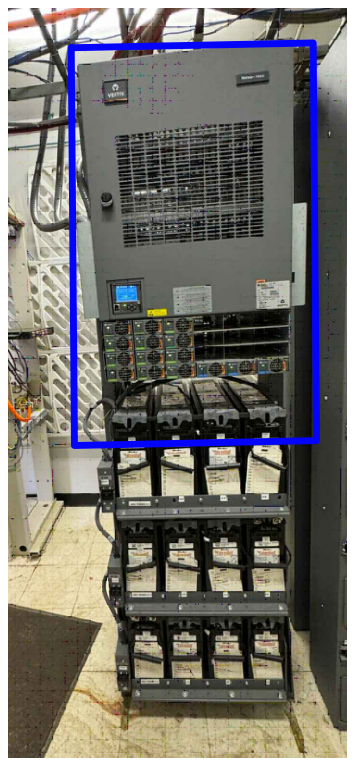
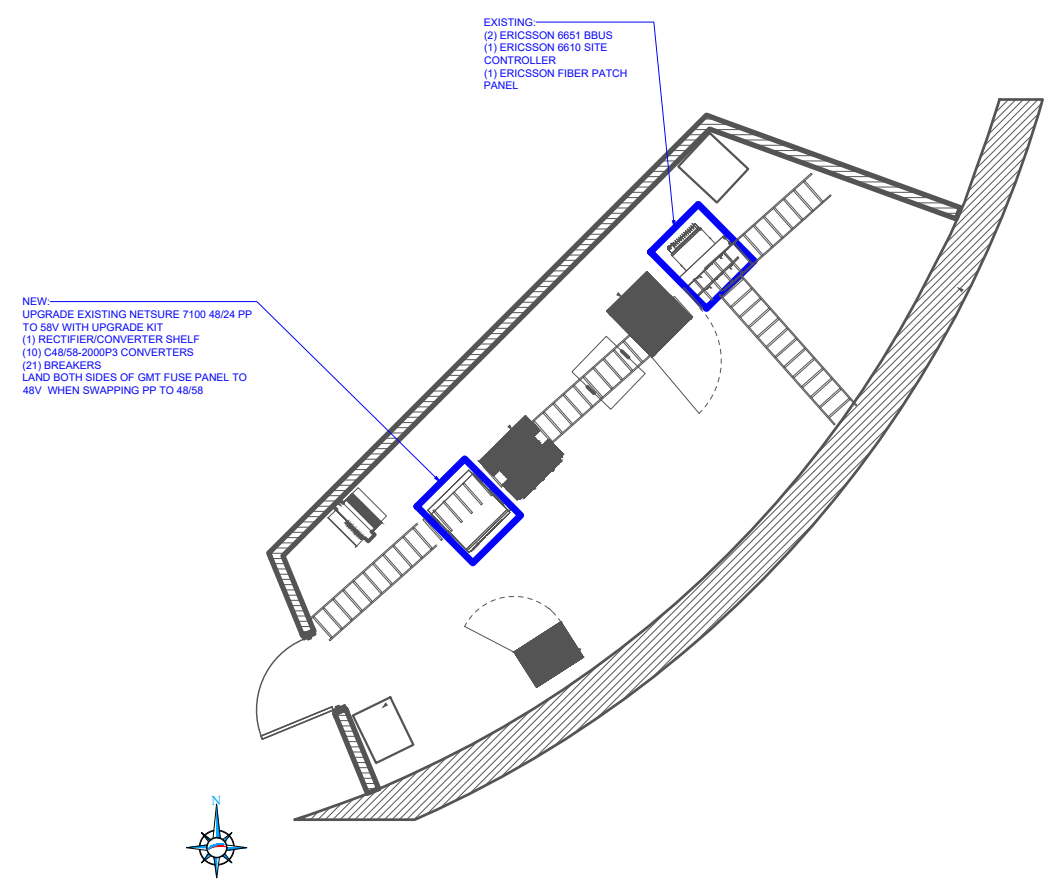

NEW EQUIPMENT LAYOUT

SCALE: N.T.S. 2

SOH3567
 7699 AVERY ROAD
 DUBLIN, OH 43017
 SGS# : 2405261

SHEET TITLE
**EXISTING & NEW
 EQUIPMENT
 LAYOUT**

SHEET NUMBER
C-2

REVISION
0

DISCLAIMER

SGS TOWERS HAS NOT PERFORMED ANALYSIS OF THE SUPPORTING STRUCTURE, AND ASSUMES NO RESPONSIBILITY FOR ITS ABILITY TO SUPPORT THE NEW MODIFICATIONS. PASSING STRUCTURAL ANALYSIS BY OTHERS IS REFERENCED IN TABLE ON T-1.



SGS
 14708 CUSTER RD., SUITE 102
 OMAHA, NE 68138
 (844) 886-9377

I HEREBY CERTIFY THAT THIS ENGINEERING DOCUMENT WAS PREPARED BY ME OR UNDER MY DIRECT PERSONAL SUPERVISION AND THAT I AM A DAILY LICENSED PROFESSIONAL ENGINEER UNDER THE LAWS OF THE STATE OF OHIO

REVISIONS

REV.	DATE	BY	DESCRIPTION	QA
A	06/17/24	JA	PRELIM CD 95%	DS

SOH3567

7699 AVERY ROAD
 DUBLIN, OH 43017

SGS# : 2405261

SHEET TITLE

STRUCTURE ELEVATIONS

SHEET NUMBER
C-3

REVISION
0

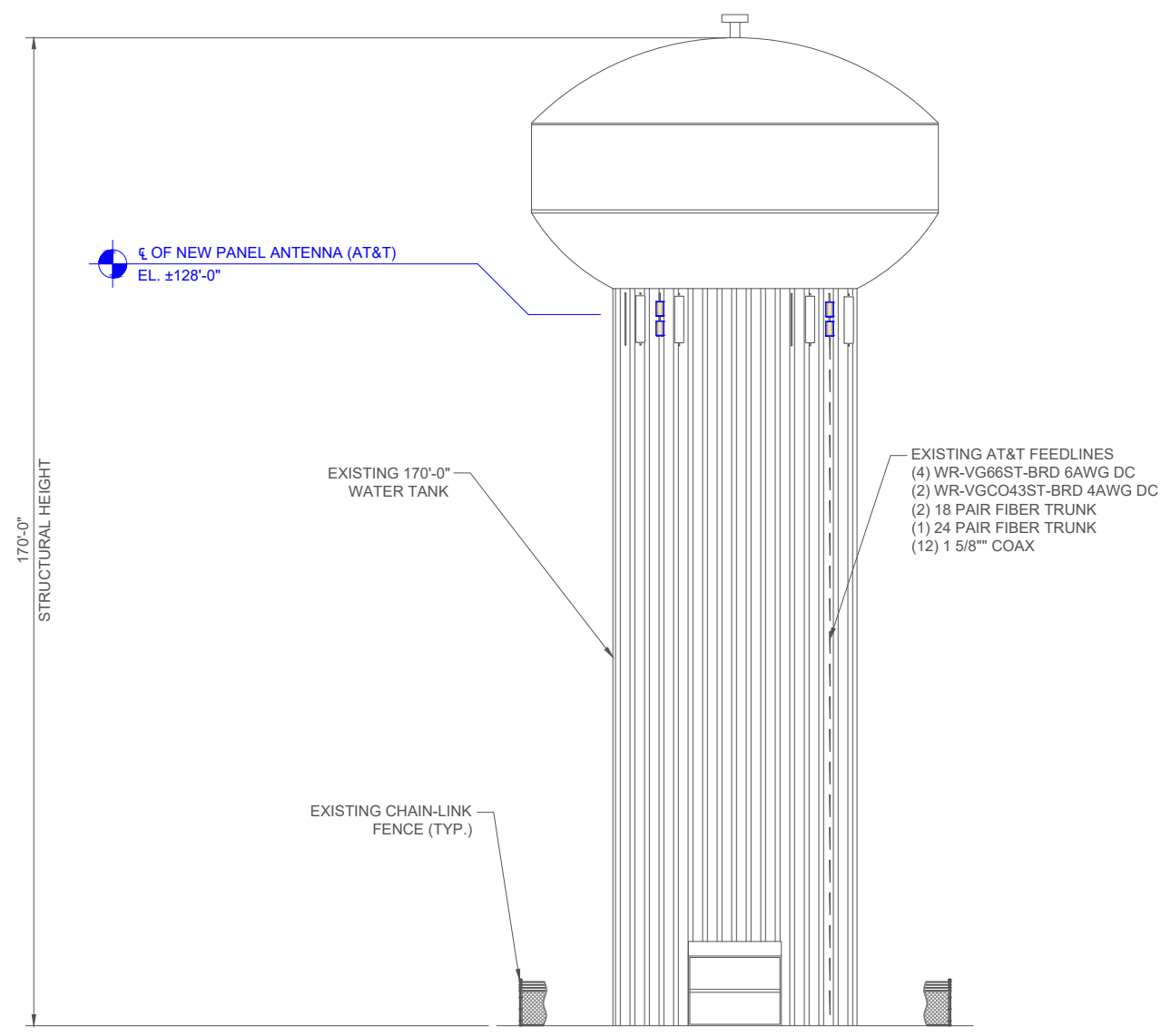
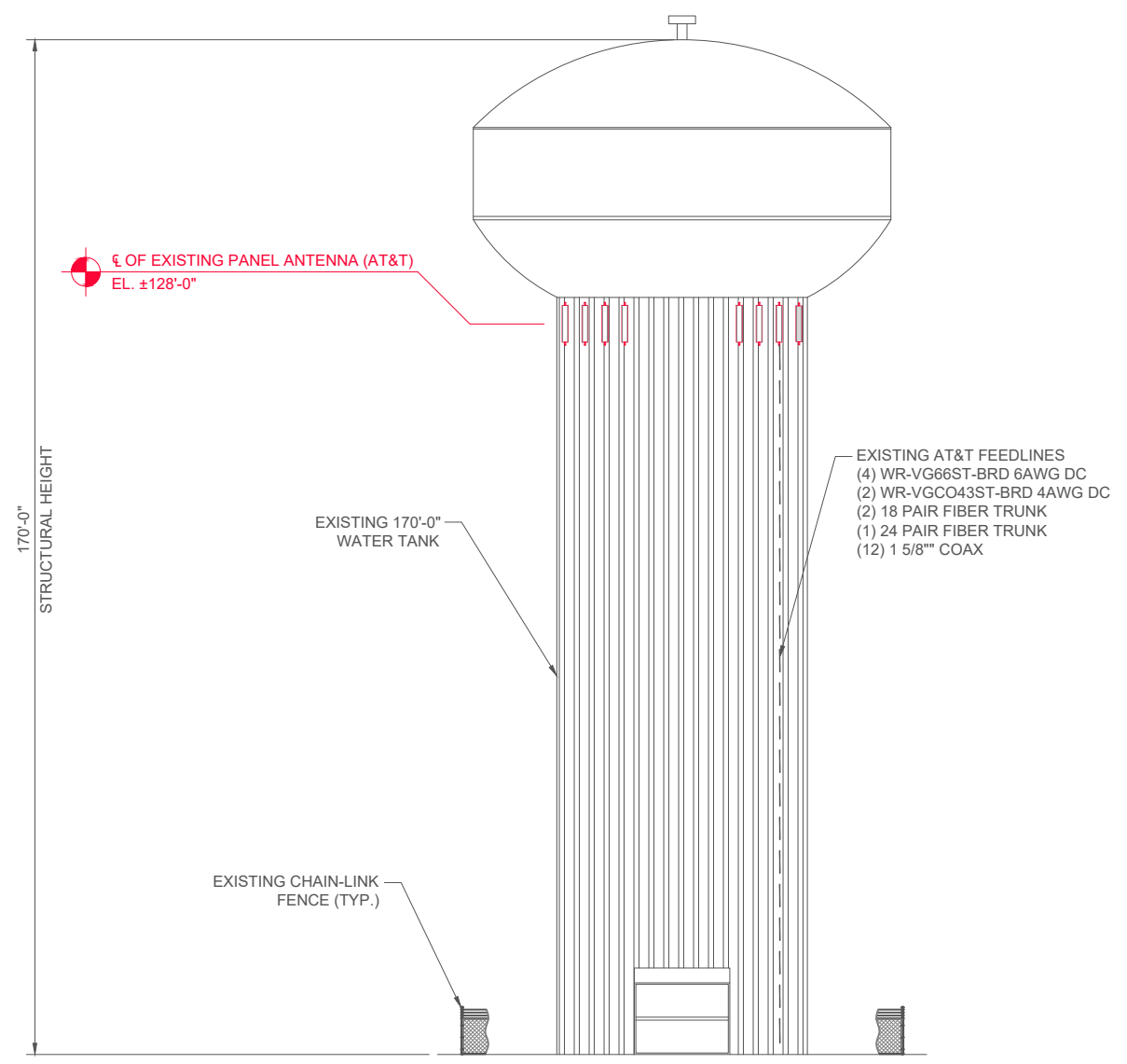

EXISTING STRUCTURE PROFILE

SCALE: 1" = 30' (11x17)

1

NEW STRUCTURE PROFILE

SCALE: 1" = 30' (11x17)

2

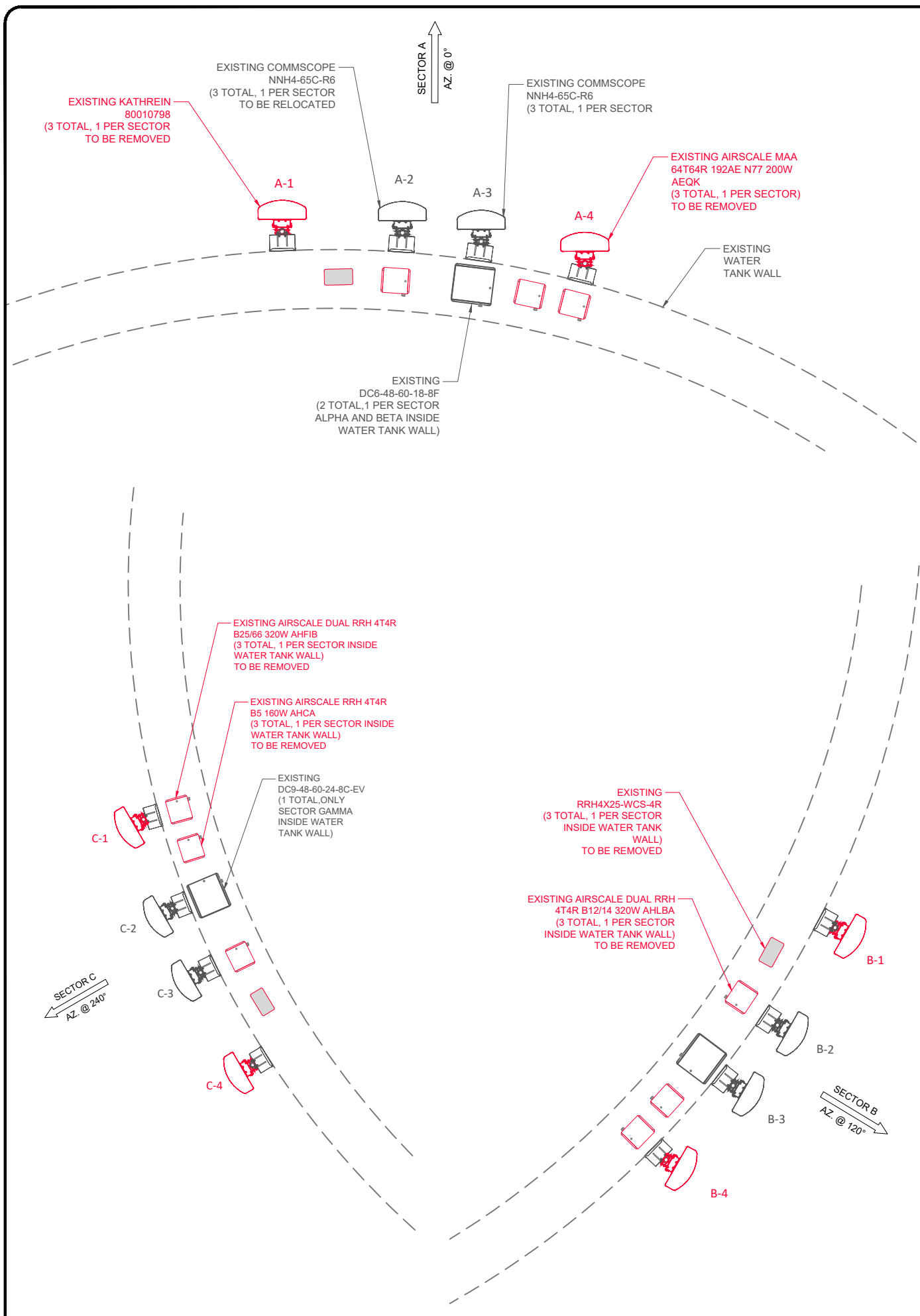

EXISTING EQUIPMENT CONFIGURATION

SCALE: 1/4" = 1'-0" (11x17)

1

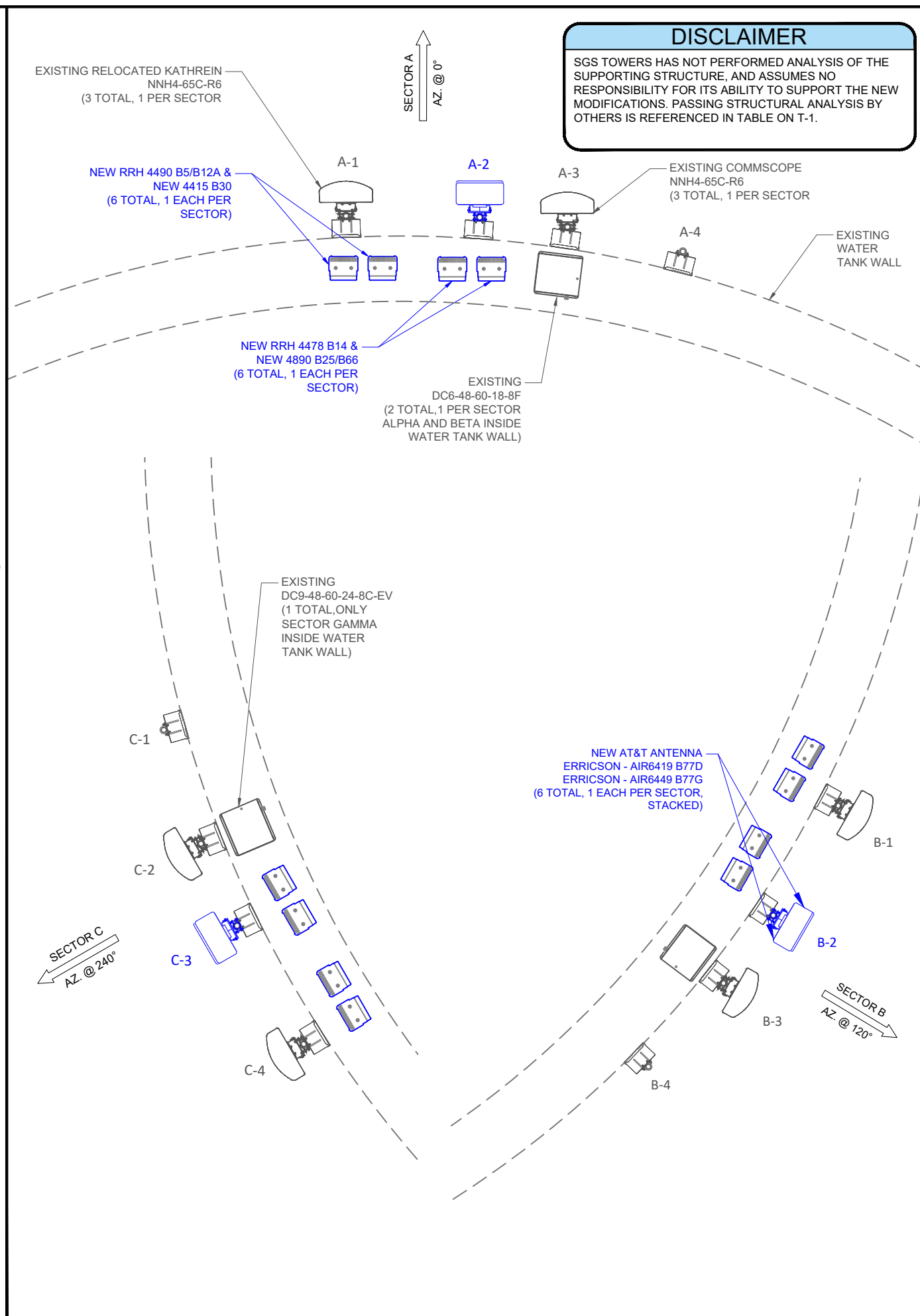

NEW EQUIPMENT CONFIGURATION

SCALE: 1" = 30' (11x17)

2

DISCLAIMER

SGS TOWERS HAS NOT PERFORMED ANALYSIS OF THE SUPPORTING STRUCTURE, AND ASSUMES NO RESPONSIBILITY FOR ITS ABILITY TO SUPPORT THE NEW MODIFICATIONS. PASSING STRUCTURAL ANALYSIS BY OTHERS IS REFERENCED IN TABLE ON T-1.



14708 CUSTER RD., SUITE 102
OMAHA, NE 68138
(844) 886-9377

I HEREBY CERTIFY THAT THIS ENGINEERING DOCUMENT WAS PREPARED BY ME OR UNDER MY DIRECT PERSONAL SUPERVISION AND THAT I AM A DAILY LICENSED PROFESSIONAL ENGINEER UNDER THE LAWS OF THE STATE OF OHIO

REVISIONS

REV.	DATE	BY	DESCRIPTION	QA
A	06/17/24	JA	PRELIM CD 95%	DS

SOH3567

7699 AVERY ROAD
DUBLIN, OH 43017

SGS# : 2405261

SHEET TITLE

**EXISTING & NEW
ANTENNA
CONFIGURATION**

SHEET NUMBER

C-4

REVISION

0



ERICSSON



14708 CUSTER RD., SUITE 102
OMAHA, NE 68138
(844) 886-9377

I HEREBY CERTIFY THAT THIS ENGINEERING DOCUMENT WAS PREPARED BY ME OR UNDER MY DIRECT PERSONAL SUPERVISION AND THAT I AM A DAILY LICENSED PROFESSIONAL ENGINEER UNDER THE LAWS OF THE STATE OF OHIO

REVISIONS

REV.	DATE	BY	DESCRIPTION	QA
A	06/17/24	JA	PRELIM CD 95%	DS

SOH3567

7699 AVERY ROAD
DUBLIN, OH 43017

SGS# : 2405261

SHEET TITLE
**EXISTING
ANTENNA &
EQUIPMENT
SCHEDULE**

SHEET NUMBER

C-5

REVISION

0

ANTENNA KEY

EQUIPMENT KEY

CABLE KEY

ANT POS.	QTY.	ANTENNA MFR.	MODEL	TYPE	RAD CENTER	AZIMUTH	DOWNTILT		STATUS	TMA			RRU			SURGE SUPPRESSION			POWER CABLES				FIBER CABLES				
							ELEC.	MECH.		QTY.	STATUS	QTY.	MODEL	STATUS	QTY.	MODEL	STATUS	QTY.	MODEL	SIZE	STATUS	QTY.	MODEL	SIZE	STATUS		
SECTOR A	A1	1	KATHREIN	80010798	PANEL	128'-0"	0°	0°	0°	0°	REMOVE			1	RRH4X25-WCS-4R	REMOVE	2	DC6-48-60-18-8F	EXISTING	4	WR-VG66ST-BRD (A/B)	-	EXISTING	2	FB-L98B-235 18 PAIRFB-L98 B-235	-	EXISTING
																	1	DC9-48-60-24-8C-EV	EXISTING	2	WR-VGCO43 ST-BRD (C)	-	EXISTING	1	FB-L98B-24 PAIRFB-L98 B-002	-	EXISTING
	A2	1	COMMSCOPE	NNH4-65C-R6	PANEL	128'-0"	0°	0°	0°		TO BE RELOCATED			1	AIRSCALE DUAL RRH 4T4R B12/14 320W AHLBA	REMOVE								12	1 5/8" COAX	-	EXISTING
	A3	1	COMMSCOPE	NNH4-65C-R6	PANEL	128'-0"	0°	0°	0°		EXISTING			1	AIRSCALE DUAL RRH 4T4R B25/66 320W AHFIB	REMOVE											
SECTOR B	A4	1	ERICSSON	AIRSCALE MAA 64T64R 192AE N77 200W AEQK	PANEL	128'-0"	0°	0°	0°		REMOVE			1	AIRSCALE RRH 4T4R B5 160W AHCA	REMOVE											
	B1	1	KATHREIN	80010798	PANEL	128'-0"	120°	0°	0°		REMOVE			1	RRH4X25-WCS-4R	REMOVE											
	B2	1	COMMSCOPE	NNH4-65C-R6	PANEL	128'-0"	120°	0°	0°		TO BE RELOCATED			1	AIRSCALE DUAL RRH 4T4R B12/14 320W AHLBA	REMOVE											
	B3	1	COMMSCOPE	NNH4-65C-R6	PANEL	128'-0"	120°	0°	0°		EXISTING			1	AIRSCALE DUAL RRH 4T4R B25/66 320W AHFIB	REMOVE											
SECTOR C	B4	1	ERICSSON	AIRSCALE MAA 64T64R 192AE N77 200W AEQK	PANEL	128'-0"	120°	0°	0°		REMOVE			1	AIRSCALE RRH 4T4R B5 160W AHCA	REMOVE											
	C1	1	KATHREIN	80010798	PANEL	128'-0"	240°	0°	0°		REMOVE			1	RRH4X25-WCS-4R	REMOVE											
	C2	1	COMMSCOPE	NNH4-65C-R6	PANEL	128'-0"	240°	0°	0°		TO BE RELOCATED			1	AIRSCALE DUAL RRH 4T4R B12/14 320W AHLBA	REMOVE											
	C3	1	COMMSCOPE	NNH4-65C-R6	PANEL	128'-0"	240°	0°	0°		EXISTING			1	AIRSCALE DUAL RRH 4T4R B25/66 320W AHFIB	REMOVE											
C4	1	ERICSSON	AIRSCALE MAA 64T64R 192AE N77 200W AEQK	PANEL	128'-0"	240°	0°	0°		REMOVE			1	AIRSCALE RRH 4T4R B5 160W AHCA	REMOVE												



ERICSSON



14708 CUSTER RD., SUITE 102
OMAHA, NE 68138
(844) 886-9377

I HEREBY CERTIFY THAT THIS ENGINEERING DOCUMENT WAS PREPARED BY ME OR UNDER MY DIRECT PERSONAL SUPERVISION AND THAT I AM A DAILY LICENSED PROFESSIONAL ENGINEER UNDER THE LAWS OF THE STATE OF OHIO

REVISIONS

REV.	DATE	BY	DESCRIPTION	QA
A	06/17/24	JA	PRELIM CD 95%	DS

SOH3567

7699 AVERY ROAD
DUBLIN, OH 43017

SGS# : 2405261

SHEET TITLE

NEW ANTENNA
& EQUIPMENT
SCHEDULE

SHEET NUMBER

C-6

REVISION

0

ANTENNA KEY

EQUIPMENT KEY

CABLE KEY

ANT POS.	QTY.	ANTENNA MFR.	MODEL	TYPE	RAD CENTER	AZIMUTH	DOWNTILT		STATUS	TMA		RRU			SURGE SUPPRESSION			POWER CABLES			FIBER CABLES						
							ELEC.	MECH.		QTY.	STATUS	QTY.	MODEL	STATUS	QTY.	MODEL	STATUS	QTY.	MODEL	SIZE	STATUS	QTY.	MODEL	SIZE	STATUS		
SECTOR A	A1	1	COMMSCOPE	NNH4-65C-R6	PANEL	128'-0"	0°	0°	0°	EXISTING			1	4490 B5/B12A	NEW	2	DC6-48-60-18-8F	EXISTING	1	WR-VG66 ST-BRD (A/B)	-	EXISTING	2	FB-L98B-23 5 18 PAIRFB-L9 8B-235	-	EXISTING	
	A2	1	ERICSSON	AIR6419 B77D	STACKED PANEL	130'-0"	0°	0°	0°	NEW																	
			ERICSSON	AIR6419 B77G		126'-0"				NEW																	
A3	1	COMMSCOPE	NNH4-65C-R6	PANEL	128'-0"	0°	0°	0°	EXISTING			1	4478 B14	NEW													
SECTOR B	A1	1	COMMSCOPE	NNH4-65C-R6	PANEL	128'-0"	120°	0°	0°	EXISTING			1	4490 B5/B12A	NEW												
	B2	1	ERICSSON	AIR6419 B77D	STACKED PANEL	130'-0"	120°	0°	0°	NEW																	
			ERICSSON	AIR6419 B77G		126'-0"				NEW																	
B3	1	COMMSCOPE	NNH4-65C-R6	PANEL	128'-0"	120°	0°	0°	EXISTING			1	4478 B14	NEW													
SECTOR C	C1	1	COMMSCOPE	NNH4-65C-R6	PANEL	128'-0"	240°	0°	0°	EXISTING			1	4490 B5/B12A	NEW												
	C2	1	ERICSSON	AIR6419 B77D	STACKED PANEL	130'-0"	240°	0°	0°	NEW																	
			ERICSSON	AIR6419 B77G		126'-0"				NEW																	
C3	1	COMMSCOPE	NNH4-65C-R6	PANEL	128'-0"	240°	0°	0°	EXISTING			1	4478 B14	NEW													

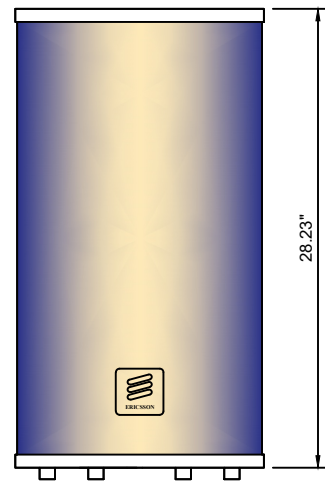

FRONT VIEW

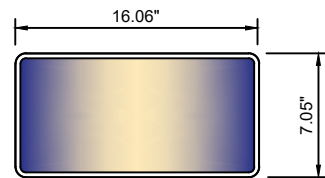

TOP VIEW

MANUFACTURER: ERICSSON
 MODEL: AIR 6419 B77D
 WEIGHT: 62.4 LBS
 SIZE (HxWxD): 28.23"x16.06"x7.05"

ERICSSON - AIR 6419 B77D

SCALE: N.T.S.

1

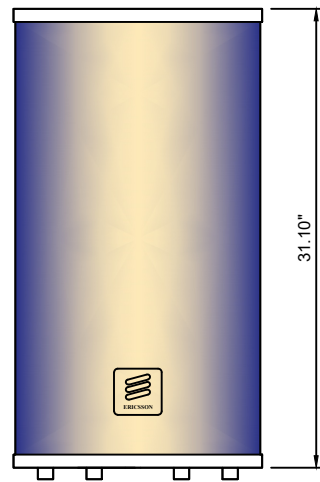

FRONT VIEW

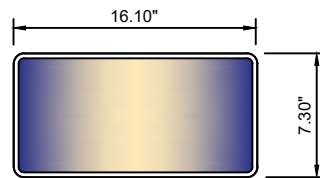

TOP VIEW

MANUFACTURER: ERICSSON
 MODEL: AIR 6419 B77G
 WEIGHT: 55.4 LBS
 SIZE (HxWxD): 31.10"x16.10"x7.30"

ERICSSON - AIR 6419 B77G

SCALE: N.T.S.

2

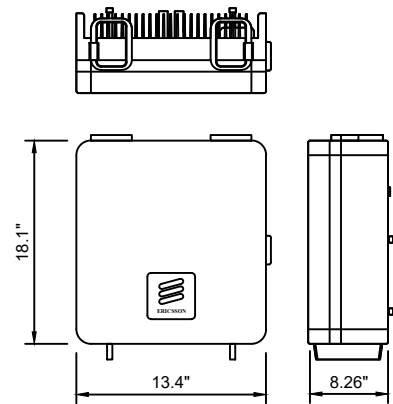

FRONT VIEW

SIDE VIEW



MANUFACTURER: ERICSSON
 MODEL: RRUS 4478 B14
 WEIGHT: 59.4 LBS
 SIZE (HxWxD): 18.1"x13.4"x8.26"

ERICSSON - RRUS 4478 B14

SCALE: N.T.S.

3



14708 CUSTER RD., SUITE 102
 OMAHA, NE 68138
 (844) 886-9377

I HEREBY CERTIFY THAT THIS ENGINEERING DOCUMENT WAS PREPARED BY ME OR UNDER MY DIRECT PERSONAL SUPERVISION AND THAT I AM A DAILY LICENSED PROFESSIONAL ENGINEER UNDER THE LAWS OF THE STATE OF OHIO

REVISIONS

REV.	DATE	BY	DESCRIPTION	QA
A	06/17/24	JA	PRELIM CD 95%	DS

SOH3567

7699 AVERY ROAD
 DUBLIN, OH 43017

SGS# : 2405261

SHEET TITLE

EQUIPMENT
 DETAILS

SHEET NUMBER

C-7

REVISION

0

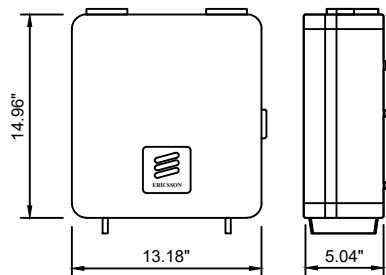
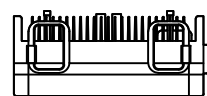

FRONT VIEW

SIDE VIEW



MANUFACTURER: ERICSSON
 MODEL: RRUS 4415 B30
 WEIGHT: 42.9 LBS
 SIZE (HxWxD): 14.96"x13.18"x5.04"

ERICSSON - RRUS 4415 B30

SCALE: N.T.S.

4

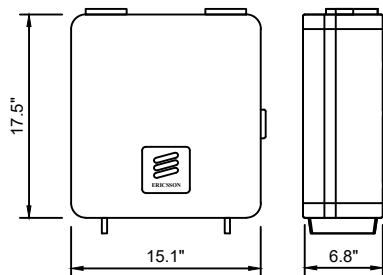

FRONT VIEW

SIDE VIEW



MANUFACTURER: ERICSSON
 MODEL: RRUS 4490 B5/B12A
 WEIGHT: 68.0 LBS
 SIZE (HxWxD): 17.5"x15.1"x6.8"

ERICSSON - RRUS 4490 B5/B12A

SCALE: N.T.S.

5

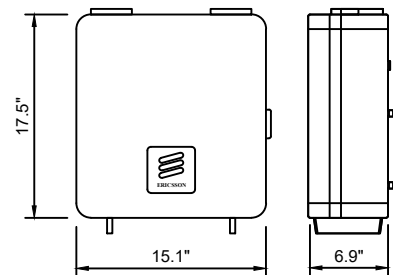

FRONT VIEW

SIDE VIEW



MANUFACTURER: ERICSSON
 MODEL: RRUS 4890 B25/B66
 WEIGHT: 68.0 LBS
 SIZE (HxWxD): 17.5"x15.1"x6.9"

ERICSSON - RRUS 4890 B25/B66

SCALE: N.T.S.

6

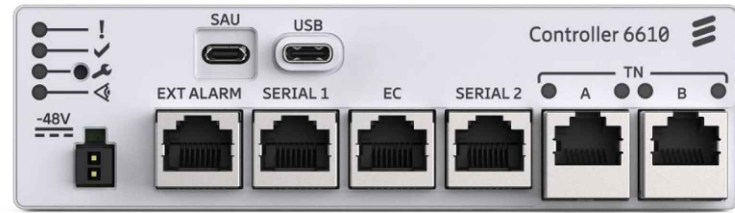

MANUFACTURER: ERICSSON
 MODEL: CONTROLLER 6610
 WEIGHT: 125.0 GRAMS
 SIZE (HxWxD): 1.57"x5.51"x1.26"

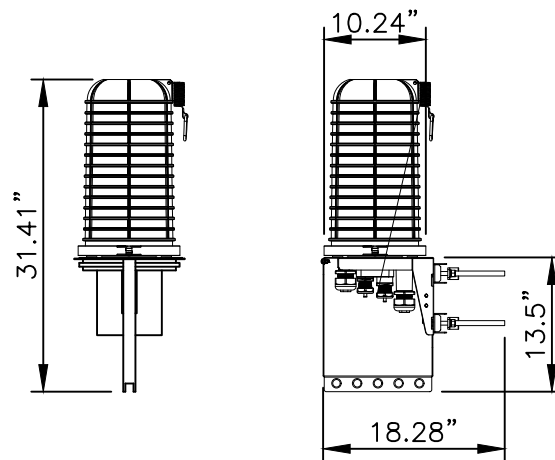

MANUFACTURER: RAYCAP
 MODEL: DC9-48-60-24-PC16-EV
 WEIGHT: 16.0 LBS
 SIZE (HxWxD): 31.40"x10.24"x18.28"

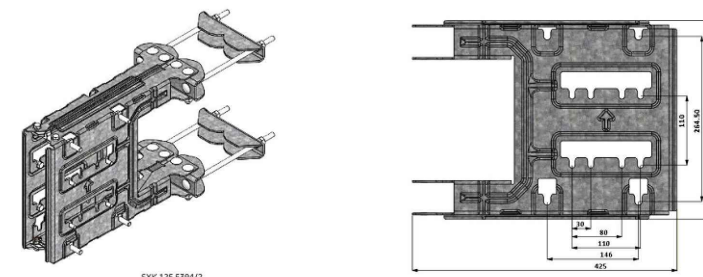

Product	Universal B2B Bracket CC110		
Product number	SXX 125 5394/2		
Mounting range	Profile	Minimum	Maximum
	Circular tube	Ø25 mm (1 inch)	Ø120 mm (4.7 inch)
	60° Angle	35 mm Opening (1.4 inch)	115 mm Opening (4.5 inch)
	90° Angle	35 x 35 mm (1.4 X 1.4 inch)	112 x 112 mm (4.4 X 4.4 inch)
	Square tube	35 x 35 mm (1.4 X 1.4 inch)	80 x 80 mm (3.1 X 3.1 inch)
Mechanical specification	Brackets	High Tensile Steel, Galvanized	
	Fasteners	Grade 8.8 Galvanized & A4	
	Bush Separators	Composite material(PBT+PET)-GF30	
Recommended tools	M8 ISO, 13mm torque wrench (10-22 Nm)		
	M10 ISO, 16mm & 17mm torque wrench (15-25 Nm)		
Performance	Maximum wind speed	67 m/s (240 km/h, 149 mph)	
	Survival wind speed	98 m/s (324 Km/h, 201 mph)	
	Maximum equipment weight	2 x 50 Kg (2 x 110.2 lbs)	

MANUFACTURER: ERICSSON
 MODEL: SXX 125 5394/2
 WEIGHT: 2x110.0 LBS



SGS
 14708 CUSTER RD., SUITE 102
 OMAHA, NE 68138
 (844) 886-9377

I HEREBY CERTIFY THAT THIS ENGINEERING DOCUMENT WAS PREPARED BY ME OR UNDER MY DIRECT PERSONAL SUPERVISION AND THAT I AM A DAILY LICENSED PROFESSIONAL ENGINEER UNDER THE LAWS OF THE STATE OF OHIO

ERICSSON - CONTROLLER 6610

SCALE: N.T.S. 1

RAYCAP - DC9-48-60-24-PC16-EV

SCALE: N.T.S. 2

ERICSSON - SXX 125 5394/2

SCALE: N.T.S. 3

REVISIONS				
REV.	DATE	BY	DESCRIPTION	QA
A	06/17/24	JA	PRELIM CD 95%	DS

SOH3567
 7699 AVERY ROAD
 DUBLIN, OH 43017
 SGS# : 2405261

SHEET TITLE
EQUIPMENT DETAILS

SHEET NUMBER
C-8

REVISION
0



MANUFACTURER: ERICSSON
 MODEL: RAN PROCESSOR 6651
 WEIGHT: 17.0 LBS
 SIZE (HxWxD): 1.73"x19.02"x15.08"



MANUFACTURER: VERTIV
 MODEL: RECTIFIER (1R482000E3)
 WEIGHT: 2.49 LBS
 SIZE (HxWxD): 1.61"x3.33"x9.94"

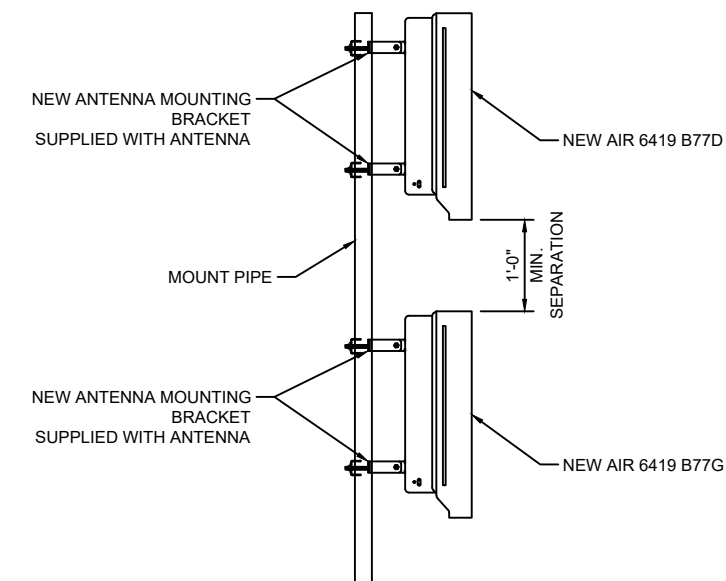

MANUFACTURER: ERICSSON
 MODEL: ANTENNA BRACKET STD.

ERICSSON - RAN PROCESSOR 6651

SCALE: N.T.S. 4

VERTIV - RECTIFIER

SCALE: N.T.S. 5

ERICSSON - AIR ANTENNA BRACKET DETAIL

SCALE: N.T.S. 6

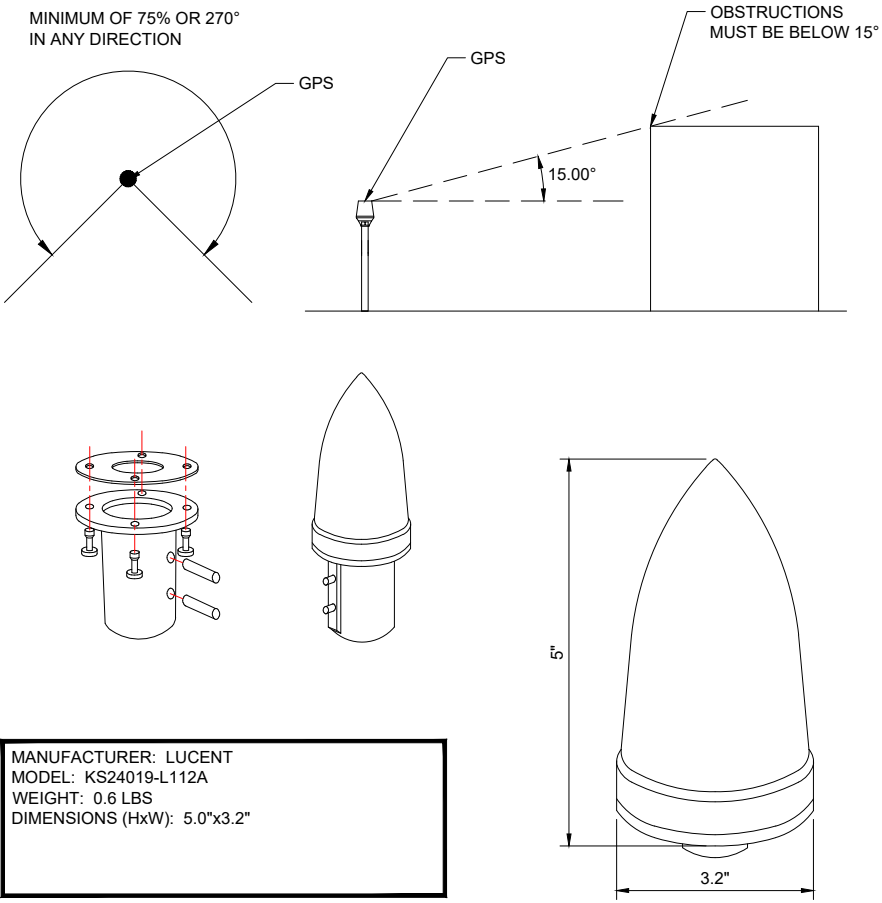

GPS DETAIL SCALE: N.T.S. 1

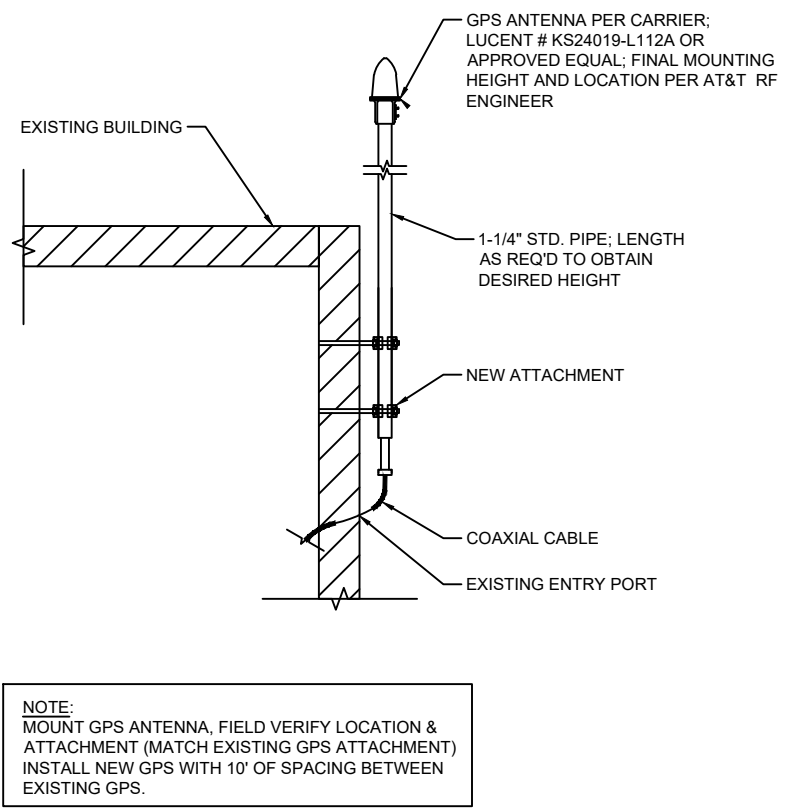

GPS MOUNTING DETAIL SCALE: N.T.S. 2



MANUFACTURER: VERTIV
 MODEL: CONVERTER(C48/58-2000P)
 WEIGHT: 2.49 LBS
 SIZE (HxWxD): 1.61"x3.33"x9.94"

VERTIV - CONVERTER SCALE: N.T.S. 3

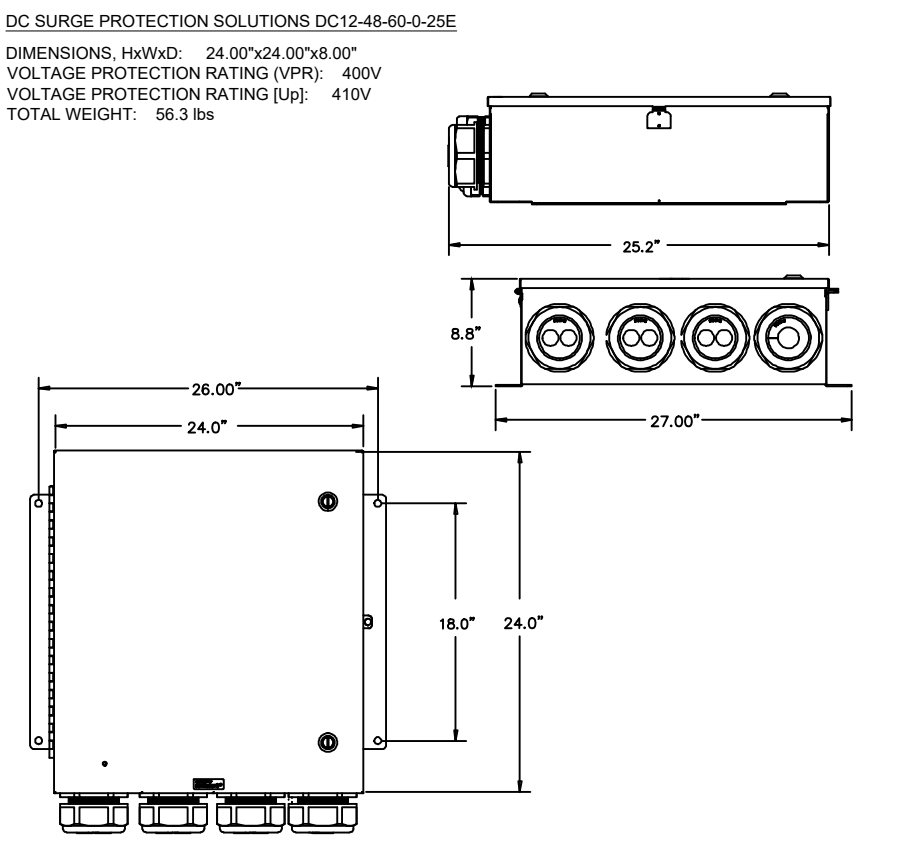

RAYCAP DC-12 SCALE: N.T.S. 4



SGS

14708 CUSTER RD., SUITE 102
 OMAHA, NE 68138
 (844) 886-9377

I HEREBY CERTIFY THAT THIS ENGINEERING DOCUMENT WAS PREPARED BY ME OR UNDER MY DIRECT PERSONAL SUPERVISION AND THAT I AM A DAILY LICENSED PROFESSIONAL ENGINEER UNDER THE LAWS OF THE STATE OF OHIO

REVISIONS				
REV.	DATE	BY	DESCRIPTION	QA
A	06/17/24	JA	PRELIM CD 95%	DS

SOH3567

7699 AVERY ROAD
 DUBLIN, OH 43017

SGS# : 2405261

SHEET TITLE

**EQUIPMENT
 DETAILS**

SHEET NUMBER

C-9

REVISION

0



ERICSSON



14708 CUSTER RD., SUITE 102
OMAHA, NE 68138
(844) 886-9377

I HEREBY CERTIFY THAT THIS ENGINEERING DOCUMENT WAS
PREPARED BY ME OR UNDER MY DIRECT PERSONAL
SUPERVISION AND THAT I AM A DAILY LICENSED PROFESSIONAL
ENGINEER UNDER THE LAWS OF THE STATE OF OHIO

REVISIONS

REV.	DATE	BY	DESCRIPTION	QA
A	06/17/24	JA	PRELIM CD 95%	DS

SOH3567

7699 AVERY ROAD
DUBLIN, OH 43017

SGS# : 2405261

SHEET TITLE

MOUNT
DETAILS

SHEET NUMBER

C-10

REVISION

0

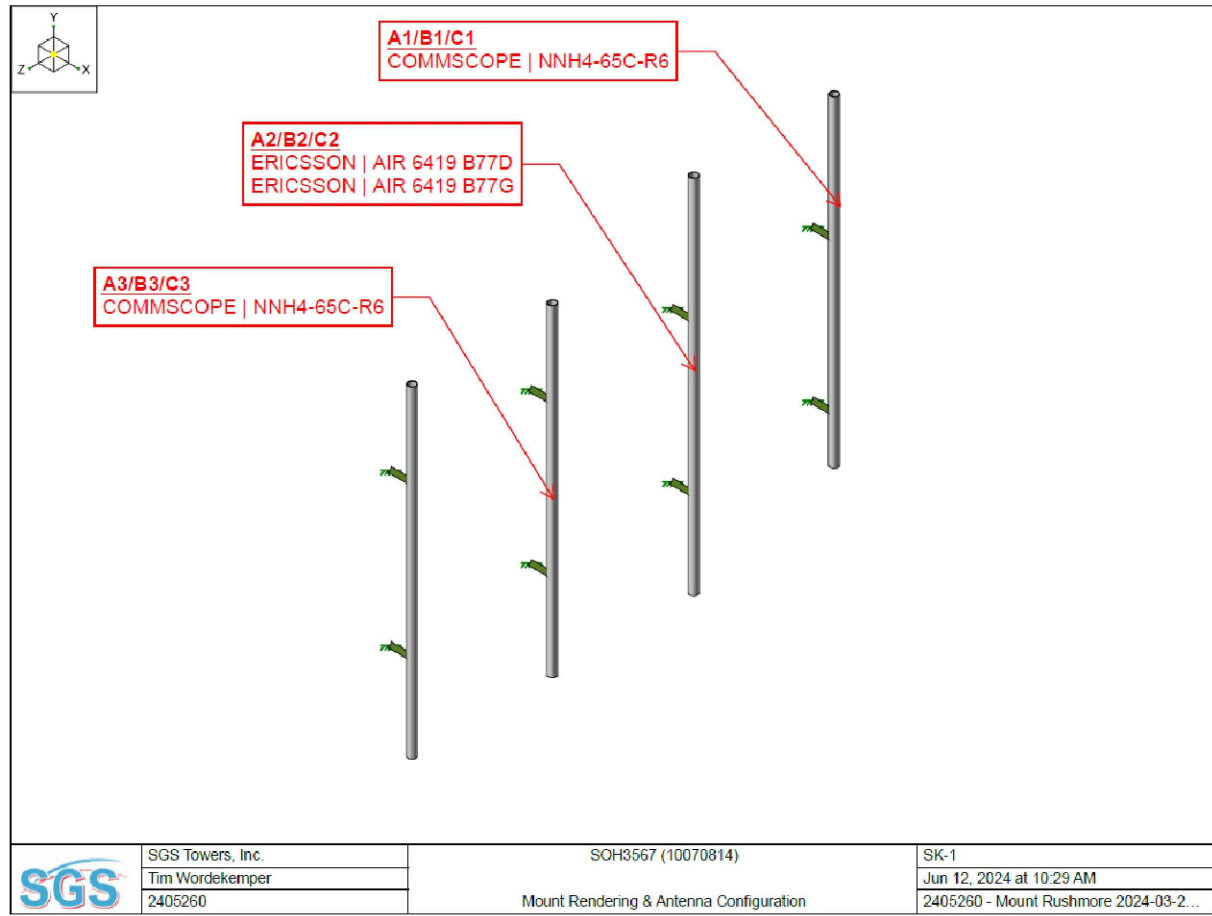

	SGS Towers, Inc.	SOH3567 (10070814)	SK-1
	Tim Wordekemper	Mount Rendering & Antenna Configuration	Jun 12, 2024 at 10:29 AM
	2405260		2405260 - Mount Rushmore 2024-03-2...



14708 CUSTER RD., SUITE 102
OMAHA, NE 68138
(844) 886-9377

I HEREBY CERTIFY THAT THIS ENGINEERING DOCUMENT WAS PREPARED BY ME OR UNDER MY DIRECT PERSONAL SUPERVISION AND THAT I AM A DAILY LICENSED PROFESSIONAL ENGINEER UNDER THE LAWS OF THE STATE OF OHIO

REVISIONS

REV.	DATE	BY	DESCRIPTION	QA
A	06/17/24	JA	PRELIM CD 95%	DS

SOH3567
7699 AVERY ROAD
DUBLIN, OH 43017
SGS# : 2405261

SHEET TITLE

PLUMBING
DIAGRAM

SHEET NUMBER

C-11

REVISION

0

Sector A

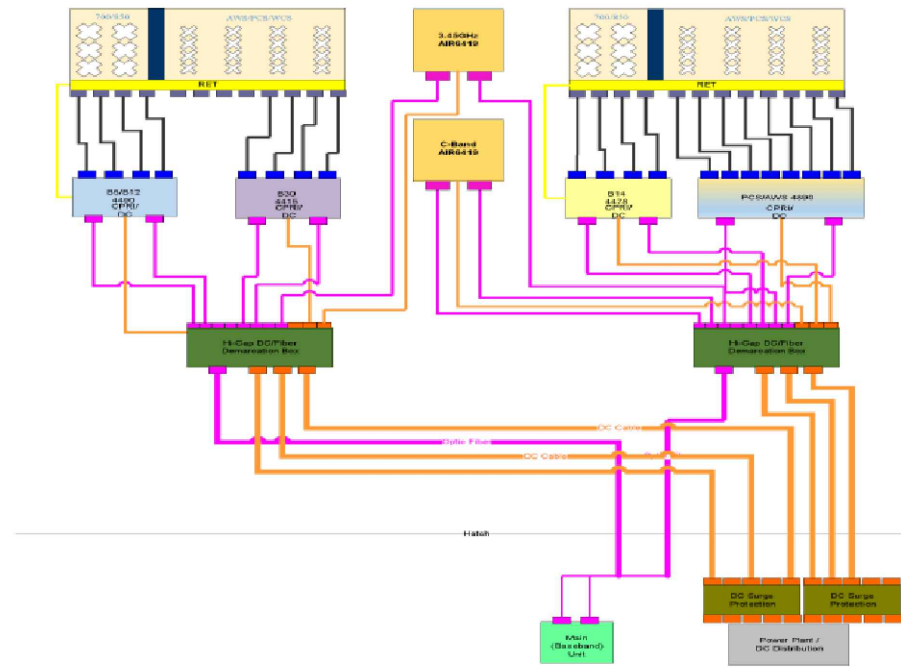

PLUMBING DIAGRAM - SECTOR A

1

Sector B

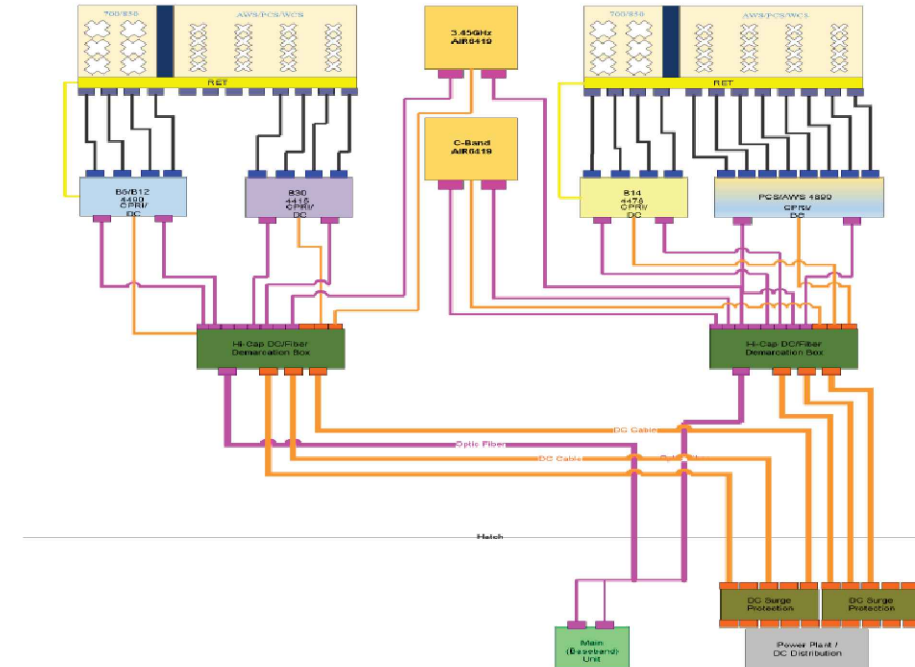

PLUMBING DIAGRAM - SECTOR B

2

Sector C

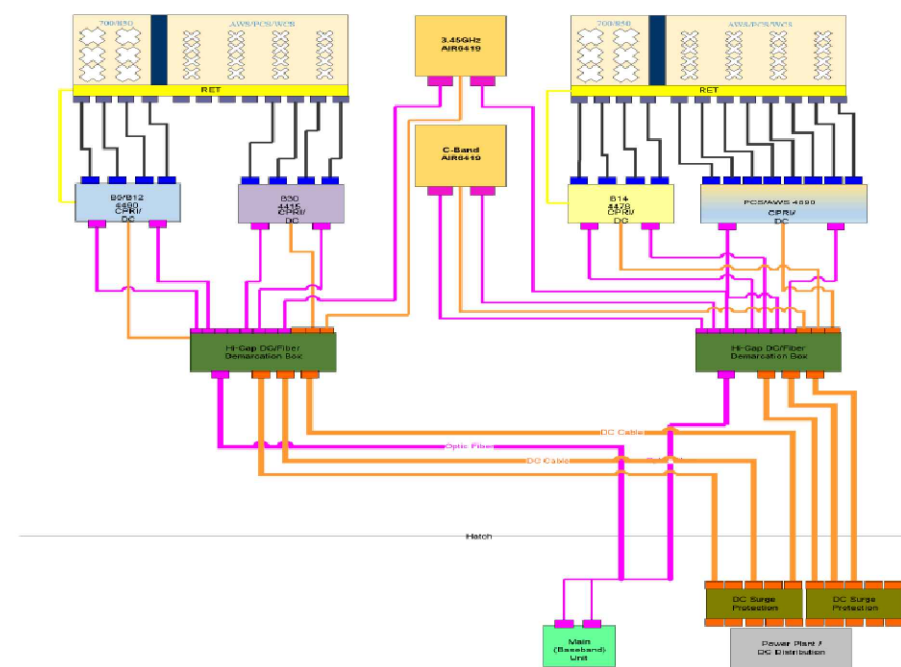

PLUMBING DIAGRAM - SECTOR C

3

NOT USED

4

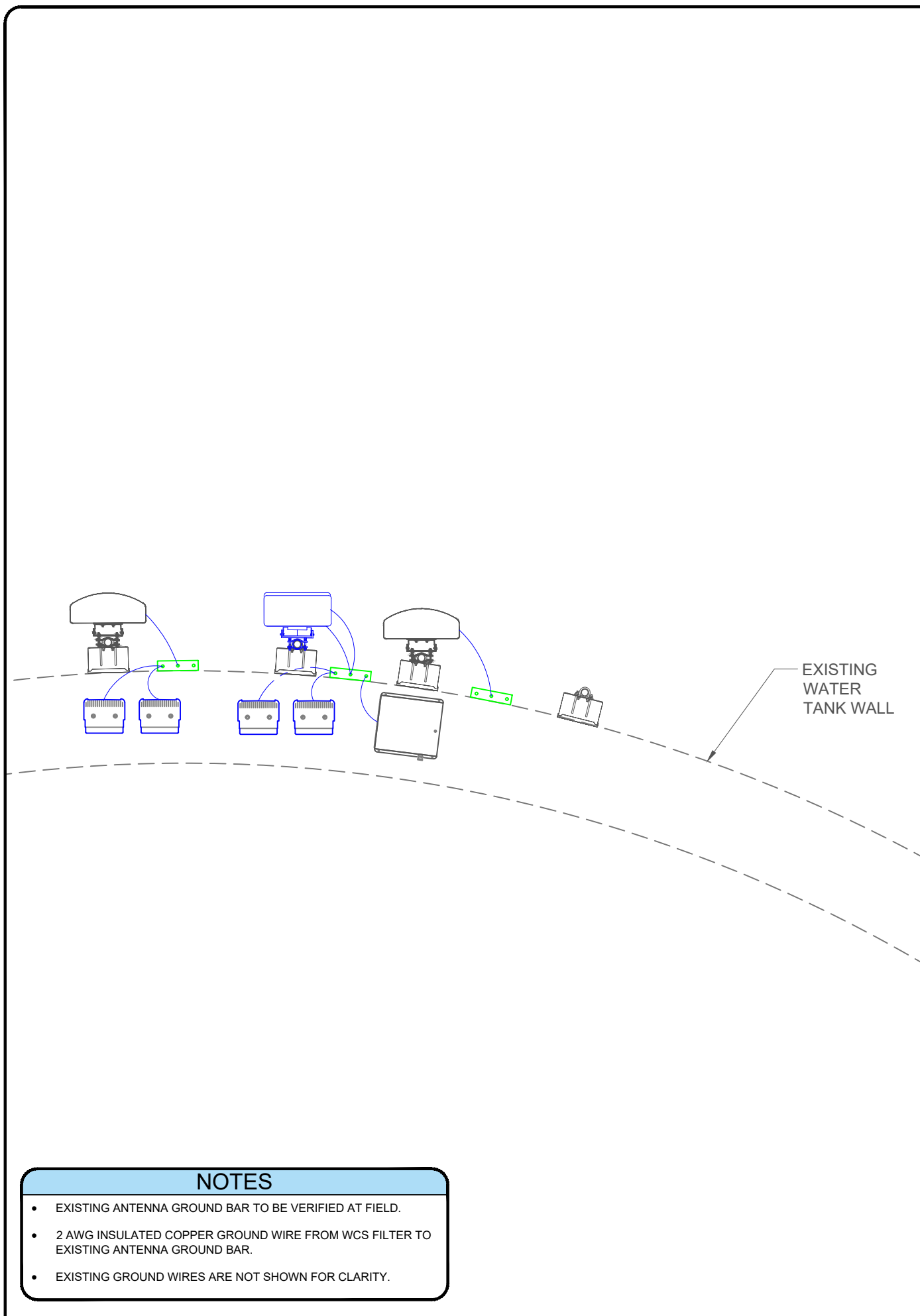

NOTES

- EXISTING ANTENNA GROUND BAR TO BE VERIFIED AT FIELD.
- 2 AWG INSULATED COPPER GROUND WIRE FROM WCS FILTER TO EXISTING ANTENNA GROUND BAR.
- EXISTING GROUND WIRES ARE NOT SHOWN FOR CLARITY.

ANTENNA GROUNDING PLAN

1

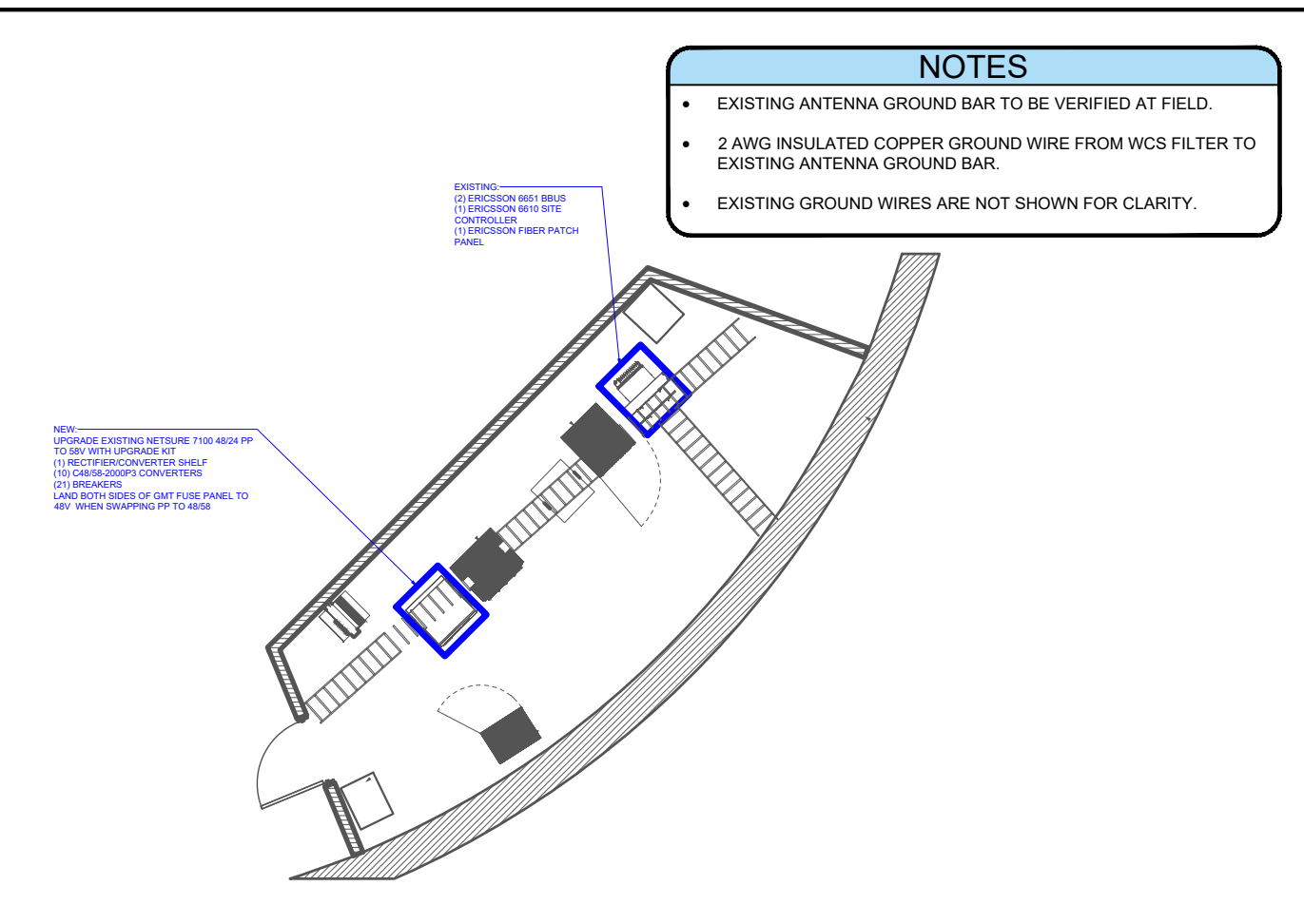

NOTES

- EXISTING ANTENNA GROUND BAR TO BE VERIFIED AT FIELD.
- 2 AWG INSULATED COPPER GROUND WIRE FROM WCS FILTER TO EXISTING ANTENNA GROUND BAR.
- EXISTING GROUND WIRES ARE NOT SHOWN FOR CLARITY.

EQUIPMENT GROUNDING PLAN

2

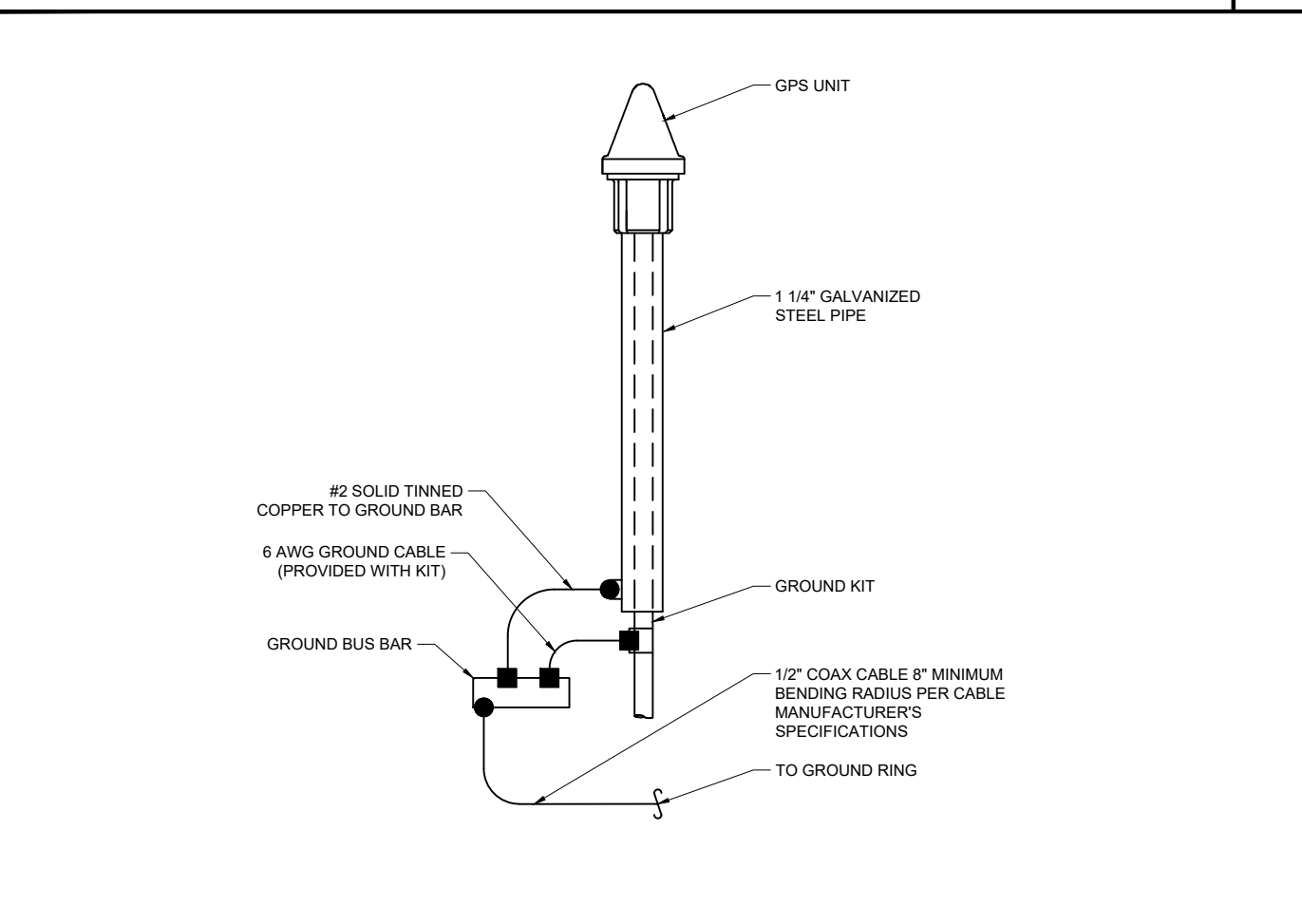

GPS ANTENNA GROUNDING DETAIL

3



SGS

14708 CUSTER RD., SUITE 102
 OMAHA, NE 68138
 (844) 886-9377

I HEREBY CERTIFY THAT THIS ENGINEERING DOCUMENT WAS PREPARED BY ME OR UNDER MY DIRECT PERSONAL SUPERVISION AND THAT I AM A DAILY LICENSED PROFESSIONAL ENGINEER UNDER THE LAWS OF THE STATE OF OHIO

REVISIONS

REV.	DATE	BY	DESCRIPTION	QA
A	06/17/24	JA	PRELIM CD 95%	DS

SOH3567

7699 AVERY ROAD
 DUBLIN, OH 43017

SGS# : 2405261

SHEET TITLE

GROUNDING DETAILS

SHEET NUMBER

G-1

REVISION

0

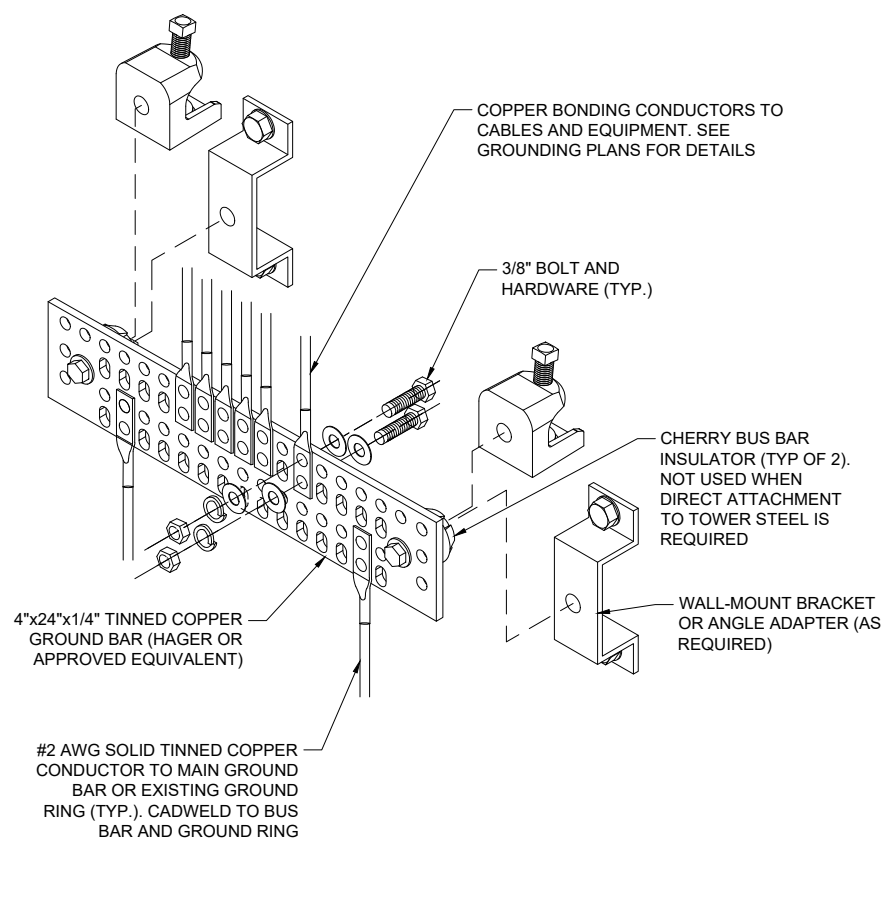

GROUNDING BAR DETAIL 1

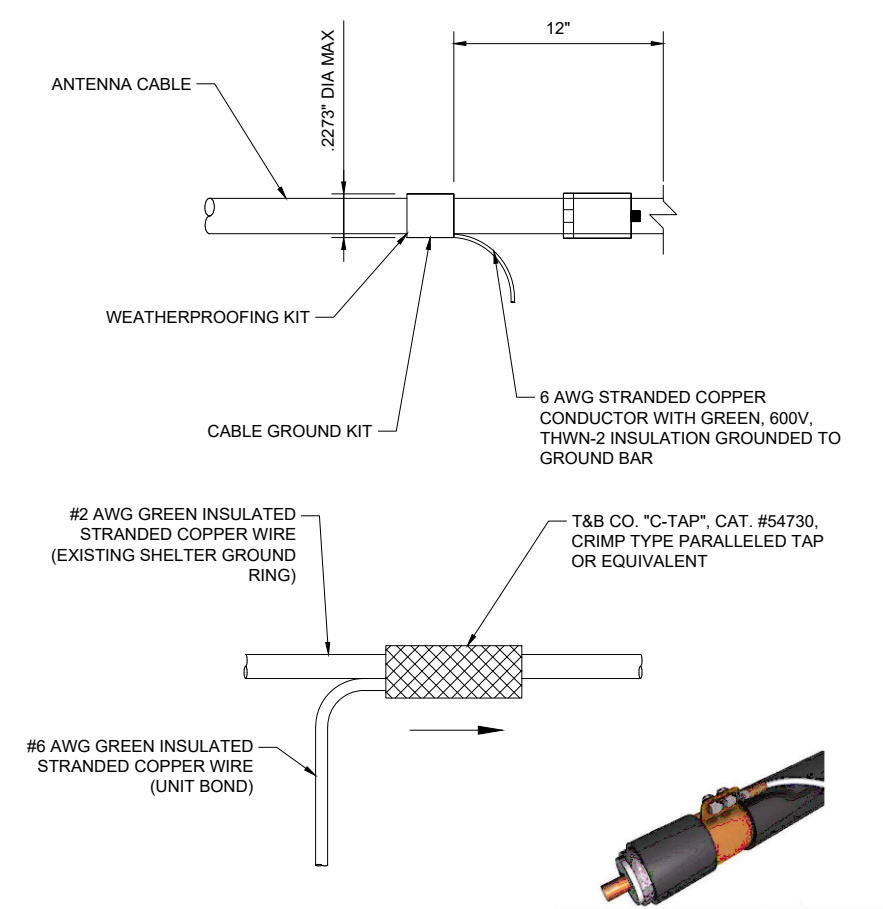

GROUNDING CONNECTIONS 2

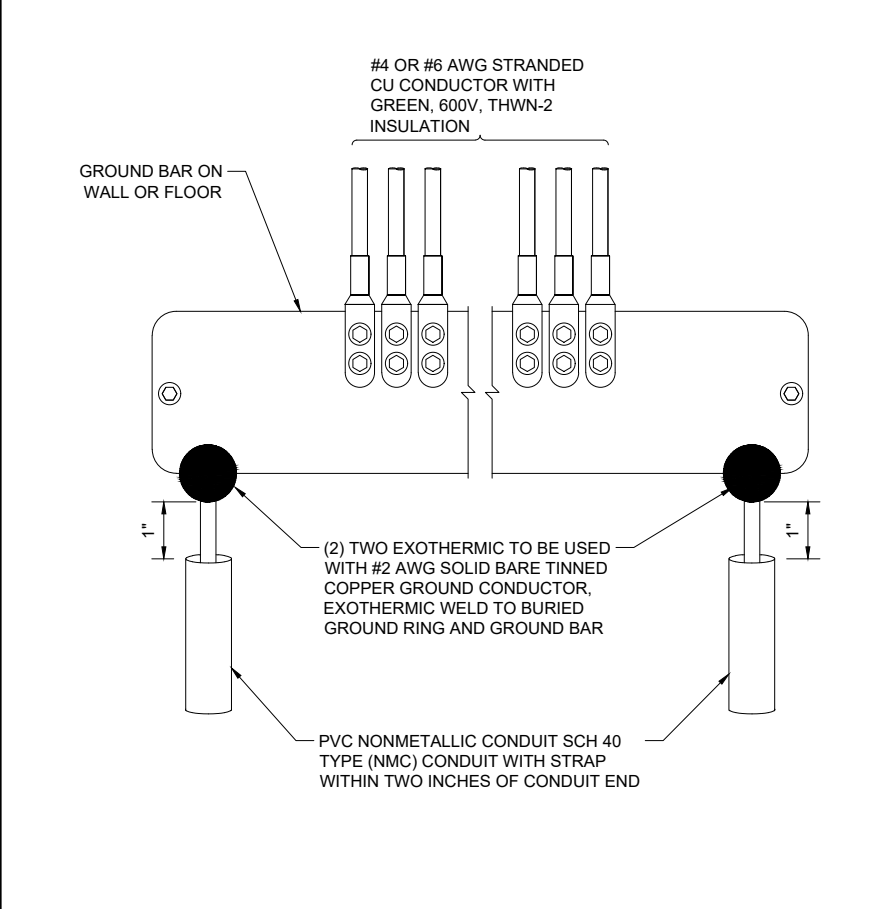

GROUNDING BAR DETAIL 3

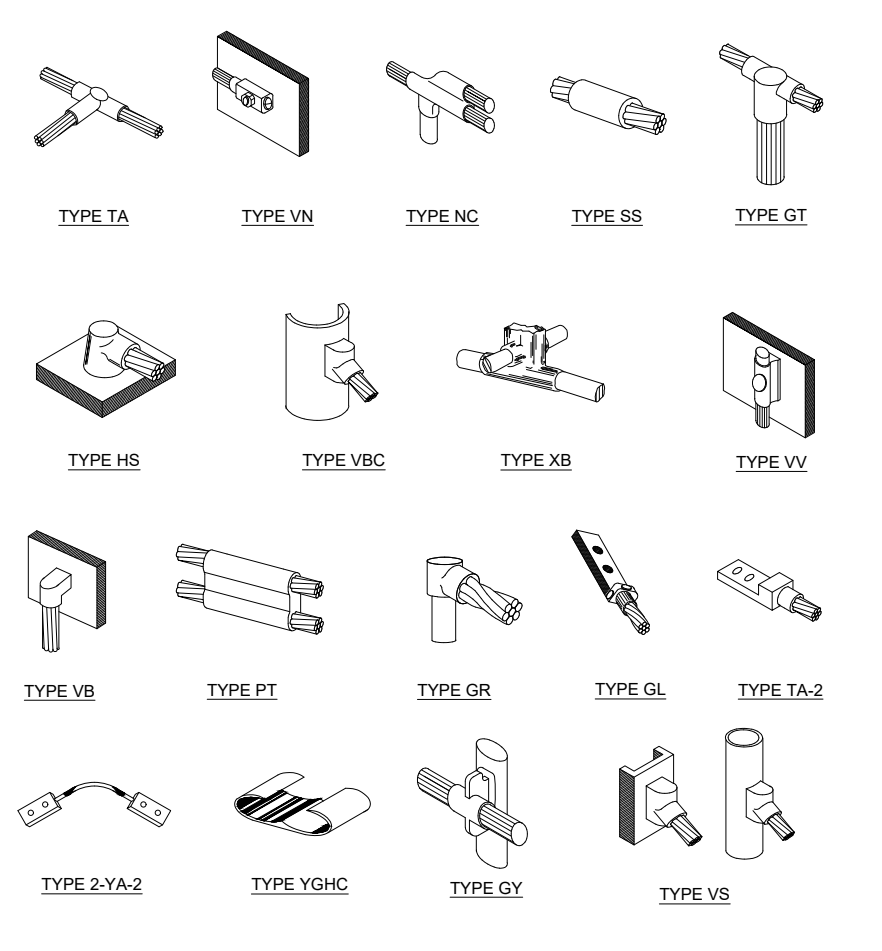

CADWELD CONNECTIONS TYPES 4



MECHANICAL CONNECTION TYPES 5

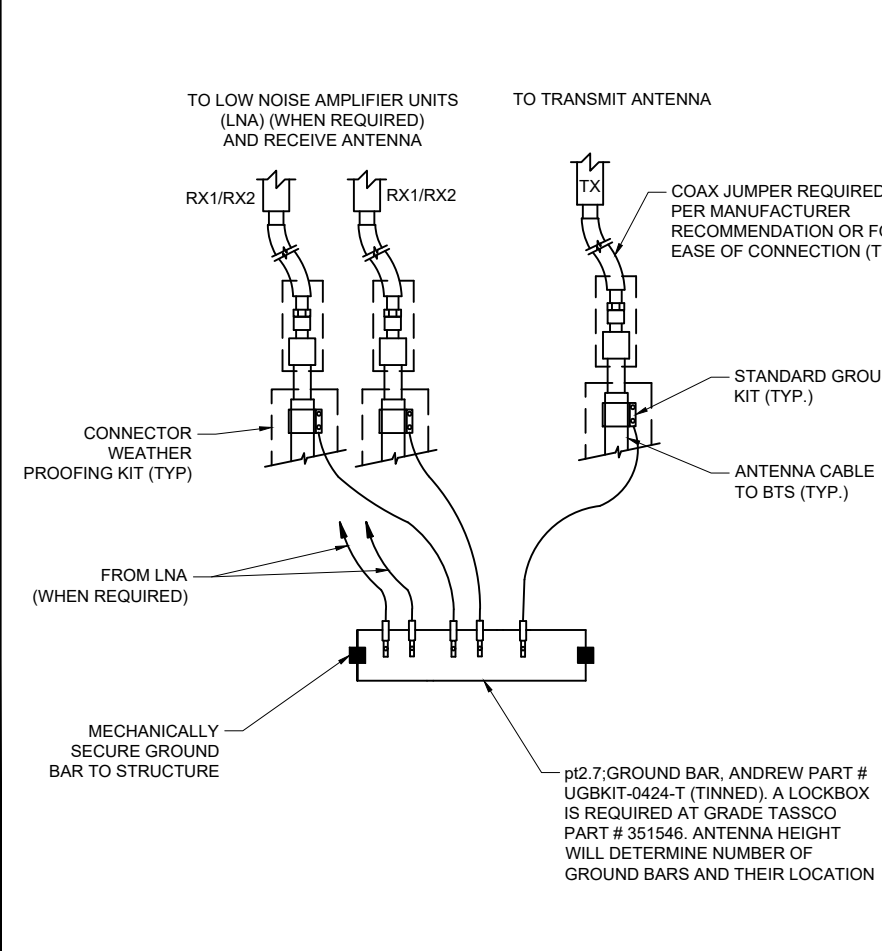

ANTENNA GROUNDING BAR DETAIL 6



I HEREBY CERTIFY THAT THIS ENGINEERING DOCUMENT WAS PREPARED BY ME OR UNDER MY DIRECT PERSONAL SUPERVISION AND THAT I AM A DAILY LICENSED PROFESSIONAL ENGINEER UNDER THE LAWS OF THE STATE OF OHIO

REVISIONS				
REV.	DATE	BY	DESCRIPTION	QA
A	06/17/24	JA	PRELIM CD 95%	DS

SOH3567
7699 AVERY ROAD
DUBLIN, OH 43017
SGS# : 2405261

SHEET TITLE
GROUNDING DETAILS

SHEET NUMBER
G-2

REVISION
0