



COHATCH RIVERVIEW
FINAL DEVELOPMENT PLAN R1
11.08.2024
© Tim Lai ArchitecT

Welcome to Riverview Village! COhatch's new National Headquarters is a one-of-a-kind coworking and entrepreneurship community.

Visible from the Link Bridge, Bridge Park, Riverside Crossing Park, North High Street, and E. Bridge Street, Riverview Village will be a new anchor for Historic Dublin.

The Riverview Village project comprises a combination of restored historic homes, a ground-up new build, and several outdoor experiences. The main goal is to revitalize the underused riverfront area by creating a modern-day village where innovative start-ups, growing small businesses, freelancers, non-profits, and hybrid companies meet and engage the community.

Building upon the popularity of the current COhatch Dublin and North High Brewing on North Street, Riverview Village will bring the community and activities even closer to the riverfront. The historic homes of 53, 45 and 37 N Riverview St will be fully restored and transformed into coworking and meeting spaces on the weekdays. Facing Riverview, the front porches of these homes will help enliven the street of North Riverview St. In the public-right-of-way to the north of 53 N Riverview, a new public plaza will become the heart of the Village. The plaza, completed with a European style kiosk vending ice cream and drinks, will encourage meaningful community engagement, serving as an entrance to the village. On weekends, the village will host arts and craft fairs, makers markets, start-up pitch competitions, public entertainment, and more, which will begin in the plaza and continue through the three historic homes and green spaces in between.

With the best view of the Link Bridge, 62 N Riverview St, commonly called the red cabin, will be restored into an original cocktail and café concept open to the public. A new deck with an enclosed addition to will be added to the North of the red cabin and a new deck with an open covered structure will be added to the East to allow for an immersive experience with nature throughout the year. An ADA-accessible route will be created through the new COhatch building to the red cabin's outdoor decks so that all can enjoy such experiences. A new staircase off N Riverview St will be constructed for

the community to access the new Riverside Crossing Park designed by MKSK. These large steps and landings will connect the park, the red cabin to the North, and the new COhatch building to the south.

The new COhatch building is proposed along the east side of N Riverview St. A total of 14,250 square feet of office and meeting spaces will be available, with the building designed to acknowledge the intimate scale and vernacular style of Historic Dublin. Stone and wood are chosen as primary building materials for their natural beauty. The multiple gable roofs and stone-clad chimneys will help break up the massing and create an undulating roof-line that fits well with the surrounding structures of the historic district. In between this new building and the red cabin, the current stairs going down east to the river will be widened. This provides access connecting the new COhatch building, the lower deck of the red cabin, and eventually the public landings to the north of the red cabin. With the two newly constructed staircases and the expanded old staircase, the community and COhatch members will be able to meander through the woods and the outdoor spaces, which are not accessible to the public currently. These will result in a highly walkable and connected Village and riverfront.

The Riverview Village is pedestrian-friendly by design. Envisioned brick-paved roads will demarcate the village premises and new sidewalks on North Street, N. Riverview St, and N. Blacksmith Ln will ensure walkability of the village. Some parking spaces are proposed along N. Riverview St for convenience and ample bike parking will be provided.

The Riverview Village presents an extraordinary opportunity for Dublin to expand its historic district, restoring and revitalizing the soul of this beloved neighborhood.

BACKGROUND

Parking Plan: **Approved**

Waivers for the use of TimberTech at decks and staircases at 62 N Riverview St and the new build: **Approved**

Waivers for the use of aluminum windows with no lintels or projecting trim at the new build and the North addition to 62 N Riverview St: **Approved**

Waivers for principal and minor roof pitch at porches, canopy, and altered/rebuilt additions at 37, 45, 53, and 62 N Riverview St: **Approved**

Waivers for the use of Pella fiberglass entry doors with traditional simulated-divided light grille with spacer between glass panes (or equivalent): **Pending approval**

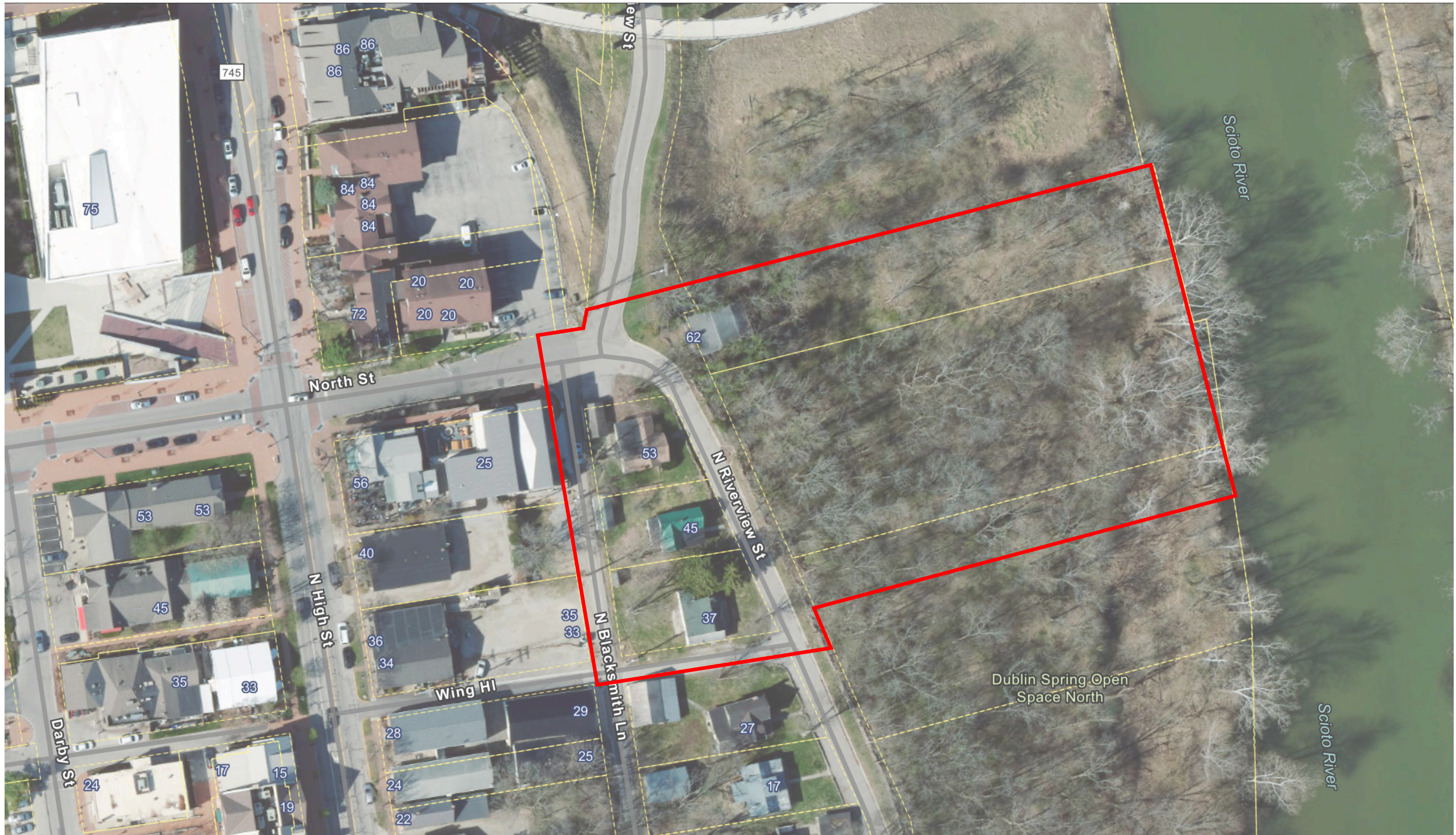

37 N RIVERVIEW ST



45 N RIVERVIEW ST



53 N RIVERVIEW ST



62 N RIVERVIEW ST



PROPOSED PLAZA LOCATION



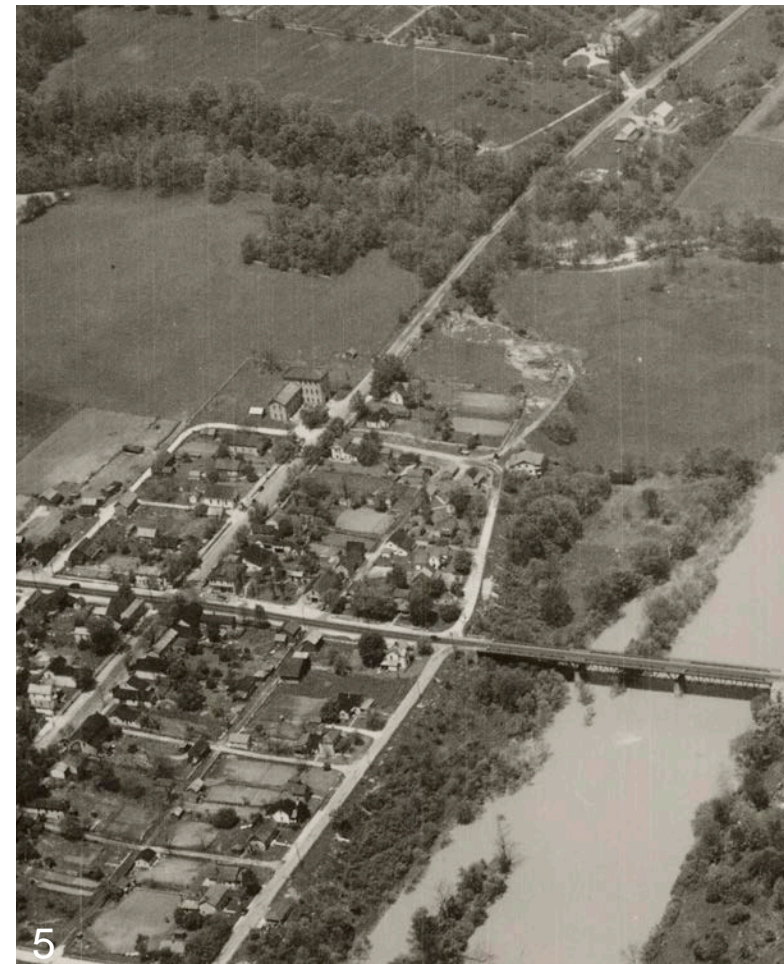

- 1 Walker's farm house on Brand Road, 1915
- 2 Cyrus Freshwater's house, circa 1900
- 3 Cook's boarding house, 83 South High St, 1903
- 4 Aerial photo of our site, 1963
- 5 Aerial photo of our site, 1929

RIVERVIEW VILLAGE OVERVIEW









COHATCH NEW BUILD



COhatch New Build

COhatch proposes a new structure of 14,250 square feet to be built on N. Riverview Street, nestled in the historic village of small-scale residential homes. This new building is two stories tall, and its massing is broken up by two gables that anchor its North and South ends. The Northern gable covers the public areas, including the entry, meeting rooms and the 2,400 square foot event space on the lower level. The Southern gable is intentionally smaller in size to echo the roofs of the surrounding homes toward the South of the village. The new build's gable silhouettes and the simple detailing of the facade are designed to subtly fit the historical context and its intimate scale. The stained wood siding with stone accents matches the general look and feel of the existing COhatch Dublin on North Street; they are also materials commonly used in the village historically.

The new build utilizes several vernacular architectural elements, such as a chimney, balcony, and pergola to fit into the village setting. These also serve as activating points for vibrant street life, reviving the mixed-use nature the village once had.

On its East facade facing the Scioto River, the new build features an outdoor deck that takes advantage of the view. This deck also connects to the deck of the red cabin, where eating, drinking, and entertainment occur and mix with the wooded riverfront.









1. Stained wood siding, medium gray to match existing COHatch

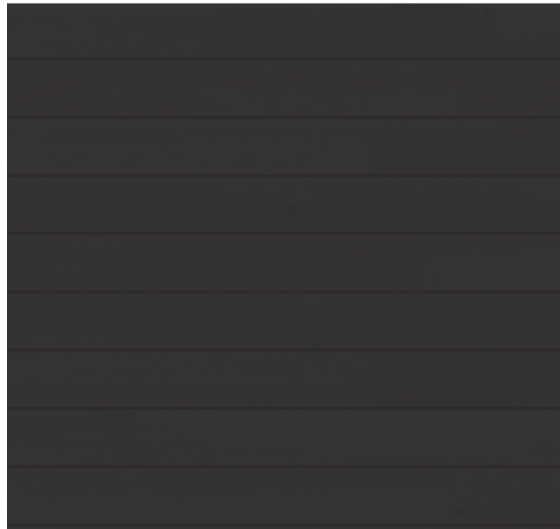

2. Stained wood siding, dark gray



3. Dark bronze metal cladding, railing, and trim



4. Limestone veneer over columns and partial foundation



5. US Formliner foundation concrete formliner 2/353 Tarn or equiv.

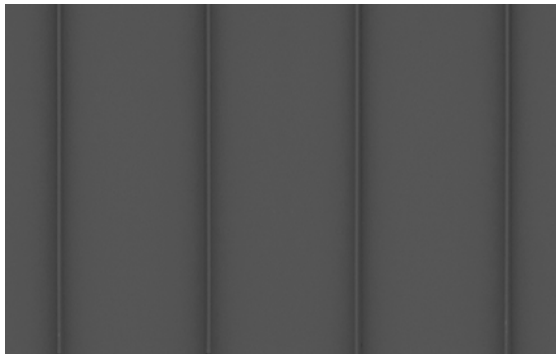

6. Standing seam metal roof, DMI Dark Bronze



7. Classic Metal Roofing Systems Oxford Shingle, Vermont Slate



8. Cedar with clear coat



9. Composite decking, BOD Timber Tech color Tigerwood

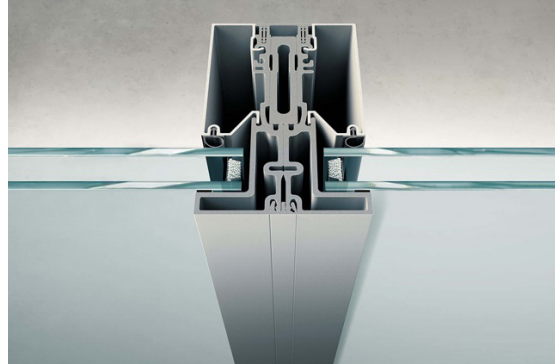

10. Aluminum window with insulated glass, dark bronze finish

New Build Wall Sconce

UGI-31591
Gino 2 Downlight



5w COB 236 Lumens
IP65 • Suitable For Wet Locations
IK07 • Impact Resistant
Weight 2.2 lbs

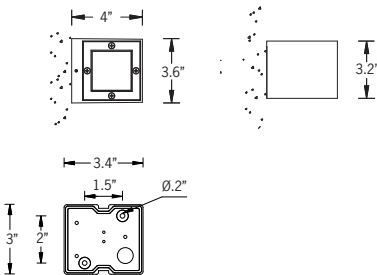

Mounting Detail

Light temperature to be
between 2700K-3000K

Construction

Aluminum
Less than 0.1% copper content – Marine Grade 6060 extruded & LM6 Aluminum High Pressure die casting provides excellent mechanical strength, clean detailed product lines and excellent heat dissipation.

Pre-paint
8 step degrease and phosphate process that includes deoxidizing and etching as well as a zinc and nickel phosphate process before product painting.

Memory Retentive –Silicon Gasket
Provided with special injection molded “fit for purpose” long life high temperature memory retentive silicon gaskets. Maintains the gaskets exact profile and seal over years of use and compression.

Thermal management
LM6 Aluminum is used for its excellent mechanical strength and thermal dissipation properties in low and high ambient temperatures. The superior thermal heat sink design by Ligman used in conjunction with the driver, controls thermals below critical temperature range to ensure maximum luminous flux output, as well as providing long LED service life and ensuring less than 10% lumen depreciation at 50,000 hours.

Surge Suppression
Standard 10kv surge suppressor provided with all fixtures.

BUG Rating
B0 - U0 - G0

Finishing
All Ligman products go through an extensive finishing process that includes fettling to improve paint adherence.

Paint
UV Stabilized 4.9Mil thick powder coat paint and baked at 200 Deg C. This process ensures that Ligman products can withstand harsh environments. Rated for use in natatoriums.

Inspired by Nature Finishes
The Inspired by nature Finishing is a unique system of decorative powder coating. Our metal decoration process can easily transform the appearance of metal or aluminum product into a wood grain finish.

This patented technology enables the simulation of wood grain, and even marble or granite finish through the use of decorative powder coating.

The wood grain finish is so realistic that it's almost undistinguishable from real wood, even from a close visual inspection. The system of coating permeates the entire thickness of the coat and as a result, the coating cannot be removed by normal rubbing, chipping, or scratching.

The Coating Process
After pre-treatment the prepared parts are powder coated with a specially formulated polyurethane powder. This powder provides protection against wear, abrasion, impact and corrosion and acts as the relief base color for the finalized metal decoration.

The component is then wrapped with a sheet of non-porous film with the selected decoration pattern printed on it using special high temperature inks.

This printed film transfer is vacuum-sealed to the surface for a complete thermo print and then transferred into a customized oven. The oven transforms the ink into different forms within the paint layer before it becomes solid. Finally, the film is removed, and a vivid timber look on aluminum remains.

Wood grain coating can create beautiful wood-looking products of any sort. There are over 300 combinations of designs currently in use. Wood grains can be made with different colors, designs, etc.

Our powder coatings are certified for indoor and outdoor applications and are backed by a comprehensive warranty. These coatings rise to the highest conceivable standard of performance excellence and design innovation.

- Added Benefits**
- Resistance to salt-acid room, accelerated aging
 - Boiling water, lime and condensed water resistant
 - Anti-Graffiti, Anti-Slip, Anti-Microbial, Anti-Scratch
 - Super durable (UV resistant)
 - TGIC free (non-toxic)

Hardware
Provided Hardware is Marine grade 316 Stainless steel.

Anti Seize Screw Holes
Tapped holes are infused with a special anti seize compound designed to prevent seizure of threaded connections, due to electrolysis from heat, corrosive atmospheres and moisture.

Crystal Clear Low Iron Glass Lens
Provided with tempered, impact resistant crystal clear low iron glass ensuring no green glass tinge.

Optics & LED
Precise optic design provides exceptional light control and precise distribution of light.
LED CRI > 80

Lumen - Maintenance Life
L80 /B10 at 50,000 hours (This means that at least 90% of the LED still achieve 80% of their original flux)

Facade-mounted building and area lighting range. Sleek, compact and expansive luminaire family with lighting packages and optics to address any need.

A range of small, square and rectangular wall mounted luminaires with options of upward or downward light distributions. Ideally suited to illuminate the wall and surfaces in front of wall and for light accents on vertical surfaces using high efficiency LED's. The Gino is suitable for indoor and outdoor applications and provides a clean, visually appealing solution for small, unobtrusive wall mounted luminaires.

This luminaire is available in 2 different sizes and in combinations of down, up or up/down light distributions. The Gino 1 and Gino 2 have a decorative spike option for added lighting effects. The Gino 1 and 2 mounts over a 3" octagonal junction box, a 4" j-box cover plate is available upon request. Frosted or clear lenses are available.

To meet International Dark Sky criteria, 3000k or warmer LEDs must be selected and luminaire fix mounted (+/- 15" allowable to permit leveling).

Additional Options (Consult Factory For Pricing)

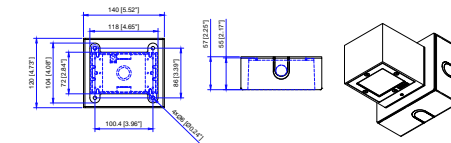

SCBT
Surface Conduit Box Trim

NOTE: This trim covers a shallow single gang surface mount junction box (Provided by contractor)
Example: Hubbell - 5322-0 - 1-Gang Weatherproof Box, Five 1/2" in. Threaded Outlets - or - 5332-0 - 1-Gang Weatherproof Box, Five 3/4 in. Threaded Outlets



New Build Composite Deck



Home > Products > Decking > TimberTech Composite™ > Legacy Collection

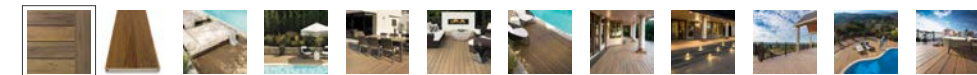

TIMBERTECH COMPOSITE
Legacy Collection

Hand-Scraped Finish

Capture the essence of nature with unique board-to-board variation (no two are exactly alike), without the rigorous maintenance of wood. Featuring a character-rich Hand-Scraped texture and dynamic blend of hues, our premium polymer capped composite boards deliver real wood aesthetics you'll never have to sand, stain, or seal.

COLOR TIGERWOOD



SAMPLE SIZE

1' Sample

FREE \$0.00

\$0.00

- 1 + ADD TO CART



DETAILS	OPTIONS & DIMENSIONS	INSTALLATION & WARRANTY	FAQS
DURABLE Made of a mix of high-performance and recycled polymers and reclaimed wood fibers, our Composite Decking is made to last and won't splinter, crack, cup, or peel.			
LOW MAINTENANCE Never sand, stain, or seal your deck ever again. An occasional scrub and rinse are all that's needed.			



New Build Metal Shingle - Vermont Slate

SLATE ROCK OXFORD

To meet the needs of homeowners who want an authentic slate appearance for their roofs, we are pleased to introduce the Slate Rock version of Oxford Shingle. This unique product combines Oxford Shingle's proven integrity with the colors and textures of high-end slate roofing.

With a focus on refined beauty, color variation, and texturing, Slate Rock offers homeowners a look that could never before be achieved in metal roofing.



Slate Rock's proprietary four-layer PVDF coating from Valspar is applied in a high definition print process that enhances Oxford Shingle's three-dimensional detail. The result is stately elegance and beauty that enhances all styles of residential architecture.

Slate Rock Oxford Shingle is truly the latest development in residential metal roofing technology, far ahead of competing products. And, it comes with our fully transferable and non-prorated Lifetime / 40-Year Limited Warranty.

Designed to the highest standards of quality and performance, Slate Rock Oxford will increase your home's beauty, value, and protection. Available in four natural slate shades.

OXFORD SHINGLE

BEAUTIFUL. DURABLE. FOR LIFE.



CLASSIC METAL ROOFING SYSTEMS
The World's Most Beautiful Metal Roof

OUR COMMITMENT TO GREEN

Classic Metal Roofing Systems is deeply committed to the stewardship of our natural resources and the environment.

- We reuse and recycle – Oxford Shingle is made from 95% post-consumer recycled aluminum. It is 100% recyclable.
- We are energy-efficient – Oxford Shingle's technologically advanced Kynar 500® or Hylar 5000® coatings – featuring Classic's Exclusive Hi-R® Heat Barrier technology – help reduce energy costs by up to 25% and reduce attic heat gain by up to 34%.
- We save for the future – Oxford Shingle can, in most cases, be installed over existing roofing materials, saving the earth from being filled with used temporary roofing.

Ask about available cool roofing tax credits and utility incentives in your area. Call us at 800-543-8938.

Proudly Manufactured in the USA.



CLASSIC METAL ROOFING SYSTEMS
The World's Most Beautiful Metal Roof

A Division of Isalah Industries, Inc.
8510 Industry Park Drive | Piqua, OH 45356
Phone: 800-543-8938 | Fax: 937-778-5116
www.classicroof.com | info@classicroof.com

It causes neighbors to stop and take a closer look. It protects your home with unparalleled strength. It understands that a cleaner planet isn't just wishful thinking, it's a necessity. And it will be around for generations. Beautiful. Durable. And definitely for life.

OXFORD SHINGLE SLATE ROCK OXFORD

VISUALLY CAPTIVATING. AGGRESSIVELY PROTECTIVE. PASSIONATELY DESIGNED.

Oxford Shingle is in a class by itself. It gives your home the beauty, durability, energy efficiency, and innovative design that no other roofing material can live up to. Oxford Shingle is designed for peak performance using only first quality aluminum, 21st century coatings, and passionate design to protect and enhance the beauty of your home.

A LIFETIME OF INSPIRATION.

There's not much left in the world that can boast a lifetime of beauty, strength, and energy efficiency like Oxford Shingle. Classic's investment grade aluminum is combined with advanced paint systems and our exclusive Hi-R® Heat Barrier Coating to reduce your home's carbon footprint. Homeowners can save up to 25% on their energy bills with Oxford Shingle. A Classic roof works hard so your climate control system works easier. In the end, your home uses less energy which keeps your costs down and reduces the strain on our nation's energy consumption.





At Classic Metal Roofing Systems, we place our 35+ years of experience, innovation, and commitment behind every roof we make. We believe in the quality of materials and designs so much that we back every shingle with our Lifetime / 40 Year Transferable Limited Warranty. The Oxford Shingle warranty will protect your home for as long as you own it and new homeowners for up to 40 years from the point of installation.

BEAUTIFUL. DURABLE. FOR LIFE.

Color. To create. To revive. To make it truly your own.

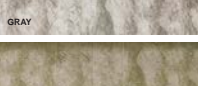
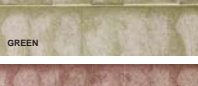

*Also available in Matte Red. Actual color may differ. Ask your Independent Classic Dealer for true color samples.

CLASSIC METAL ROOFING SYSTEMS
The World's Most Beautiful Metal Roof

New Build Standing Seam Metal Roof - Dark Bronze



ARCHITECTURAL PANEL INTER-LOCK IL20





INTER-LOCK IL20 is an architectural panel which is snapped together during installation. The panel is an integral interlocking system by design which installs in one direction from a given starting point. A double male starter panel is available (for a minimal setup fee) and may be installed in the middle of a roof area to achieve a symmetrical layout. Inter-Lock is a very flexible panel which works well with a wide range of building designs.

Uses & Applications

Product uses include roofs with slopes as low as 3:12, vertical fascia, equipment screens, mansards, and wall panels. This system may also be installed on tapered roof areas.

Advantages

- Factory Applied Non-Curing Sealant - for superior watertightness
- Engineered Snap-Together design - for easy installation
- Symmetrical Visual Aesthetics - providing non-directional appearance
- Expansion Clips - allows for thermal expansion and contraction
- Continuous Interlocking Seam - no seam disengagement
- Anti-Siphoning Seam Design - prevents water infiltration
- Continuous Roll Formed Lengths - eliminates need for panel lap joints (4' min. panel length)
- Total System Warranties available - for total confidence

INTER-LOCK IL20

Project Name: _____
Architect: _____
Installing Contractor: _____
General Contractor: _____
Specification Section: _____

Stiffener Profile _____ _____
 _____ _____

DynaClad® PVDF Color Chart

				WHITE (SR-10)	COBALT BLUE (SR-05)
PUTTY (SR-17)	SANDSTONE (SR-17)	DOVE GREY (SR-01)	PATINA COPPER (SR-10)	BRITE RED® (SR-14)	
BIDGE (SR-03)	STONE (SR-02)	SLATE GREY (SR-11)	TERRA COTTA (SR-04)	METALLIC SILVER (SR-12)	
MUSKET GREY (SR-07)	SEAPORT (SR-05)	COLONIAL RED (SR-04)	SLATE BLUE (SR-04)	CHAMPAGNE (SR-01)	
BURGUNDY (SR-04)	HEMLOCK GREEN (SR-01)	LEAF GREEN (SR-01)	CHARCOAL GREY (SR-01)	METALLIC COPPER (SR-02)	
SPARTAN BRONZE (SR-08)	CLASSIC BRONZE (SR-08)	MATTE BLACK (SR-08)	EVERGREEN (SR-08)	AGED COPPER (SR-05)	
DARK BRONZE (SR-07)	ROYAL BLUE (SR-07)	HARTFORD GREEN (SR-08)	BROWN (SR-05)	WEATHERED ZINC (SR-02)	

Custom Colors Available

Colors shown are samples and may vary slightly from actual material. Please consult DMI Color Chart for stocking color availability. †Metallic colors are directionally sensitive and therefore entire roof areas should be ordered at once time to ensure uniformity. Double Male Panel is not available in Metallic Colors. *Brite Red has a clear coat. **Premium colors carry an upcharge.

800.828.1510 • www.dmmetals.com • sales@dmmetals.com

PROVEN. DEPENDABLE. SUSTAINABLE.
METAL ENVELOPE SYSTEMS SINCE 1988



New Build Concrete Formliner



2/353 TARN

A brickwork pattern with differently-sized rocks in a natural stone look. The rough surface lends the façade a natural look.

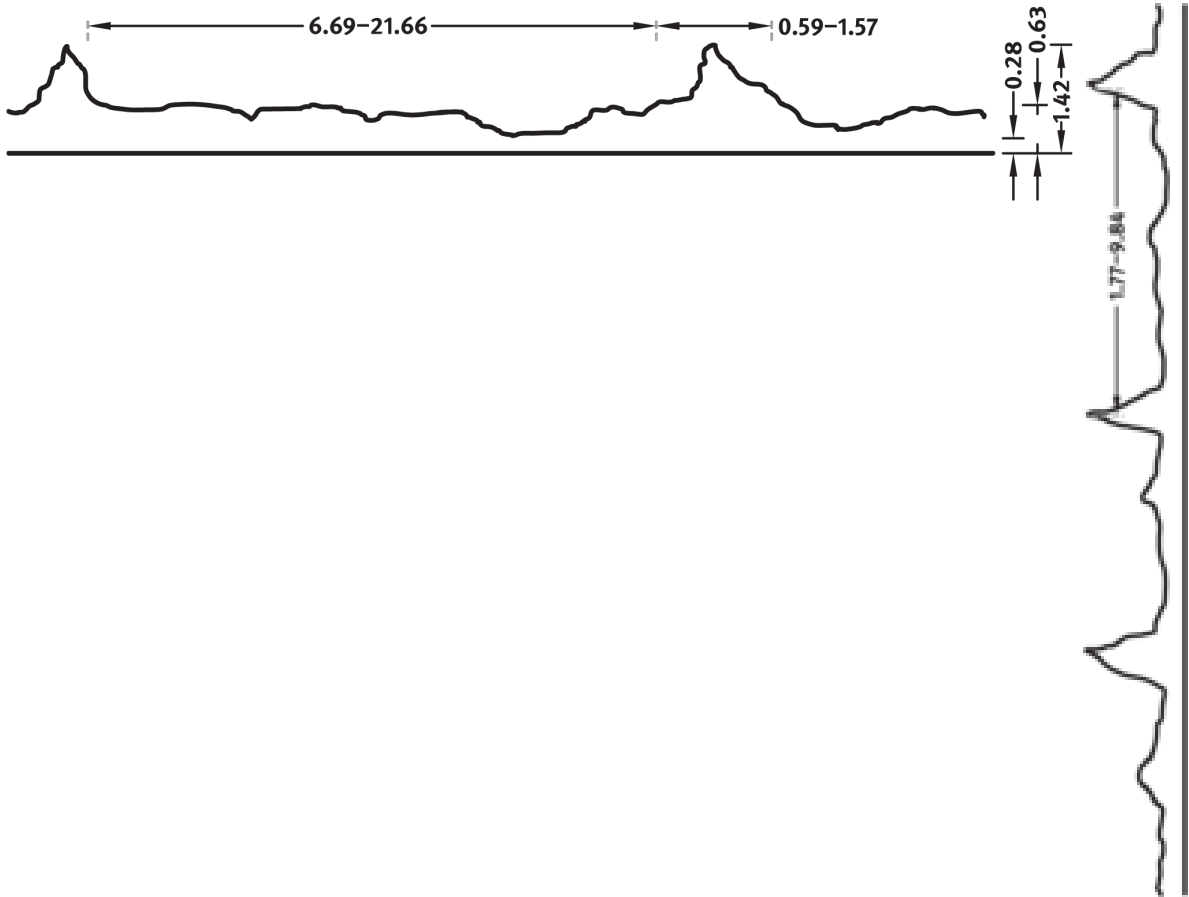

US FORMLINER HEADQUARTERS

DIMENSIONS

Uses	Dimensions (in)	Order Number
100	▲ 44.69 × ► 171.26	C 2353
10	▲ 44.69 × ► 171.26	E 2353

100-timer formliners are supplied in an individual dimension within the maximum indicated dimensions.

The specified widths of the 10-timer and 50-timer formliners are a fixed dimension and ensure the continuity of the structure in the case of linear patterns. The longitudinal direction of the pattern is variable and can be ordered from 1 m up to the maximum dimension in 10 cm steps.



PLAZA & KIOSK



Kiosk

At the center of the public plaza of Riverview Village, the kiosk stands as a magnet to attract visitors' attention. Inspired by European kiosks popular at the turn of the century, this kiosk is designed to inject a sense of the past in a magical way. Seen from the Link Bridge, this kiosk is an icon that signifies the uniqueness of Riverview Village. This dainty structure has a small footprint of less than 150 square feet, it is topped by a copper dome and roof made of the same material. The design uses traditional paneling, window trim detail and curved brackets. It has double-hung windows on three sides facing outward to the plaza where items such as ice cream, beer, and drinks are sold. During warm weather and the maker's market season, seasonal items like flowers and popsicles will be sold through mobile carts and the kiosk. Customers can also be seated at the bar-height counter at the kiosk while enjoying different beverages.







1. SW 2816 Rookwood Dark Green

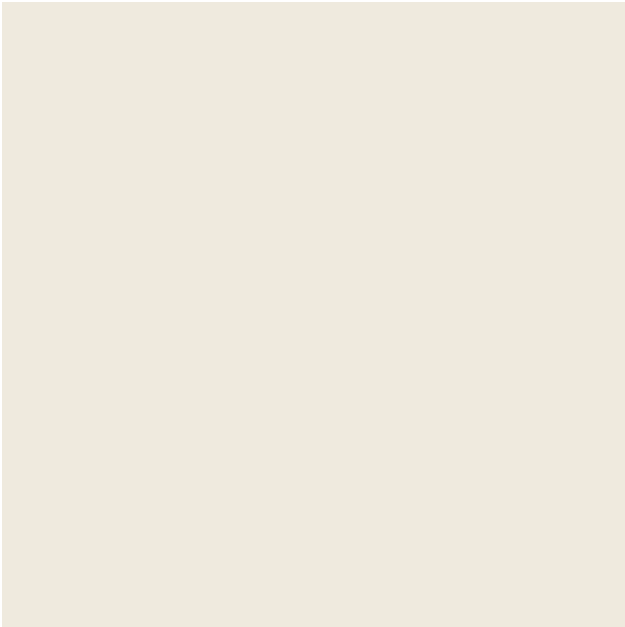

2. SW 7541 Grecian Ivory



3. Standing Seam Metal Roof -
DMI Metallic Copper



4. Classic Rock Face Block #201 - cast
concrete veneer over CMU



5. Pella Lifestyle Series aluminum clad double-hung window with 3-over-1 traditional simulated-divided-light grille and spacers between glass panes - color Iron Ore (or Andersen or equivalent)



6. James Hardie, Hardie Panel
Smooth Fiber Cement Siding



7. Daybar Delta Commercial Steel
Door painted SW 2816 Rookwood
Dark Green

Kiosk Fiber Cement Siding

Hardie® Panel Siding

Give your home exterior a fresh look with vertical panel siding available in a range of styles and textures. When combined with Hardie® Trim Batten boards, you'll achieve the rustic board-and-batten look that defines the modern farmhouse.

Showing products for: [43221](#)

Hardie® Panel

Find your style

Your home is a blank canvas. Experiment with a variety of Hardie® Panel siding styles, textures, and stunning colors featuring our ColorPlus® Technology finishes to create your masterpiece.



Individual colors may vary depending on display settings. Samples only available in Select Cedarmill® texture. Please check with your contractor or local dealer for availability in your area.

Select your siding texture



Select Cedarmill®



Smooth



Stucco



Sierra 8

Tech specs and documents

Learn everything you need to know about installing and caring for Hardie® Panel.

Specs: Select Cedarmill® +

Specs: Smooth -

Color Collection	Width	Length	Thickness	ExposureWidth
Primed for Paint ^	48.000 IN	108.000 IN	0.312 IN	36.000 IN
	48.000 IN	120.000 IN	0.312 IN	40.000 IN
	48.000 IN	96.000 IN	0.312 IN	32.000 IN

Statement Collection® v

Magnolia Home | James Hardie Collection ^

48.000 IN	120.000 IN	0.312 IN	40.000 IN
-----------	------------	----------	-----------

Dream Collection® v

* Thickness 5/16 in and Length 12 ft planks for all

Specs: Stucco +

Specs: Sierra 8 +

Kiosk Rockface Veneer

CLASSIC ROCK FACE BLOCK

#201 - Facing Block
Solid

Block	2"x8"x16" Solid
Description	Facing Block
Designs	1 2 3 4 5 6 7 8 9 10 11 12

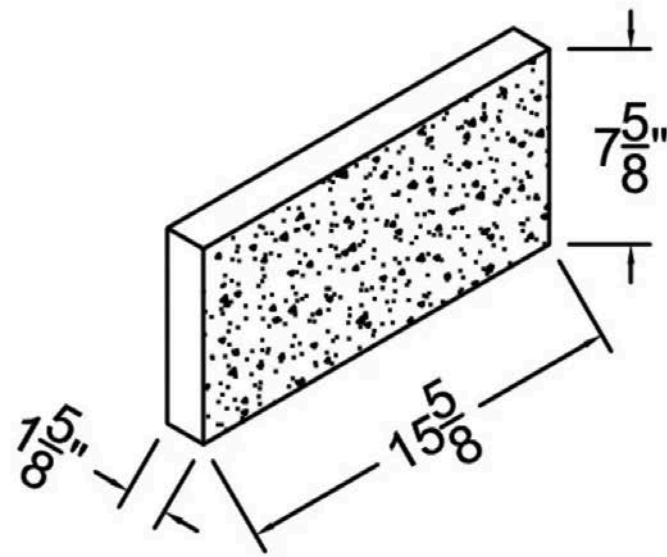

1 Sided

Designs 1,2,3,4,5,6,7,8,9,10,11,12

Kiosk Windows



PELLA® LIFESTYLE SERIES
Wood Double-Hung Window

3.94 ★★★★★☆ [2184 Reviews](#)

Pella Lifestyle Series aluminum-clad wood double-hung windows have two sashes that raise and lower for ventilation. This classic style is a great option for nearly any home — from traditional to modern. With the natural beauty of wood and the most desired features and options, double-hung windows can be customized to meet your home's unique needs.

- Dual-pane glass for excellent energy efficiency.
- Available Hidden Screen provides easy and convenient access to fresh air and natural light without compromising your view.
- Style solutions for every home with our most popular features and options, including paints, stains, grilles and more.
- Product #300001

in color Iron Ore with 3-over-1 grille

Kiosk Wall Sconce

Lightology

Ansel Outdoor Wall Sconce

SPEC #

TRY1043469



BRAND

Troy Lighting

DESCRIPTION

The Ansel Outdoor Wall Sconce features a Textured Black finish and an Opal Shiny Glass globe. This piece will bring simple style to any space and can be mounted on the wall or ceiling, indoors or out.



Shown in: Textured Black / Opal

Light temperature to be between 2700K-3000K

SHADE COLOR	Opal
BODY FINISH	Textured Black
WATTAGE	60W
DIMMER	Standard 120V
DIMENSIONS	7"W x 7"H x 6.5"D
BULB NOT INCLUDED	
LAMP	1 x A19/Medium (E26)/60W/120V Incandescent 1 x A19/Medium (E26)/120V LED

Technical Information

PRODUCT DIMENSIONS Backplate: 5.25" diameter

SPEC #

TRY1043469

Kiosk Sign Light

BSS501 | TUBULAR

Ø1-3/8" arm mount LED luminaire, remote driver

bartco
VISIONS BROUGHT TO LIGHT™

Project: _____

Type: _____

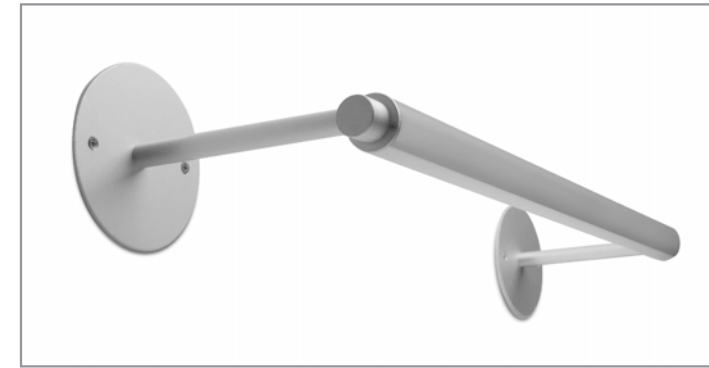

FEATURES

Part of the Tubular family of LED luminaires, the BSS501 is an arm mounted model ideally suited for wall wash and stack lighting. Slender aluminum arms project the Ø1-3/8" extruded aluminum housing from a wall or ceiling, while machined aluminum couplers allow a generous range of rotation for flexible aiming. The BSS501 is fitted with 90+ CRI LEDs and is available with a Lambertian or asymmetric lens optic.

SPECIFICATIONS

Fixture housing constructed of an extruded aluminum tube, frosted acrylic extruded lens and sheet aluminum end caps

Fixture arms are constructed of steel pipe, Ø5/8" extruded aluminum sleeves and machined aluminum end cap couplers.

Mounting plate options include a Ø4-3/4" aluminum plate for mounting to 4" octagonal wall boxes or Ø1-3/8" aluminum plate for mounting to accessible panels.

Standard finishes as shown below

Single and continuous run fixtures available with arm center distances of 24"-90"

Arms allow fixture to project from a wall or ceiling nominally 3", 6", 12" or 18"

Fixture housing rotates 332° and is locked in place with hex fastener

Included standard remote 120-277V driver offered with 0-10V dimming or non-dim (other dimming driver options available)

Extruded acrylic lens options available for Lambertian or asymmetric light distributions

Fixture wired with 10', low voltage leads (measured from the end cap)

Standard outputs range from 400 to 535 lumens per foot, dependent on optic

LEDs available in 2700K, 3000K, 3500K, and 4000K, within a 3 step MacAdam ellipse, all with 90+ CRI typical

Life: 50,000 hours L₇₀

Limited five year warranty

UL and C-UL listed for dry and damp locations

PROFILE

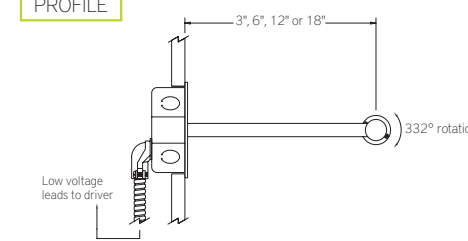

SECTION

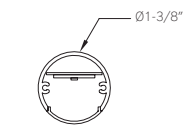

PERFORMANCE

Note: All data reflects fixtures with 3500K LEDs

NOMINAL LENGTH	OPTIC OPTION	OUTPUT	LUMENS/FT	WATTS/FT	LUMINAIRE LUMENS	EFFICACY (LPW)
4'	Lambertian	L: low	400	3.9	1675	102
		R: regular	520	5.6	2175	92
	Asymmetric	L: low	415	3.9	1735	106
		R: regular	535	5.6	2253	96



Light temperature to be between 2700K-3000K



Concrete Paver (if street is brick)
 Manufacturer: Oberfields
 Product: Jamestown
 Color: Charcoal



Concrete Paver Border (if street is brick)
 Manufacturer: Unilock
 Product: Beacon Hill Smooth
 Color: Dark Charcoal

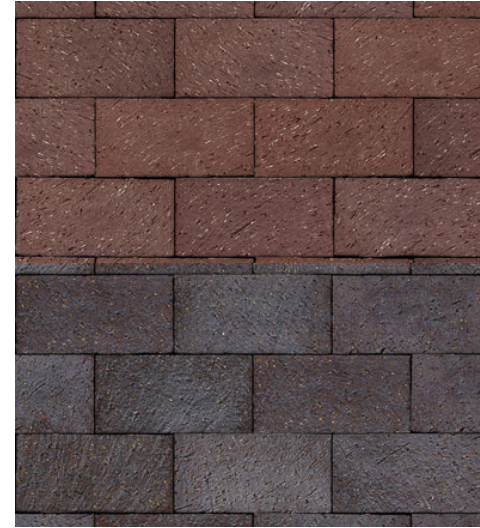

Clay paver blend (if street is asphalt)
 Manufacturer: Endicott
 Product: Medium Ironspot #46 (top)
 Dark Ironspot (bottom)



Limestone steps
 (see landscape plans for more information)



Wood bench on stone wall
 (see landscape plans for more information)



limestone wall with cast stone cap
 (see landscape plans for more information)



Expandable Tree grate
 Manufacturer: Iron Age Designs
 Product: 5'x5' Tree Grate - Heel Proof



Bike Rack
 Manufacturer: Madrax
 Product: Opal Bike Rack
 Color: P.C. Bronze



1. Custom Bistro Table
24" Dia x 29" H - Black powder coated
steel table top and decorative base



2. West Elm Riverview Outdoor
Stacking Dining Chair - 19.3" W x
20" D x 31.2" H - Dark Bronze



3. Custom Counter Stool - 15" Dia
x 24" H - White fiberglass seat with
black powder coated steel base



4. Custom Kiosk Cart - 48" W x
30" D x 96" H - Wood clad base on
casters with fade resistant umbrella
topper

62 RED CABIN & STAIRCASE



62 N. Riverview St

A majority of the historic red cabin at 62 N. Riverview St will be preserved to its entirety. Programatically, it will become an original cocktail bar and restaurant open to the public year round.

The main portion of the red house will be restored. The existing horizontal and board & batten siding will be repaired and a new asphalt shingle roof will be installed. The existing arched window on the West elevation is not original to the cabin, and will be replaced with historically accurate casement windows. A small gable will be added to the roof on the West facade to denote the main building entrance. On the north, an additional door is to be added at the B1 level for access to the North addition.

The existing rear addition to the East has settled significantly and will be rebuilt on its existing foundation. The design of this addition references the original open porch through the use of vertical trim boards and large casement windows, bringing in natural light from the east.

To the North, a deck and enclosed addition will be built at the B1 level providing seating for the restaurant. A bifold window on the East facade of the addition can open to provide views across the river. To the East of the main building, a lower deck with an open pergola will be built aligning with the B2 level to provide outdoor seating for the restaurant. A bar inside the B2 level will open with bifold windows to the lower deck.









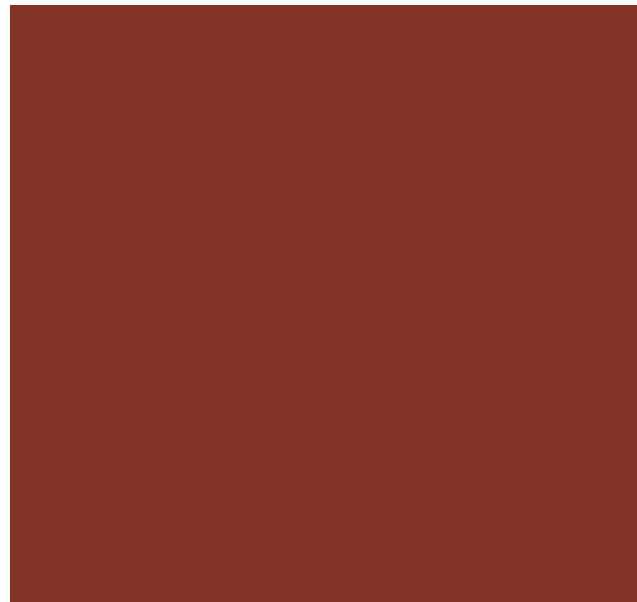

1. SW 6335 Fired Brick

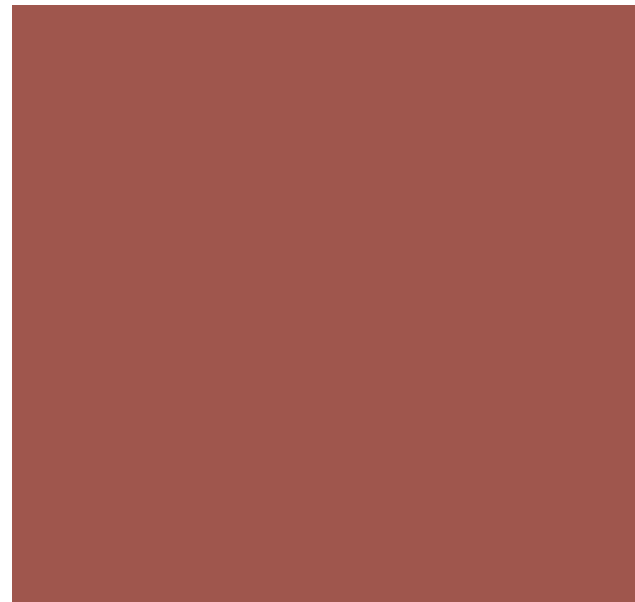

2. SW 6327 Bold Brick

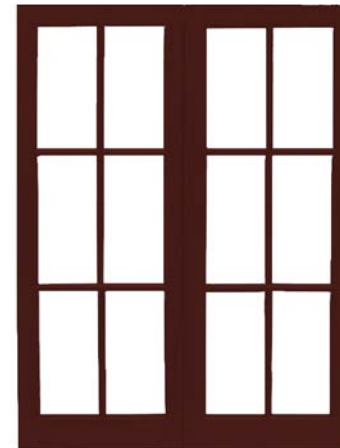

3. Pella Lifestyle Series aluminum clad casement window with 6-light traditional grille pattern and spacers between glass panes - color Red Brick (or Andersen or equivalent)

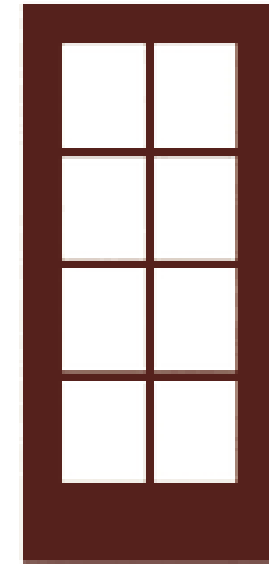

4. Pella fiberglass entry door with traditional simulated-divided-light grille and spacers between glass panes - color Red Brick (or Andersen or equivalent)



5. GAF Timberline UHDZ Dimensional Asphalt Shingles - color Pewter Gray



6. Standing Seam Metal Roof, DMI Aged Copper



7. James Hardie, Hardie Panel Smooth fiber cement siding medium grey to match existing COHatch

62 N Riverview Entry Door



Flush Glazed Full Light Fiberglass Entry Door

For entryways that desire more natural light, Flush Glazed Full Light fiberglass front doors are a great option from the #1 preferred brand for entry doors.²⁴ This contemporary front door displays clean lines with a full glass window. These energy-efficient fiberglass front doors provide years of dependability for your home.

- Dent resistant material that won't rust or corrode.
- Stunning glass options, including obscure designs for added privacy.
- Innovative, low-maintenance frame system is rot resistant and energy efficient.
- Product #500004

in color Red Brick with 6-light grille

62 N Riverview Casement Window



PELLA® IMPERVIA®
Fiberglass Casement Window

3.96 ★★★★★ 437 Reviews

Pella Impervia fiberglass casement windows are hinged on the side and are made from our proprietary fiberglass, the strongest material for windows.³² Sleek profiles and clean lines deliver a timeless style. The revolutionary Easy-Slide Operator hardware solution allows you to simply slide to open your window without the effort of cranking.

- A variety of color options, including Black.
- Patented lock system engages multiple locks, with one easy-to-use lock-lever for lasting security.
- Low-maintenance and will never need to be repainted or refinished.
- Product #400003

in color Red Brick with 6-light grille

62 N Riverview Wall Sconce

Located on West facade next to entry door



Anchorage 120V Outdoor Wall Sconce
SPEC # HIN1050826



BRAND Hinkley Lighting

DESCRIPTION
The Anchorage 120V LED Outdoor Wall Sconce features a solid Aluminum lantern design with Clear Glass planes.



Shown in: Aged Zinc / Clear

Light temperature to be between 2700K-3000K

SHADE COLOR	Clear
BODY FINISH	Aged Zinc
WATTAGE	5W
DIMMER	Low Voltage Electronic
DIMENSIONS	7"W x 13"H x 6"D
BULB INCLUDED	
LAMP	1 x A19/Medium (E26)/5W/120V LED

Technical Information

LUMINOUS FLUX	450 lumens
LUMENS/WATT	90.00
LAMP COLOR	2700K
COLOR RENDERING	90 CRI

SPEC # HIN1050826

62 N Riverview Gooseneck Sconce

Located on West facade on chimney above signage



GOOSENECK



Fixture: 7" Shade

Finish: 91 (Black - Shade White In...)

Gooseneck Arm Option: HL-A (HL-A, 22" Gooseneck...)

Gooseneck Arm Color: 91 (Black - Wet Rated)

Gooseneck Arm Accessory: None

Wire Guard Option: None

Glass & Guard Option: None

Lamp Selection: Medium Base E26 Socket...

Dusk to Dawn Sensor Option: None

Part Number: H-18107-91/HL-A-91-INC
Request Part Number

Information Gallery Documents

Additional Information

Finish: Our powder coat finishes undergo a thorough 5-step process that promotes the longevity and durability of our shades. A diverse assortment of finishes is available.
Mounting: A choice of gooseneck arm varieties is available.
Back Plate Diameter: Varies.
Max Wattage Per Socket:

- 200 Watt Incandescent with Standard Medium Base Socket.
- 100 Watt Incandescent with Standard Medium Base Socket with CGU, WGU, or SGU.

Number of Sockets: 1
Application: UL/ETL listed for wet locations (except when using "Dry Rated" finishes).
Manufactured in the U.S.A.
No Returns Accepted on This Product.

LED, HID, and Metal Halide options also available. Please call for more info.

SPECIFICATIONS:

Product Number	size	height	width	projection
H-18107 (7" SHADE) (7" Shade)	7"	8"	7"	
H-18108 (8" SHADE) (8" Shade)	8"	8"	8"	
H-18110 (10" SHADE) (10" Shade)	10"	10.5"	10"	
H-18112 (12" SHADE) (12" Shade)	12"	12"	12"	
H-18114 (14" SHADE) (14" Shade)	14"	14.5"	14"	

NOTES:

UL Listed
ETL Listed

Light temperature to be between 2700K-3000K

62 N Riverview Wall Sconce

Located on West facade on gable above entry door



Danbury 6" High Black Dusk to Dawn LED Outdoor Wall Light

34 Reviews

\$79.99

Pay in 4 interest-free payments of \$20.00 with [PayPal](#). [Learn more](#)

Free Shipping & Free Returns*
Ships Today if ordered in the next 58 Min.

1 ADD TO CART SAVE



Add security to your home with this energy-efficient LED outdoor wall light that features a photocell sensor.

Product Details

LED LED Dusk to Dawn

- 7" wide x 6" high. Extends 8 3/4" from the wall. Backplate is 6" wide x 4 1/2" wide. Weighs 1.36 lbs.
- Built-in 10 watt non-dimmable LED, comparable to a 60 watt incandescent. 790 lumens. 3000K color temperature. 80 CRI.

Inspired by modern industrial and barn light designs, this outdoor wall light comes in a durable steel frame, painted black for a classic look. The built-in LED light source within offers long-saving, energy-saving technology for a modern world. A dusk-to-dawn photocell feature allows the light to be turned on/off automatically at sunrise and sunset.

Light temperature to be between 2700K-3000K



53 N RIVERVIEW ST



53 N. Riverview St

The historic home at 53 N. Riverview Street will be restored and turned into a private coworking and meeting space for COhatch members. On the weekends it will open for events and markets of all sorts.

On its exterior, the house's staggered shake siding has deteriorated beyond repair; it is proposed to be replaced by new, straight cedar shakes. The porch foundation is structurally unsound and will be rebuilt in place with stacked stone piers and framed open lattice. The gabled roof above the open porch will be rebuilt in place and opened up to express the 3-part craftsman-style wood frame details. The existing roof of the addition in the west contains hazardous materials and will be demolished. The new roof of this area will be raised 8" to that of the rest of the home. At the doorway of the ADA entrance to the west, a small awning is proposed to be added.

The ceilings in the original portion of the home will be removed to create a double height space and reveal the historic rafters. The basement stairs will be demolished and replaced with a hatch to provide a service access. A new mantle and fireplace will be installed at the existing chimney.



1. SW 2826 Colonial Revival Green Stone



2. SW 2846 Roycroft Bronze Green



3. Pella Lifestyle Series aluminum clad double-hung window with 3-over-1 traditional simulated-divided-light grille and spacers between glass panes - color Red Brick (or Andersen or equivalent)



4. Pella fiberglass entry door with 12-light traditional simulated-divided-light grille and spacers between glass panes - color Early American (or equivalent)



5. GAF Timberline UHDZ Dimensional Asphalt Shingles in color Pewter Gray

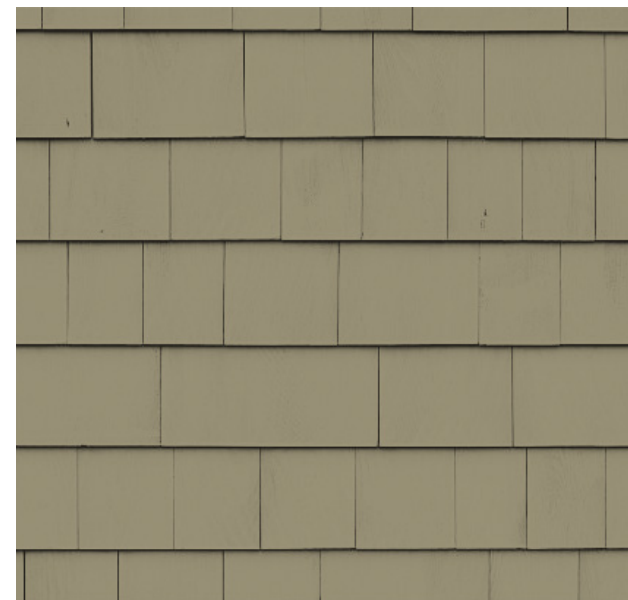

6. James Hardie, Hardie Shingle Straight Edge Panel Siding



7. Classic Rock Face Block #201 - cast concrete veneer to be used to match original historic stacked stone where not present

53 N Riverview Composite Shake Siding

Hardie® Shingle Siding

Add timeless style to your home with durable Hardie® Shingle siding that mimics the distinct look of classic cedar shake.

Showing products for: [43221](#)

Hardie® Shingle

Find your style

Your home is a blank canvas. Experiment with Hardie® Shingle styles, textures, and stunning colors featuring our ColorPlus® Technology finishes to create your masterpiece.



Specs: Straight Edge Panel

Width	15.25 in	15.25 in	15.25 in	15.25 in
Length	48 in	48 in	48 in	48 in
Thickness	0.25 in	0.25 in	0.25 in	0.25 in
ExposureWidth	2.326 in	2.326 in	2.326 in	2.326 in
Dream Collection®			•	
Primed for Paint				•
Statement Collection®	•			

53 N Riverview Rockface Veneer

CLASSIC ROCK FACE BLOCK
#201 - Facing Block Solid

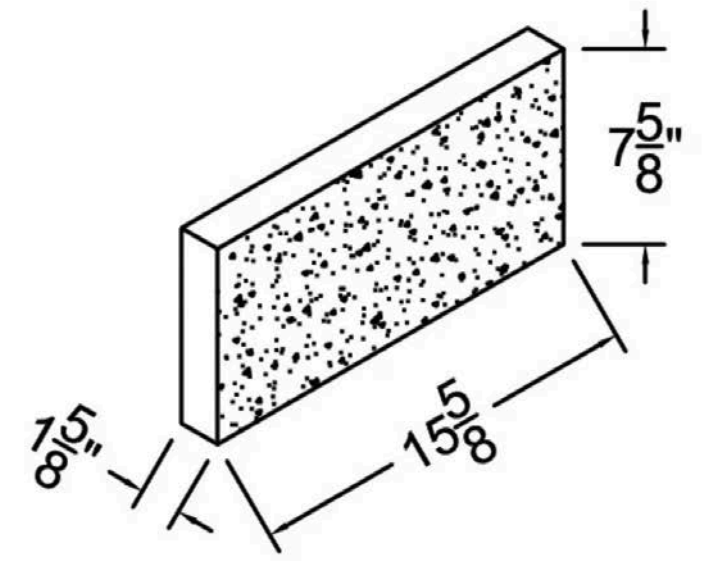

1 Sided
 Designs 1,2,3,4,5,6,7,8,9,10,11,12

Block	2"x8"x16" Solid
Description	Facing Block
Designs	1 2 3 4 5 6 7 8 9 10 11 12

53 N Riverview Entry Door



Flush Glazed 3/4 Light Fiberglass Entry Door

Make a contemporary design statement with a Flush Glazed 3/4 Light fiberglass front door. Glass is inset into the frame for cleaner sightlines and more light than the traditional 3/4 Light door. With a high performing composite frame and fiberglass panel, you can trust your front door to resist against dents, rot and corrosion.

- Optional obscure, textured glass creates more privacy in your entryway.
- High performing and exceptionally durable fiberglass panel.
- Available in realistic wood grain or with a smooth texture, and in a variety of beautiful finishes.
- Product #500005

Permanently bonded to the interior and exterior of the glass, simulated-divided-light grilles deliver the authentic look of individual panes of glass with better energy efficiency.

Full Light 3/4 Light 1/2 Light

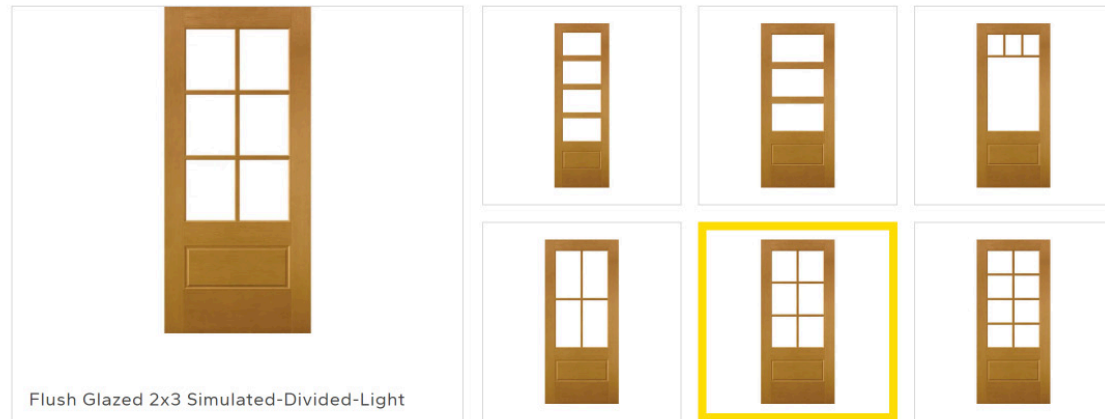

in color Early American with 12-light grille

53 N Riverview Window

PELLA® IMPERVIA®
Fiberglass Double-Hung Window

3.96 ★★★★★☆ [437 Reviews](#)

Pella Impervia fiberglass double-hung windows provide outstanding resistance to water, wind and outside noises — while delivering energy efficiency, security and ease of operation. But you don't have to sacrifice performance for style. Clean sightlines provide a consistent aesthetic. And our powder-coat finish gives a durable finish which resists chalking, fading and scratching.

- Commercial grade strength and performance.¹⁵
- Exclusive cam-action lock design improves the security of the window and creates a stronger seal.
- Sashes tilt in, allowing you to easily clean the exterior of your windows from inside your home.
- Product #400001



in color red brick with 3-over-1 grille

53 N Riverview Wall Sconce



Coldwater 4053 Outdoor Wall Light
SPEC # MAX496287

BRAND Maxim Lighting

DESCRIPTION
Coldwater 4053 Outdoor Wall Light is a traditional craftsman/mission style piece. It features Honey glass with a Burnished finish. One 100 watt, 120 volt A19 medium base bulb is required, but not included. Wet location rated. 6 inch width x 12 inch height x 8.5 inch depth.



Shown in: Burnished / Honey

Light temperature to be between 2700K-3000K

SHADE COLOR	Honey
BODY FINISH	Burnished
WATTAGE	72W
DIMMER	Standard 120V
DIMENSIONS	6"W x 12"H x 8.5"D
BULB NOT INCLUDED	
LAMP	1 x A19/Medium (E26)/72W/120V Incandescent

SPEC # MAX496287

53 N Riverview Shed Gooseneck Sconce



CLASSIC WAREHOUSE SHADE WALL LIGHT

Fixture: 12" Shade

Finish: 91 (Black - Shade White In...)

Wire Guard Option: None

Glass & Guard Option: None

Lamp Selection: Medium Base E26 Socket...

Dusk to Dawn Sensor Option: None

Part Number: H-15312-B-91-INC

Request Part Number

Information Gallery Documents

Additional Information

Finish: Our powder coat finishes undergo a thorough 5-step process that promotes the longevity and durability of our shades. A diverse assortment of finishes is available.

Mounting: Wall Light, fixture to point in the down position only.

Back Plate Diameter: Varies.

Max Wattage Per Socket:

- 200 Watt Incandescent with Standard Medium Base Socket.
- 100 Watt Incandescent with Standard Medium Base Socket with CGU, WGU, or SGU.

Number of Sockets: 1

Application: UL/ETL listed for wet locations (except when using "Dry Rated" finishes).

Manufactured in the U.S.A.

No Returns Accepted on This Product.

LED, HID, and Metal Halide options also available. Please call for more info.

SPECIFICATIONS:

PRODUCT NUMBER	SIZE	HEIGHT	WIDTH	PROJECTION	CANOPY DIAMETER
H-15312-B (12" SHADE)	12"	12.5"	12"	15"	6.25"
H-15314-B (14" SHADE)	14"	15"	14"	16"	6.25"
H-15316-B (16" SHADE)	16"	15"	16"	18"	6.25"

NOTES:

- UL Listed
- ETL Listed
- Wet Rating **Some finishes and accessories may change fixture rating
- Energy Efficient
- Made in the USA
- Made to Order
- No Return

SPECIFICATIONS:

Product Number	size	height	width	projection
H-15312-B (12" SHADE) (12" Shade)	12"	12.5"	12"	15"
H-15314-B (14" SHADE) (14" Shade)	14"	15"	14"	16"
H-15316-B (16" SHADE) (16" Shade)	16"	15"	16"	18"

NOTES:

- UL Listed

Light temperature to be between 2700K-3000K

53 N Riverview Patio Fence Light



Landscape Lighting / Deck - Step Lighting / Solar / Traditional / Style # 6H874

Fairmont 5"x5" Black Outdoor LED Solar Post Cap

1 Review

\$34.99

Pay in 4 interest-free payments of \$8.75 with [PayPal](#). [Learn more](#)

Ships Free with Orders Over \$49* | [Price Matching Policy](#)
In Stock - [Ships in 3 to 5 Days](#)



1 ADD TO CART SAVE

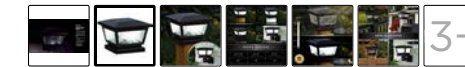

CHAT

Brilliant white light illuminates an exterior space with this black outdoor LED solar post cap.

Product Details

- 7" wide x 5" high.
- Includes two high-output LEDs: 10 lumens, comparable to a 5 watt incandescent. 4500K - 5500K color temperature.
- Fairmont 5x5 energy-efficient LED solar post cap light.
- Black finish ABS construction. Real pebbled glass.
- Adaptors included to fit over an actual 5"x5", 4"x4" or 3 1/2"x3 1/2" post.

Classic charm and energy efficiency create an optimal choice in this LED solar post cap, a great choice for casual custom walkways and landscaped areas. All-weather and versatile, its black finish framed shade embellishes real pebbled glass, producing a brilliant white light to illuminate a targeted space. Fits three post sizes, and includes a wall adaptor for remote operation.

Light temperature to be between 2700K-3000K





Concrete Paver (patio)
Manufacturer: Unilock
Product: Boulevard
Color: Granite Fusion



Concrete Paver Border (patio)
Manufacturer: Unilock
Product: Beacon Hill Smooth
Color: Dark Charcoal



Reconstructed historic stone wall
(see landscape plans for more information)



Clay Paver (approach walks)
Manufacturer: Belden Brick
Product: Saxony Blend

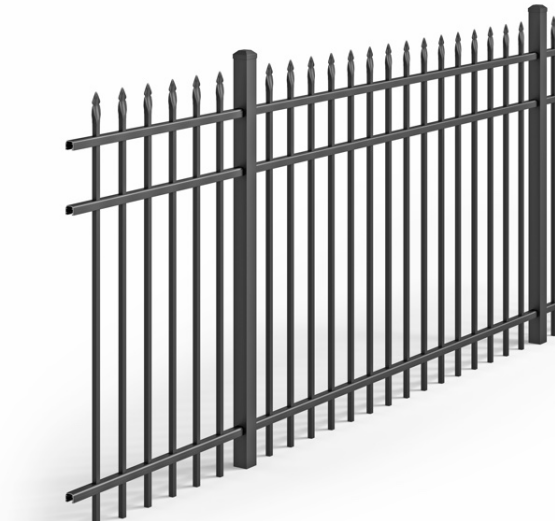

Metal fence
Manufacturer: Ultra
Product: UAS 100 Spear Top
Color: Gloss Black



Limestone steps
(see landscape plans for more information)

Front Porch



1. Fermob Opera+ Chair - 15" W x 14" D x 35" H - Honey color



2. Fermob Opera+ 26" Round Table - 26.5" Dia x 29" H - Honey color

Back Patio



1. Bayocean Rectangular Table - Rejuvenation - 72" W x 36" D x 30" H



2. Bayocean Side Chair - Rejuvenation - 20" W x 23" D x 32" H



3. West Elm Slope Outdoor Lounge Chair - 26.2" W x 28.5" D x 27.75" H



4. Terra Cavallo 43" Round Coffee Table - 43.5" Dia x 15.75" H



5. Pottery Barn 9' Round Outdoor Patio Umbrella - 9' Dia x 8'-6" H

45 N RIVERVIEW ST



45 N. Riverview St

The historic home at 45 N. Riverview Street will be restored and turned into a private coworking and meeting space for COhatch members. On the weekends, it will open for events and markets of all sorts.

Externally, the house's existing horizontal siding, corner trim, and standing seam metal roof are proposed to be repaired and restored. The roof height of the enclosed porch will be raised by 1'-3" to 8'-0" in order to match that of the main portion of the house. Similarly, the bottom of the addition to the west is to be raised 1'-3", decreasing the slope of the roof to align with the 8'-0" bearing height of the rest of the house. The enclosed porch to the east will receive a fiber cement board siding and trim, and its CMU foundation will receive a stacked stone veneer. A new porch with open lattice and stacked stone piers, is proposed to replace its existing foundation, which has deteriorated over the years.

In the interior space, the second floor attic is to be removed to create a double height space in the original portion of the building. The existing chimney is not structurally sound and will be demolished and rebuilt in place. The current ladder access to the basement will be removed and a hatch installed to provide a service access. The existing floor of the addition in the east is proposed to increase by 8" to provide ADA accessibility throughout the entire building.



1. SW 2848 Roycroft Bronze Green



2. SW 7642 Pavestone



3. SW 9565 Forged Steel



4. Standing seam metal roof,
DMI Putty

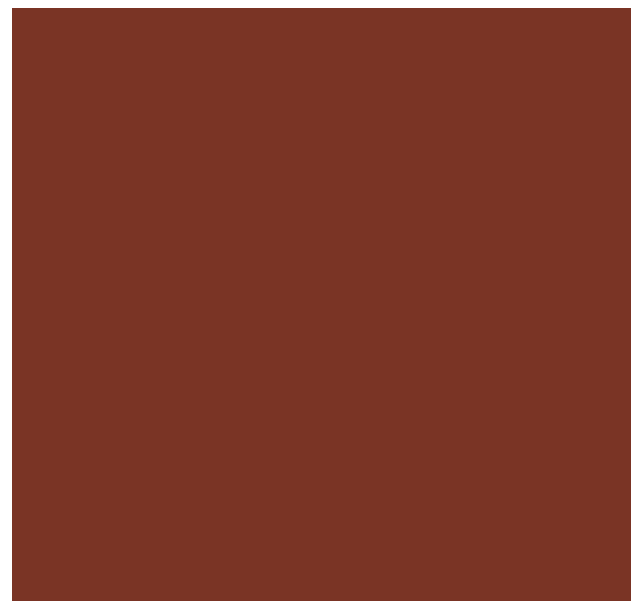

5. SW 2839 Roycroft Copper Red

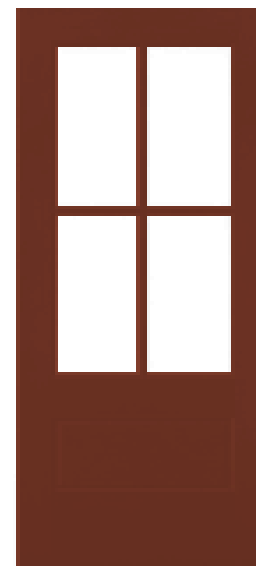

6. Pella fiberglass entry door with
4-light traditional simulated-divided-
light grille and spacers between
glass panes - color Red Brick (or
equivalent)



7. Pella Lifestyle Series aluminum clad
double-hung window with 2-over-2
traditional simulated-divided-light
grille and spacers between glass
panes - color Portabello (or Andersen
or equivalent)

45 N Riverview Entry Door



Flush Glazed 3/4 Light Fiberglass Entry Door

Make a contemporary design statement with a Flush Glazed 3/4 Light fiberglass front door. Glass is inset into the frame for cleaner sightlines and more light than the traditional 3/4 Light door. With a high performing composite frame and fiberglass panel, you can trust your front door to resist against dents, rot and corrosion.

- Optional obscure, textured glass creates more privacy in your entryway.
- High performing and exceptionally durable fiberglass panel.
- Available in realistic wood grain or with a smooth texture, and in a variety of beautiful finishes.
- Product #500005

Permanently bonded to the interior and exterior of the glass, simulated-divided-light grilles deliver the authentic look of individual panes of glass with better energy efficiency.

Full Light 3/4 Light 1/2 Light

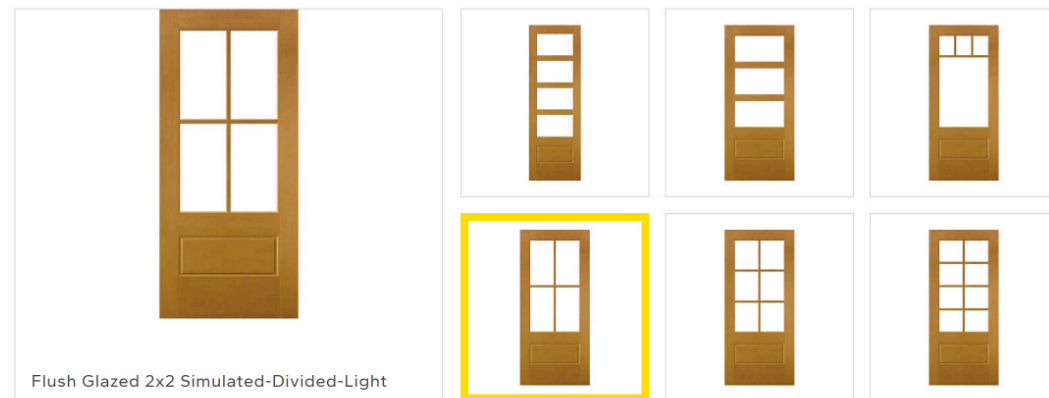

Flush Glazed 2x2 Simulated-Divided-Light

in color Red Brick with 4-light grille

45 N Riverview Window

PELLA® IMPERVIA® Fiberglass Double-Hung Window

3.96 ★★★★★ [437 Reviews](#)

Pella Impervia fiberglass double-hung windows provide outstanding resistance to water, wind and outside noises – while delivering energy efficiency, security and ease of operation. But you don't have to sacrifice performance for style. Clean sightlines provide a consistent aesthetic. And our powder-coat finish gives a durable finish which resists chalking, fading and scratching.

- Commercial grade strength and performance.¹⁵
- Exclusive cam-action lock design improves the security of the window and creates a stronger seal.
- Sashes tilt in, allowing you to easily clean the exterior of your windows from inside your home.
- Product #400001



in color Portabello with 1-over-1 grille

45 N Riverview Wall Sconce

Lightology

Manor House Small Outdoor Wall Light

SPEC #

HIN51863



BRAND Hinkley Lighting

DESCRIPTION

The Manor House Small Outdoor Wall Sconce features Clear beveled glass panels with Black finish over cast aluminum. One 60 watt, 120 volt, A19type Medium base incandescent lamp is required, but not included. General light distribution. 7 inch width x 12 inch height x 7 inch depth. Rated for Wet Locations.

Light temperature to be between 2700K-3000K



Shown in: Black / Clear



SHADE COLOR	Clear
BODY FINISH	Black
WATTAGE	8W
DIMMER	Standard 120V
DIMENSIONS	7"W x 12"H x 7"D
BULB NOT INCLUDED	
LAMP	A19/Medium (E26)/8W/120V LED A19/Medium (E26)/120V LED A19/Medium (E26)/60W/120V Incandescent

SPEC # HIN51863

45 N Riverview Patio String Lights

LINEAR LIGHTING / LS-M



LIGHT STRING

Commercial Grade E26

Commercial E26 Medium base stringers are perfect for any outdoor patio or lighting display. Commercial grade stringers are weather resistant and designed for long term usage. Includes guy-wire loop for additional support for large spans or spaces. E26 base sockets are perfect for any standard LED or incandescent bulbs giving you the creative freedom for your lighting display.

- Great decorative lighting product for patios, gazebos, building outlines, event tents, and retail walkways
- Factory-molded, formulated PVC sockets on heavy-duty wire form a tight weather resistant seal around bulbs
- Suitable for indoor and outdoor commercial applications
- E26 Medium base decorative bulbs sold separately

Light temperature to be between 2700K-3000K



LS-M SERIES QUICK SPECS

SERIES	LS-M
INPUT VOLTAGE	120V AC
WATTAGE	25W per socket
MAX RUN	1200W
CABLE TYPE	14AWG SJTW 2-Wire
SOCKET TYPE	E26
SOCKET SPACING	24"
CUT INCREMENTS	Field cuttable (Must be properly sealed)
IP RATING	IP64 - Wet Location

Interconnected strings must be properly sealed and strain relief protected with electrical tape at each connection point. For non-rated LS product, any cut ends must be sealed with LS-MMS-END and/or electrical tape (ensure proper seal to preclude entrance of water). Keep lamps at least 4.9m/16ft away from pools and spas.

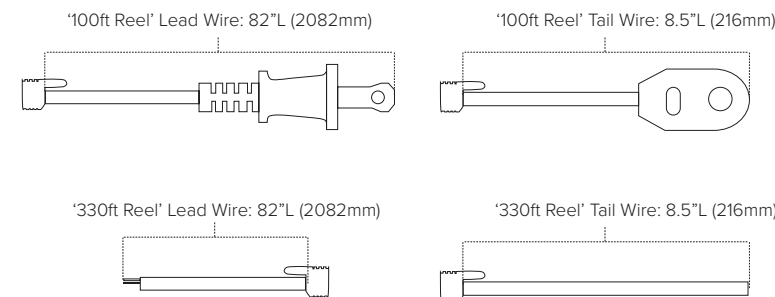

PROJECT: _____

TYPE: _____

LOCATION: _____

CATALOG NUMBER: _____



LS-M SERIES QUICK DIMENSIONS

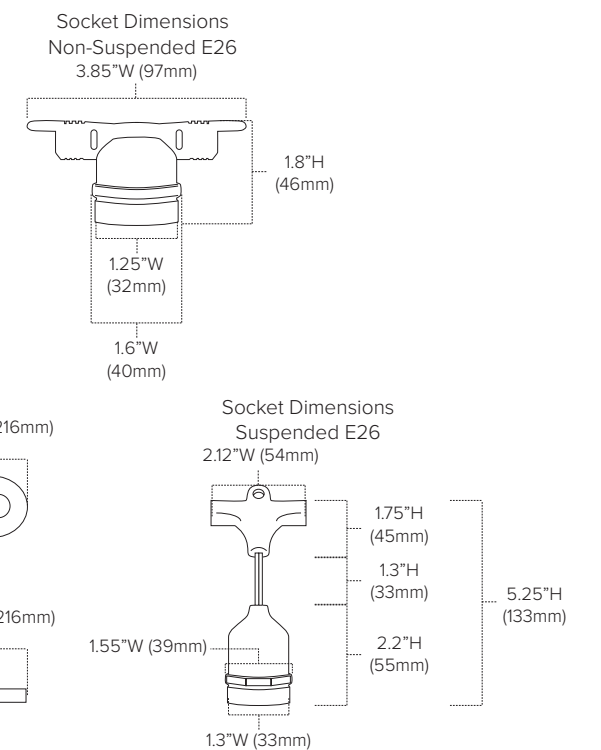

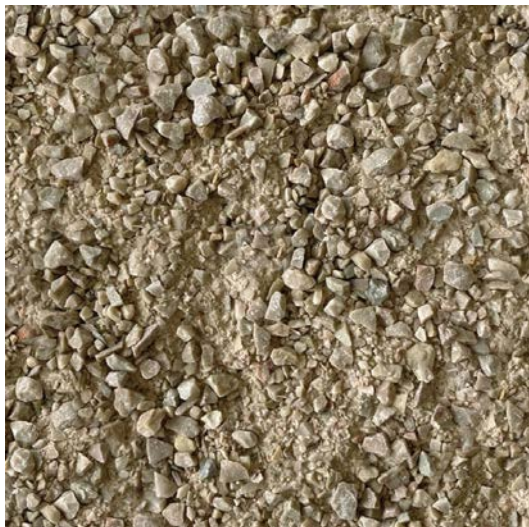

Crushed stone pavement
(patio and ADA access)
Manufacturer: Kafka Granite
Product: Beige Blend Marble



Clay Paver (approach walks)
Manufacturer: Belden Brick
Product: Saxony Blend

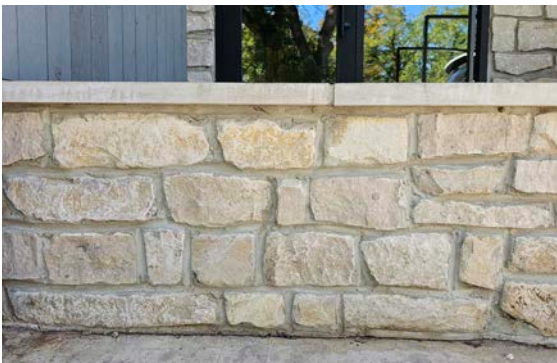

Stone wall with cast stone cap
(see landscape plans for more information)



Limestone steps
(see landscape plans for more information)

Front Porch



1. Bayocean Lounge Chair - Rejuvenation - 30.25" W x 30.5" D x 28" H

Back Patio



1. EMU Sid Rectangular Picnic Table - 96" W x 62" D x 30" H



2. Crate & Barrel Polywood Paso Outdoor Patio Adirondack Chair - 32" W x 34" D x 28" H - Lime



3. Solo Stove Canyon 2.0 - 20" Dia x 19" H



2. 17 Stories Olley Round Outdoor Side Table - 15.5" Dia x 18" H



4. Kathy Kuo Home Skylar Modern Classic Grey Concrete Round Outdoor Cylinder Stool - 13.75" Dia x 18" H

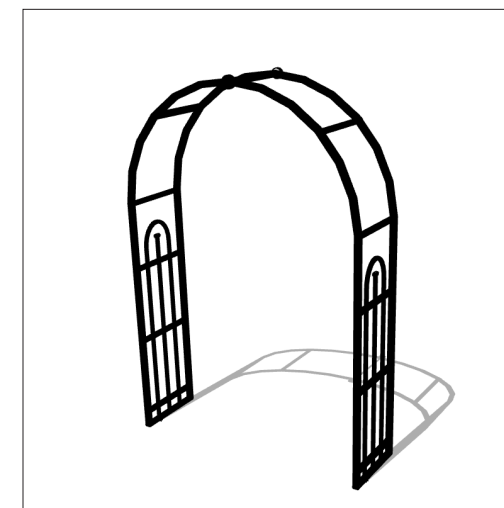

5. Custom Arbor - 54" W x 18" D x 78" H - Black powder coated steel frame

37 N RIVERVIEW ST



37 N. Riverview

Built around the 1870s, this historic home at 37 N. Riverview Street will be carefully renovated and turned into a private coworking and meeting space for COhatch members. On the weekends, it will open for events and markets of all sorts.

The exterior of the house will be repaired and restored. Different widths of horizontal cedar siding will be utilized to differentiate the original structure from later additions, and the board & batten siding on the west facade will be replaced. The current porches are proposed to be demolished and replaced by a wrap-around porch to enhance the house's curb appeal and help activate street life. The roof height of the existing addition to the west is proposed to increase by 1'-8," resulting in a new bearing height of 8'-0" to match the rest of the building. All roofs, new and existing, will be standing seam metal roofs.

In the interior space, the current basement stairs will be demolished and replaced with a hatch to provide a service access. The second floor attic will be removed to create a double height space, revealing the historic rafters. The existing mantle and stairs will be kept in place to acknowledge the original program of the building.



1. SW 2821 Downing Stone

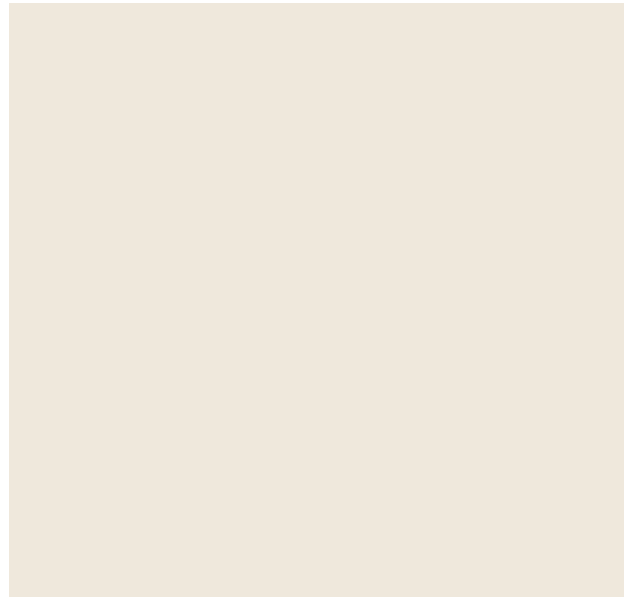

2. SW 7002 Downy



3. Standing Seam Metal Roof DMI Dark Bronze



4. Pella Lifestyle Series aluminum clad double-hung window with 6-over-1 traditional simulated-divided-light grille with spacers between glass panes - color Iron Ore (or Andersen or equivalent)



5. Pella Fan Light Rectangle Fiberglass Entry Door with 6-light grille and spacers between glass - color Classic White (or equivalent)

37 N Riverview Entry Door



Fan Light Rectangle Fiberglass Entry Door

For homes that prefer more privacy, look no further than a Fan Light Rectangle fiberglass front door. Featuring a minimal amount of glass, the quarter-light rectangle offers a contemporary twist to the traditional panel style — ideal for both traditional and transitional homes.

- Obscure, decorative and clear glass options to balance the amount of light and privacy.
- Smooth and wood-grained texture options to meet your home's desired aesthetic.
- Incredibly strong and durable panel for lasting performance and low-maintenance beauty.

Talk to a Pella Rep for Pricing

CONTACT A PELLA REP

in color Classic White with 6-light grille

37 N Riverview Window



PELLA® IMPERVIA®

Fiberglass Double-Hung Window

3.96 ★★★★★ [437 Reviews](#)

Pella Impervia fiberglass double-hung windows provide outstanding resistance to water, wind and outside noises — while delivering energy efficiency, security and ease of operation. But you don't have to sacrifice performance for style. Clean sightlines provide a consistent aesthetic. And our powder-coat finish gives a durable finish which resists chalking, fading and scratching.

- Commercial grade strength and performance.¹⁵
- Exclusive cam-action lock design improves the security of the window and creates a stronger seal.
- Sashes tilt in, allowing you to easily clean the exterior of your windows from inside your home.
- Product #400001

in color Iron Ore with 6-over-1 grille

37 N Riverview Wall Sconce

Lightology

Briton Outdoor Wall Sconce

SPEC #

STC351863



BRAND

Satco

DESCRIPTION

Briton Outdoor Wall Sconce features Clear glass panels with an Old Bronze, Textured Black, or White finish. One 60 watt, 120 volt A19 type Medium base incandescent bulb is required, but not included. UL listed for wet locations. 6 inch width x 18 inch height x 6.125 inch depth.



Shown in: Textured Black / Clear

Light temperature to be between 2700K-3000K

SHADE COLOR	Clear
BODY FINISH	Textured Black
WATTAGE	8W
DIMMER	Standard 120V
DIMENSIONS	6"W x 18"H x 6.13"D
BULB NOT INCLUDED	
LAMP	1 x A19/Medium (E26)/8W/120V LED 1 x A19/Medium (E26)/60W/120V Incandescent

SPEC # STC351863

37 N Riverview Patio Pendant

Lightology

Markis Outdoor Pendant

SPEC #

EUF1263204



BRAND

Eurofase

DESCRIPTION

The Markis Outdoor Pendant offers a relaxed, natural look for your porch, outdoor dining area, or other covered outdoor space. Its round woven rope shade lends an airy feel and lets warm ambient light shine through.



Shown in: Black / Khaki

Light temperature to be between 2700K-3000K

SHADE COLOR	Khaki
BODY FINISH	Black
WATTAGE	9W
DIMMER	Standard 120V
DIMENSIONS	22"W x 17"H
BULB NOT INCLUDED	
LAMP	1 x A19/Medium (E26)/9W/120V LED

SPEC # EUF1263204





Irregular flagstone pavers
(see landscape plan for more information)



Wood pergola
(see landscape plans for more information)



Clay Paver (approach walks)
Manufacturer: Belden Brick
Product: Saxony Blend



Wood deck
(see landscape plans for more information)



Stone Outcropping wall
(see landscape plans for more information)

Front Porch



1. Polywood Vineyard Porch Rocking Chair - 27.25" W x 34.25" D x 45.88" H - Slate Gray



2. Polywood Grant Park 48" Swing - 48.5" W x 23.19" D x 23.97" H - White

Back Patio



1. Williams Sonoma Larnaca Outdoor Sofa - 96" W x 28.5" D x 31.75" H - Slate Gray



2. Blu Cot Hot Mesh Lounge Chair - 28" W x 27" D x 26" H - Natural Yellow



3. Terra Belvedere Coffee Table - 59.75" W x 30" D x 13.75" H - Charcoal



4. Terra Sonoma Dining Chair - 23.5" W x 23.5" D x 30" H



5. Terra Belvedere 36" Umbrella Table - 35.5" W x 35.5" D x 30" H - Charcoal



6. Pottery Barn Cantilever Outdoor Patio Umbrella - 10' W x 6.5' D x 8'-6" H - Black