

Giving Garden Eagle Project

6659 Emerald Pkwy, Dublin, Oh 43017

Project Owner: Soham Sor
Phone Number: 614 - 973 - 2540
Gmail: soham.sor@gmail.com
Address: 6815 Myrtlestone st, Dublin, Oh
43016

Project Representative: Sarah Esala
Phone Number: 614 - 410 - 4404
Gmail: sesala@dublin.oh.us
Address:

III. Project Narrative

The purpose of my project is to design and construct 2 elevated and 6 raised garden beds at the Giving Garden at Coffman Homestead in Coffman Park. It provides a sustainable, accessible, and easy-to-maintain gardening space. This project is aimed to support local gardening efforts, improve soil quality, and promote community involvement in gardening. The Giving Garden currently has 8 beds which have become dated and needs to be replaced with new beds. Elevated beds will also help with gardening activities involving senior and disabled members. The project uses design elements which are inline with the Dublin Historic Coffman Homestead Park.

Relationship to the Historic Context and Character

The proposed design respects the historical integrity of the Dublin Historic Coffman Homestead by integrating materials and styles that reflect the surrounding heritage. Cedar wood will be used to prevent rot and the style will not be too complicated. The elevated and raised garden beds will blend with the site's aesthetic, preserving the historic charm while introducing functional improvements.

Alignment with Applicable Guidelines

The project aligns with the Dublin Community Plan, Historic District Code, and Historic Design Guidelines by promoting sustainability, accessibility, and community engagement—values emphasized within these documents. The elevated garden beds enhance accessibility for senior and disabled members, fulfilling inclusive design principles while maintaining visual harmony with the Historic District.

- **Vicinity and Context and Existing Conditions plan**

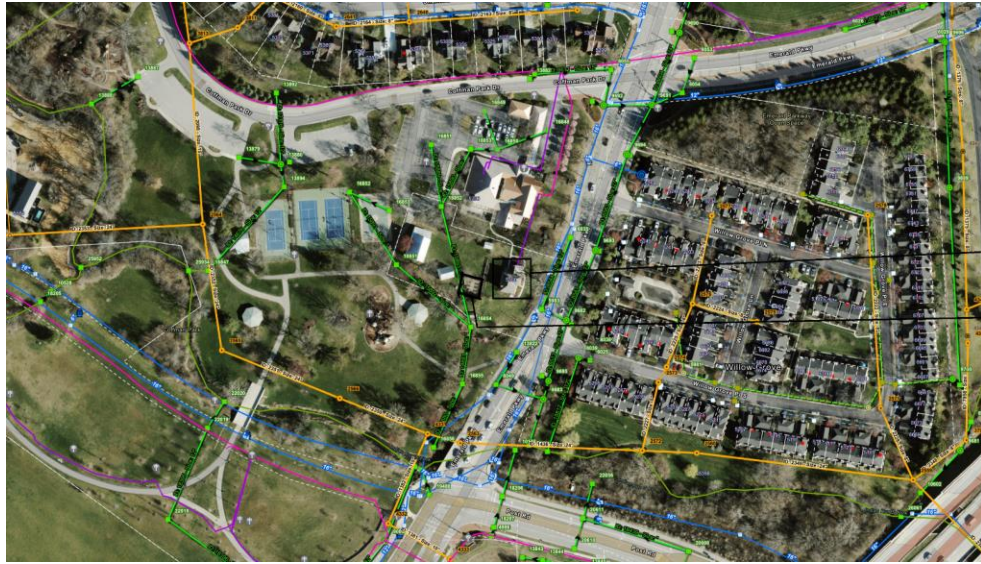

- Dublin Historical Society Building
- Location of Giving Garden Project
- Color Legend for Utilities:**
 - Water system
 - Storm water system
 - Sanitary system
 - Fiber / Dublin



- Dublin Department of Development Building
- Dublin Historical Society Building
- Location of Giving Garden Project
- Color Legend for Utilities:**
 - Water system
 - Storm water system
 - Sanitary system
 - Fiber / Dublin

Existing Beds in Giving Garden





- **Proposed Plan**

We are proposing to put 2 elevated beds on the northern side of the garden. These beds will have enough sunlight as they are elevated beds and will be a good addition to grow most herbs like cilantro, parsley, and rosemary, basil, green onions, chives etc.

Along with raised beds, will add new 6 beds by removing existing beds.



● Proposed Elevated Bed Designs

These are 2 elevated beds each with 8 feet long, 3 feet in width, 3.5 feet height and depth of 16 inches.

The depth of 16 inches would help to grow small to medium herb plants.

These beds will be filled with raised bed soil.

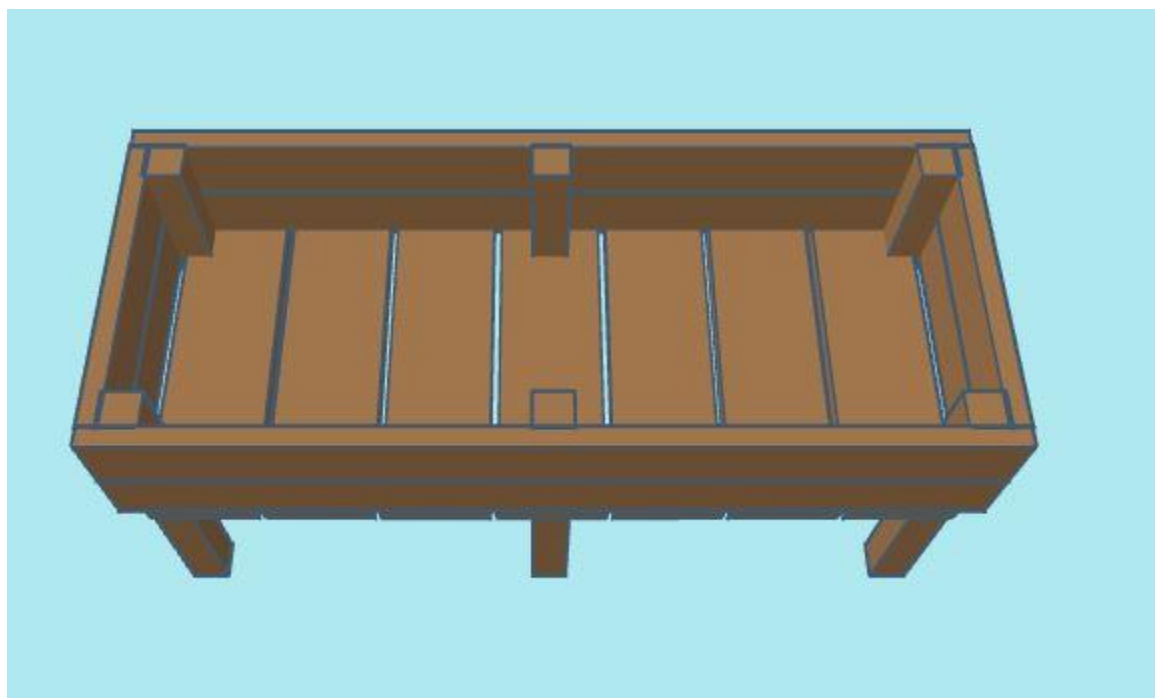
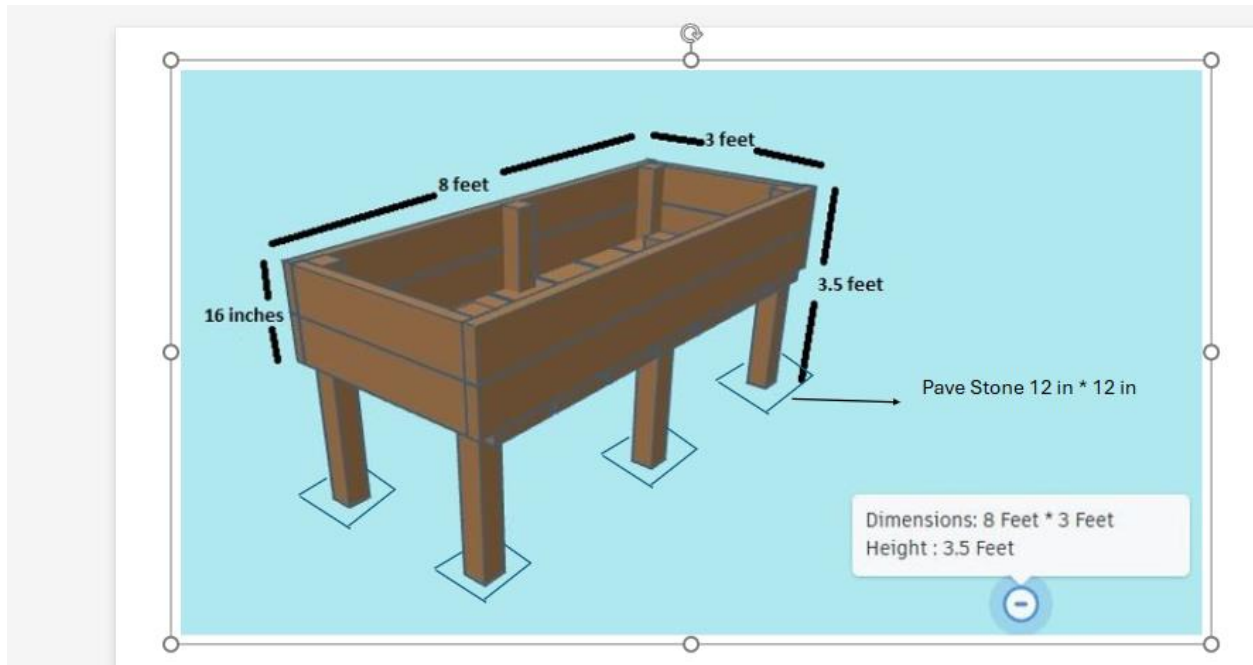

Example of Similar Elevated Bed



- **Proposed Raised Garden Bed Design**

Existing beds will be removed and new 6 raised beds will be added to the garden. Dimensions for each bed will be 8 * 4 Feet and will be 12 inches in height. New soil / compost will be added back to these beds along with existing soil from the raised beds.

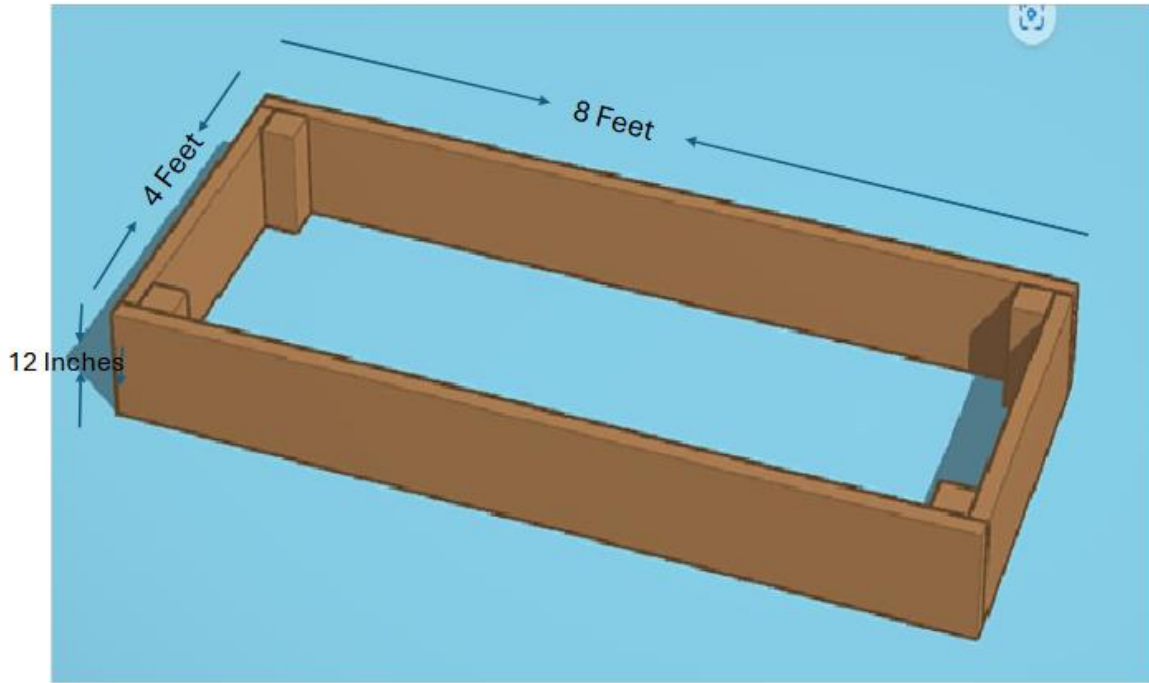

Example of Similar Raised Bed



● Material Required

Name	Dimension	Quantity	Estimated Cost
Cedar Lumber	4 inch * 4 Inch * 8 Feet	9	\$440.82
Cedar Lumber	2 Inch * 8 Inch * 8 Feet	12	\$599.88
Cedar Lumber	2 inch * 6 Inch * 8 feet	36	\$1122.48
Cedar Lumber	2 inch * 6 inch * 10 feet	11	\$296.89
Cedar Lumber	1 inch * 2 Inch * 8 feet	6	\$28.44
Structural Wood Screws	4 Inch	600	\$449.64
Galvanized Hardware Mesh	4* 25 Feet	1	\$47.31
Landscaping Fabric	4* 100 Feet	2	\$119.96
Concrete Patio Stone	12 inch * 12 Inch	12	\$22.56
Finished Nails	1.5 Inch	2000	\$11.88
Total Estimated Project Cost			\$3139.86

Note: Apart from above material, we will also require Raised Bed / Elevated Bed soil and compost for all 8 beds.

● Reference Links for Material Estimates

https://www.lowes.com/pl/lumber-composites/framing-lumber/dimensional-lumber/cedar/4294402500-4294671555

Order of Operations... Kubernetes Learnin... Welcome to Consul... Welcome to Consul... Meet - fgi-gasd-jyd SKATING (ICE) MERI... (function(){ docum... Gmail dra

Free Delivery Compare Compare Compare

Common Measurement (T x W)

- 2-in x 4-in (3)
- 2-in x 6-in (1)
- 4-in x 4-in (2)

Wood Species (1)

- Cedar (6)
- Pine (3)
- Southern yellow pine (12)
- Spruce pine fir (8)
- Whitewood (3)

[+ See All](#)

For Use With

Grade

Price



4-in x 4-in x 8-ft Cedar Green Lumber
\$48⁹⁸
3.8 ★★★★★ 36
Actual Dimensions: 3.75-in x 3.75-in x 8.0-ft
Wood Species: Cedar
Dressing: Rough
Pickup 24 Nearby at N.E. (9.8 mi. away)
Delivery to 43017



2-in x 4-in x 8-ft Cedar Green Lumber
\$21⁷⁸
3.9 ★★★★★ 37
Actual Dimensions: 1.75-in x 3.75-in x 8-ft
Wood Species: Cedar
Dressing: Rough
Pickup 63 Nearby at S.W. (12.7 mi. away)
Delivery to 43017



2-in x 4-in x 8-ft Cedar Gre
\$21⁷⁸
3.7 ★★★★★ 3
Actual Dimensions: 2-in x 4-in
Wood Species: Cedar
Drying Method: Green
Pickup 63 Nearby at S.W.
Delivery to 43017

Based on your search:



580

4 in. x 4 in. x 8 ft. Western Red Cedar Fence Post (2-Pack)

by **Outdoor Essentials** >

★★★★☆ (96)

- Cedar is naturally resistant to rot and decay
- Use cedar fence posts to build a 6 ft. tall fence
- Pack includes 2 cedar 8 foot fence posts

Nominal post height (ft.): 8 ft

6 ft 8 ft

\$94.49 /package

Pickup at Sawmill Deliverin

Ship to Store

Dec 18 - Dec 19

164 available

FREE

Deliv

Dec 1:

164 av

FREE

Add to Cart

[View Full Product Details](#)

- Common Measurement (T x W) (1)**
- 2-in x 4-in (3)
 - 2-in x 6-in (1)
 - 4-in x 4-in (2)
- Wood Species (1)**
- Cedar (1)
 - Pine (1)
 - Spruce pine fir (5)
 - Whitewood (1)
- For Use With**
- Availability**
- Show Model & Item Number



2-in x 6-in x 8-ft Cedar Kiln-dried Lumber

\$31.18

4.6 ★★★★★ 7

Actual Dimensions: 1.5-in x 5.5-in x 8-ft

Wood Species: Cedar

Dressing: S4S

Pickup Ready Today | 48 in Stock at [Dublin...](#)

Delivery to 43017 As soon as Today, Order by 2pm

MENARDS® Departments Weekly Flyer Search Sign In Cart

In Stock Today at LEWIS CENTER, OH Open until 9:00 PM Project Center Credit Programs Help Gifting Order Tracker Rebate Center

Home / Building Materials / Lumber & Boards / Dimensional Lumber

TOP SELLER!



2 x 6 x 10' Red Cedar S4S Lumber
 (Actual Size 1-1/2" x 5-1/2" x 10')
 Model Number: 1072846 | Menards® SKU: 1072846

Menards® Low Price! **\$26⁹⁹ each**

54 People have purchased this in the past week.

1 ADD TO CART

Additional Packaging/Handling Charges May Apply.

- #2 and Better Grade
- Appearance quality - virtually wane free
- The use of stainless steel, triple coated galvanized, or aluminum fasteners

Bring Your Project to Life with Menards® Design & Buy™

https://www.menards.com/main/building-materials/lumber-boards/dimensional-lumber/2-x-8-red-cedar-s4s-lumber/1072943/p-14444... SKATING (ICE) MERI... (function() docum... Gmail dragon dup

MENARDS® Departments Weekly Flyer Search Sign In Cart

In Stock Today at LEWIS CENTER, OH Open until 9:00 PM Project Center Credit Programs Help Gifting Order Tracker Rebate Center

Home / Building Materials / Lumber & Boards / Dimensional Lumber



2 x 8 x 8' Red Cedar S4S Lumber
 (Actual Size 1-1/2" x 7-1/4" x 8')
 Model Number: 1072943 | Menards® SKU: 1072943

Menards® Low Price! **\$49⁹⁹ each**

6 ADD TO CART

Increments of 6 are required. Please enter multiples of 6

Additional Packaging/Handling Charges May Apply.

- #2 and Better Grade
- Appearance quality - virtually wane free
- The use of stainless steel, triple coated galvanized, or aluminum fasteners

Bring Your Project to Life with Menards® Design & Buy™

Order of Operations... Kubernetes Learnin... Welcome to Consul... Welcome to Consul... Meet - fgi-gasd-jyd SKATING (ICE) MERI... (function){ docum...

FastenMaster
TimberLOK Structural Wood Screws - 4 inch wood screws with hex head - Black (50 Pack)
 ★★★★★ (1048) Questions & Answers (55)

1.2k

BULK PRICE ELIGIBLE **\$37.47** /box
 Buy 5 or more **\$31.85**
 Pay **\$12.47** after **\$25 OFF** your total new card. Apply for a Home Depot Consumer Card

- Structural wood screws for trusses
- 4 inch wood screws with hex head
- TimberLOK screws replace 3/8" lag bolts
- [View More Details](#)

Sawmill Store
 ✓ 5 in stock Aisle 16, Bay 014

Package Quantity: 50

Size: 3/16 in

Hurricane Clip & 10 Nails

0:05

6" TimberLOK requires no predrilling

- ✓ Install at 22½° angle
- ✓ 5 seconds

0:26

A H2.5 clip requires 10, 8D nails (specified by clip manufacturer)

Order of Operations... Kubernetes Learnin... Welcome to Consul... Welcome to Consul... Meet - fgi-gasd-jyd SKATING (ICE) MERI... (function){ docum...

amazon prime Deliver to Shailesh Dublin 43016 Tools & Home Improvement Search Amazon

All Rufus Same-Day Delivery Medical Care Prime Video Today's Deals Customer Service Best Sellers Amazon Basics Keep Shopping For Buy Again Amazon Home

Tools & Home Improvement Best Sellers Deals & Savings Gift Ideas Power & Hand Tools Lighting & Ceiling Fans Kitchen & Bath Fixtures Smart Home Shop by Room Launchpad Amazon Business

Hardware Cloth, 36in x 100ft, 1/2 inch 19Ga Hot Dipped Galvanized After Welding, by Agg... 4.7 ★★★★★ 696 \$119.99 prime

Tools & Home Improvement > Building Supplies > Building Materials > Decking & Fencing > Materials > Hardware Cloth

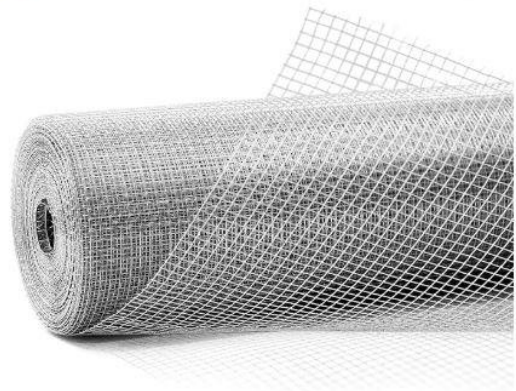

Fencer Wire 23 Gauge Galvanized Hardware Cloth with Mesh Size 1/4" x 1/4" (4 ft. x 25 ft.)

Brand: Fencer Wire
 4.7 ★★★★★ (1,004)

\$47.31

Pay ~~\$47.34~~ \$34.58 after using available Amazon Visa rewards points.

Size Name: 4 ft. x 25 ft.

4 ft. x 100 ft. \$152.89 (\$0.38 / Sq Ft)	2 ft. x 25 ft. \$27.38	2 ft. x 50 ft. \$45.19 (\$0.45 / Sq Ft)	2 ft. x 100 ft. 1 option from \$85.39	3 ft. x 5 ft. 1 option from \$19.99
3 ft. x 10 ft. \$20.71	3 ft. x 25 ft. \$39.49 (\$0.53 / Sq Ft)	3 ft. x 50 ft. \$59.42	3 ft. x 100 ft. \$102.59 (\$0.34 / Sq Ft)	4 ft. x 25 ft. \$47.31
4 ft. x 50 ft. \$85.49 (\$0.43 / Sq Ft) \$99.99				





Dublin Lowe's 9 PM 43017

What can we help you find?

Sign In

Shop All Installations Savings Holiday Decorations Appliances Bathroom Building Supplies Flooring Gift Zone

Lawn & Garden / Pavers & Retaining Walls / Stones & Pavers / Pavers & Stepping Stones

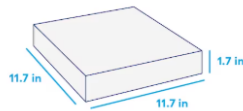

Product is for example only.

Bestseller 5k+ bought last week

12-in L x 12-in W x 2-in H Square Gray Concrete Patio Stone

Item #19183 | Model #104601999

Shop the Collection

4.5 3969

\$1.88 or \$1.69 Buy 168 or More 10% Off

Manufacturer Color/Finish: Gray



#1 Home Improvement Retailer



Sawmill 9PM 43017

What can we help you find today?



Shop All

Services

DIY

Outdoors / Garden Center / Landscaping Supplies / Landscape Fabric

Internet # 302802172 Model # VPMN

Best Seller

2.3k

Vigoro

4 ft. x 100 ft. Heavy Duty Matrix Grid Weed Control Landscape Fabric

4.5 (1708) Questions & Answers (158)



BULK PRICE \$59.98

Buy 4 or more \$53.98

Pay \$34.98 after \$25 OFF your total qualifying new card. Apply for a Home Depot Consumer Card

- Matrix Grid landscape fabric is 2x stronger ar
- Controls weed growth while optimizing air an
- Heavy duty fabric great for hardscape, landsc
- [View More Details](#)

Sawmill Store

8 in stock Aisle 59, Bay EC2



Sawmill 9PM 43017 What can we help you find today?

Shop All Services DIY Log In

Hardware / Fasteners / Collated Fasteners / Collated Finishing Nails

Internet # 100165942 Model # 650212 Store SK

Top Rated

118

Contains 20 hundred units

SPECIAL BUY \$11.88 (59c /100 units) Was ~~\$19.84~~ Save \$1.96 (14%)

Paslode

1 in. x 18-Gauge Galvanized Straight Finish Nail (2,000-Pack)

★★★★★ (904) Questions & Answers (27)



- Paslode 18Ga Brad nails reduce splitting fine trim and mold
- Paslode 18Ga Brad nails for door, crown, base, and chair
- Paslode 18 gauge Brad galvanized nails for corrosion resist
- [View More Details](#)

Sawmill Store

✓ 2 in stock Aisle 13, Bay 013

Fastener Length (in.): 1.25



Departments Weekly Flyer Search Sign In Cart

In Stock Today at LEWIS CENTER, OH Open until 9:00 PM

Project Center Credit Programs Help Gifting Order Tracker Rebate Center

Home / Building Materials / Lumber & Boards / Boards



Add To List

1 x 2 x 8' Red Cedar Board

(Actual Size: 13/16" x 1-1/2" x 8')

Model Number: 1071148 | Menards® SKU: 1071148

Menards® Low Price!

\$ **4.74** each

- 1 +

ADD TO CART

! Additional Packaging/Handling Charges May Apply.