

SHANNON PARK SOH3625



COLOCATION
6790 COFFMAN RD
DUBLIN, OH 43017
WSOWP0042545
FA #: 15758363
USID: 318661
MONOPOLE

188 INVERNESS DRIVE WEST
 SUITE 400
 ENGLEWOOD, CO 80112

6615 TOWPATH ROAD
 EAST SYRACUSE, NY 13057

520 South Main Street, Suite 2531
 Akron, OH 44311
 330.572.2100 Fax 330.572.2101
 Copyright: Glauz, Pyle, Schomer, Burns & DeHaven, Inc. 2025

GPD JOB #:	2025705.79
DRAWN BY:	ACM
CHECKED BY:	LJB
RFDS:	25309

REV	DATE	DESCRIPTION
0	08/27/2025	FOR CONSTRUCTION
C	08/15/2025	REV. PER COMMENTS
B	08/12/2025	REV. PER COMMENTS
A	06/05/2025	ISSUED FOR REVIEW

IT IS A VIOLATION OF LAW FOR ANY PERSON, UNLESS THEY ARE ACTING UNDER THE DIRECTION OF A LICENSED PROFESSIONAL ENGINEER, TO ALTER THIS DOCUMENT.

SHANNON PARK
 SOH3625
 6790 COFFMAN RD
 DUBLIN, OH 43017
 COLOCATION

SHEET TITLE
 TITLE SHEET

SHEET NUMBER
TS-1

SCOPE OF WORK SUMMARY

GROUND SCOPE OF WORK

- REMOVE EXISTING OTHER CARRIER DECOMMISSIONED EQUIPMENT
- INSTALL (1) WUC (WALK UP CABINET)
- INSTALL (1) 30KW DIESEL GENERATOR W/145 GAL TANK
- INSTALL SERVICE CONDUITS AND CONDUCTORS FROM UTILITY H-FRAME TO AT&T WUC
- INSTALL GENERATOR CIRCUITS FROM WUC TO GENERATOR
- INSTALL NEW FIBER BOXES
- INSTALL NEW METER AND DISCONNECT
- INSTALL NEW ICE BRIDGE AND ICE BRIDGE FOUNDATIONS
- INSTALL NEW GROUNDING SYSTEM

TOWER SCOPE OF WORK

- INSTALL ANTENNA MOUNTING SUPPORT STRUCTURE ON TOWER
- INSTALL (9) NEW ANTENNAS
- INSTALL (9) NEW RRUS
- INSTALL (4) NEW DC TRUNKS
- INSTALL (2) NEW FIBER TRUNKS

Planning Number	Planning Status	Product Group	Product Sub Group	Job ID	Oracle P/N	Spectrum
ER_R09P-24-2940	Issued	LTE Not Carrier	LTE 4C	WSOWP0042510	3457A1DP1V	700 MHz UPPER D (10 MHz) Band 14
ER_R09P-24-2920	Issued	5G NR Radio	5G NR (DR) CBAND	WSOWP0042552	3457A1DQ87	CBAND 4 GHz 84-88 (4x12) (80MHz) Band 47
ER_R09P-24-2915	Issued	New Site	LTE Only 1C	WSOWP0042545	3457A1DQ8C	700 MHz OFFSET LOWER 3C (10 MHz) E-UTRA BAND 17
ER_R09P-24-2929	Issued	LTE Not Carrier	LTE 3C	WSOWP0042770	3457A1DP7N	PCS MHz-A1-A4-A5-L15 MHz E-UTRA Band 2

GENERAL NOTES

THE FACILITY IS UNMANNED AND NOT FOR HUMAN HABITATION. A TECHNICIAN WILL VISIT THE SITE AS REQUIRED FOR ROUTINE MAINTENANCE. THE PROJECT WILL NOT RESULT IN ANY SIGNIFICANT DISTURBANCE OR EFFECT ON DRAINAGE. NO SANITARY SEWER SERVICE, POTABLE WATER, OR TRASH DISPOSAL IS REQUIRED AND NO COMMERCIAL SIGNAGE IS PROPOSED.

DRAWING INDEX

SHEET NO.	SHEET TITLE
TS-1	TITLE SHEET
	EASEMENT SURVEY (REFERENCE ONLY)
C-1	SITE PLAN
C-1.1	EXISTING SITE PLAN
C-1.2	PROPOSED SITE PLAN
C-2	EQUIPMENT LAYOUT
C-3	EQUIPMENT SPECIFICATIONS
C-4	EQUIPMENT DETAILS
C-5	SIGNAGE DETAILS
C-6	CONCRETE WORK AND STRUCTURAL NOTES
C-7	CONCRETE PAD DETAILS AND FOUNDATIONS NOTES
T-1	TOWER ELEVATION, ANTENNA AND COAX PLANS
T-1.1	ANTENNA AND COAX SCHEDULE
T-2	EQUIPMENT DETAILS
T-3	EQUIPMENT DETAILS
T-4	EQUIPMENT DETAILS
T-5	EQUIPMENT DETAILS
T-6	PLUMBING DIAGRAM
T-7	PLUMBING DIAGRAM
T-8	PLUMBING DIAGRAM
E-1	UTILITY PLAN
E-2	ELECTRICAL AC ONE-LINE DIAGRAM
E-3	GENERAL ELECTRICAL NOTES
E-4	AC PANEL SCHEDULE AND NOTES
E-5	ELECTRICAL DETAILS
G-1	GROUNDING SITE PLAN AND NOTES
G-2	ANTENNA GROUNDING PLAN
G-3	GROUNDING DETAILS
G-4	GROUNDING DETAILS
G-5	ELECTRICAL AND GROUNDING NOTES
GN-1	LEGEND AND ABBREVIATIONS
GN-2	GENERAL CONSTRUCTION NOTES
GN-3	GENERAL CONSTRUCTION NOTES

11"x17" PLOT WILL BE HALF SCALE UNLESS OTHERWISE NOTED

CONTRACTOR SHALL VERIFY ALL PLANS, EXISTING DIMENSIONS, AND CONDITIONS ON THE JOB SITE, AND SHALL IMMEDIATELY NOTIFY THE ENGINEER IN WRITING OF ANY DISCREPANCIES BEFORE PROCEEDING WITH THE WORK.

CALL OHIO ONE CALL (800) 362-2764
 CALL 3 WORKING DAYS BEFORE YOU DIG!

ENGINEERING

ALL WORK SHALL BE PERFORMED AND MATERIALS INSTALLED IN ACCORDANCE WITH THE CURRENT EDITIONS OF THE FOLLOWING CODES AS ADOPTED BY THE LOCAL GOVERNING AUTHORITIES. NOTHING IN THESE PLANS IS TO BE CONSTRUED TO PERMIT WORK NOT CONFORMING TO THESE CODES:

CODE TYPE	CODE
BUILDING	2024 OHIO BUILDING CODE
	2021 IBC W/ STATE AMENDMENTS
MECHANICAL	2024 OHIO MECHANICAL CODE
	2021 IMC W/ STATE AMENDMENTS
ELECTRICAL	2023 NFPA 70 (NEC)

SITE INFORMATION

PROPERTY OWNER:	BD OF EDUCATION OF THE DUBLIN CITY SCHOOL DISTRICT
ADDRESS:	5175 EMERALD PKWY DUBLIN, OH 43017
SITE ADDRESS:	6790 COFFMAN RD DUBLIN, OH 43017
FA:	15758363
MONOPOLE OWNER:	CROWN CASTLE 875388
CELL SITE RF MODIFICATIONS IMM #:	WSOWP0042545
COUNTY:	FRANKLIN
LATITUDE (NAD83):	40° 06' 35.39" N (40.1098310)
LONGITUDE (NAD83):	-83° 07' 41.04" W (-83.1280670)
GROUND ELEVATION:	±888 AMSL
ZONING JURISDICTION:	CITY OF DUBLIN
ZONING DISTRICT:	R RURAL DISTRICT
PARCEL NUMBER:	273-000325
OCCUPANCY GROUP:	U
CONSTRUCTION TYPE:	V-B
POWER COMPANY:	AEP (800) 672-2231
TELEPHONE COMPANY:	AT&T (800) 288-2020
SITE ACQUISITION MANAGER:	PYRAMID NETWORK SERVICES (315) 701-1300
CONSTRUCTION MANAGER:	TBD TBD
RF ENGINEER:	TBD

CONTACT INFORMATION

GPD GROUP GLAUZ, PYLE, SCHOMER, BURNS & DEHAVEN, INC.
 520 SOUTH MAIN ST, SUITE 2531
 AKRON, OH 44311
 CONTACT: TRACI PREBLE
 E-MAIL: TPREBLE@GPDGROUP.COM

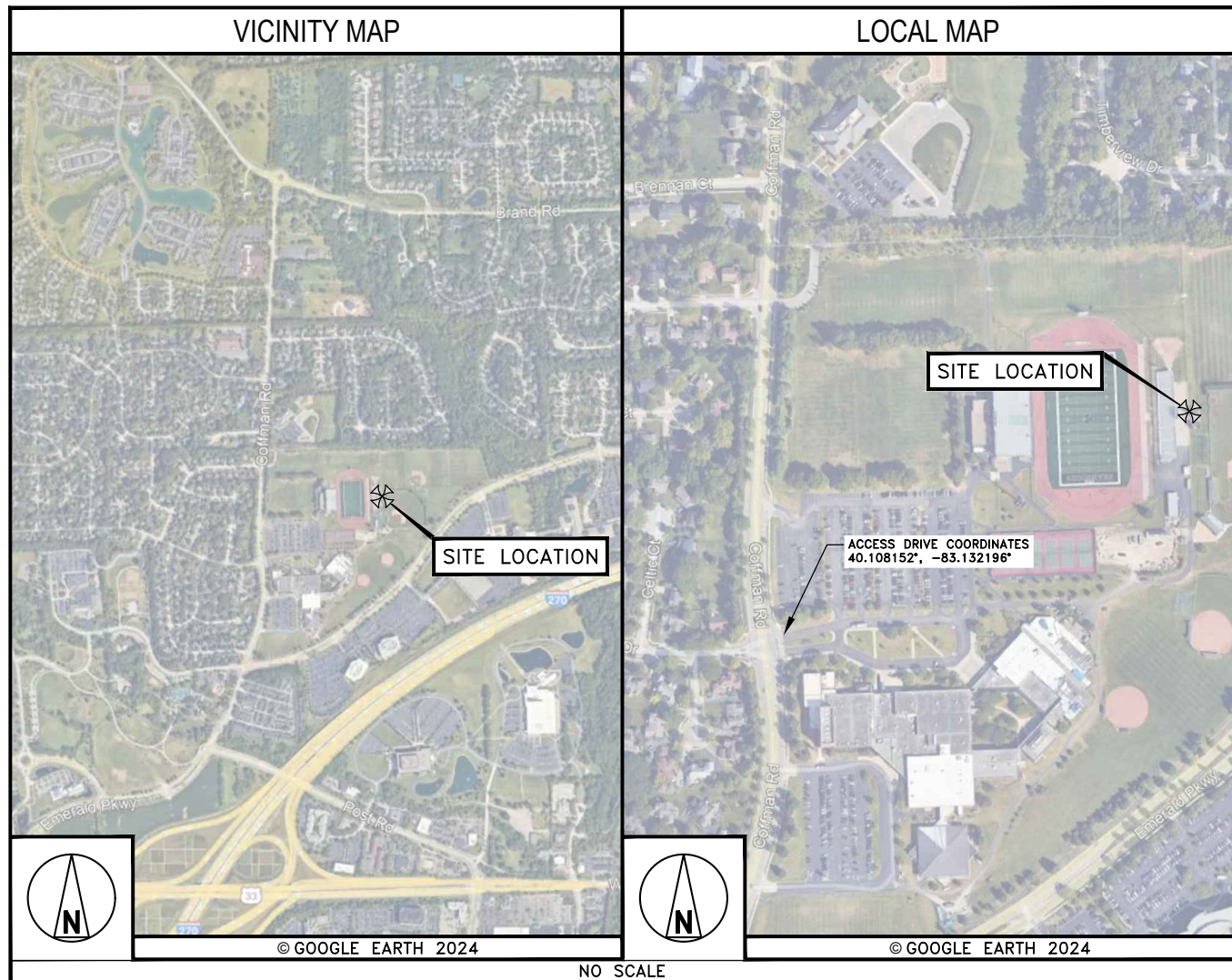

NOTES

1. CONTRACTOR SHALL FIELD VERIFY ALL DIMENSIONS.
2. ANTENNAS AND MOUNTS OMITTED FOR CLARITY.
3. SITE PLAN DISCLAIMER: THE EXISTING INFORMATION SHOWN IN THESE PLANS HAVE BEEN BASED ON EXISTING SITE INFORMATION PROVIDED BY OTHERS. THE GPD GROUP HAS NOT COMPLETED A SITE SURVEY AND THEREFORE MAKES NO CLAIMS AS TO THE ACCURACY OF INFORMATION DEPICTED ON THIS SHEET.



AT&T
 188 INVERNESS DRIVE WEST
 SUITE 400
 ENGLEWOOD, CO 80112



PYRAMID
 Network Services, LLC
 6615 TOWPATH ROAD
 EAST SYRACUSE, NY 13057



GPD GROUP
 Claus, Pyle, Schomer, Burns & DeHaven, Inc.
 520 South Main Street, Suite 2531
 Akron, OH 44311
 330.572.2100 Fax 330.572.2101
Copyright: Claus, Pyle, Schomer, Burns & DeHaven, Inc. 2025

GPD JOB #:	2025705.79
DRAWN BY:	ACM
CHECKED BY:	LJB
RFDS:	25309

REV	DATE	DESCRIPTION
0	08/27/2025	FOR CONSTRUCTION
C	08/15/2025	REV. PER COMMENTS
B	08/12/2025	REV. PER COMMENTS
A	06/05/2025	ISSUED FOR REVIEW



STATE OF OHIO
 CHRISTOPHER J. SCHEKS
 E - 78306
 REGISTERED PROFESSIONAL ENGINEER
 08/27/2025

IT IS A VIOLATION OF LAW FOR ANY PERSON, UNLESS THEY ARE ACTING UNDER THE DIRECTION OF A LICENSED PROFESSIONAL ENGINEER, TO ALTER THIS DOCUMENT.

SHANNON PARK
 SOH3625
 6790 COFFMAN RD
 DUBLIN, OH 43017
 COLOCATION

SHEET TITLE
SITE PLAN

SHEET NUMBER
C-1

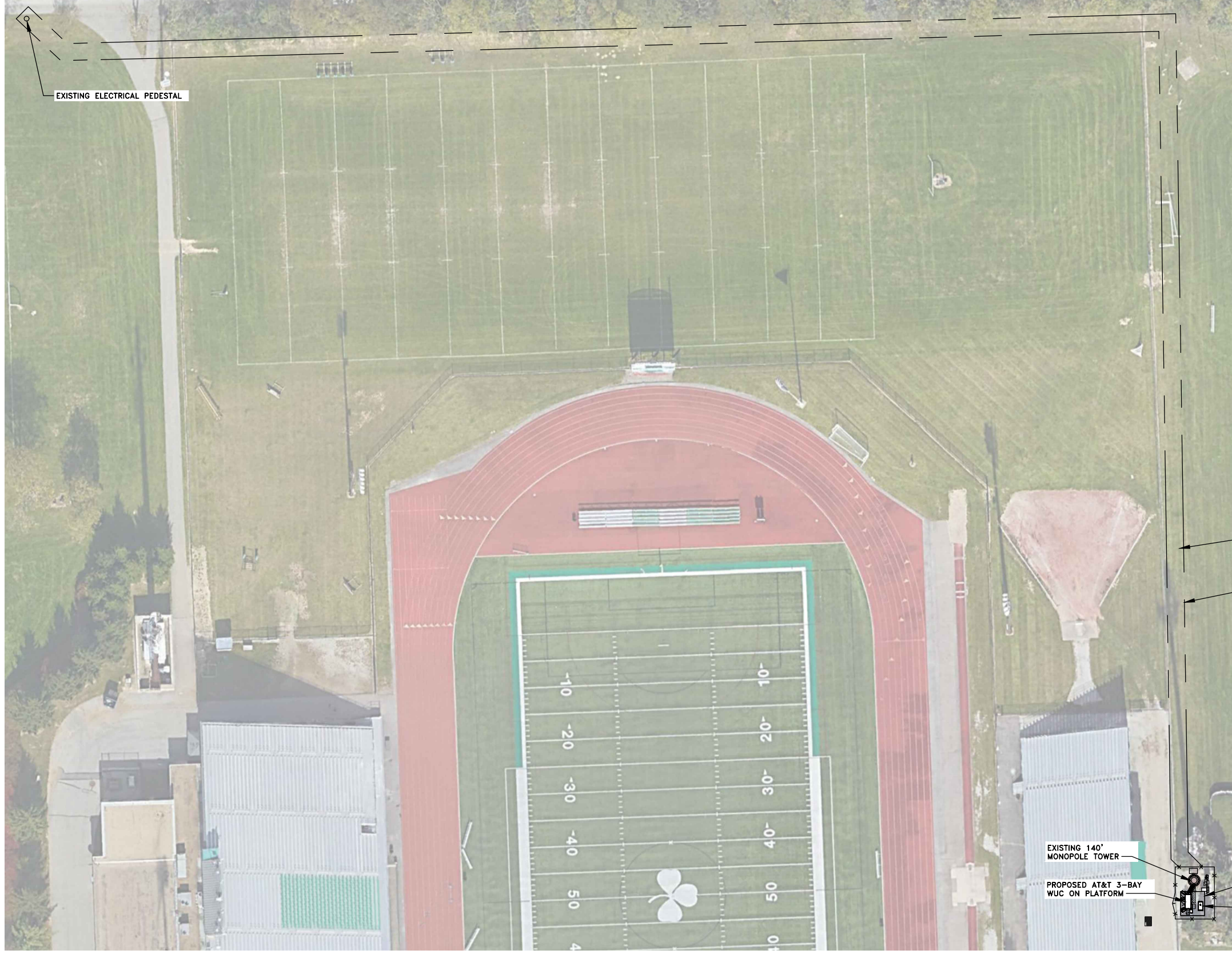

PROPOSED UNDERGROUND CONDUIT FOR POWER
 -ROUTED WITHIN EXISTING UTILITY EASEMENT (±1170)

EXISTING 10' WIDE UTILITY EASEMENT
 -REFER TO PREVIOUS SURVEY BY FIRST GROUP ENGINEERING INC. DATED 12/14/06 FOR DESCRIPTION OF EASEMENT

EXISTING 140' MONOPOLE TOWER

PROPOSED AT&T 3-BAY WUC ON PLATFORM

PROPOSED AT&T 14'-0"x14'-0" LEASE AREA

PROPOSED AT&T 30kW COMPACT DIESEL GENERATOR W/ 145 GALLON TANK ON CONCRETE PAD

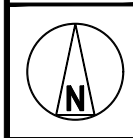

SITE PLAN

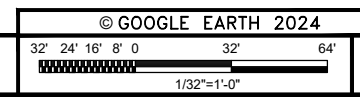

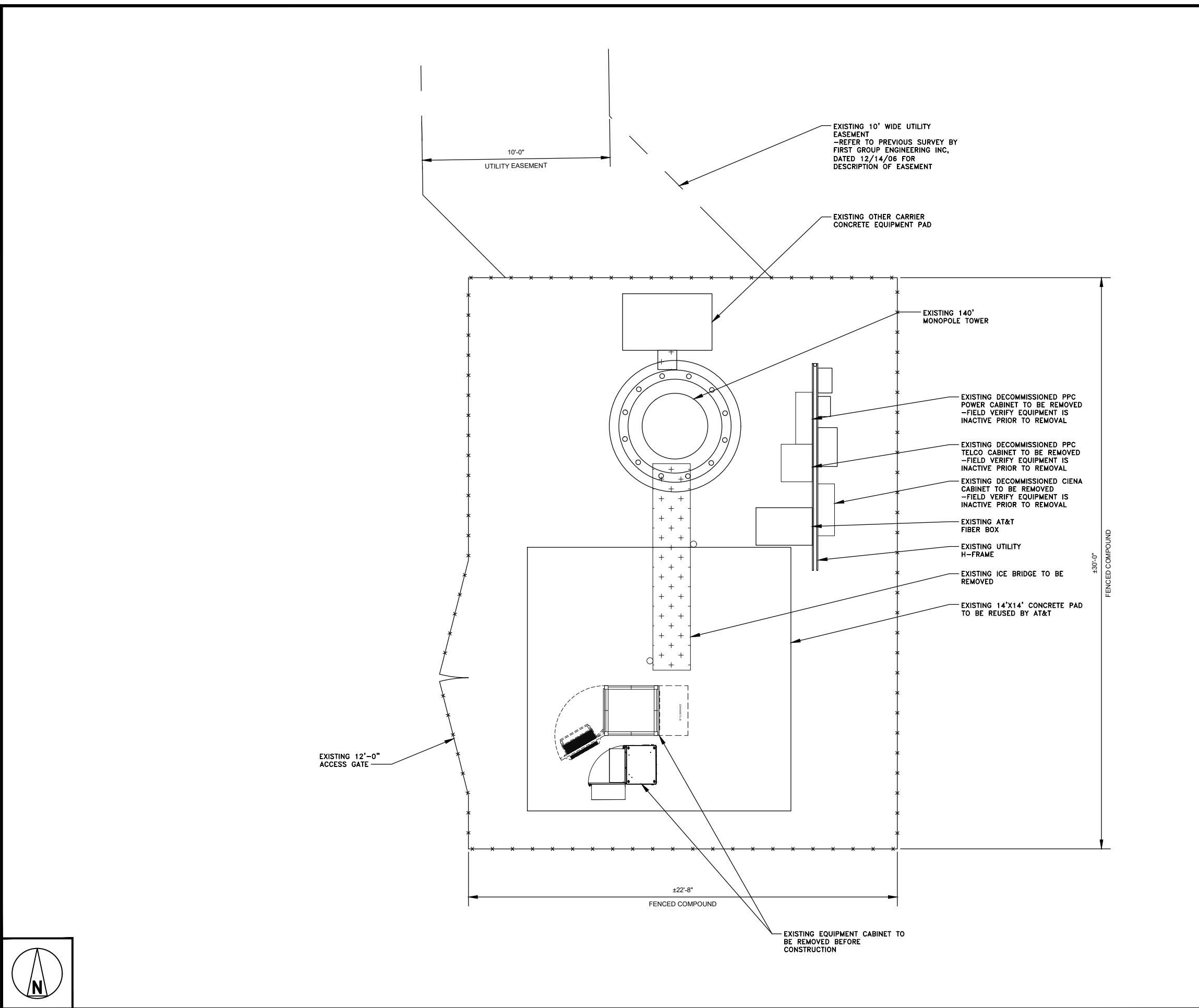

NOTES

1. CONTRACTOR SHALL FIELD VERIFY ALL DIMENSIONS.
2. ANTENNAS AND MOUNTS OMITTED FOR CLARITY.
3. SITE PLAN DISCLAIMER: THE EXISTING INFORMATION SHOWN IN THESE PLANS HAVE BEEN BASED ON EXISTING SITE INFORMATION PROVIDED BY OTHERS. THE GPD GROUP HAS NOT COMPLETED A SITE SURVEY AND THEREFORE MAKES NO CLAIMS AS TO THE ACCURACY OF INFORMATION DEPICTED ON THIS SHEET.

188 INVERNESS DRIVE WEST
SUITE 400
ENGLEWOOD, CO 80112

6615 TOWPATH ROAD
EAST SYRACUSE, NY 13057

520 South Main Street, Suite 2531
Akron, OH 44311
330.572.2100 Fax 330.572.2101
Copyright: Glau, Pyle, Schomer, Burns & DeHaven, Inc. 2025

GPD JOB #:	2025705.79
DRAWN BY:	ACM
CHECKED BY:	LJB
RFDS:	25309

REV	DATE	DESCRIPTION
0	08/27/2025	FOR CONSTRUCTION
C	08/15/2025	REV. PER COMMENTS
B	08/12/2025	REV. PER COMMENTS
A	06/05/2025	ISSUED FOR REVIEW

IT IS A VIOLATION OF LAW FOR ANY PERSON, UNLESS THEY ARE ACTING UNDER THE DIRECTION OF A LICENSED PROFESSIONAL ENGINEER, TO ALTER THIS DOCUMENT.

SHANNON PARK
SOH3625
6790 COFFMAN RD
DUBLIN, OH 43017
COLOCATION

SHEET TITLE
EXISTING SITE PLAN

SHEET NUMBER
C-1.1

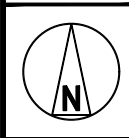

EXISTING SITE PLAN

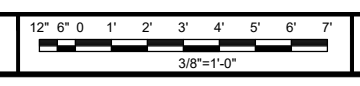

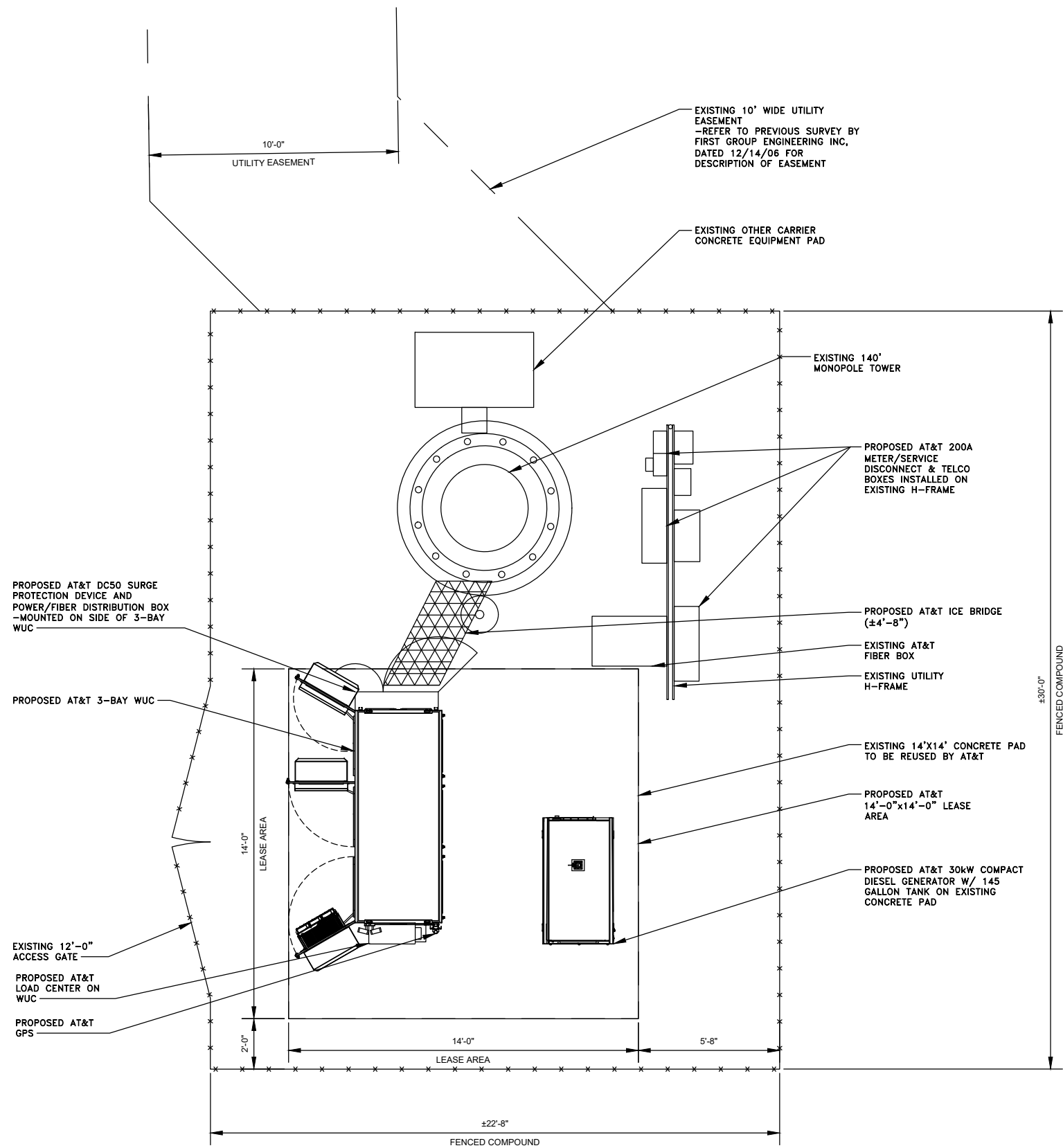

- NOTES**
1. CONTRACTOR SHALL FIELD VERIFY ALL DIMENSIONS.
 2. ANTENNAS AND MOUNTS OMITTED FOR CLARITY.
 3. SITE PLAN DISCLAIMER: THE EXISTING INFORMATION SHOWN IN THESE PLANS HAVE BEEN BASED ON EXISTING SITE INFORMATION PROVIDED BY OTHERS. THE GPD GROUP HAS NOT COMPLETED A SITE SURVEY AND THEREFORE MAKES NO CLAIMS AS TO THE ACCURACY OF INFORMATION DEPICTED ON THIS SHEET.
 4. CONTRACTOR TO ENSURE ALL NEC WORKING SPACE CLEARANCES ARE MET

188 INVERNESS DRIVE WEST
SUITE 400
ENGLEWOOD, CO 80112

6615 TOWPATH ROAD
EAST SYRACUSE, NY 13057

520 South Main Street, Suite 2531
Akron, OH 44311
330.572.2100 Fax 330.572.2101
Copyright: Glauk, Pyle, Schomer, Burns & DeHaven, Inc. 2025

GPD JOB #:	2025705.79
DRAWN BY:	ACM
CHECKED BY:	LJB
RFDS:	25309

REV	DATE	DESCRIPTION
0	08/27/2025	FOR CONSTRUCTION
C	08/15/2025	REV. PER COMMENTS
B	08/12/2025	REV. PER COMMENTS
A	06/05/2025	ISSUED FOR REVIEW

STATE OF OHIO
REGISTERED PROFESSIONAL ENGINEER
CHRISTOPHER J. SCHEKS
E - 78306
08/27/2025

IT IS A VIOLATION OF LAW FOR ANY PERSON, UNLESS THEY ARE ACTING UNDER THE DIRECTION OF A LICENSED PROFESSIONAL ENGINEER, TO ALTER THIS DOCUMENT.

SHANNON PARK
SOH3625
6790 COFFMAN RD
DUBLIN, OH 43017
COLOCATION

SHEET TITLE
PROPOSED SITE PLAN

SHEET NUMBER
C-1.2

PROPOSED SITE PLAN

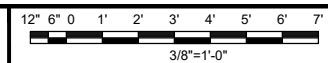

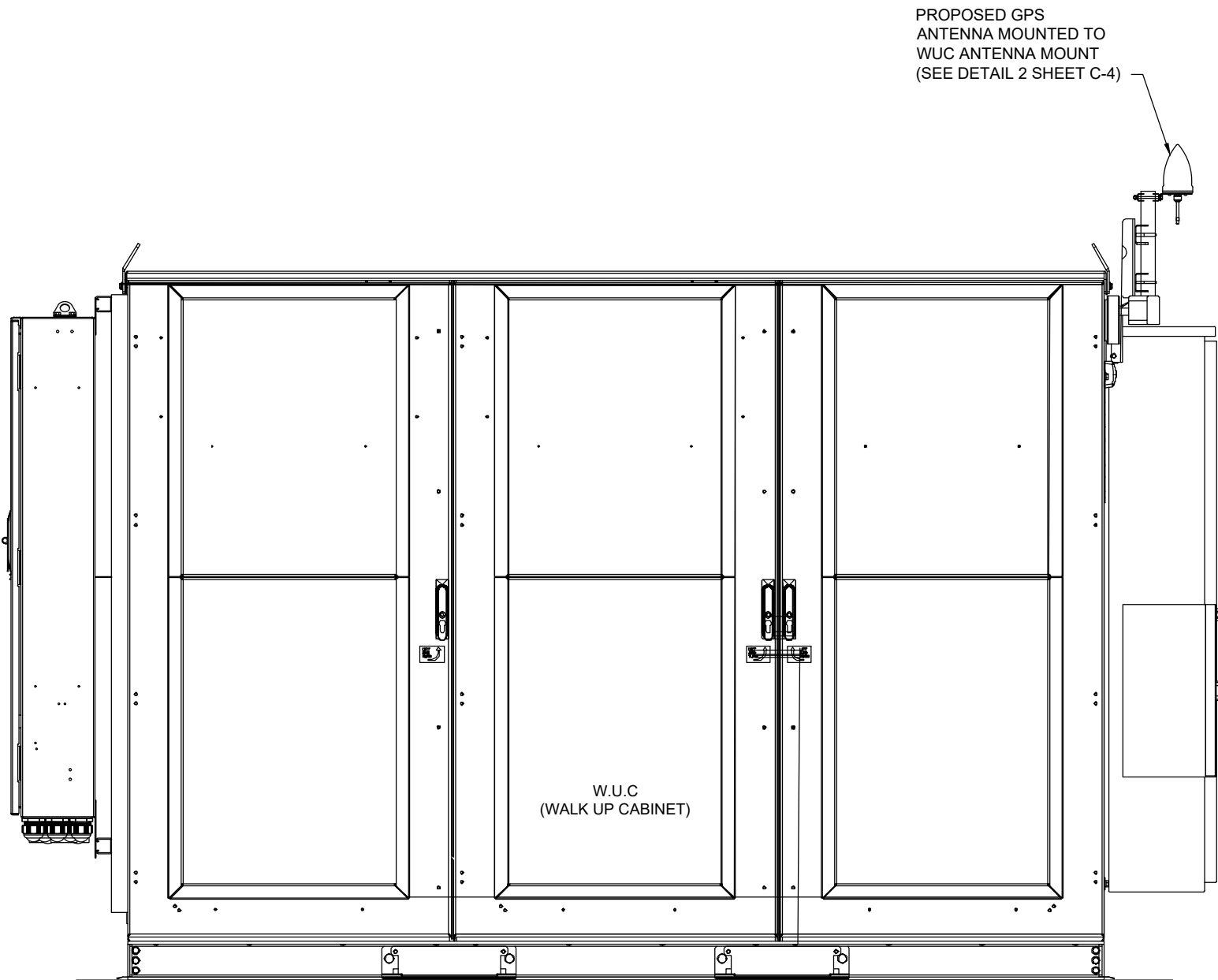

1. CONTRACTOR SHALL FIELD VERIFY ALL DIMENSIONS.
2. CONTRACTOR SHALL MAINTAIN A 10'-0" MINIMUM SEPARATION BETWEEN THE PROPOSED GPS ANTENNA AND TRANSMITTING ANTENNAS.
3. CONTRACTOR SHALL INSTALL ALL CABINET PARTS SHIPPED LOOSE. (SEE CABINET MANUFACTURER DRAWINGS & SPECS)
4. CABINET SHIPPED WITH INTERIOR COMPLETE. FIELD VERIFY UPON DELIVERY TO SITE AND CONTACT CONSTRUCTION MANAGER IF ANY INTERIOR ITEMS ARE NOT PRESENT.
5. CONTRACTOR SHALL REFER TO "NETSURE X701 WALK-UP-CABINET (WUC): DESCRIPTION AND INSTALLATION MANUAL, REVISION G" ©2023 BY VERTIV FOR PRIMARY & ALTERNATIVE INSTALLATION PROCEDURES, AS NECESSARY.



188 INVERNESS DRIVE WEST
SUITE 400
ENGLEWOOD, CO 80112



6615 TOWPATH ROAD
EAST SYRACUSE, NY 13057

GPD JOB #:	2025705.79
DRAWN BY:	ACM
CHECKED BY:	LJB
RFDS:	25309

REV	DATE	DESCRIPTION
0	08/27/2025	FOR CONSTRUCTION
C	08/15/2025	REV. PER COMMENTS
B	08/12/2025	REV. PER COMMENTS
A	06/05/2025	ISSUED FOR REVIEW

REFERENCE
ONLY

IT IS A VIOLATION OF LAW FOR ANY PERSON, UNLESS THEY ARE ACTING UNDER THE DIRECTION OF A LICENSED PROFESSIONAL ENGINEER, TO ALTER THIS DOCUMENT.

SHANNON PARK
SOH3625
6790 COFFMAN RD
DUBLIN, OH 43017
COLOCATION

SHEET TITLE
EQUIPMENT
LAYOUT

SHEET NUMBER
C-2



188 INVERNESS DRIVE WEST
SUITE 400
ENGLEWOOD, CO 80112



6615 TOWPATH ROAD
EAST SYRACUSE, NY 13057

GPD JOB #: 2025705.79

DRAWN BY: ACM

CHECKED BY: LJB

RFDS: 25309

REV	DATE	DESCRIPTION
0	08/27/2025	FOR CONSTRUCTION
C	08/15/2025	REV. PER COMMENTS
B	08/12/2025	REV. PER COMMENTS
A	06/05/2025	ISSUED FOR REVIEW

REFERENCE ONLY

IT IS A VIOLATION OF LAW FOR ANY PERSON, UNLESS THEY ARE ACTING UNDER THE DIRECTION OF A LICENSED PROFESSIONAL ENGINEER, TO ALTER THIS DOCUMENT.

SHANNON PARK
SOH3625
6790 COFFMAN RD
DUBLIN, OH 43017
COLOCATION

SHEET TITLE
EQUIPMENT
SPECIFICATIONS

SHEET NUMBER

C-3

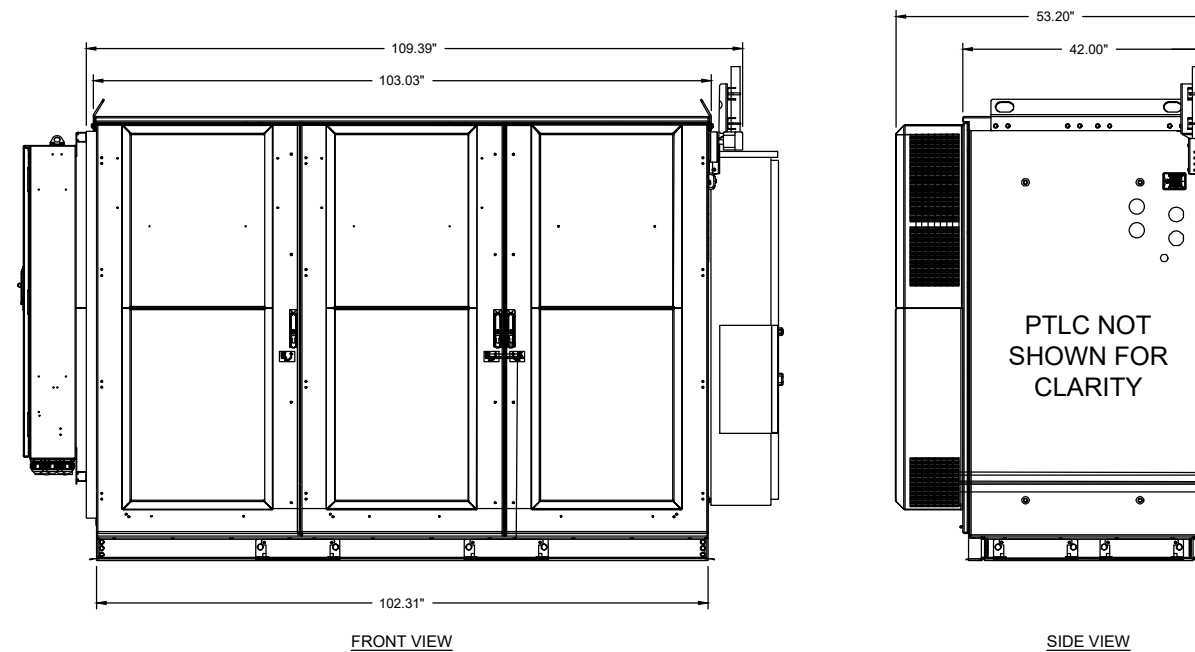

WEIGHT
APPROX. 4442LB (W/ EQUIPMENT)

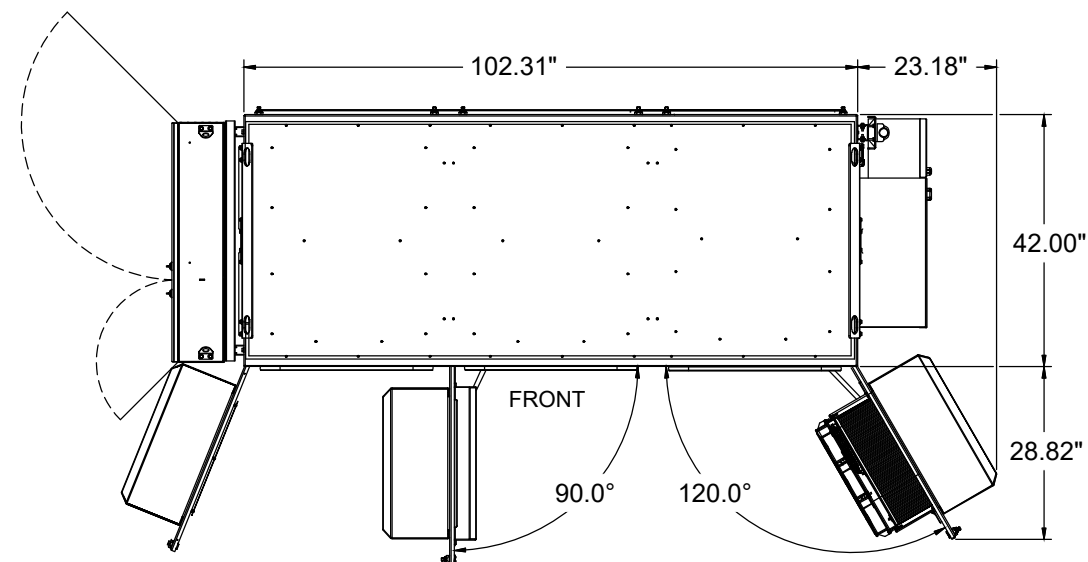

NETSURE X701 WALK UP CABINET

NO SCALE

2

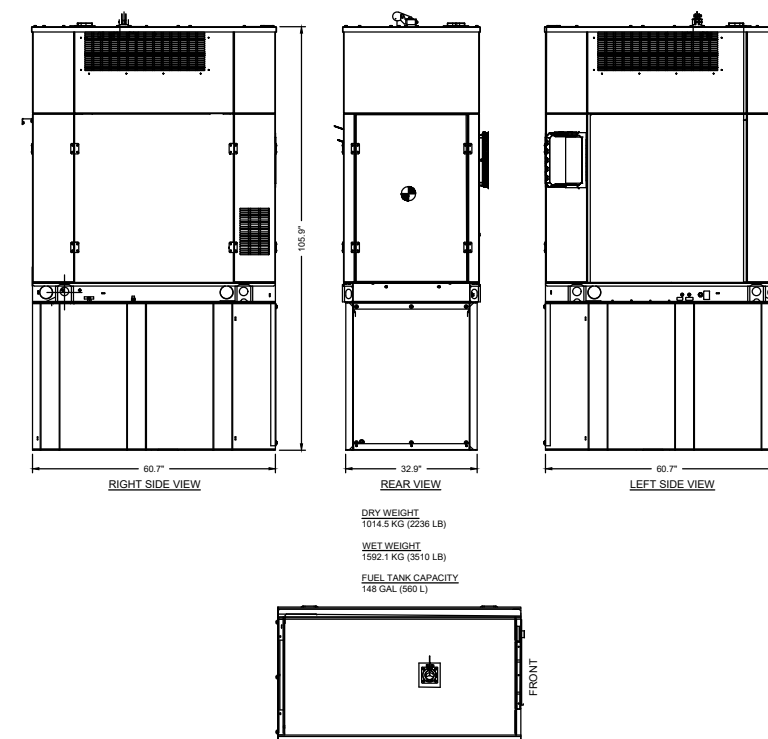

DRY WEIGHT
1014.5 KG (2236 LB)
WET WEIGHT
1992.1 KG (4391 LB)
FUEL TANK CAPACITY
148 GAL (560 L)

NETSURE X701 WALK UP CABINET

NO SCALE

1

GENERAC SDC030 | AC DIESEL
GENERATOR

NO SCALE

3



DETAIL NOT USED

NO SCALE

1

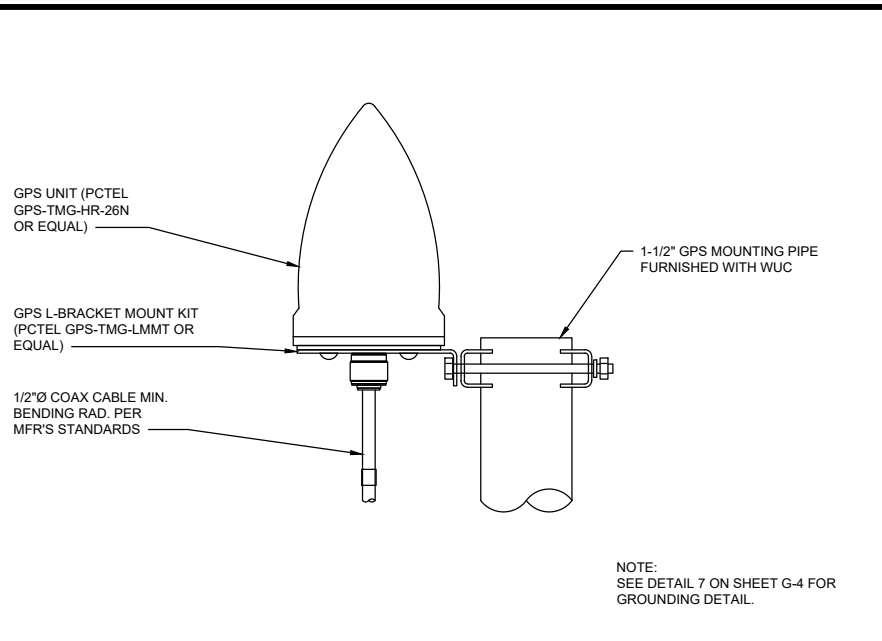

GPS ANTENNA DETAIL

NO SCALE

2

NOTES

- IT IS CRITICAL THAT THE GPS ANTENNA IS MOUNTED SUCH THAT IT IS WITHIN 2 DEGREES OF VERTICAL AND THE BASE OF THE ANTENNA IS WITHIN 2 DEGREES OF LEVEL.
- DO NOT SWEEP TEST GPS ANTENNA.
- PLACE PROPOSED GPS ANTENNA A MIN. OF 10' (3 METER) HORIZONTALLY FROM ALL EXISTING TRANSMITTING ANTENNAS.
- THE GPS ANTENNA MOUNT IS DESIGNED TO FASTEN TO A STANDARD 3/4" DIAMETER, SCHEDULE 40, GALVANIZED STEEL OR STAINLESS STEEL PIPE. THE PIPE MUST NOT BE THREADED AT THE ANTENNA MOUNT END. THE PIPE SHALL BE CUT TO THE REQUIRED LENGTH (MINIMUM OF 18") USING A HAND OR ROTARY PIPE CUTTER TO ASSURE A SMOOTH AND PERPENDICULAR CUT. A HACK SAW SHALL NOT BE USED. THE CUT PIPE END SHALL BE DEBURRED AND SMOOTH EDGES IN ORDER TO SEAL AGAINST THE NEOPRENE GASKET ATTACHED TO THE ANTENNA MOUNT.

GPS SPECIFICATIONS

NO SCALE

3

RAYCAP DC50-48-60-96-50F

DIMENSIONS, HxWxD: 52.24"x40.0"x9.00"
(mm) 1327x1016x229mm
TOTAL WEIGHT: 165.0 lbs



SURGE SPECIFICATIONS

NO SCALE

4

NOTES

- CONTRACTOR SHALL CONFIRM THE DEPTH OF THE ICE BRIDGE DRILLED PIER FOUNDATION, IF THE TOWER PAD FOUNDATION DEPTH IS LESS THAN THE STANDARD SHOWN.

ICE BRIDGE DETAIL NOTES

NO SCALE

5

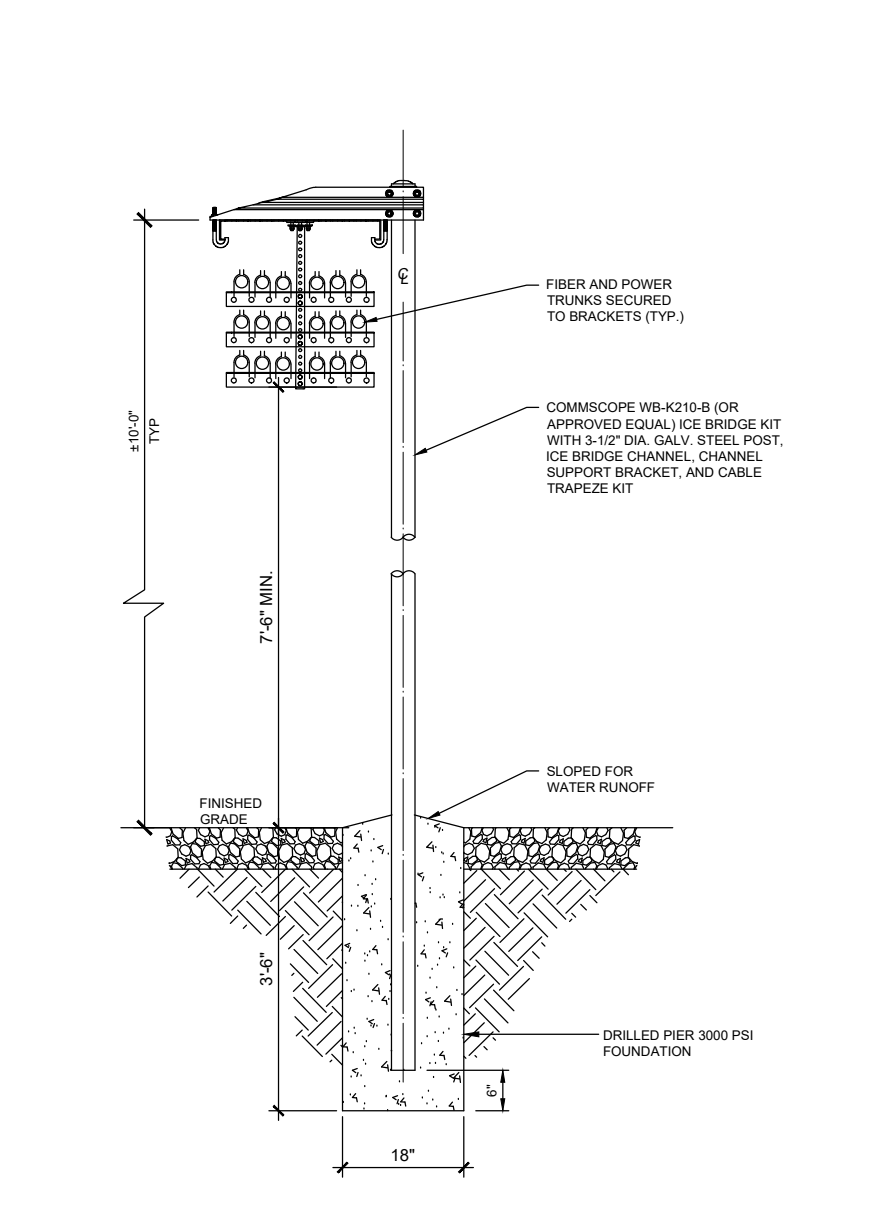

CONCRETE PIER ICE BRIDGE DETAIL

NO SCALE

6

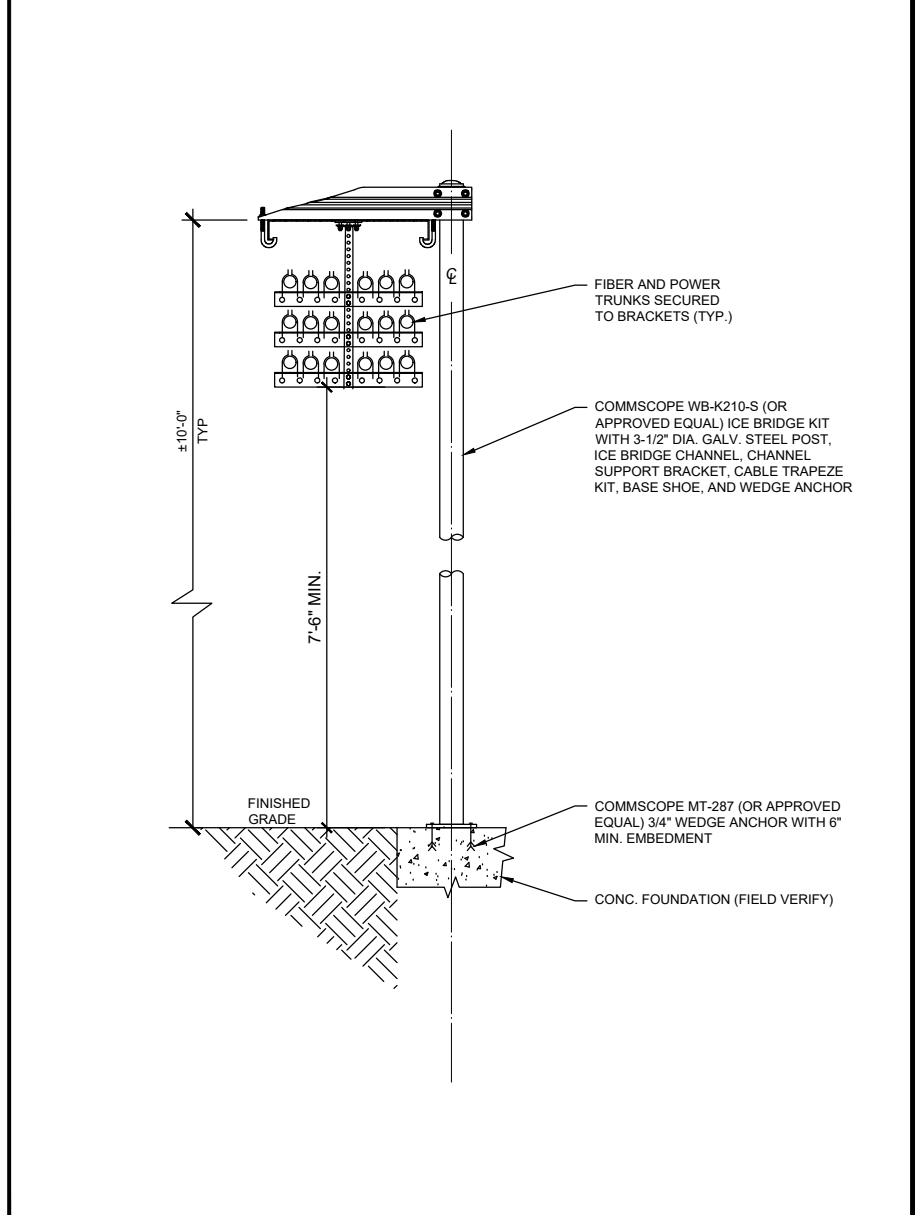

CONCRETE PAD ICE BRIDGE DETAIL

NO SCALE

7

188 INVERNESS DRIVE WEST
SUITE 400
ENGLEWOOD, CO 80112

6615 TOWPATH ROAD
EAST SYRACUSE, NY 13057

520 South Main Street, Suite 2531
Akron, OH 44311
330.572.2100 Fax 330.572.2101
Copyright: Glauz, Pyle, Schomer, Burns & DeHaven, Inc. 2025

GPD JOB #:	2025705.79
DRAWN BY:	ACM
CHECKED BY:	LJB
RFDS:	25309

REV	DATE	DESCRIPTION
0	08/27/2025	FOR CONSTRUCTION
C	08/15/2025	REV. PER COMMENTS
B	08/12/2025	REV. PER COMMENTS
A	06/05/2025	ISSUED FOR REVIEW

IT IS A VIOLATION OF LAW FOR ANY PERSON, UNLESS THEY ARE ACTING UNDER THE DIRECTION OF A LICENSED PROFESSIONAL ENGINEER, TO ALTER THIS DOCUMENT.

SHANNON PARK
SOH3625
6790 COFFMAN RD
DUBLIN, OH 43017
COLOCATION

SHEET TITLE
EQUIPMENT DETAILS

SHEET NUMBER
C-4

NOTICE

Beyond This Point you are entering a controlled area where RF emissions *may exceed* the FCC General Population Exposure Limits.

Follow all posted signs and site guidelines for working in a RF environment.

Ref: 47CFR 1.1307(b)

CAUTION

Beyond This Point you are entering a controlled area where RF emissions *may exceed* the FCC Occupational Exposure Limits.

Obey all posted signs and site guidelines for working in a RF environment.

Ref: 47CFR 1.1307(b)

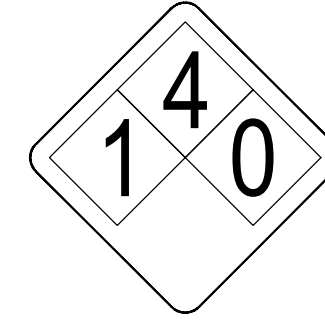
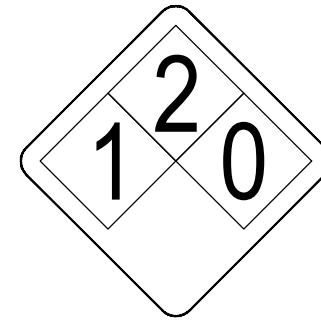
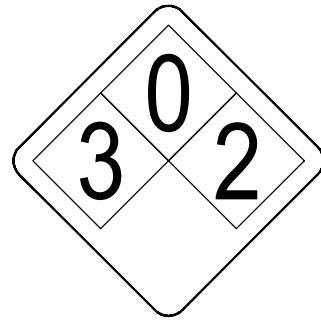

ALERTING SIGN
(FOR CELL SITE BATTERIES)

NO SCALE 6

ALERTING SIGN
(FOR DIESEL FUEL)

NO SCALE 7

ALERTING SIGN
(FOR PROPANE)

NO SCALE 8

188 INVERNESS DRIVE WEST
SUITE 400
ENGLEWOOD, CO 80112

6615 TOWPATH ROAD
EAST SYRACUSE, NY 13057

ALERTING SIGN

NO SCALE 1

WARNING!

DANGER DO NOT TOUCH TOWER!
SERIOUS "RF" BURN HAZARD!

MAINTAIN AN ADEQUATE CLEARANCE BETWEEN TOWER SUPPORTS AND GUY WIRES

FAILURE TO OBEY ALL POSTED SIGNS AND SITE GUIDELINES FOR WORKING IN A RADIO FREQUENCY ENVIRONMENT COULD RESULT IN SERIOUS INJURY. CONTACT CURRENT MAY EXCEED LIMITS PRESCRIBED IN ANSI/IEEE C95.1-1992 FOR CONTROLLED ENVIRONMENTS.

PROPERTY OF AT&T

AUTHORIZED PERSONNEL ONLY

IN CASE OF EMERGENCY, OR PRIOR TO PERFORMING MAINTENANCE ON THIS SITE, CALL 800-638-2622 AND REFERENCE CELL SITE NUMBER

ALERTING SIGN

NO SCALE 2

INFO SIGN #4

NO SCALE 3

INFORMATION

AT&T operates telecommunications antennas at this location. Remain at least 3 feet away from any antenna and obey all posted signs.

Contact the owner(s) of the antenna(s) before working closer than 3 feet from the antenna.

Contact AT&T at _____ prior to performing any maintenance or repairs near AT&T antennas. This is Site# _____

Contact the management office if this door/hatch/gate is found unlocked.

INFORMACION

En esta propiedad se ubican antenas de telecomunicaciones operadas por AT&T. Favor mantener una distancia de no menos de 3 pies y obedecer todos los avisos.

Comuníquese con el propietario o los propietarios de las antenas antes de trabajar o caminar a una distancia de menos de 3 pies de la antena.

Comuníquese con AT&T _____ antes de realizar cualquier mantenimiento o reparaciones cerca de la antena de AT&T.

Esta es la estación base número: _____

Favor comunicarse con la oficina de la administración del edificio si esta puerta o compuerta se encuentra sin candado.

INFORMATION

ACTIVE ANTENNAS ARE MOUNTED

ON THE OUTSIDE OF THIS BUILDING

BEHIND THIS PANEL

ON THIS STRUCTURE

STAY BACK A MINIMUM OF 3 FEET FROM THESE ANTENNAS

Contact AT&T at _____ and follow their instructions prior to performing any maintenance or repairs closer than 3 feet from the antennas.

This is AT&T site# _____

S
T
A
Y
B
A
C
K
3
F
E
E
T
F
R
O
M
A
N
T
E
N
N
A

GENERAL SIGNAGE GUIDELINES

Structure Type	INFO SIGN #1	INFO SIGN #2	INFO SIGN #3	INFO SIGN #4	Striping	NOTICE SIGN	CAUTION SIGN
Towers							
Monopole/Monopine/Monopalm	entrance gates, shelter doors OR on the outdoor cabinets	climbing side of the Tower	On the side of Antennas	entrance gates, shelter doors OR on the outdoor cabinets			At the height of the first climbing step, min. 9ft above ground
SCE Towers/ Towers with high voltage	entrance gates, shelter doors OR on the outdoor cabinets	climbing side of the Tower	On the side of Antennas	entrance gates, shelter doors OR on the outdoor cabinets			At the height of the first climbing step, min. 9ft above ground
Light Poles / Flag Poles	entrance gates, shelter doors OR on the outdoor cabinets	on the pole, no less than 3ft below the Antenna and no less than 9ft above ground	On the side of Antennas	entrance gates, shelter doors OR on the outdoor cabinets			
Utility Wood Poles (JPA)	entrance gates, shelter doors OR on the outdoor cabinets	on the pole, no less than 3ft below the Antenna and no less than 9ft above ground	On the side of Antennas	entrance gates, shelter doors OR on the outdoor cabinets		If GP max value of MPE at antenna level is: 0-99%: Notice sign; over 99%: Caution sign at no less than 3ft below antenna and 9ft above ground	
Microcells mounted on non-JPA poles	entrance gates, shelter doors OR on the outdoor cabinets	on the pole, no less than 3ft below the Antenna and no less than 9ft above ground	On the side of Antennas	entrance gates, shelter doors OR on the outdoor cabinets		Notice or Caution sign at no less than 9ft above ground; only if the exposure exceeds 90% of the General Public exposure at 6ft above ground or at outside surface of adjacent buildings	
Roof Tops							
At all access points to the roof	X			X			
On Antennas	X		X	X			
Concealed Antennas	X	X		X			
antennas mounted facing outside the building	X	X		X			
antennas on support structure	X	X		X			
Roofview Graph:							
Radiation area is within 3ft from antenna	X	adjacent to each antenna		X			
Radiation area is beyond 3ft from antenna	X	adjacent to each antenna		X	diagonal, yellow striping as to Roofview graph		either Notice or Caution sign (based on Roofview results) at antennas/barrier
Church Steeples	Access to steeple	adjacent to antennas if antennas are concealed	On the side of Antennas	Access to steeple			Caution sign at the antennas
Water Stations	Access to ladder	adjacent to antennas if antennas are concealed	On the side of Antennas	Access to ladder			Caution sign beside Info sign #1, min. 9ft above ground

Notes for Rooftop sites:

1. Either NOTICE or CAUTION signs need to be posted at each sector as close as possible to: the outer edge of the striped off area or the outer antennas of the sector.
2. If Roofview shows: only blue = Notice Sign, blue and yellow = Caution Sign, only yellow = Caution Sign to be installed.
3. Should the required striping area interfere with any structures or equipment (A/C, vents, roof hatch, doors, other antennas, dishes, etc.), please notify AT&T to modify the striping area, prior to starting the work

INFO SIGN #1

NO SCALE 4

INFO SIGN #2

NO SCALE 5

INFO SIGN #3

NO SCALE 9

SIGNAGE GUIDELINES CHART

10

GPD JOB #: 2025705.79

DRAWN BY: ACM

CHECKED BY: LJB

RFDS: 25309

REV	DATE	DESCRIPTION
0	08/27/2025	FOR CONSTRUCTION
C	08/15/2025	REV. PER COMMENTS
B	08/12/2025	REV. PER COMMENTS
A	06/05/2025	ISSUED FOR REVIEW

REFERENCE ONLY

IT IS A VIOLATION OF LAW FOR ANY PERSON, UNLESS THEY ARE ACTING UNDER THE DIRECTION OF A LICENSED PROFESSIONAL ENGINEER, TO ALTER THIS DOCUMENT.

SHANNON PARK
SOH3625
6790 COFFMAN RD
DUBLIN, OH 43017
COLOCATION

SHEET TITLE
SIGNAGE DETAILS

SHEET NUMBER

C-5

PART 1 - GENERAL

- 1.1 SCOPE:
- A. FORM WORK, REINFORCING STEEL, ACCESSORIES, CAST-IN PLACE CONCRETE, FINISHING, CURING AND TESTING FOR STRUCTURAL CONCRETE FOUNDATIONS.
- 1.2 REFERENCES:
- A. ACI (AMERICAN CONCRETE INSTITUTE)
- ACI 301 SPECIFICATION FOR STRUCTURAL CONCRETE FOR BUILDINGS.
 - ACI 304 RECOMMENDED PRACTICE FOR MEASURING, MIXING, TRANSPORTING AND PLACING CONCRETE.
 - ACI 305 RECOMMENDED PRACTICE FOR HOT WEATHER CONCRETING.
 - ACI 306 RECOMMENDED PRACTICE FOR COLD WEATHER CONCRETING.
 - ACI 308 STANDARD PRACTICE FOR CURING CONCRETING.
 - ACI 309 STANDARD PRACTICE FOR CONSOLIDATION OF CONCRETE.
 - ACI 318 BUILDING CODE REQUIREMENTS FOR REINFORCED CONCRETE.
 - ACI 347 RECOMMENDED PRACTICE FOR CONCRETE FORMWORK DRILL PIERS.
- B. ASTM (AMERICAN SOCIETY FOR TESTING AND MATERIALS). THE APPLICABLE STANDARDS OF THE AMERICAN SOCIETY FOR TESTING AND MATERIALS ARE LISTED IN THE ACI STANDARDS AND ARE A PART OF THIS SPECIFICATION.

PART 2 - PRODUCTS

- 2.1 REINFORCING MATERIALS:
- A. REINFORCING BARS: ASTM A615, GRADE 60, PROPOSED DEFORMED BILLET-STEEL BARS, PLAIN FINISH.
- B. FURNISH CHAIRS, BOLSTERS, BAR SUPPORTS, SPACERS AS REQUIRED FOR SUPPORT OF REINFORCING STEEL AND WIRE FABRIC.
- 2.2 CONCRETE MATERIALS:
- A. PORTLAND CEMENT SHALL BE TYPE II, CONFORMING TO ASTM C-150.
- B. AGGREGATE SHALL CONFORM TO ASTM C-33.
- FINE AGGREGATE SHALL BE UNIFORMLY GRADED, CLEAN SHARP, WASHED NATURAL, OR CRUSHED SAND, FREE FROM ORGANIC IMPURITIES.
 - COARSE AGGREGATE SHALL BE NATURAL WASHED GRAVEL OR WASHED CRUSHED ROCK HAVING HARD, STRONG, DURABLE PIECES, FREE FROM ADHERENT COATINGS.
 - MAXIMUM SIZE OF COARSE AGGREGATE SHALL BE 3/4 INCH IN ACCORDANCE WITH THE REQUIREMENTS OF ASTM C-33 GRADATION SIZE NO. 67.
- C. WATER USED IN CONCRETE MIX SHALL BE POTABLE, CLEAN, AND FREE FROM OILS, ACIDS, SALTS, CHLORIDES, ALKALI, SUGAR, VEGETABLE, OR OTHER INJURIOUS SUBSTANCES.
- D. THE CONCRETE SHALL CONTAIN AN AIR-ENTRAINING ADMIXTURE COMPLYING WITH THE REQUIREMENTS OF ASTM C-260 AND ACI 212. 1R AND A WATER- REDUCING ADMIXTURE COMPLYING WITH THE REQUIREMENTS OF ASTM C-494 AND ACI 212. 1R. ADMIXTURES SHALL BE PURCHASED AND BATCHED IN LIQUID SOLUTION. THE USE OF CALCIUM CHLORIDE OR AN ADMIXTURE CONTAINING CALCIUM CHLORIDE IS PROHIBITED. ADMIXTURES SHALL BE OF THE SAME MANUFACTURER TO ASSURE COMPATIBILITY. ACCEPTABLE MANUFACTURERS ARE:
- W.R. GRACE
 - SIKA CORP.
 - MASTER BUILDERS
 - EUCLID CHEMICAL CO.
 - APPROVED EQUAL
- E. CURING COMPOUND SHALL CONFORM TO ASTM C309, TYPE I, ID, CLASS A AND B AND ASTM C171 AS APPLICABLE.
- 2.3 CONCRETE MIX:
- A. PROPORTION CONCRETE MIX IN ACCORDANCE WITH REQUIREMENTS OF ACI 301. THE STRENGTH OF CONCRETE SHALL BE AS INDICATED ON THE DRAWINGS. WHERE STRENGTH IS NOT CLEARLY INDICATED, CONCRETE SHALL HAVE A MINIMUM 28 DAY COMPRESSIVE STRENGTH OF 4000 PSI.
- B. THE CONCRETE MIX SHALL BE DESIGNED FOR A MAXIMUM SLUMP OF THREE INCHES (PLUS OR MINUS 1-INCH) AT THE POINT OF DISCHARGE. MIXES OF THE STIFFEST CONSISTENCY THAT CAN BE EFFICIENTLY PLACED SHALL BE USED.
- C. ALL CONCRETE SHALL BE TO SIX PERCENT (6%) AIR ENTRAINED (PLUS OR MINUS 1%).
- D. ALL STRUCTURAL CONCRETE SHALL CONTAIN A WATER-REDUCING AGENT.

PART 3 - EXECUTION

- 3.1 GENERAL:
- CONSTRUCT AND ERECT THE FORM WORK IN ACCORDANCE WITH ACI 301 AND ACI 347.
 - COLD-WEATHER CONCRETING SHALL BE IN ACCORDANCE WITH ACI 306.
 - HOT-WEATHER CONCRETING SHALL BE IN ACCORDANCE WITH ACI 305.
- 3.2 INSERTS, EMBEDDED COMPONENTS AND OPENINGS:
- A. CONTRACTOR SHALL CHECK ALL CIVIL, ARCHITECTURAL, STRUCTURAL AND ELECTRICAL DRAWINGS FOR OPENINGS, SLEEVES, ANCHOR BOLTS, INSERTS AND OTHER ITEMS TO BE BUILT INTO THE CONCRETE WORK.
- B. COORDINATE THE WORK OF OTHER SECTION IN FORMING AND SETTING OPENINGS, RECESSES, SLOTS, CHASES, ANCHORS, INSERTS AND OTHER ITEMS TO BE EMBEDDED.
- C. EMBEDDED ITEMS SHALL BE SET ACCURATELY IN LOCATION, ALIGNMENT, ELEVATION AND PLUMBNESS, LOCATE AND MEASURE FROM ESTABLISHED SURVEYED REFERENCE BENCHMARKS.
- D. EMBEDDED ITEMS SHALL BE ANCHORED INTO PLACE IN A MANNER TO PREVENT MOVEMENT DURING CONCRETE PLACEMENT AND CONSOLIDATION. COMPONENTS FORMING A PART OF A COMPLETE

ASSEMBLY SHALL BE ALIGNED BEFORE ANCHORING INTO PLACE. PROVIDE TEMPORARY BRACING, ANCHORAGE, AND TEMPLATES AS REQUIRED TO MAINTAIN THE SETTING AND ALIGNMENT.

- 3.3 REINFORCEMENT PLACEMENT:
- A. PLACE REINFORCEMENT ACCORDING TO CHECKED AND RELEASED DRAWINGS AND IN ACCORDANCE WITH ACI 301 AND ACI 318.
- B. ACCURATELY POSITION, SUPPORT AND SECURE REINFORCEMENT AGAINST DISPLACEMENT FROM FORM WORK CONSTRUCTION OR CONCRETE PLACEMENT AND CONSOLIDATION. SUPPORT REINFORCING ON METAL CHAIRS, RUNNERS, BOLSTERS, SPACERS AND HANGERS.
- C. SPLICES OF REINFORCING BARS SHALL BE CLASS B UNLESS SHOWN OTHERWISE ON THE DRAWINGS. SPLICES SHALL BE STAGGERED. FULL DEVELOPMENT LENGTH SHALL BE PROVIDED ACROSS JOINTS.
- D. LOCATE REINFORCING TO PROVIDE CONCRETE COVER AND SPACING SHOWN ON THE DRAWINGS. MINIMUM COVER SHALL BE AS REQUIRED BY ACI 318.
- E. WELDING OF AND TO ANY REINFORCING MATERIALS INCLUDING TACK WELDING OF CROSSING BARS IS STRICTLY PROHIBITED.
- 3.4 CONCRETE PLACEMENT:
- A. PRIOR TO PLACING CONCRETE, THE FORMS AND REINFORCEMENT SHALL BE THOROUGHLY INSPECTED; ALL TEMPORARY BRACING, TIES AND CLEATS REMOVED; ALL OPENINGS FOR UTILITIES PROPERLY BOXED; ALL FORMS PROPERLY SECURED IN THEIR CORRECT POSITION AND MADE TIGHT. ALL REINFORCEMENT AND EMBEDDED ITEMS SHALL BE SECURED IN THEIR PROPER LOCATIONS. ALL OLD AND DRY CONCRETE AND DIRT SHALL BE CLEANED OFF AND ALL STANDING WATER AND OTHER FOREIGN MATERIAL REMOVED.
- B. PLACING CONCRETE SHALL BE IN ACCORDANCE WITH ACI 301 AND ACI 304 AND SHALL BE CARRIED OUT AT SUCH A RATE THAT THE CONCRETE PREVIOUSLY PLACED IS STILL PLASTIC AND INTEGRATED WITH THE FRESHLY PLACED CONCRETE. CONCRETING ONCE STARTED, SHALL BE CARRIED ON AS A CONTINUOUS OPERATION UNTIL THE SECTION IS COMPLETED. NO COLD JOINTS SHALL BE ALLOWED.
- C. ALL CONCRETE SHALL BE THOROUGHLY CONSOLIDATED AND COMPACTED BY VIBRATION SPACING, RODDING, OR FORKING DURING THE OPERATION OF PLACING AND DEPOSITING IN ACCORDANCE WITH ACI 309. THE CONCRETE SHALL BE THOROUGHLY WORKED AROUND REINFORCEMENT, EMBEDDED ITEMS, AND INTO THE CORNER OF THE FORMS SO AS TO ELIMINATE ALL AIR AND STONE POCKETS.
- 3.5 FINISHING:
- A. FINISHING OF THE FLOOR SLABS SHALL BE IN ACCORDANCE WITH ACI 302.1 SECTION 7.2 WITH A MINIMUM OF THREE TROWELINGS. THE SLAB FINISH TOLERANCE AS MEASURED IN ACCORDANCE WITH ASTM E 1155 SHALL HAVE AN OVERALL TEST NUMBER FOR FLATNESS, FF= 20 AND FOR LEVEL. FL=15. THE MINIMUM LOCAL NUMBER FOR FLATNESS, FF= 15 AND FOR LEVEL FL=10.
- B. SURFACE OF FLOOR SLAB SHALL RECEIVE TWO COATS OF CLEAR SEALER/HARDENER.
- C. ABOVE GRADE WALL SURFACES SHALL HAVE A SMOOTH FORM FINISH AS DEFINED IN CHAPTER 10 OF ACI 301.
- 3.6 CURING:
- A. FRESHLY DEPOSITED CONCRETE SHALL BE PROTECTED FROM PREMATURE DRYING AND EXCESSIVELY HOT AND COLD TEMPERATURES AND SHALL BE MAINTAINED WITH MINIMUM MOISTURE LOSS AT A RELATIVELY CONSTANT TEMPERATURE FOR A PERIOD OF TIME NECESSARY FOR THE HYDRATION OF THE CEMENT AND PROPER HARDENING OF THE CONCRETE.
- B. CONCRETE SHALL BE KEPT CONTINUOUSLY MOIST AT LEAST OVERNIGHT, IMMEDIATELY FOLLOWING THE INITIAL CURING. BEFORE THE CONCRETE HAS DRIED, ADDITIONAL CURING SHALL BE ACCOMPLISHED BY ONE OF THE FOLLOWING MATERIALS OR METHODS:
- PONDING OR CONTINUOUS SPRINKLING.
 - ABSORPTIVE MAT OR FABRIC KEPT CONTINUOUSLY WET.
 - NON-ABSORPTIVE FILM (POLYETHYLENE) OVER PREVIOUSLY SPRINKLED SURFACE.
 - SAND OR OTHER COVERING KEPT CONTINUOUSLY WET.
 - CONTINUOUS STEAM (NOT EXCEEDING 150 F) OR VAPOR MIST BATH.
 - SPRAYED-ON CURING COMPOUND APPLIED IN TWO COATS, SPRAYED IN PERPENDICULAR DIRECTION.
- C. THE FINAL CURING SHALL CONTINUE UNTIL THE CUMULATIVE NUMBER OF DAYS OR FRACTION THEREOF, NOT NECESSARILY CONSECUTIVE, DURING WHICH TEMPERATURE OF THE AIR IN CONTACT WITH CONCRETE IS ABOVE 50F HAS TOTALED SEVEN (7) DAYS. CONCRETE SHALL NOT BE PERMITTED TO FREEZE DURING THE CURING PERIOD. RAPID DRYING AT THE END OF THE CURING PERIOD SHALL BE PREVENTED.

- ALL FABRICATION AND INSTALLATION SHOULD BE DONE BY A CONTRACTOR EXPERIENCED IN SIMILAR WORK.
- CONTRACTOR SHOULD OBSERVE ALL OSHA AND OTHER APPLICABLE SAFETY GUIDELINES DURING INSTALLATION.
- ALL FABRICATION AND INSTALLATION PROCEDURES AND SITE SAFETY ARE THE SOLE RESPONSIBILITY OF THE CONTRACTOR.
- CONTRACTOR SHOULD FIELD VERIFY ALL DIMENSIONS AND FIT BEFORE FABRICATION.
- THE DRAWINGS DO NOT INCLUDE ALL THE EXISTING FIELD CONDITIONS, SOME OF WHICH MAY INTERFERE WITH THE INSTALLATION. CONTRACTOR SHOULD CONDUCT A FIELD SURVEY TO IDENTIFY ANY POTENTIAL DIFFICULTIES IN THE INSTALLATION BEFORE WORK COMMENCES. CONTACT THE ENGINEER IF THE FIELD CONDITIONS REQUIRE ANY CHANGES IN THE DESIGN.
- CONTRACTOR MAY HAVE TO TEMPORARILY REMOVE EXISTING TRANSMISSION LINES AND OTHER OBSTRUCTIONS TO INSTALL NEW STRUCTURE. COORDINATE ALL SUCH PROCEDURES WITH THE BUILDING OWNER.
- CONTRACTOR IS RESPONSIBLE FOR OBTAINING ALL LICENSES, PERMITS AND ANY OTHER APPROVALS REQUIRED FOR CONSTRUCTION.
- PAINT THE NEW MEMBERS TO MATCH THE EXISTING STRUCTURE.
- THE STRUCTURAL STEEL CONTRACTOR SHALL BE RESPONSIBLE FOR VERIFYING THE ANCHOR BOLT LOCATIONS, ELEVATIONS OF TOP CONCRETE AND BEARING PLATES, ALIGNMENT ETC. PRIOR TO START OF STEEL ERECTION.
- THE LATEST EDITION OF THE FOLLOWING SPECIFICATIONS SHALL GOVERN:
 - AISC - "ALLOWABLE STRESS DESIGN SPECIFICATION FOR STRUCTURAL STEEL BUILDINGS"
 - AISC - "CODE OF STANDARD PRACTICE FOR STEEL BUILDINGS AND BRIDGES"
 - AWS - "D1.1 STRUCTURAL WELDING CODE - STEEL"
- MATERIAL, UNLESS OTHERWISE NOTED, SHALL CONFORM TO THE FOLLOWING ASTM SPECIFICATIONS
 - STRUCTURAL WIDE FLANGE & M SHAPES

A992 OR A572	Fy = 50 KSI
A36, Fy = 36KSI	A500, GRADE B
Fy = 46 KSI	A325
A36	A307 OR A36
SCH 40 PIPE	
 - OTHER STRUCTURAL SHAPES AND PLATES
 - STRUCTURAL TUBING
 - HIGH STRENGTH BOLTS
 - THREADED RODS
 - ANCHOR BOLTS
 - PIPE (HANDRAIL)
- ALL STEEL SHALL BE HOT DIPPED GALVANIZED AS PER ASTM A123 SPECIFICATIONS.
- ALL STEEL HARDWARE SHALL BE HOT DIPPED GALVANIZED PER ASTM A153.
- ALL BOLTS SHALL BE DOMESTIC, NEW 1/2 INCH DIAMETER HIGH STRENGTH GALVANIZED BOLTS, BEARING TYPE 'X', UNLESS NOTED OTHERWISE IN THE DRAWINGS AND SHALL CONFORM TO ASTM A325 SPECIFICATIONS. USE ANCO LOCKNUTS & FLAT WASHERS ON ALL BOLTS.
- ALL FINISHED BOLT HOLES SHALL NOT BE MORE THAN 1/16 INCH LARGER THAN THE BOLT DIAMETER UNLESS NOTED OTHERWISE.
- ALL BOLTS SHALL BE TIGHTENED USING TURN-OF-THE-NUT METHOD.
- ALL BOLT HOLES EDGE DISTANCES SHALL BE 1 1/2 INCH UNLESS OTHERWISE NOTED.
- ALL WELDING SHALL BE DONE USING E-70 ELECTRODES AND IN ACCORDANCE WITH THE AMERICAN WELDING SOCIETY STANDARDS AND SPECIFICATIONS.
- ANY FIELD CUTS MUST BE THOROUGHLY CLEANED AND DOUBLE COATED.
- DO NOT HEAT STRUCTURAL MATERIAL FOR STRAIGHTENING BENT OR WARPED MEMBERS.
- CLEAN THE SITE OF ALL DEBRIS UPON COMPLETION OF THE WORK. STORE ALL SURPLUS MATERIALS NEATLY IN AN AREA APPROVED BY THE OWNER.
- BEFORE FIELD WELDING CLEAN ALL PAINT AND GALVANIZING TO BARE METAL. PREHEATING AND POSTHEATING OF THE BASE METAL SHOULD BE AS PER AWS D1.1 SPECIFICATION AND APPLICABLE CODES REGARDING PREHEATING AND POSTHEATING.
- CONTRACTOR TO PROVIDE FIRE PROTECTION BEFORE FIELD WELDING.
- HOLES IN STEEL SHALL BE DRILLED OR PUNCHED. ALL SLOTTED HOLES SHALL BE PROVIDED WITH SMOOTH EDGES. BURNING OF HOLES AND TORCH CUTTING AT THE SITE IS NOT PERMITTED. ALL HOLES IN BEARING PLATES SHALL BE DRILLED.
- EPOXY ANCHORS TO BE INSTALLED PER MANUFACTURER'S SPECIFICATIONS.



GPD JOB #:	2025705.79
DRAWN BY:	ACM
CHECKED BY:	LJB
RFDS:	25309

REV	DATE	DESCRIPTION
0	08/27/2025	FOR CONSTRUCTION
C	08/15/2025	REV. PER COMMENTS
B	08/12/2025	REV. PER COMMENTS
A	06/05/2025	ISSUED FOR REVIEW

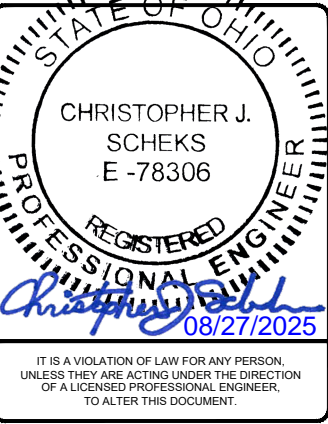

SHANNON PARK
SOH3625
6790 COFFMAN RD
DUBLIN, OH 43017
COLOCATION

SHEET TITLE
CONCRETE WORK AND
STRUCTURAL NOTES

SHEET NUMBER
C-6

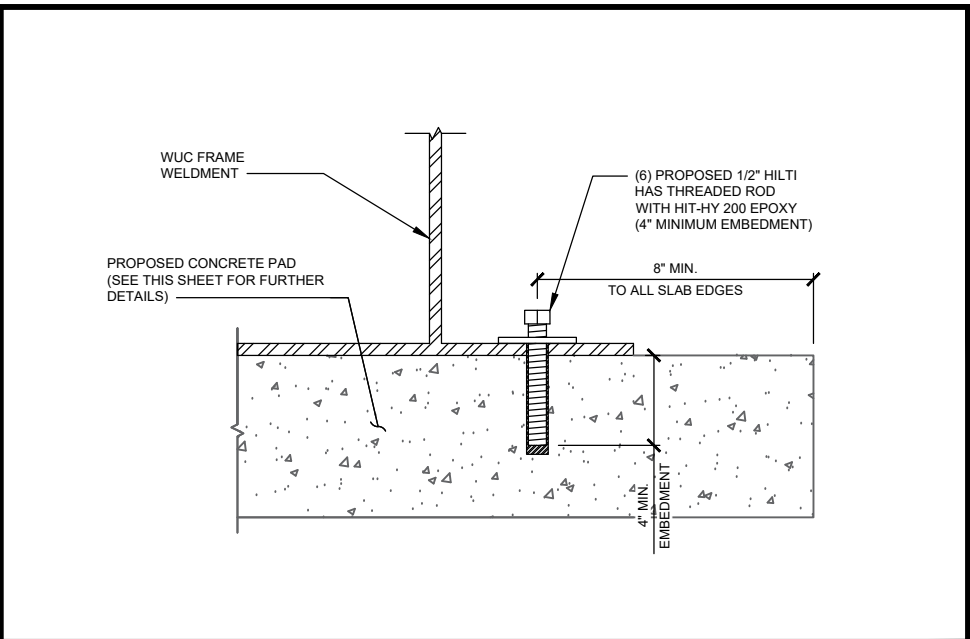
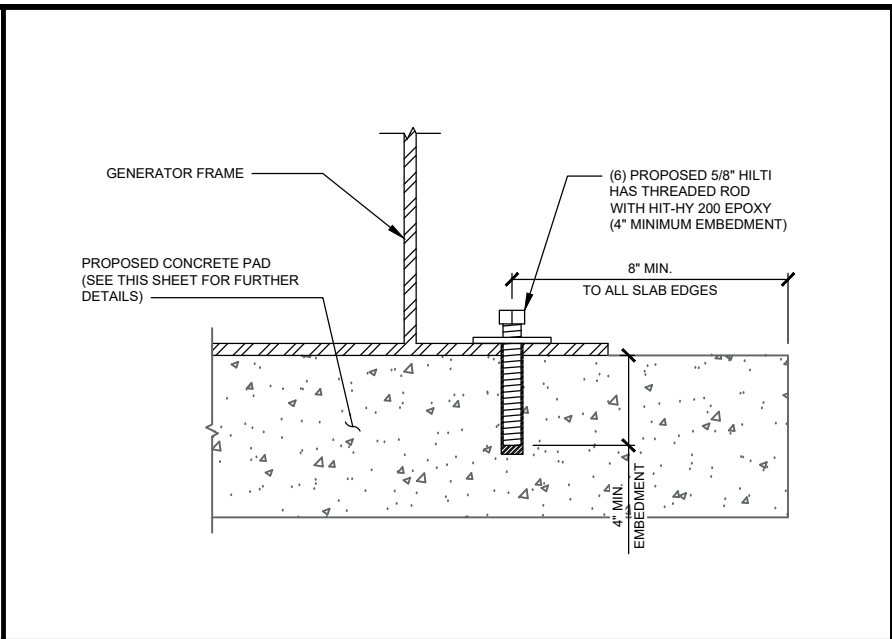

DETAIL NOT USED NO SCALE 2

GENERATOR FRAME CONCRETE ANCHOR DETAIL NO SCALE 4

WUC FOUNDATION CONCRETE ANCHOR DETAIL NO SCALE 7

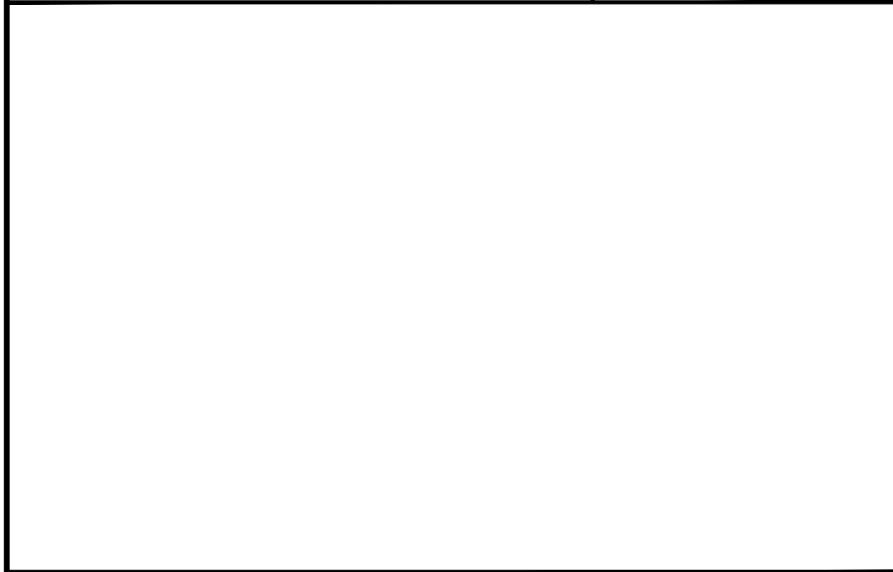

FOUNDATION NOTES

- HILTI PRODUCTS MUST BE INSTALLED IN ACCORDANCE WITH MANUFACTURERS PRINTED INSTALLATION INSTRUCTIONS AS INCLUDED IN THE ADHESIVE PACKAGING.
- CONTRACTOR SHALL AVOID DRILLING HOLES IN VERTICAL/HORIZONTAL REINFORCING BARS.
- HOLES MUST BE WIRE BRUSHED AND BLASTED WITH COMPRESSED AIR PRIOR TO INSTALLATION. TEMPERATURES, METHODS, WORKING TIME, ETC. ARE TO BE IN ACCORDANCE WITH MANUFACTURER SPECIFICATIONS.

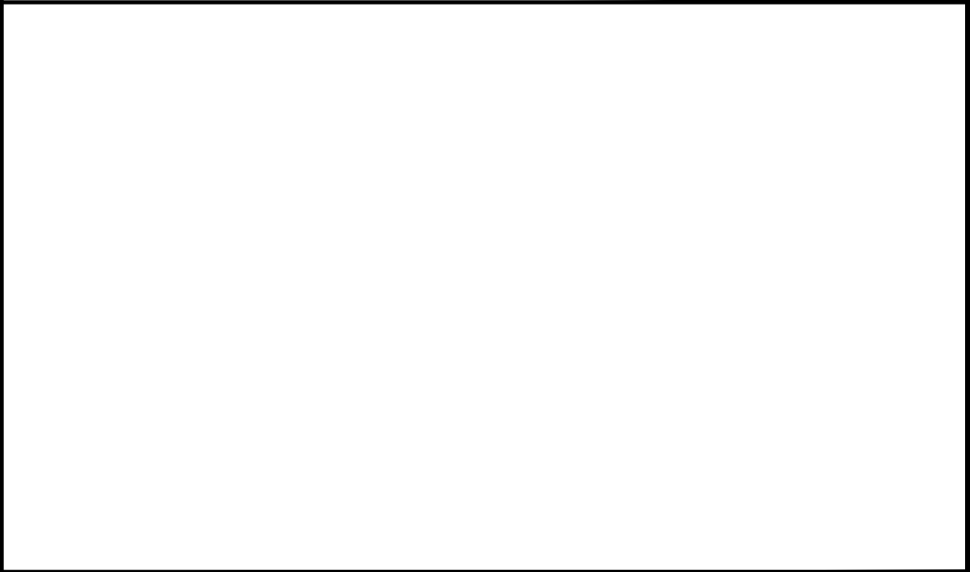

DETAIL NOT USED NO SCALE 2

FOUNDATION NOTES 5

DETAIL NOT USED NO SCALE 8

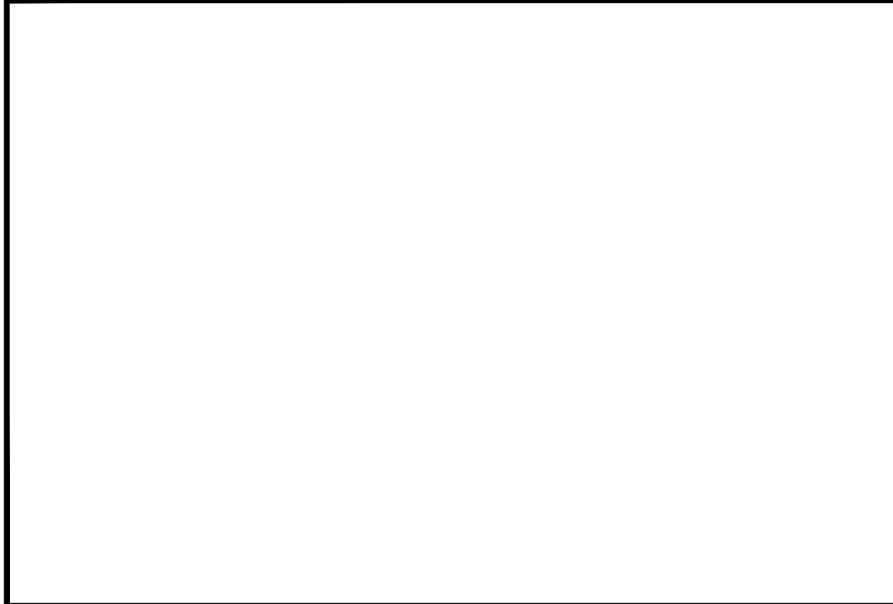

MECHANICAL ANCHOR NOTES

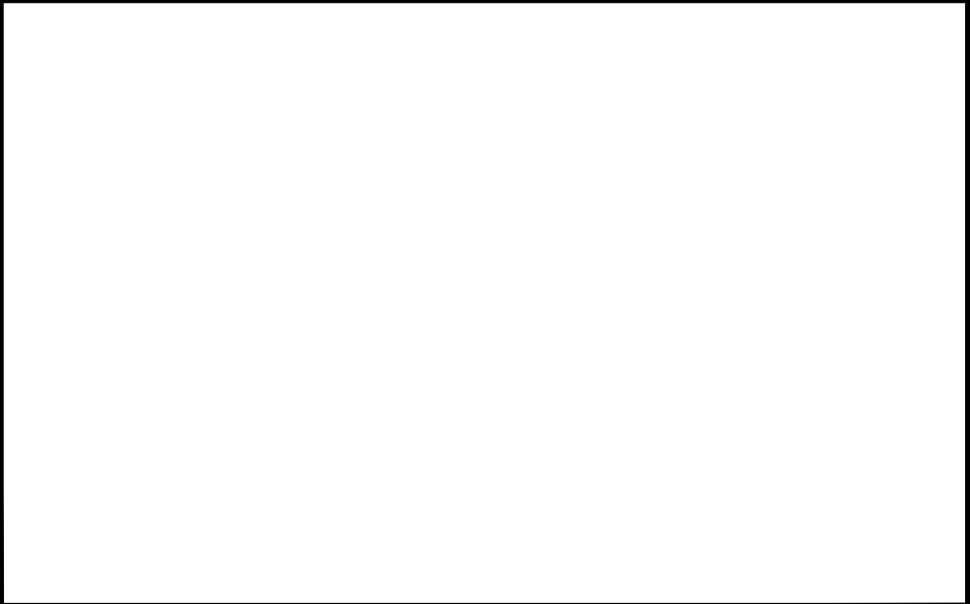

DETAIL NOT USED NO SCALE 3

MECHANICAL ANCHOR NOTES NO SCALE 6

DETAIL NOT USED NO SCALE 9

188 INVERNESS DRIVE WEST
SUITE 400
ENGLEWOOD, CO 80112

6615 TOWPATH ROAD
EAST SYRACUSE, NY 13057

520 South Main Street, Suite 2531
Akron, OH 44311
330.572.2100 Fax 330.572.2101
Copyright: Glauz, Pyle, Schomer, Burns & DeHaven, Inc. 2025

GPD JOB #:	2025705.79
DRAWN BY:	ACM
CHECKED BY:	LJB
RFDS:	25309

REV	DATE	DESCRIPTION
0	08/27/2025	FOR CONSTRUCTION
C	08/15/2025	REV. PER COMMENTS
B	08/12/2025	REV. PER COMMENTS
A	06/05/2025	ISSUED FOR REVIEW

IT IS A VIOLATION OF LAW FOR ANY PERSON, UNLESS THEY ARE ACTING UNDER THE DIRECTION OF A LICENSED PROFESSIONAL ENGINEER, TO ALTER THIS DOCUMENT.

SHANNON PARK
SOH3625
6790 COFFMAN RD
DUBLIN, OH 43017
COLOCATION

SHEET TITLE
CONCRETE PAD DETAILS
AND FOUNDATION NOTES

SHEET NUMBER
C-7

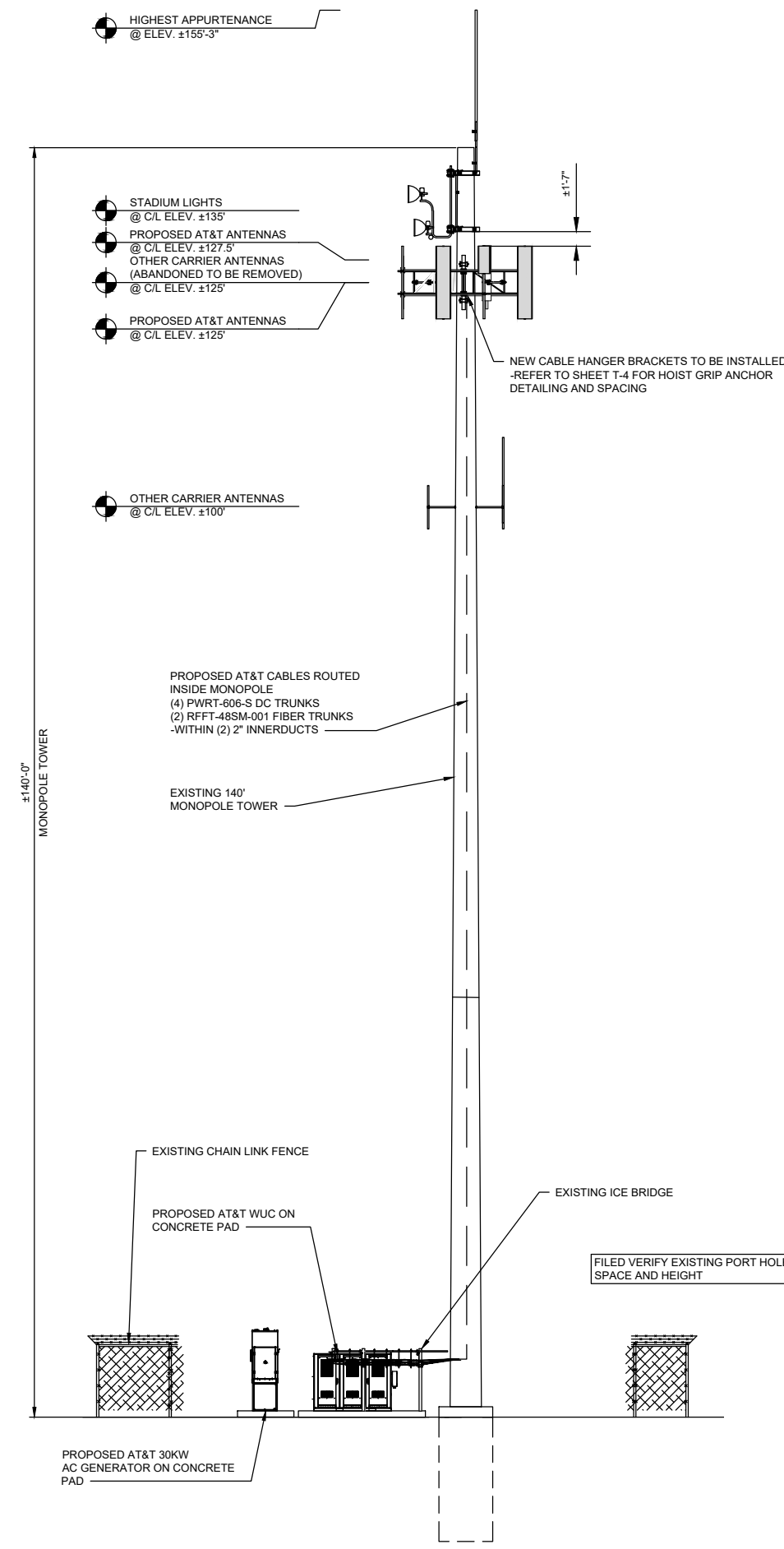

TOWER ELEVATION

NO SCALE

1

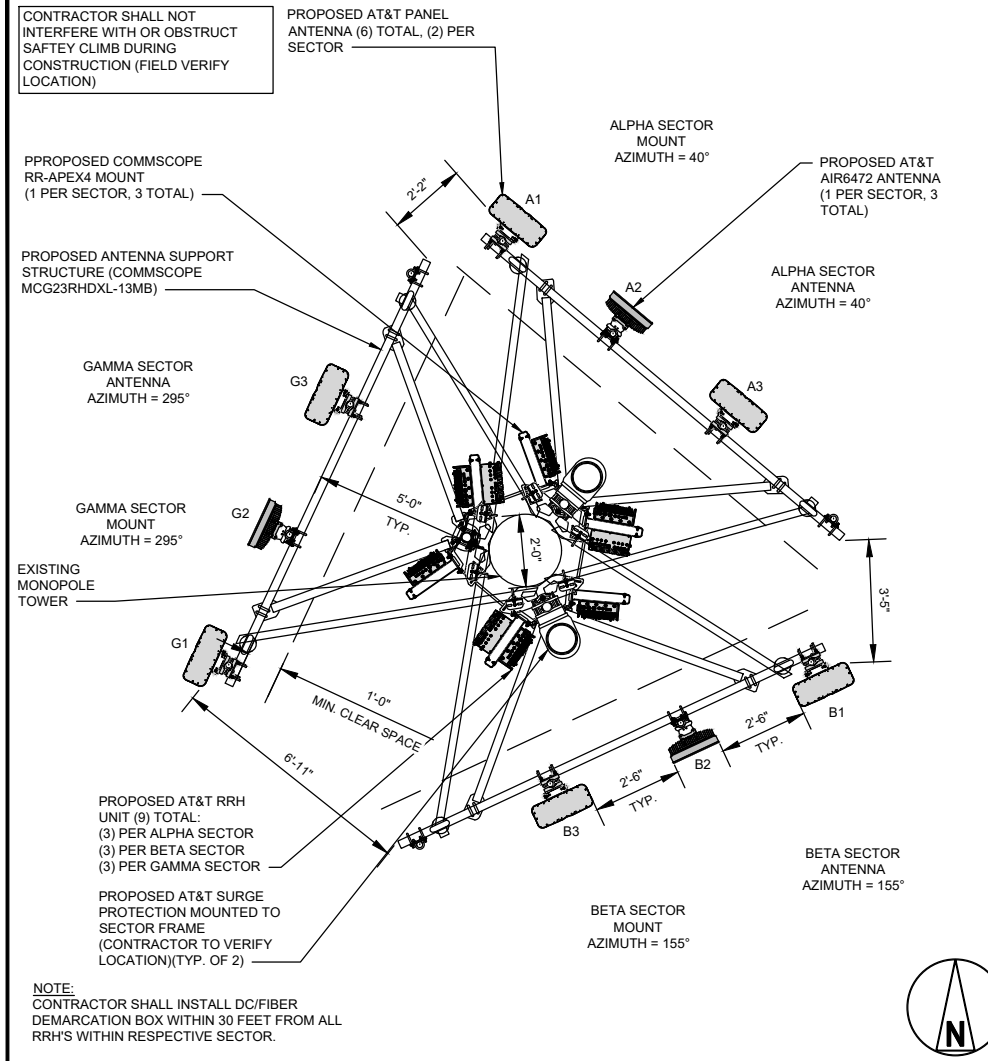

ANTENNA LAYOUT PLAN

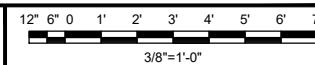

2

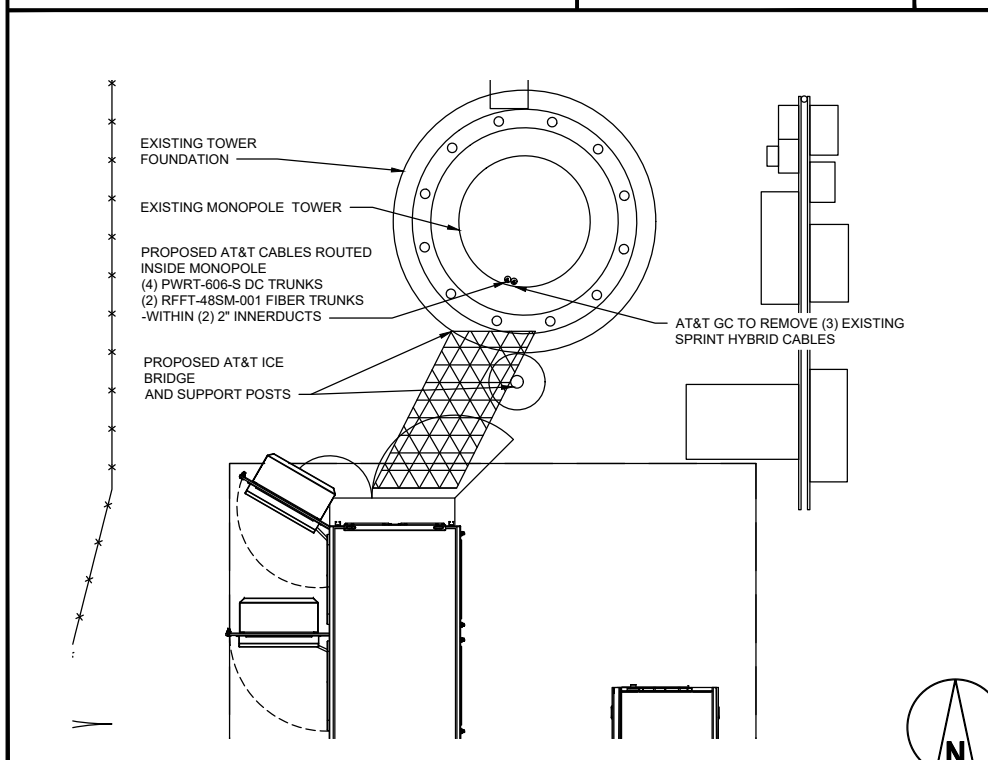

CABLE/FIBER ROUTING PLAN

NO SCALE

3

1. RFDS TO BE VERIFIED WITH AT&T FOR FINAL VERSION PRIOR TO CONSTRUCTION.
2. CONTRACTOR TO ENSURE ANY RFDS ALTERATIONS ARE COVERED WITHIN THE STRUCTURAL ANALYSIS AND TOWER AND FOUNDATION DESIGN.
3. CONTRACTOR TO NOTIFY GPD GROUP IF ANTENNAS MOUNT TIEBACKS TO BE INSTALLED PER CD OR PER MANUFACTURER RECOMMENDATIONS

GENERAL NOTES

4

1. TYPES AND SIZES OF THE ANTENNA CABLE ARE BASED ON ESTIMATED LENGTHS. PRIOR TO ORDERING CABLE, CONTRACTOR SHALL VERIFY ACTUAL LENGTH BASED ON CONSTRUCTION LAYOUT AND NOTIFY THE PROJECT MANAGER IF ACTUAL LENGTHS EXCEED ESTIMATED LENGTHS.
2. CONTRACTOR SHALL VERIFY THE DOWN-TILT OF EACH ANTENNA WITH A DIGITAL LEVEL.
3. CONTRACTOR TO CONFIRM COAX COLOR CODING PRIOR TO CONSTRUCTION. REFER TO "ANTENNA SYSTEM LABELING STANDARD" ND-00027, REFER TO THE LATEST VERSION.
4. ALL JUMPERS TO THE ANTENNAS FROM THE MAIN TRANSMISSION LINE WILL BE 1/2" DIA. LDF AND SHALL NOT EXCEED 6'-0".
5. ALL COAXIAL CABLE WILL BE SECURED TO THE DESIGNED SUPPORT STRUCTURE, IN AN APPROVED MANNER, AT DISTANCES NOT TO EXCEED 4'-0" OC.
6. CONTRACTOR MUST FOLLOW ALL MANUFACTURER'S RECOMMENDATIONS REGARDING BOTH THE INSTALLATION AND GROUNDING OF ALL COAXIAL CABLES, CONNECTORS, ANTENNAS, AND ALL OTHER EQUIPMENT.
7. WEATHERPROOF ALL ANTENNA CONNECTORS WITH SELF AMALGAMATING TAPE. WEATHERPROOFING SHALL BE COMPLETED IN STRICT ACCORDANCE WITH AT&T STANDARDS.
8. CONTRACTOR SHALL GROUND ALL EQUIPMENT, INCLUDING ANTENNAS, RET MOTORS, TMA'S, COAX CABLES, AND RET CONTROL CABLES AS A COMPLETE SYSTEM. GROUNDING SHALL BE EXECUTED BY QUALIFIED WIREMEN IN COMPLIANCE WITH MANUFACTURER'S SPECIFICATION AND RECOMMENDATION.
9. CONTRACTOR SHALL PROVIDE STRAIN-RELIEF AND CABLE SUPPORTS FOR ALL CABLE ASSEMBLIES, COAX CABLES, AND RET CONTROL CABLES. CABLE STRAIN-RELIEFS AND CABLE SUPPORTS SHALL BE APPROVED FOR THE PURPOSE. INSTALLATION SHALL BE IN ACCORDANCE WITH MANUFACTURER'S SPECIFICATIONS AND RECOMMENDATIONS.
10. CONTRACTOR TO VERIFY THAT EXISTING COAX HANGERS ARE STACKABLE SNAP IN HANGERS. IF EXISTING HANGERS ARE NOT STACKABLE SNAP IN HANGERS THE CONTRACTOR SHALL REPLACE EXISTING HANGERS WITH NEW SNAP IN HANGERS IF APPLICABLE.

ANTENNA CABLE NOTES

5

PROPOSED EQUIPMENT:		
QTY	PART #	ITEM
3	COMMSCOPE NNHH-65B-R4	ANTENNAS
3	COMMSCOPE NNH4-65C-R6-V3	ANTENNAS
3	ERICSSON AIR 6472 B77G B77M	ANTENNAS
3	ERICSSON 4490 B5/B12A	RRHS
3	ERICSSON 4494 B14/B29	RRHS
3	ERICSSON 4890 B25/B66	RRHS
2	RAYCAP DC9-48-60-24-8C-EV	DC/FIBER DEMARCATION BOX
3	COMMSCOPE SECTOR FRAME SERIES (MCG23RHDXL-13MB)	SECTOR FRAMES
12	2-7/8" x126" MOUNT PIPES	ANTENNA PIPES
24	SITEPRO1 SCX-U (OR APPROVED EQUAL)	ANTENNA PIPE CROSSOVER
3	COMMSCOPE RR-APEX4 MOUNT	RRH MOUNT

PROPOSED TOWER EQUIPMENT

6

188 INVERNESS DRIVE WEST
SUITE 400
ENGLEWOOD, CO 80112

6615 TOWPATH ROAD
EAST SYRACUSE, NY 13057

520 South Main Street, Suite 2531
Akron, OH 44311
330.572.2100 Fax 330.572.2101
Copyright: Glau, Pyle, Schomer, Burns & DeHaven, Inc. 2025

GPD JOB #:	2025705.79
DRAWN BY:	ACM
CHECKED BY:	LJB
RFDS:	25309

REV	DATE	DESCRIPTION
0	08/27/2025	FOR CONSTRUCTION
C	08/15/2025	REV. PER COMMENTS
B	08/12/2025	REV. PER COMMENTS
A	06/05/2025	ISSUED FOR REVIEW

IT IS A VIOLATION OF LAW FOR ANY PERSON, UNLESS THEY ARE ACTING UNDER THE DIRECTION OF A LICENSED PROFESSIONAL ENGINEER, TO ALTER THIS DOCUMENT.

SHANNON PARK
SOH3625
6790 COFFMAN RD
DUBLIN, OH 43017
COLOCATION

SHEET TITLE
TOWER ELEVATION,
ANTENNA AND COAX
PLANS

SHEET NUMBER
T-1



GPD JOB #: 2025705.79
 DRAWN BY: ACM
 CHECKED BY: LJB
 RFDS: 25309

REV	DATE	DESCRIPTION
0	08/27/2025	FOR CONSTRUCTION
C	08/15/2025	REV. PER COMMENTS
B	08/12/2025	REV. PER COMMENTS
A	06/05/2025	ISSUED FOR REVIEW



IT IS A VIOLATION OF LAW FOR ANY PERSON, UNLESS THEY ARE ACTING UNDER THE DIRECTION OF A LICENSED PROFESSIONAL ENGINEER, TO ALTER THIS DOCUMENT.

SHANNON PARK
 SOH3625
 6790 COFFMAN RD
 DUBLIN, OH 43017
 COLOCATION

SHEET TITLE
 ANTENNA AND COAX
 SCHEDULE

SHEET NUMBER
T-1.1

FINAL ANTENNA AND COAXIAL CABLE SCHEDULE										
ALPHA										
POSITION	STATUS	AZIMUTH	ANTENNA TYPE	ANTENNA RAD CENTER	MAIN COAX SIZE	MAIN COAX LENGTH	COAX QTY	RAYCAP DEMARC SQUID	DC/ FIBER CABLES	RRUs QTY ON TOWER
A1	NEW	40°	COMMSCOPE NNHH-65B-R4	125'	-	-	-	(1) DC9-48-60-24-8C-EV	(2) PWRT-606-S (1) RFFT-48SM-001	(1) 4490 B5/B12A
A2	NEW	40°	ERICSSON AIR6472 B77G B77M	127.5'	-	-	-	-	-	-
A3	NEW	40°	COMMSCOPE NNH4-65C-R6-V3	125'	-	-	-	-	-	(1) 4494 B14/B29 (1) 4890 B25/B66
BETA										
B1	NEW	155°	COMMSCOPE NNHH-65B-R4	125'	-	-	-	(1) DC9-48-60-24-8C-EV	(2) PWRT-606-S (1) RFFT-48SM-001	(1) 4490 B5/B12A
B2	NEW	155°	ERICSSON AIR6472 B77G B77M	127.5'	-	-	-	-	-	-
B3	NEW	155°	COMMSCOPE NNH4-65C-R6-V3	125'	-	-	-	-	-	(1) 4494 B14/B29 (1) 4890 B25/B66
GAMMA										
C1	NEW	295°	COMMSCOPE NNHH-65B-R4	125'	-	-	-	-	-	(1) 4490 B5/B12A
C2	NEW	295°	ERICSSON AIR6472 B77G B77M	127.5'	-	-	-	-	-	-
C3	NEW	295°	COMMSCOPE NNH4-65C-R6-V3	125'	-	-	-	-	-	(1) 4494 B14/B29 (1) 4890 B25/B66



ERICSSON AIR 6472 B77G B77M
 DIMENSIONS, HxWxD: 36.3"x15.8"x7.4"
 (mm) 922x402x188mm
 TOTAL WEIGHT: 77.2 lbs

COMMSCOPE NNHH-65B-R4
 DIMENSIONS, HxWxD: 71.969"x19.606"x7.756"
 DIMENSIONS (mm): 1828x496x197mm
 TOTAL WEIGHT: 68.343 lbs

DETAIL NOT USED NO SCALE 1

PROPOSED ANTENNA SPECIFICATIONS NO SCALE 2

PROPOSED ANTENNA SPECIFICATIONS NO SCALE 3

ERICSSON RADIO 4494 B14/B29
 DIMENSIONS, WxDxH: 20.6"x15.6"x5.9"
 (mm) 522x397x149
 TOTAL WEIGHT: 57.3 lbs

ERICSSON RADIO 4890 B25/66
 DIMENSIONS, HxWxD: 17.5"x15.1"x6.9"
 (mm) 444x384x176mm
 POWER CONSUMPTION: 480 WATTS
 TOTAL WEIGHT: 68 lbs

COMMSCOPE NNH4-65C-R6-V3
 DIMENSIONS, HxWxD: 95.984"x19.606"x7.756"
 DIMENSIONS (mm): 2435x496x197mm
 TOTAL WEIGHT: 89.267 lbs

RRU SPECIFICATIONS NO SCALE 4

RRU SPECIFICATIONS NO SCALE 5

PROPOSED ANTENNA SPECIFICATIONS NO SCALE 6

ERICSSON RADIO 4490 B5/12A
 DIMENSIONS, HxWxD: 20.6"x15.6"x7"
 (mm) 524x397x178mm
 POWER CONSUMPTION: 480W
 TOTAL WEIGHT: 65 lbs

RAYCAP DC9-48-60-24-8C-EV
 DIMENSIONS, HxWxD: 31.5"x13.5"x10.25"
 (mm) 444x384x176mm
 TOTAL WEIGHT: 26.2 lbs

NOTES:
 1. UNIT SHALL BE MOUNTED AS PER MANUFACTURER'S RECOMMENDATIONS.
 2. CONTRACTOR SHALL TIGHTEN ALL BOLTS TO A "SNUG TIGHT" CONDITION AS DEFINED BY AISC
 3. CONTRACTOR SHALL INSTALL RAYCAP DISTRIBUTION UNIT WITHIN 15 FEET FROM ALL RRRHS.

RRU SPECIFICATIONS NO SCALE 7

SURGE SPECIFICATIONS NO SCALE 8

SURGE MOUNTING DETAIL NO SCALE 9

188 INVERNESS DRIVE WEST
 SUITE 400
 ENGLEWOOD, CO 80112

6615 TOWPATH ROAD
 EAST SYRACUSE, NY 13057

GPD JOB #:	2025705.79
DRAWN BY:	ACM
CHECKED BY:	LJB
RFDS:	25309

REV	DATE	DESCRIPTION
0	08/27/2025	FOR CONSTRUCTION
C	08/15/2025	REV. PER COMMENTS
B	08/12/2025	REV. PER COMMENTS
A	06/05/2025	ISSUED FOR REVIEW

REFERENCE ONLY

IT IS A VIOLATION OF LAW FOR ANY PERSON, UNLESS THEY ARE ACTING UNDER THE DIRECTION OF A LICENSED PROFESSIONAL ENGINEER, TO ALTER THIS DOCUMENT.

SHANNON PARK
 SOH3625
 6790 COFFMAN RD
 DUBLIN, OH 43017
 COLOCATION

SHEET TITLE
EQUIPMENT DETAILS

SHEET NUMBER
T-2

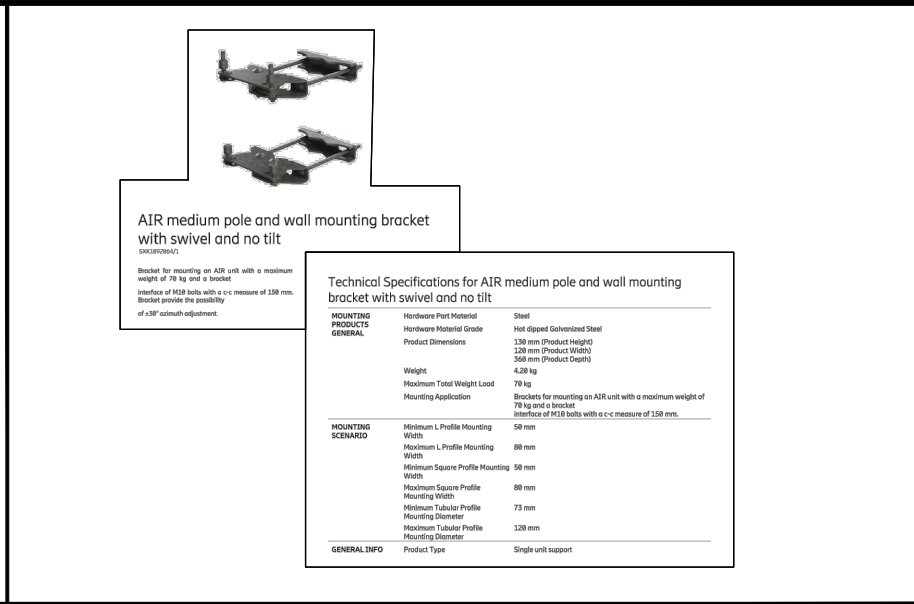
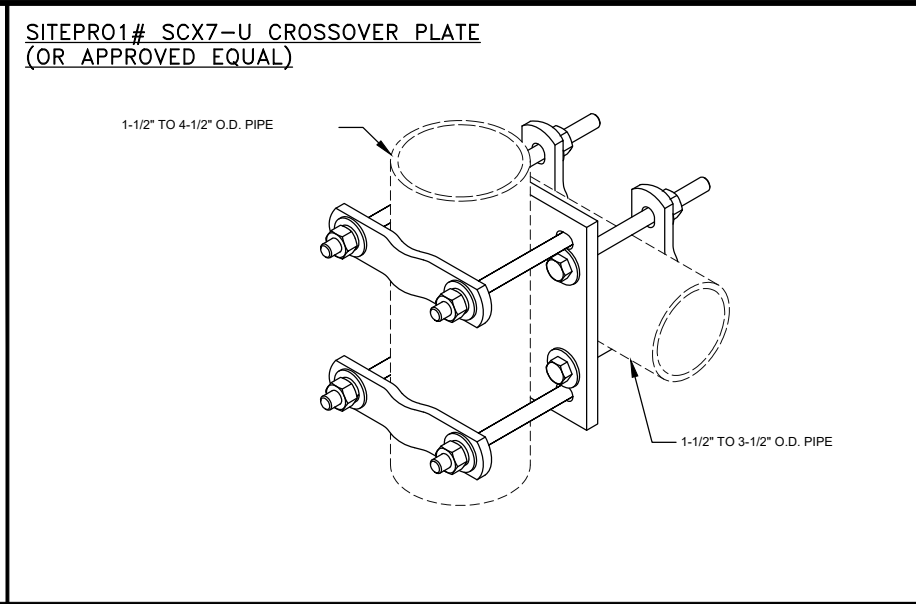
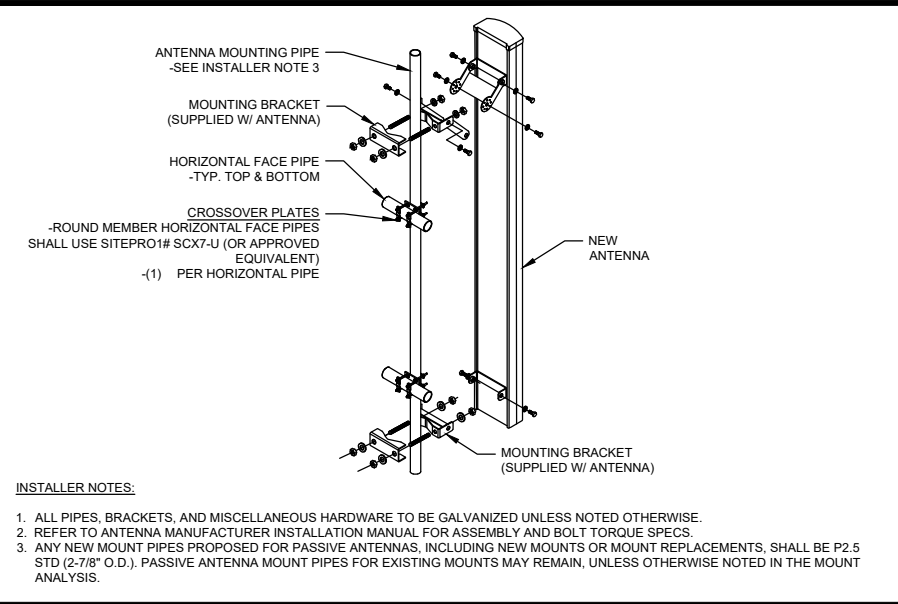

ANTENNA PIPE MOUNTING DETAIL

NO SCALE 1

CROSSOVER PLATE KIT

NO SCALE 2

AIR 6472 MOUNTING BRACKET

NO SCALE 3

DETAIL NOT USED

DETAIL NOT USED

NO SCALE 5

DETAIL NOT USED

DETAIL NOT USED

DETAIL NOT USED

NO SCALE 5

DETAIL NOT USED

DETAIL NOT USED

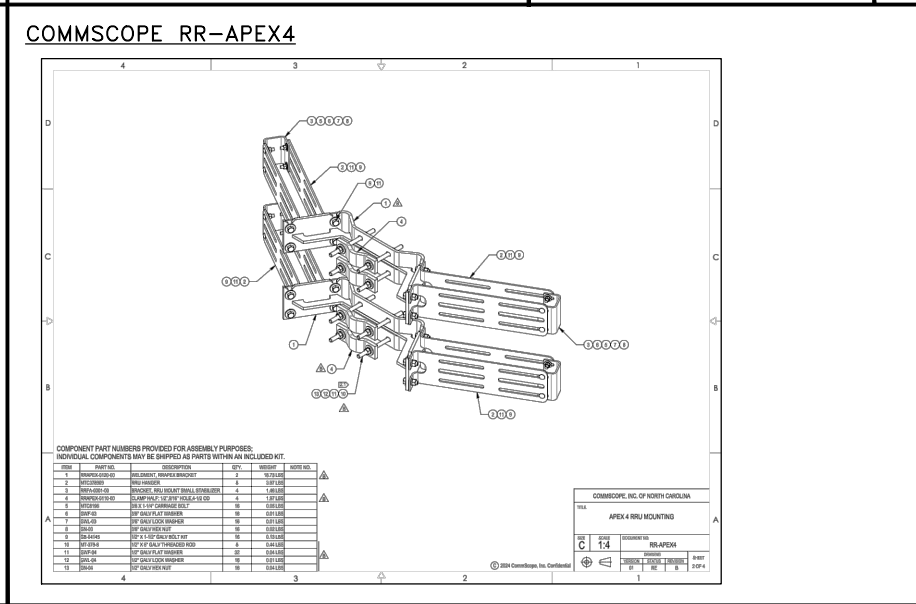

RRU MOUNTING DETAIL

NO SCALE 8

DETAIL NOT USED

GPD JOB #:	2025705.79
DRAWN BY:	ACM
CHECKED BY:	LJB
RFDS:	25309

REV	DATE	DESCRIPTION
0	08/27/2025	FOR CONSTRUCTION
C	08/15/2025	REV. PER COMMENTS
B	08/12/2025	REV. PER COMMENTS
A	06/05/2025	ISSUED FOR REVIEW

REFERENCE ONLY

IT IS A VIOLATION OF LAW FOR ANY PERSON, UNLESS THEY ARE ACTING UNDER THE DIRECTION OF A LICENSED PROFESSIONAL ENGINEER, TO ALTER THIS DOCUMENT.

SHANNON PARK
SOH3625
6790 COFFMAN RD
DUBLIN, OH 43017
COLOCATION

SHEET TITLE
EQUIPMENT DETAILS

SHEET NUMBER
T-3



188 INVERNESS DRIVE WEST
SUITE 400
ENGLEWOOD, CO 80112



6615 TOWPATH ROAD
EAST SYRACUSE, NY 13057

GPD JOB #:	2025705.79
DRAWN BY:	ACM
CHECKED BY:	LJB
RFDS:	25309

REV	DATE	DESCRIPTION
0	08/27/2025	FOR CONSTRUCTION
C	08/15/2025	REV. PER COMMENTS
B	08/12/2025	REV. PER COMMENTS
A	06/05/2025	ISSUED FOR REVIEW

REFERENCE ONLY

IT IS A VIOLATION OF LAW FOR ANY PERSON, UNLESS THEY ARE ACTING UNDER THE DIRECTION OF A LICENSED PROFESSIONAL ENGINEER, TO ALTER THIS DOCUMENT.

SHANNON PARK
SOH3625
6790 COFFMAN RD
DUBLIN, OH 43017
COLOCATION

SHEET TITLE
EQUIPMENT DETAILS

SHEET NUMBER

T-5

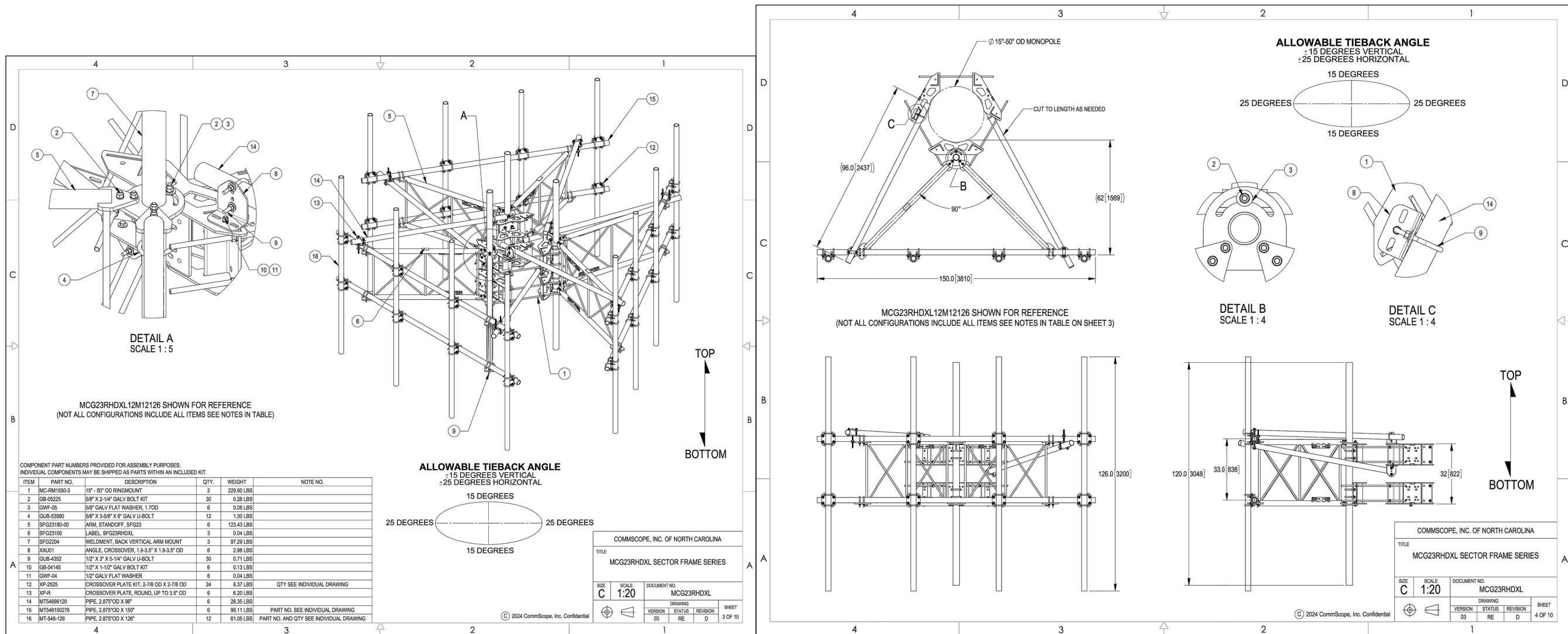

Sector A

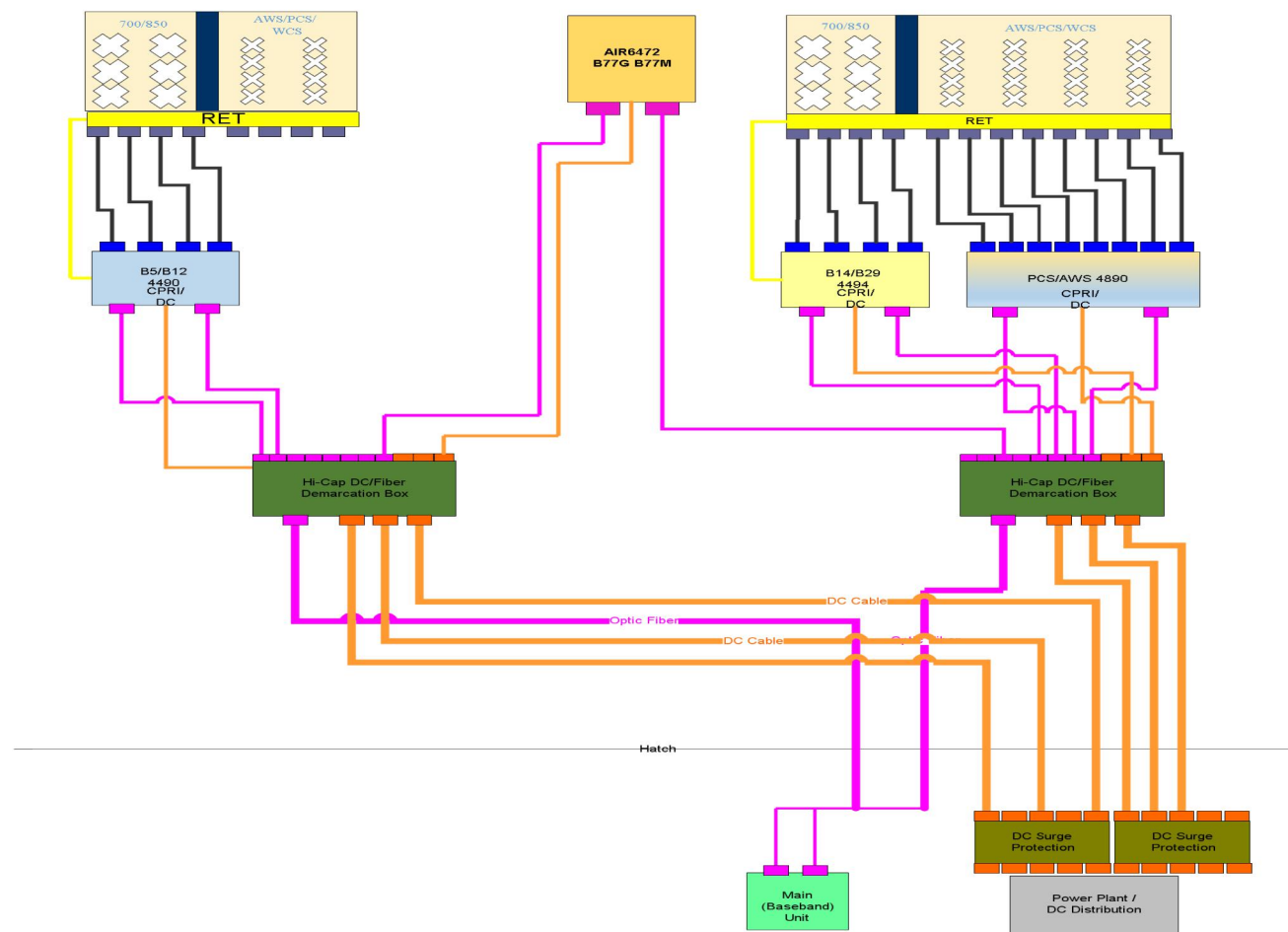

188 INVERNESS DRIVE WEST
SUITE 400
ENGLEWOOD, CO 80112

6615 TOWPATH ROAD
EAST SYRACUSE, NY 13057

GPD JOB #:	2025705.79
DRAWN BY:	ACM
CHECKED BY:	LJB
RFDS:	25309

REV	DATE	DESCRIPTION
0	08/27/2025	FOR CONSTRUCTION
C	08/15/2025	REV. PER COMMENTS
B	08/12/2025	REV. PER COMMENTS
A	06/05/2025	ISSUED FOR REVIEW

REFERENCE ONLY

IT IS A VIOLATION OF LAW FOR ANY PERSON, UNLESS THEY ARE ACTING UNDER THE DIRECTION OF A LICENSED PROFESSIONAL ENGINEER, TO ALTER THIS DOCUMENT.

SHANNON PARK
SOH3625
6790 COFFMAN RD
DUBLIN, OH 43017
COLOCATION

SHEET TITLE
PLUMBING DIAGRAM

SHEET NUMBER
T-6

Sector B

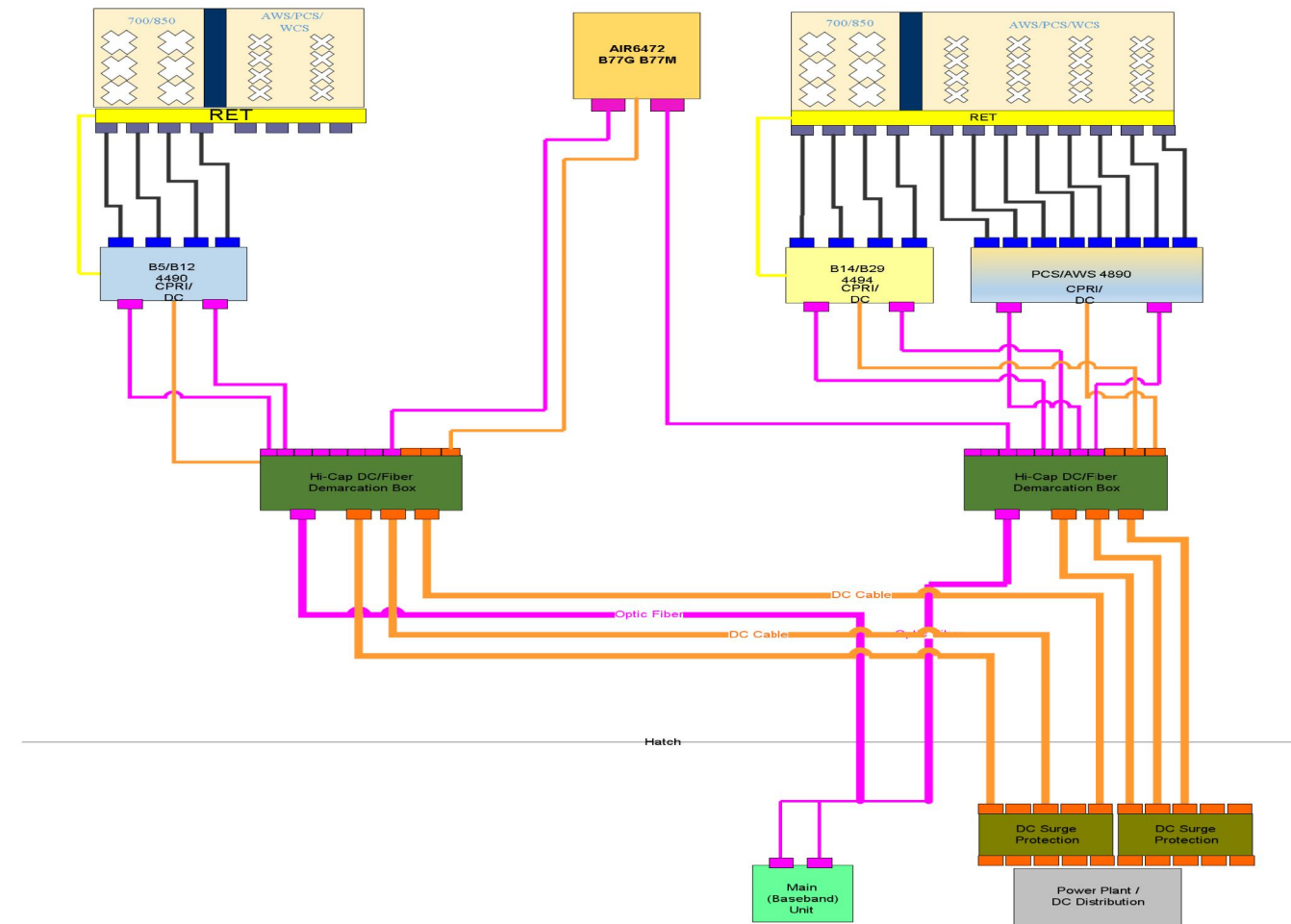

188 INVERNESS DRIVE WEST
SUITE 400
ENGLEWOOD, CO 80112

6615 TOWPATH ROAD
EAST SYRACUSE, NY 13057

GPD JOB #:	2025705.79
DRAWN BY:	ACM
CHECKED BY:	LJB
RFDS:	25309

REV	DATE	DESCRIPTION
0	08/27/2025	FOR CONSTRUCTION
C	08/15/2025	REV. PER COMMENTS
B	08/12/2025	REV. PER COMMENTS
A	06/05/2025	ISSUED FOR REVIEW

REFERENCE ONLY

IT IS A VIOLATION OF LAW FOR ANY PERSON, UNLESS THEY ARE ACTING UNDER THE DIRECTION OF A LICENSED PROFESSIONAL ENGINEER, TO ALTER THIS DOCUMENT.

SHANNON PARK
SOH3625
6790 COFFMAN RD
DUBLIN, OH 43017
COLOCATION

SHEET TITLE
PLUMBING DIAGRAM

SHEET NUMBER
T-7

Sector C

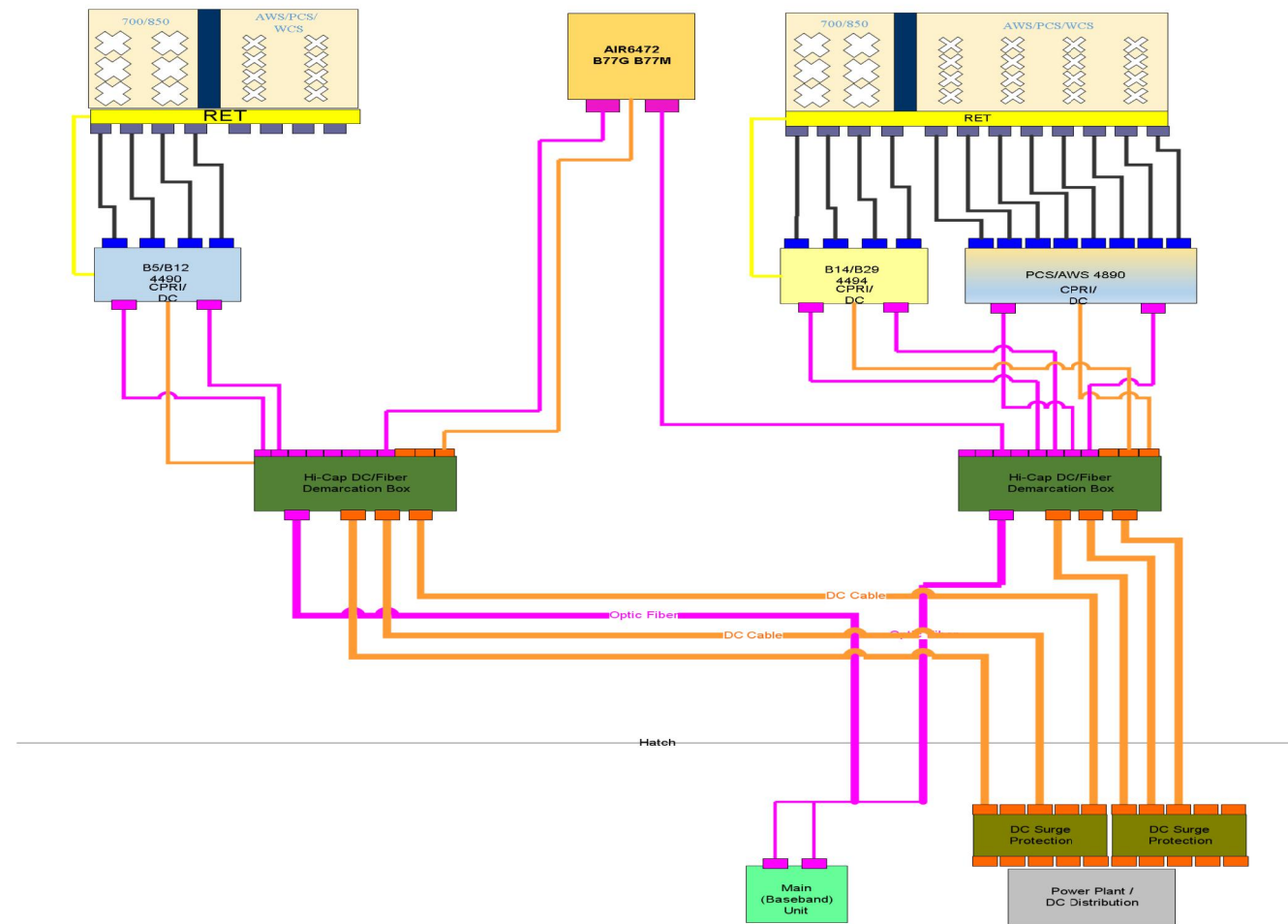

GPD JOB #:	2025705.79
DRAWN BY:	ACM
CHECKED BY:	LJB
RFDS:	25309

REV	DATE	DESCRIPTION
0	08/27/2025	FOR CONSTRUCTION
C	08/15/2025	REV. PER COMMENTS
B	08/12/2025	REV. PER COMMENTS
A	06/05/2025	ISSUED FOR REVIEW

REFERENCE ONLY

IT IS A VIOLATION OF LAW FOR ANY PERSON, UNLESS THEY ARE ACTING UNDER THE DIRECTION OF A LICENSED PROFESSIONAL ENGINEER, TO ALTER THIS DOCUMENT.

SHANNON PARK
SOH3625
6790 COFFMAN RD
DUBLIN, OH 43017
COLOCATION

SHEET TITLE
PLUMBING DIAGRAM

SHEET NUMBER
T-8

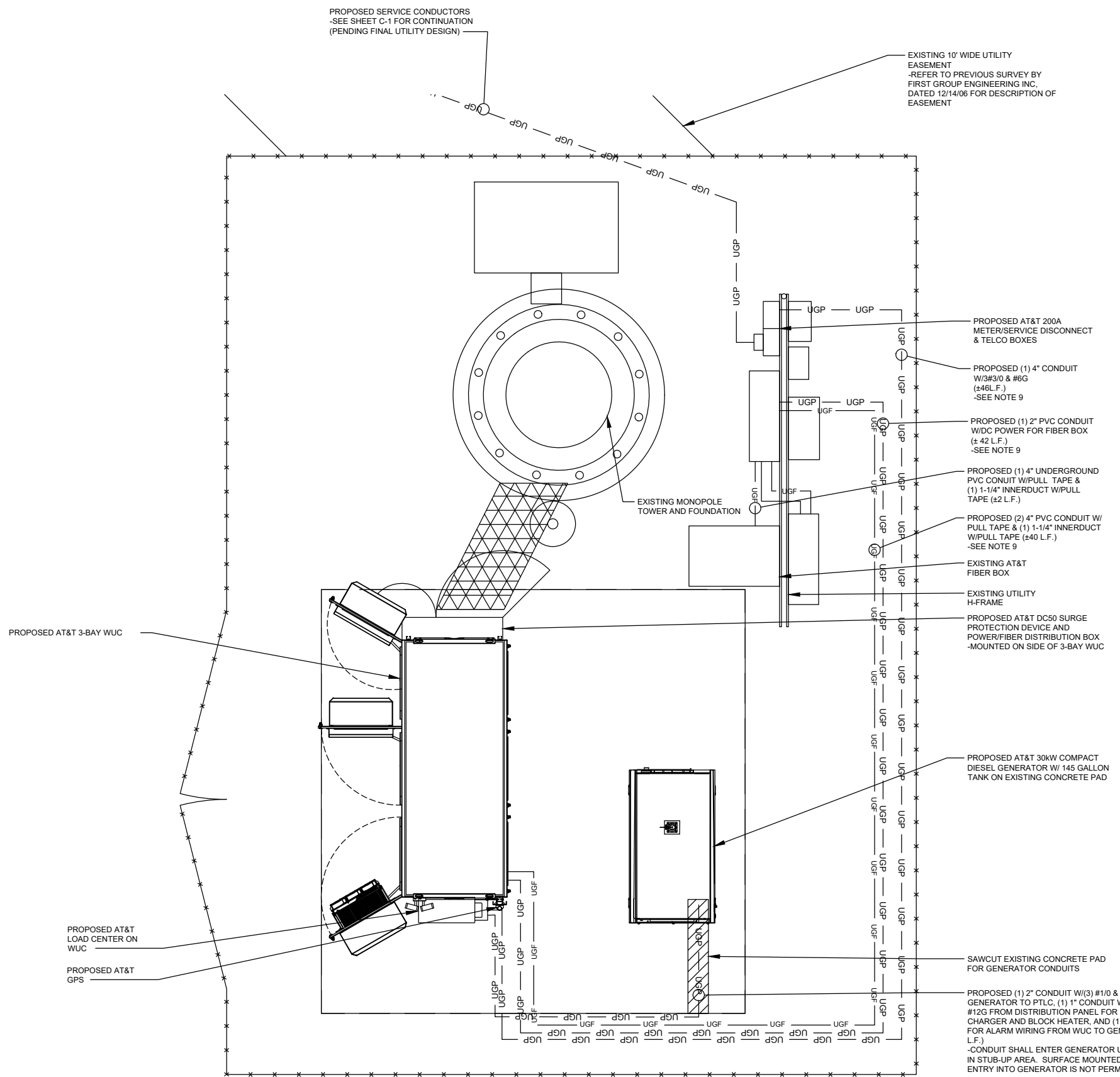

PROPOSED SERVICE CONDUCTORS
-SEE SHEET C-1 FOR CONTINUATION
(PENDING FINAL UTILITY DESIGN)

EXISTING 10' WIDE UTILITY
EASEMENT
-REFER TO PREVIOUS SURVEY BY
FIRST GROUP ENGINEERING INC.,
DATED 12/14/06 FOR DESCRIPTION OF
EASEMENT

PROPOSED AT&T 3-BAY WUC

PROPOSED AT&T
LOAD CENTER ON
WUC
PROPOSED AT&T
GPS

PROPOSED AT&T 200A
METER/SERVICE DISCONNECT
& TELCO BOXES

PROPOSED (1) 4" CONDUIT
W/3#3/0 & #6G
(±46L.F.)
-SEE NOTE 9

PROPOSED (1) 2" PVC CONDUIT
W/DC POWER FOR FIBER BOX
(±42 L.F.)
-SEE NOTE 9

PROPOSED (1) 4" UNDERGROUND
PVC CONDUIT W/PULL TAPE &
(1) 1-1/4" INNERDUCT W/PULL
TAPE (±2 L.F.)

PROPOSED (2) 4" PVC CONDUIT W/
PULL TAPE & (1) 1-1/4" INNERDUCT
W/PULL TAPE (±40 L.F.)
-SEE NOTE 9

EXISTING AT&T
FIBER BOX

EXISTING UTILITY
H-FRAME

PROPOSED AT&T DC50 SURGE
PROTECTION DEVICE AND
POWER/FIBER DISTRIBUTION BOX
-MOUNTED ON SIDE OF 3-BAY WUC

PROPOSED AT&T 30KW COMPACT
DIESEL GENERATOR W/ 145 GALLON
TANK ON EXISTING CONCRETE PAD

SAWCUT EXISTING CONCRETE PAD
FOR GENERATOR CONDUITS

PROPOSED (1) 2" CONDUIT W/3) #1/0 & (1) #6G FROM
GENERATOR TO PTL/C, (1) 1" CONDUIT W/4) #12 & (2)
#12G FROM DISTRIBUTION PANEL FOR BATTERY
CHARGER AND BLOCK HEATER, AND (1) 1" CONDUIT
FOR ALARM WIRING FROM WUC TO GENERATOR(±12
L.F.)
-CONDUIT SHALL ENTER GENERATOR UNDERGROUND
IN STUB-UP AREA. SURFACE MOUNTED CONDUIT
ENTRY INTO GENERATOR IS NOT PERMITTED.

1. THE CONDUIT ROUTING IS DIAGRAMMATICALLY SHOWN ON THE PLANS AND ARE ONLY APPROXIMATIONS. THE EXACT LOCATION AND ROUTING SHALL BE FIELD VERIFIED.
2. ALL ELECTRICAL EQUIPMENT AND CONTROLLING DEVICES SHALL BE PROVIDED WITH ENGRAVED LAMICOID NAMEPLATES, INDICATING THE CIRCUITS ORIGINATION AND ALL EQUIPMENT TERMINATIONS.
3. CONTRACTOR SHALL PROVIDE STRAIN-RELIEF AND CABLE SUPPORTS FOR ALL CABLE ASSEMBLIES, COAX CABLES, AND RET CONTROL CABLES. CABLE STRAIN-RELIEFS, CABLE SUPPORTS SHALL BE APPROVED FOR THE PURPOSE. INSTALLATION SHALL BE IN ACCORDANCE WITH THE MANUFACTURER'S SPECIFICATIONS AND RECOMMENDATIONS.
4. CONTRACTOR SHALL PROVIDE ALL BREAKERS, CONDUITS, AND CIRCUIT CONDUCTORS, AS REQUIRED FOR A COMPLETED SYSTEM AND SHALL BE IN COMPLIANCE WITH THE MANUFACTURER'S SPECIFICATIONS.
5. WHEN ADDITIONAL +24Vdc TO -48Vdc CONVERTERS ARE REQUIRED FOR LTE EQUIPMENT, ADDITIONAL +24Vdc RECTIFICATION & ADDITIONAL BATTERIES MAY BE REQUIRED TO BE ADDED TO THE EXISTING BATTERY STRING. CONTRACTOR SHALL BE RESPONSIBLE FOR ALL BREAKERS, RECTIFIERS, BATTERIES, CONDUIT, CABLE TRAY, & CONDUCTORS WHICH ARE REQUIRED FOR A COMPLETED, FUNCTIONING ELECTRICAL SYSTEM.
6. ALL CONDUITS SHALL BE INSTALLED IN COMPLIANCE WITH THE CURRENT NATIONAL ELECTRIC CODE (NEC) OR AS REQUIRED BY THE LOCAL JURISDICTION, WHICHEVER IS THE MOST STRINGENT.
7. PROPOSED TELCO WITH 25 PAIR ICKY-PICK CAT 5 CONDUCTOR IN (2) PROPOSED 4" SCH 40 PVC CONDUIT. CONTRACTOR TO COORDINATE WITH LOCAL TELEPHONE COMPANY. EACH 4" TELCO CONDUIT TO HAVE (2) 1-1/4" INTERDUCT CONDUITS FOR FIBER.
8. CONTRACTOR SHALL COORDINATE WITH POWER AND TELEPHONE COMPANIES, AND PROVIDE ALL MATERIALS REQUIRED, AND PROVIDE TRENCH, BACKFILL & SITE RESTORATION. DEPTH OF CONDUITS PER N.E.C., LOCAL JURISDICTION AND POWER & TELE COMPANY, WHICHEVER IS MORE STRINGENT.
9. ALL CONDUITS ROUTED ABOVE GRADE OR ON CONCRETE PAD SHALL BE INSTALLED SO AS NOT TO CAUSE TRIP HAZARD ALONG COMMON ACCESS PATHS, EQUIPMENT CLEAR WORKING AREAS, OR EQUIPMENT DOOR SWINGS. ALL EXPOSED CONDUIT ON CONCRETE PADS SHALL BE MARKED WITH BLACK AND YELLOW HAZARD MARKING TAPE FOR THE ENTIRE EXPOSED LENGTH. CONDUIT SHALL BE SECURED PER NEC

NOTES

2

UNDERGROUND DUCT	— UGD — UGD — UGD — UGD —
ABOVE GROUND TELCO	— AGT — AGT — AGT — AGT —
ABOVE GROUND POWER	— AGP — AGP — AGP — AGP —
ABOVE GROUND TELCO/POWER	— AGT/P — AGT/P —
OVERHEAD POWER	— OHP — OHP — OHP —
OVERHEAD UTILITIES	— OHU — OHU — OHU —
UNDERGROUND POWER	— UGP — UGP — UGP — UGP —
UNDERGROUND FIBER	— UGF — UGF — UGF —

LEGEND

3

188 INVERNESS DRIVE WEST
SUITE 400
ENGLEWOOD, CO 80112

6615 TOWPATH ROAD
EAST SYRACUSE, NY 13057

520 South Main Street, Suite 2531
Akron, OH 44311
330.572.2100 Fax 330.572.2101
Copyright: Glau, Pyle, Schomer, Burns & DeHaven, Inc. 2005

GPD JOB #:	2025705.79
DRAWN BY:	ACM
CHECKED BY:	LJB
RFDS:	25309

REV	DATE	DESCRIPTION
0	08/27/2025	FOR CONSTRUCTION
C	08/15/2025	REV. PER COMMENTS
B	08/12/2025	REV. PER COMMENTS
A	06/05/2025	ISSUED FOR REVIEW

STEVEN P. SCHAUB
E -76700
08/27/2025
REGISTERED PROFESSIONAL ENGINEER

IT IS A VIOLATION OF LAW FOR ANY PERSON, UNLESS THEY ARE ACTING UNDER THE DIRECTION OF A LICENSED PROFESSIONAL ENGINEER, TO ALTER THIS DOCUMENT.

SHANNON PARK
SOH3625
6790 COFFMAN RD
DUBLIN, OH 43017
COLOCATION

SHEET TITLE
UTILITY PLAN

SHEET NUMBER
E-1

UTILITY PLAN

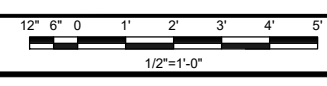

1



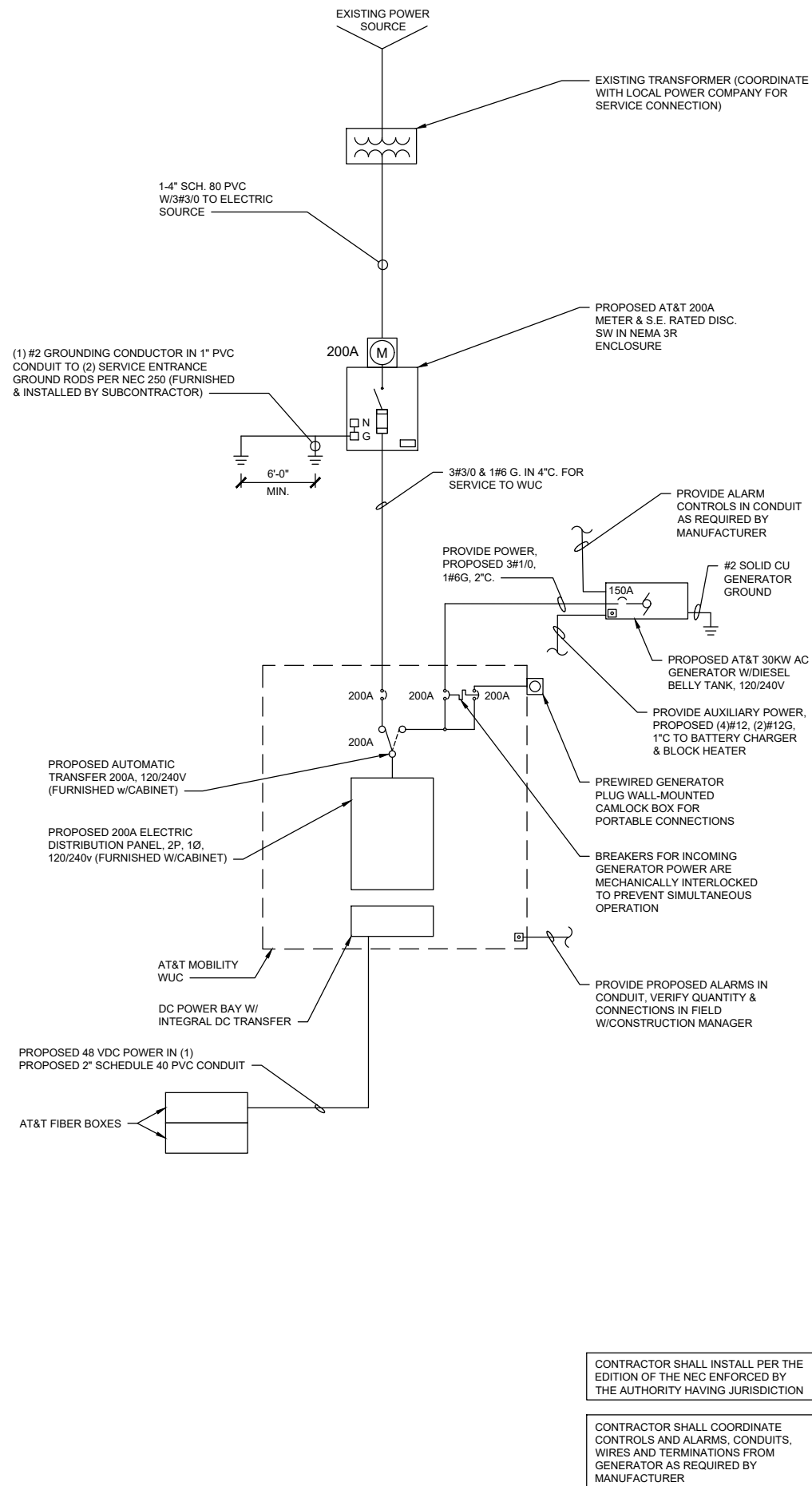

NOTES:

1. THE CONTRACTOR SHALL PROVIDE TWO SAME SIGNS ON BOTH THE OUTDOOR DISCONNECT AND THE INDOOR MAIN PANEL STATING:
 - 1.1. "ONE OPTIONAL PERMANENT STANDBY SOURCE AND ONE OPTIONAL TEMPORARY STANDBY SOURCE OF POWER ON THIS SYSTEM:
 - 1.1.1. A STANDBY GENERATOR - 30kW AC, 120/240V - TO BE LOCATED NEAR THE WALK-IN CABINET.
 - 1.1.2. A GENERATOR PLUG FOR A TEMPORARY TRAILERED GENERATOR, FLOATING NEUTRAL SYSTEM TO BE LOCATED (EQUIPMENT PERMITTING) ADJACENT TO THE WALK-IN CABINET. WARNING - SHOCK HAZARD! DO NOT DISCONNECT ANY GROUND CONDUCTORS WHILE THE GENERATOR IS IN OPERATION."
 - 1.2. THE CONTRACTOR SHALL PROVIDE A SIGN ON THE GENERATOR PLUG STATING:
 - 1.2.1. "WARNING! FOR CONNECTION OF A NON-SEPARATELY DERIVED (FLOATING NEUTRAL) SYSTEM ONLY."

SIGNAGE NOTES

NO SCALE

2

GPD JOB #:	2025705.79
DRAWN BY:	ACM
CHECKED BY:	LJB
RFDS:	25309

REV	DATE	DESCRIPTION
0	08/27/2025	FOR CONSTRUCTION
C	08/15/2025	REV. PER COMMENTS
B	08/12/2025	REV. PER COMMENTS
A	06/05/2025	ISSUED FOR REVIEW

IT IS A VIOLATION OF LAW FOR ANY PERSON, UNLESS THEY ARE ACTING UNDER THE DIRECTION OF A LICENSED PROFESSIONAL ENGINEER, TO ALTER THIS DOCUMENT.

SHANNON PARK
SOH3625
6790 COFFMAN RD
DUBLIN, OH 43017
COLOCATION

SHEET TITLE
ELECTRICAL AC ONE-LINE
DIAGRAM

SHEET NUMBER
E-2

ELECTRICAL AC ONE-LINE DIAGRAM

NO SCALE

1

DETAIL NOT USED

NO SCALE

3

A. WORK INCLUDED:

THIS SPECIFICATION AND ACCOMPANYING DRAWING CONTEMPLATE THE PROVISIONS AND INSTALLATION, BY THE ELECTRICAL CONTRACTOR OF ALL LABOR, MATERIALS AND EQUIPMENT REQUIRED TO INSTALL THE ELECTRICAL WORK COMPLETE IN CONNECTION WITH THIS AT&T MOBILITY SITE AND SHALL INCLUDE, BUT NOT BE LIMITED TO THE FOLLOWING:

1. THE PROVISIONS, INSTALLATION AND CONNECTION OF A GROUNDING ELECTRODE SYSTEM COMPLETE WITH A BUILDING AND SECONDARY GROUNDING, TOWER GROUNDING AND CONNECTIONS TO THE INCOMING ELECTRICAL DISTRIBUTION EQUIPMENT.
2. THE PROVISIONS AND INSTALLATION OF AN ELECTRICAL SERVICE AND ALL ASSOCIATED WIRE AND CONDUIT AS REQUIRED AND/OR INDICATED ON PLANS.
3. ALL UNDERGROUND CONDUITS SHALL BE SCHEDULE 40 PVC. (UNLESS OTHERWISE NOTED).
4. ALL CONDUITS SHALL BE LEFT WITH 200# TEST PULL WIRE. (UNLESS NOTED OTHERWISE) STUB & PLUG BOTH ENDS OF ALL SPARE CONDUITS UP AT 12" ABOVE GRADE.
5. THE SUBCONTRACTOR SHALL FURNISH AND INSTALL THE ELECTRICAL SERVICE ENTRANCE CONDUCTORS AND CONDUIT AND MAKE THE CONNECTION TO THE SERVICE EQUIPMENT WITHIN THE BUILDING.
6. SUBCONTRACTOR SHALL NOTIFY ELECTRIC AND TELEPHONE SERVICES CONTACT AT START OF CONSTRUCTION (2 WEEKS MIN.):

POWER CO.: AEP
CONTACT: TBD
PHONE #: (800) 672-2231

TELEPHONE CO.: AT&T
CONTACT: TBD
PHONE #: (800) 288-2020

7. ABOVE GRADE RISER CONDUIT SHALL BE GALVANIZED STEEL WITH MATCHING FITTINGS WHERE REQUIRED BY NEC.
8. THE SUBCONTRACTOR SHALL PERFORM ALL WORK SHOWN ON THE BUILDING DRAWINGS NOTED "FIELD WORK" OR OTHERWISE NOTED AS WIRING TO BE COMPLETED IN THE FIELD.
9. ALL WIRE SHALL BE (COPPER, 600V THHW, 90°C) UNLESS NOTED OTHERWISE.

B. CODES, PERMITS AND FEES:

1. ALL REQUIRED PERMITS, LICENSES, INSPECTIONS AND APPROVALS SHALL BE SECURED AND ALL FEES FOR SAME PAID BY SUBCONTRACTOR.
2. THE INSTALLATION SHALL COMPLY WITH ALL APPLICABLE CODES AND ORDINANCES; STATE, LOCAL AND NATIONAL, AND THE DESIGN, PERFORMANCE CHARACTERISTICS AND METHODS OF CONSTRUCTION OF ALL ITEMS AND EQUIPMENT, SHALL BE IN ACCORDANCE WITH THE LATEST ISSUE OF THE VARIOUS APPLICABLE STANDARD SPECIFICATIONS OF THE FOLLOWING RECOGNIZED AUTHORITIES:

A.N.S.I. - AMERICAN NATIONAL STANDARDS INSTITUTE
I.E.E.E. - INSTITUTE OF ELECTRICAL AND ELECTRONIC ENGINEERS
N.E.C. - NATIONAL ELECTRICAL CODE
N.E.M.A. - NATIONAL ELECTRICAL MANUFACTURERS ASSOCIATION
N.F.P.A. - NATIONAL FIRE PROTECTION ASSOCIATION
U.L. - UNDERWRITERS LABORATORIES, INC.
3. THE SUBCONTRACTOR SHALL BE LICENSED TO PERFORM WORK IN THE STATE, CITY OR COUNTY OF THE PROJECT SITE AS REQUIRED.

4. UTILITY COMPANY COORDINATION
ELECTRICAL CONTRACTOR SHALL COMPLETE ALL WORK IN ACCORDANCE WITH THE RULES OF THE LOCAL UTILITY COMPANY. BEFORE SUBMITTING HIS BID, THE SUBCONTRACTOR SHALL CHECK WITH THE UTILITY COMPANIES SUPPLYING SERVICE TO THIS PROJECT AND SHALL DETERMINE FROM THEM ALL EQUIPMENT AND CHARGES WHICH THEY WILL REQUIRE AND SHALL INCLUDE THE COST IN HIS BID WHENEVER POSSIBLE.

5. UTILITIES:

THE SUBCONTRACTOR SHALL BE RESPONSIBLE FOR THE EXCAVATION AND PROPER BACKFILLING OF TRENCHES AND SUPPLY CONDUIT REQUIRED FOR UNDERGROUND TELEPHONE & ELECTRICAL UTILITIES. ALL TRENCHING SHALL BE COMPACTED TO 95% MAXIMUM DRY DENSITY IN ACCORDANCE WITH ASTM D-1557 IN 6" LIFTS.

THE ELECTRICAL TRENCH SHALL START AT THE NEW PREFABRICATED RADIO EQUIPMENT BUILDING AND END AT THE NEW METER BOARD STRUCTURE. THE SUBCONTRACTOR SHALL THEN STUB THE CONDUIT 5' OUTSIDE THE FENCE. THE ELECTRIC PROVIDER SHALL PROVIDE SERVICE TO THE NEW METER BOARD STRUCTURE. THE SUBCONTRACTOR SHALL PROPERLY BACKFILL THE TRENCHES AFTER SETTLEMENT AND RESTORE GRAVEL COMPOUND. CONTACT ELECTRIC PROVIDER SIX WEEKS PRIOR TO CONSTRUCTION FOR SERVICE AND COORDINATION OF ACCESS TO SITE.

THE SUBCONTRACTOR SHALL RUN THE TELEPHONE TRENCH AND CONDUIT FROM THE NEW PREFABRICATED RADIO EQUIPMENT BUILDING TO THE NEW TELCO METER BOARD STRUCTURE. THE SUBCONTRACTOR SHALL THEN RUN CONDUIT W/PULL STRING OUTSIDE THE FENCE IN THE UTILITY EASEMENT TO THE R.O.W. THE SUBCONTRACTOR SHALL STAKE THE LOCATIONS OF THE PULL BOXES. THE TELCO PROVIDER SHALL PROVIDE SERVICE TO THE METER BOARD STRUCTURE. THE SUBCONTRACTOR SHALL PROPERLY BACKFILL THE TRENCHES AFTER SETTLEMENT AND RESTORE THE GRAVEL COMPOUND.

GENERAL NOTES

1. PROVIDE ALL SIGNAGE AS REQUIRED BY NEC AND LOCAL JURISDICTION. SEE SIGNAGE NOTES.
2. ALL ELECTRICAL WORK SHALL BE PERFORMED IN ACCORDANCE WITH THE PROJECT SPECIFICATIONS, NEC AND ALL APPLICABLE LOCAL CODES.
3. CONDUIT ROUTINGS ARE SCHEMATIC. SUBCONTRACTOR SHALL INSTALL CONDUITS SO THAT ACCESS TO EQUIPMENT IS NOT BLOCKED.
4. WIRING, RACEWAY AND SUPPORT METHODS AND MATERIALS SHALL COMPLY WITH THE REQUIREMENTS OF THE NEC AND TELCORDIA.
5. ALL CIRCUITS SHALL BE SEGREGATED AND MAINTAIN MINIMUM CABLE SEPARATION AS REQUIRED BY THE NEC AND TELCORDIA.
6. CABLES SHALL NOT BE ROUTED THROUGH LADDER-STYLE CABLE TRAY RUNGS.
7. EACH END OF EVERY POWER, POWER PHASE CONDUCTOR (I.E., HOTS), GROUNDING, AND T1 CONDUCTOR AND CABLE SHALL BE LABELED WITH COLOR-CODED INSULATION OR ELECTRICAL TAPE (3M BRAND, 1/2 INCH PLASTIC ELECTRICAL TAPE WITH UV PROTECTION, OR EQUAL). THE IDENTIFICATION METHOD SHALL CONFORM WITH NEC & OSHA.
8. ALL ELECTRICAL COMPONENTS SHALL BE CLEARLY LABELED WITH ENGRAVED LAMACOID PLASTIC LABELS. ALL EQUIPMENT SHALL BE LABELED WITH THEIR VOLTAGE RATING, PHASE CONFIGURATION, WIRE CONFIGURATION, POWER OR AMPACITY RATING, AND BRANCH CIRCUIT ID NUMBERS (I.E., PANEL BOARD AND CIRCUIT ID'S).
9. PANEL BOARDS (ID NUMBERS) AND INTERNAL CIRCUIT BREAKERS (CIRCUIT ID NUMBERS) SHALL BE CLEARLY LABELED WITH ENGRAVED LAMACOID PLASTIC LABELS.
10. ALL TIE WRAPS SHALL BE CUT FLUSH WITH APPROVED CUTTING TOOL TO REMOVE SHARP EDGES.
11. POWER, CONTROL, AND EQUIPMENT GROUND WIRING IN TUBING OR CONDUIT SHALL BE SINGLE CONDUCTOR (#14 AWG OR LARGER), 600 V, OIL RESISTANT THHN OR THWN-2, CLASS B STRANDED COPPER CABLE RATED FOR 90 °C (WET AND DRY) OPERATION; LISTED OR LABELED FOR THE LOCATION AND RACEWAY SYSTEM USED, UNLESS OTHERWISE SPECIFIED.
12. SUPPLEMENTAL EQUIPMENT GROUND WIRING LOCATED INDOORS SHALL BE SINGLE CONDUCTOR (#6 AWG OR LARGER), 600 V, OIL RESISTANT THHN OR THWN-2 GREEN INSULATION, CLASS B STRANDED COPPER CABLE RATED FOR 90 °C (WET AND DRY) OPERATION; LISTED OR LABELED FOR THE LOCATION AND RACEWAY SYSTEM USED, UNLESS OTHERWISE SPECIFIED.
13. POWER AND CONTROL WIRING, NOT IN TUBING OR CONDUIT, SHALL BE MULTI-CONDUCTOR, TYPE TC CABLE (#14 AWG OR LARGER), 600 V, OIL RESISTANT THHN OR THWN-2, CLASS B STRANDED COPPER CABLE RATED FOR 90 °C (WET AND DRY) OPERATION; WITH OUTER JACKET; LISTED OR LABELED FOR THE LOCATION USED, UNLESS OTHERWISE SPECIFIED.
14. ALL POWER AND GROUNDING CONNECTIONS SHALL BE CRIMP-STYLE, COMPRESSION WIRE LUGS AND WIRENUTS BY THOMAS AND BETTS (OR EQUAL). LUGS AND WIRENUTS SHALL BE RATED FOR OPERATION AT NO LESS THAN 75°C (90°C IF AVAILABLE).
15. RACEWAY AND CABLE TRAY SHALL BE LISTED OR LABELED FOR ELECTRICAL USE IN ACCORDANCE WITH NEMA, UL, ANSII/IEEE, AND NEC.
16. ELECTRICAL METALLIC TUBING (EMT) OR RIGID NONMETALLIC CONDUIT (I.E., RIGID PVC SCHEDULE 40, OR RIGID PVC SCHEDULE 80 FOR LOCATIONS SUBJECT TO PHYSICAL DAMAGE) SHALL BE USED FOR EXPOSED INDOOR LOCATIONS.
17. ELECTRICAL METALLIC TUBING (EMT), ELECTRICAL NONMETALLIC TUBING (ENT), OR RIGID NONMETALLIC CONDUIT (RIGID PVC, SCHEDULE 40) SHALL BE USED FOR CONCEALED INDOOR LOCATIONS.
18. GALVANIZED STEEL INTERMEDIATE METALLIC CONDUIT (IMC) SHALL BE USED FOR OUTDOOR LOCATIONS ABOVE GRADE.
19. RIGID NONMETALLIC CONDUIT (I.E., RIGID PVC SCHEDULE 40 OR RIGID PVC SCHEDULE 80) SHALL BE USED UNDERGROUND; DIRECT BURIED, IN AREAS OF OCCASIONAL LIGHT VEHICLE TRAFFIC OR ENCASED IN REINFORCED CONCRETE IN AREAS OF HEAVY VEHICLE TRAFFIC.
20. LIQUID-TIGHT FLEXIBLE METALLIC CONDUIT (LIQUID-TITE FLEX) SHALL BE USED INDOORS AND OUTDOORS, WHERE VIBRATION OCCURS OR FLEXIBILITY IS NEEDED.
21. CONDUIT AND TUBING FITTINGS SHALL BE THREADED OR COMPRESSION-TYPE AND APPROVED FOR THE LOCATION USED. SETSCREW FITTINGS ARE NOT ACCEPTABLE.
22. CABINETS, BOXES, AND WIREWAYS SHALL BE LISTED OR LABELED FOR ELECTRICAL USE IN ACCORDANCE WITH NEMA, UL, ANSII/IEEE, AND NEC.
23. WIREWAYS SHALL BE EPOXY-COATED (GRAY) AND INCLUDE A HINGED COVER, DESIGNED TO SWING OPEN DOWNWARD; SHALL BE PANDUIT TYPE E (OR EQUAL); AND RATED NEMA 1 (OR BETTER) INDOORS, OR NEMA 3R (OR BETTER) OUTDOORS.
24. EQUIPMENT CABINETS, TERMINAL BOXES, JUNCTION BOXES, AND PULL BOXES SHALL BE GALVANIZED OR EPOXY-COATED SHEET STEEL, SHALL MEET OR EXCEED UL 50, AND RATED NEMA 1 (OR BETTER) INDOORS, OR NEMA 3R (OR BETTER) OUTDOORS.
25. METAL RECEPTACLE, SWITCH, AND DEVICE BOXES SHALL BE GALVANIZED, EPOXY-COATED, OR NON-CORRODING; SHALL MEET OR EXCEED UL 514A AND NEMA OS 1; AND RATED NEMA 1 (OR BETTER) INDOORS, OR WEATHER PROTECTED (WP OR BETTER) OUTDOORS.
26. NONMETALLIC RECEPTACLE, SWITCH, AND DEVICE BOXES SHALL MEET OR EXCEED NEMA OS 2; AND RATED NEMA 1 (OR BETTER) INDOORS, OR WEATHER PROTECTED (WP OR BETTER) OUTDOORS.
27. THE SUBCONTRACTOR SHALL NOTIFY AND OBTAIN NECESSARY AUTHORIZATION FROM THE CONTRACTOR BEFORE COMMENCING WORK ON THE AC POWER DISTRIBUTION PANELS.
28. THE SUBCONTRACTOR SHALL PROVIDE NECESSARY TAGGING ON THE BREAKERS, CABLES AND DISTRIBUTION PANELS IN ACCORDANCE WITH THE APPLICABLE CODES AND STANDARDS TO SAFEGUARD AGAINST LIFE AND PROPERTY.
29. THE CONTRACTOR SHALL CO-ORDINATE WITH UTILITY COMPANY AND CALCULATE SHORT CIRCUIT FAULT CURRENT AND ARC FLASH, AND PROVIDE LABELS ON ELECTRICAL EQUIPMENT PER NEC AND LOCAL JURISDICTION. CONTRACTOR SHALL PROVIDE EQUIPMENT RATED FOR FAULT CURRENT.



188 INVERNESS DRIVE WEST
SUITE 400
ENGLEWOOD, CO 80112



6615 TOWPATH ROAD
EAST SYRACUSE, NY 13057



520 South Main Street, Suite 2531
Akron, OH 44311
330.572.2100 Fax 330.572.2101
Copyright: Claus, Pyle, Schomer, Burns & DeHaven, Inc. 2025

GPD JOB #:	2025705.79
DRAWN BY:	ACM
CHECKED BY:	LJB
RFDS:	25309

REV	DATE	DESCRIPTION
0	08/27/2025	FOR CONSTRUCTION
C	08/15/2025	REV. PER COMMENTS
B	08/12/2025	REV. PER COMMENTS
A	06/05/2025	ISSUED FOR REVIEW

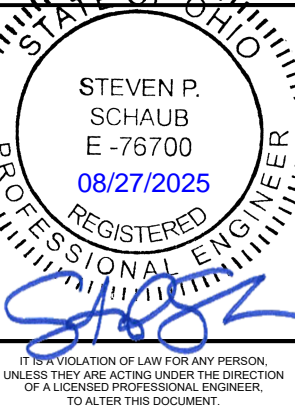

STEVEN P. SCHAUB
E -76700
08/27/2025

IT IS A VIOLATION OF LAW FOR ANY PERSON, UNLESS THEY ARE ACTING UNDER THE DIRECTION OF A LICENSED PROFESSIONAL ENGINEER, TO ALTER THIS DOCUMENT.

SHANNON PARK
SOH3625
6790 COFFMAN RD
DUBLIN, OH 43017
COLOCATION

SHEET TITLE
GENERAL ELECTRICAL
NOTES

SHEET NUMBER
E-3



GPD JOB #:	2025705.79
DRAWN BY:	ACM
CHECKED BY:	LJB
RFDS:	25309

REV	DATE	DESCRIPTION
0	08/27/2025	FOR CONSTRUCTION
C	08/15/2025	REV. PER COMMENTS
B	08/12/2025	REV. PER COMMENTS
A	06/05/2025	ISSUED FOR REVIEW

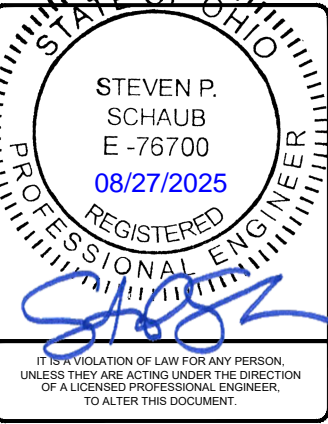

SHANNON PARK
SOH3625
6790 COFFMAN RD
DUBLIN, OH 43017
COLOCATION

SHEET TITLE
AC PANEL SCHEDULE AND NOTES

SHEET NUMBER
E-4

VOLTAGE:	120/240V	PHASE:	1	WIRE:	3
MAIN LUGS:	200 AMP	BUSS RATING:	200 AMPS	AIC:	22K (VERIFY IN FIELD. SEE NOTE 29 ON SHEET E-3)
MOUNT:	SURFACE	NEUTRAL BAR:	YES	GROUND BAR:	YES
ENCLOSURE TYPE:	NEMA 3R	N to GROUND BOND:	NO		
PANEL STATUS:	PROPOSED	INTERNAL TVSS:	YES		

CKT	LOAD DESCRIPTION	BREAKER AMPS	BREAKER POLES	BREAKER STATUS	SERVICE LOAD VA	USAGE FACTOR	PHASE A VA	PHASE B VA	USAGE FACTOR	SERVICE LOAD VA	BREAKER STATUS	BREAKER POLES	BREAKER AMPS	LOAD DESCRIPTION	CKT
1	RECTIFIER 1 & 2	25	2	ON	2150	1.00	2330		1.00	180	ON	1	20	GFCI	2
3				ON	2150	1.00		4300	1.00	2150	ON	2	25	RECTIFIER 7 & 8	4
5	RECTIFIER 3 & 4	25	2	ON	2150	1.00	4300		1.00	2150	ON				6
7				ON	2150	1.00		4300	1.00	2150	ON	2	25	RECTIFIER 9 & 10	8
9	RECTIFIER 5 & 6	25	2	ON	2150	1.00	4300		1.00	2150	ON				10
11				ON	2150	1.00		2150	1.00	0	OFF	2	30	SPARE	12
13	SPARE	30	2	OFF	0	1.00	0		1.00	0	OFF				14
15				OFF	0	1.00		144	1.00	144	ON	1	20	EXTERIOR LIGHTS	16
17	---	---	---	N/A	0	1.00	0		1.00	0	N/A	---	---	---	18
19	---	---	---	N/A	0	1.00		0	1.00	0	N/A	---	---	---	20
21	RECEPTACLE	20	1	ON	180	1.00	180		1.00	0	N/A	---	---	---	22
23	BATTERY CHARGER	15	1	ON	1200	1.00		1200	1.00	0	N/A	---	---	---	24
25	BLOCK HEATER	15	1	ON	1500	1.00	1500		1.00	0	N/A	---	---	---	26
27	---	---	---	N/A	0	1.00		0	1.00	0	N/A	---	---	---	28
29	---	---	---	N/A	0	1.00	0		1.00	0	N/A	---	---	---	30
							12610	12094	VA				TOTAL KVA	24.70	
													AMPS	102.93	

Walk Up Cabinet Schedule

NOTE: CONTRACTOR IS RESPONSIBLE TO SIZE ALL BRANCH CIRCUITS PER THE NEC, DE-RATE WIRES FOR VOLTAGE DROP AND DE-RATE FOR NUMBER OF WIRES PER CONDUIT

PANEL SCHEDULE LAYOUT PER MANUFACTURE PROVIDED SPECIFICATIONS.

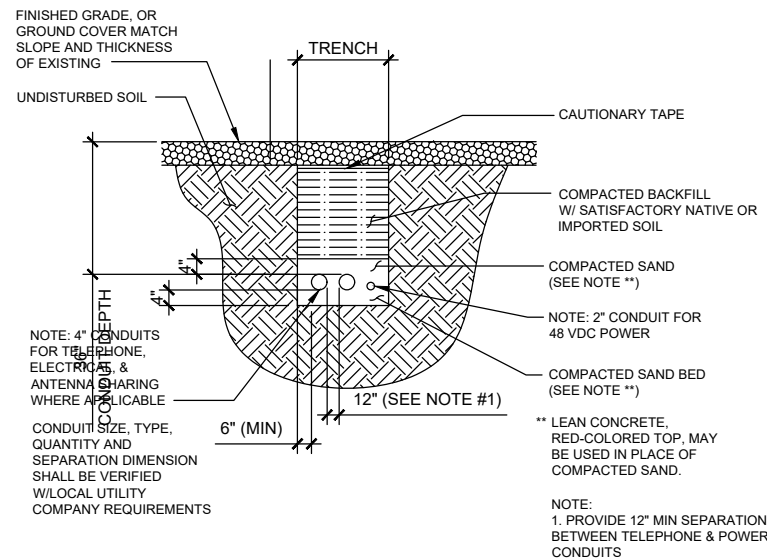

TYPICAL UTILITY TRENCH DETAIL

NO SCALE

1

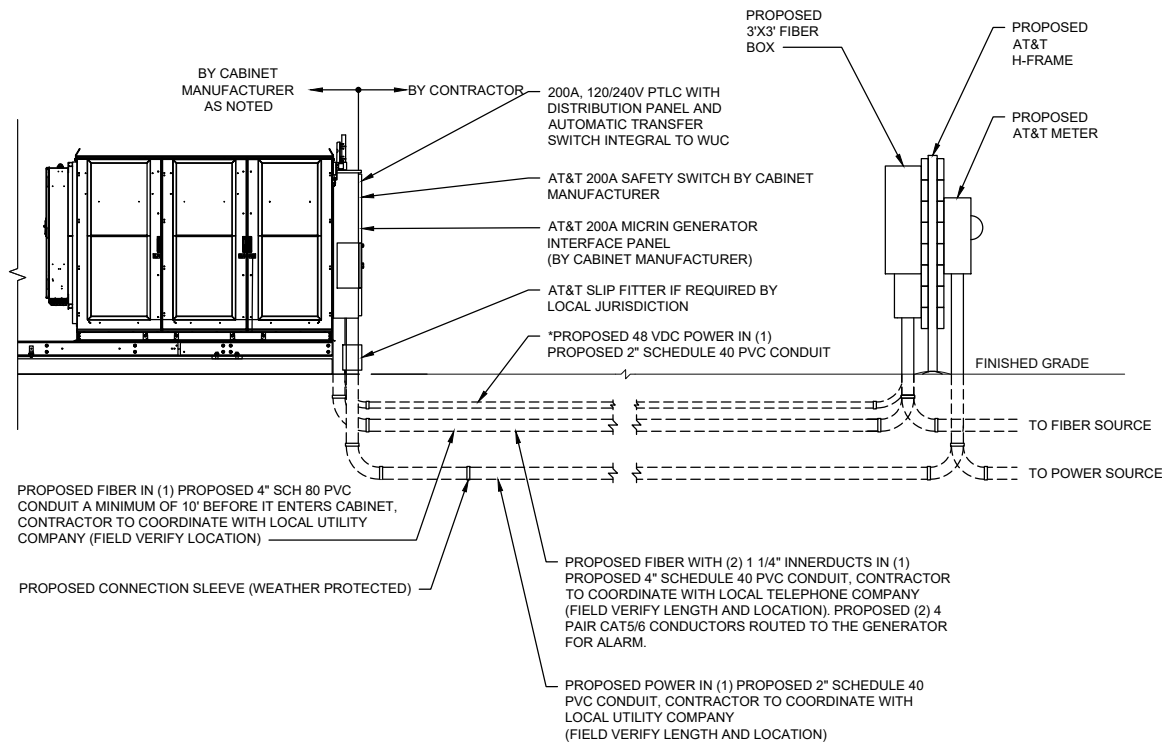

POWER RISER DIAGRAM

NO SCALE

2

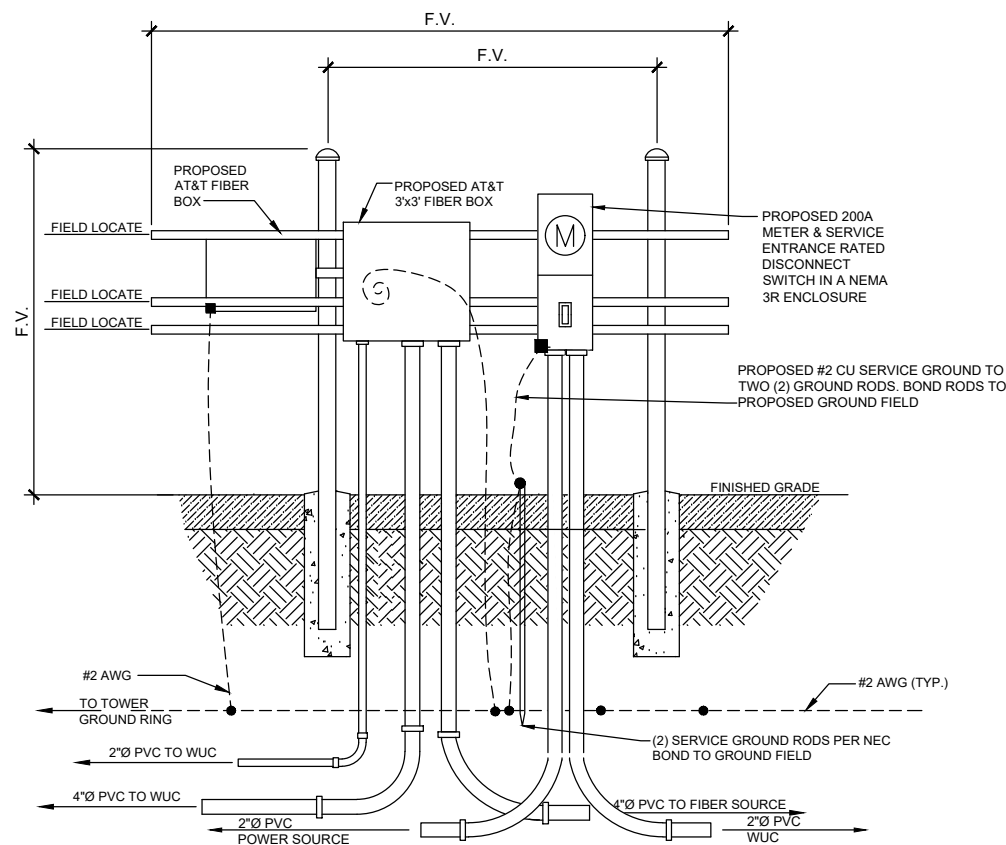

H-FRAME ELEVATION

NO SCALE

4

1. ALL UNDERGROUND CONDUITS SHALL BE SCH 40 PVC. ALL UNDERGROUND ELBOWS SHALL BE SWEEPING BENDS. 2'-0" MINIMUM SHALL BE REQUIRED.
2. TWO CONDUITS ARE SHOWN IN DETAIL 2, ALTHOUGH MULTIPLE CONDUITS CAN BE PLACED IN THE SAME TRENCH. A MINIMUM SEPARATION IS REQUIRED PER THE LOCAL JURISDICTIONS AND UTILITY COMPANIES. IN ALL OTHER CASES, USE THE TYP UTILITIES TRENCH DETAIL ON THIS SHEET TO MAINTAIN MINIMUM SPACING BETWEEN THE EXTERIOR WALL TO EXTERIOR WALL SEPARATION OF CONDUITS.
3. CONTRACTOR SHALL RESTORE THE TRENCH TO ITS ORIGINAL CONDITIONS BY EITHER SEEDING OR SODDING GRASS AREAS, OR REPLACING ASPHALT OR CONCRETE AREAS TO ITS ORIGINAL CROSS SECTION.
4. TRENCHING SAFETY, INCLUDING, BUT NOT LIMITED TO SOIL CLASSIFICATION, SLOPING, AND SHORING, SHALL BE GOVERNED BY THE CURRENT OSHA TRENCHING AND EXCAVATION SAFETY STANDARDS.
5. ALL CONDUITS SHALL BE INSTALLED IN COMPLIANCE WITH THE NATIONAL ELECTRIC CODE (NEC) OR AS REQUIRED BY THE LOCAL JURISDICTION.
6. CONTRACTOR SHALL COORDINATE WITH UTILITY COMPANY AND CALCULATE SHORT CIRCUIT FAULT CURRENT & ARC FLASH AND PROVIDE LABELS ON ELECTRICAL EQUIPMENT PER NEC & LOCAL JURISDICTION
7. CONTRACTOR SHALL VERIFY EXISTING SERVICE GROUND IS COMPLIANT W/NEC & LOCAL JURISDICTION AND FIX/REPAIR AS REQUIRED.

NOTES

5

*CONTRACTOR SHALL CONFIRM WITH CONSTRUCTION MANAGER PRIOR TO ORDERING AND INSTALLING 2" CONDUIT AS IT MAY BE DEEMED UNNECESSARY FOLLOWING THE LEC/UTILITY WALK

GPD JOB #:	2025705.79
DRAWN BY:	ACM
CHECKED BY:	LJB
RFDS:	25309

REV	DATE	DESCRIPTION
0	08/27/2025	FOR CONSTRUCTION
C	08/15/2025	REV. PER COMMENTS
B	08/12/2025	REV. PER COMMENTS
A	06/05/2025	ISSUED FOR REVIEW

STEVEN P. SCHAUB
E -76700
08/27/2025
REGISTERED PROFESSIONAL ENGINEER

IT IS A VIOLATION OF LAW FOR ANY PERSON, UNLESS THEY ARE ACTING UNDER THE DIRECTION OF A LICENSED PROFESSIONAL ENGINEER, TO ALTER THIS DOCUMENT.

SHANNON PARK
SOH3625
6790 COFFMAN RD
DUBLIN, OH 43017
COLOCATION

SHEET TITLE
ELECTRICAL DETAILS

SHEET NUMBER
E-5

DETAIL NOT USED

NO SCALE

3

- GROUNDING IS SHOWN DIAGRAMMATICALLY ONLY. FOR GROUNDING DETAILS SEE DRAWINGS E-8 THRU E-10.
- TESTING SHALL BE PERFORMED AT ALL SITES WHERE MODIFICATIONS OR ADDITIONS ARE MADE TO THE EXISTING GROUNDING SYSTEM AND SHALL BE IN ACCORDANCE WITH AT&T GROUNDING AND BONDING STANDARDS TP-76416. THE CONTRACTOR SHALL SUPPLY AT&T WITH RESULTS FROM PRE-CONSTRUCTION AND POST-CONSTRUCTION OHM TESTING (GROUNDING) RESULTS AND BE IN COMPLIANCE WITH AT&T GROUNDING AND BONDING STANDARDS TP-76416.
- THE CONTRACTOR SHALL BE RESPONSIBLE TO PROVIDE A "FALL OF POTENTIAL" TEST ON THE PROPOSED SUPPLEMENTAL GROUNDING FIELD PRIOR TO FINAL CONNECTION OF THE GROUNDING SYSTEM TO EQUIPMENT. THE TEST SHALL BE PERFORMED BY A QUALIFIED AND CERTIFIED TESTING AGENT. PROVIDE INDEPENDENT TEST RESULTS TO THE PROJECT MANAGER FOR REVIEW. THE GROUNDING SYSTEM RESISTANCE TO EARTH GROUNDING SHALL NOT EXCEED (5) OHMS. IF THE GROUNDING TEST EXCEEDS THE MAXIMUM OF (5) OHMS, THE CONTRACTOR SHALL BE RESPONSIBLE TO PROVIDE ADDITIONAL GROUNDING RODS AND CONNECTIONS AS REQUIRED TO MEET THE (5) OHMS' MAXIMUM.
- THE INSPECTOR HAVING JURISDICTION SHALL INSPECT ALL GROUNDING CONNECTIONS FOR TIGHTNESS. EXOTHERMIC WELDED CONNECTIONS SHALL BE APPROVED BEFORE BEING PERMANENTLY CONCEALED.
- FOR ALL CONNECTIONS TO THE GROUNDING RING, SEE THE SHELTER MANUFACTURER'S DRAWINGS.
- WHEN AN EXISTING METER RACK IS BEING UTILIZED AND A NEW METER IS INSTALLED IN THE EXISTING METER RACK, THE GROUNDING RODS, AND GROUNDING CONDUCTORS OF THE EXISTING GROUNDING RING, SHALL BE EXTENDED TO THE PROPOSED GROUNDING RING AND BECOME A COMPLETE GROUNDING SYSTEM.
- CONTRACTOR SHALL GROUND ALL EQUIPMENT INCLUDING ANTENNAS, RET MOTORS, TMA'S, COAX CABLES AND RET CONTROL CABLES AS A COMPLETE SYSTEM. GROUNDING SHALL BE EXECUTED BY QUALIFIED WIREMEN IN COMPLIANCE WITH MANUFACTURER'S SPECIFICATIONS AND RECOMMENDATIONS.
- WHEN A CANOPY IS INSTALLED, THE CANOPY SHALL BE EFFECTIVELY GROUNDED AS REQUIRED BY AT&T GROUNDING AND BONDING STANDARDS TP-76416.
- FOR ROOFTOP INSTALLATIONS, ROUTE GROUNDING CONDUCTORS ON THE SHELTER'S EXTERIOR SUPPORTING STRUCTURE. WHEN A SUPPORT PLATFORM STRUCTURE IS EMPLOYED, ROUTE GROUNDING CONDUCTORS UNDERNEATH AND ON THE SUPPORTING MEMBERS, USING APPROVED STRAPS AS REQUIRED IN AT&T GROUNDING AND BONDING ARTICLE 6.4.1.7 STATED IN TP-76416.
- FOR GROUNDING INSTALLATIONS WHICH HAVE A LIMITED AREA AND IS BEING REQUIRED TO BE INSTALLED WITHIN THE LEASE AREA ONLY, THE GROUNDING RING CONDUCTORS CAN BE INSTALLED UNDER THE SHELTER'S FOOTINGS.
- MAIN GROUNDING CONDUCTORS SHALL BE ROUTED AND BONDED TO ALL EFFECTIVE GROUNDING PATHS IN ACCORDANCE WITH AT&T GROUNDING AND BONDING SPECIFICATION 6.8.2 STATED IN TP-76416. THE NEW GROUNDING SYSTEM SHALL BE BONDED (2 PLACES) TO ALL EXISTING GROUNDING SYSTEMS, INCLUDING BUT NOT LIMITED TO BUILDING STEEL STRUCTURE, LIGHTNING PROTECTION SYSTEMS, BUILDING MAIN GROUNDING SYSTEM AND/OR MAIN WATER SUPPLY IF APPLICABLE.
- ON BUILDINGS AND/OR NEW TOWERS GREATER THAN 75 FEET IN HEIGHT WHERE THE MAIN GROUNDING CONDUCTORS ARE REQUIRED TO BE ROUTED TO GRADE, THE CONTRACTOR SHALL ROUTE TWO GROUNDING CONDUCTORS NOT SMALLER THAN 2/0 AWG COPPER. ROOFTOP GROUNDING RING SHALL BE BONDED TO THE EXISTING GROUNDING SYSTEM, THE BUILDING STEEL COLUMNS, LIGHTNING PROTECTION SYSTEM, AND BUILDING MAIN WATER LINE (FERROUS OR NONFERROUS METAL PIPING ONLY). SEE AT&T GROUNDING AND BONDING STANDARDS TP-76416 SPECIFICATION 6.3.2.2.
- CONNECTIONS TO THE BURIED GROUND RING SHALL BE EXOTHERMICALLY WELDED BY A CERTIFIED TECHNICIAN. CONNECTIONS TO ABOVE GROUND UNITS SHALL BE MAKE WITH EXOTHERMIC WELD, WHERE PRACTICAL, OR WITH 2 HOLE CONNECTIONS.
- GROUND WIRE SHALL HAVE A MINIMUM BEND RADIUS OF 8" AND >90°.
- ALL MECHANICAL GROUND CONNECTION SHALL HAVE AN ANTIOXIDANT COMPOUND APPLIED PRIOR TO INSTALLATION.

NOTES

1

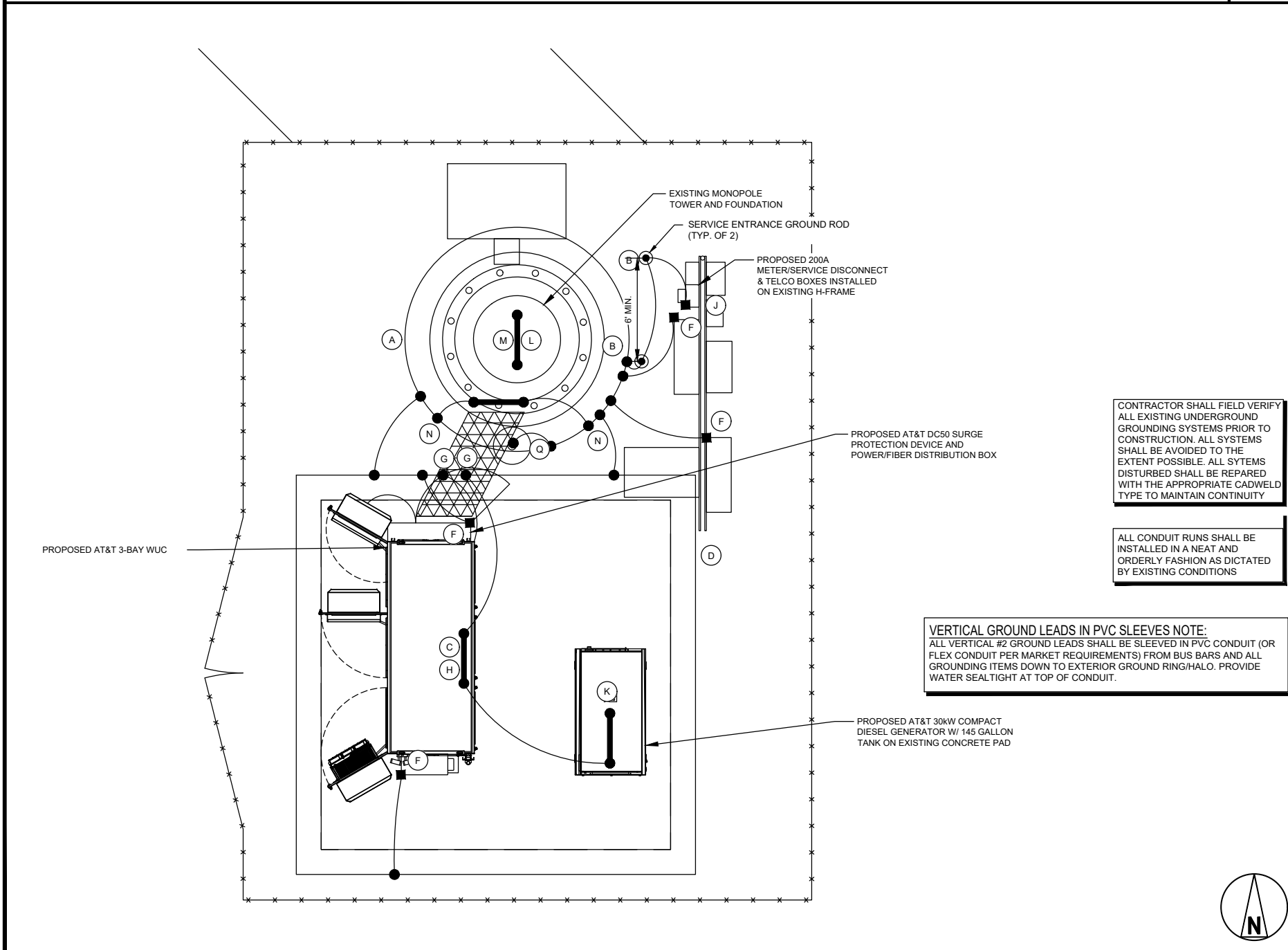

CONTRACTOR SHALL FIELD VERIFY ALL EXISTING UNDERGROUND GROUNDING SYSTEMS PRIOR TO CONSTRUCTION. ALL SYSTEMS SHALL BE AVOIDED TO THE EXTENT POSSIBLE. ALL SYSTEMS DISTURBED SHALL BE REPAIRED WITH THE APPROPRIATE CADWELD TYPE TO MAINTAIN CONTINUITY

ALL CONDUIT RUNS SHALL BE INSTALLED IN A NEAT AND ORDERLY FASHION AS DICTATED BY EXISTING CONDITIONS

VERTICAL GROUND LEADS IN PVC SLEEVES NOTE:
ALL VERTICAL #2 GROUND LEADS SHALL BE SLEEVED IN PVC CONDUIT (OR FLEX CONDUIT PER MARKET REQUIREMENTS) FROM BUS BARS AND ALL GROUNDING ITEMS DOWN TO EXTERIOR GROUND RING/HALO. PROVIDE WATER SEALTIGHT AT TOP OF CONDUIT.

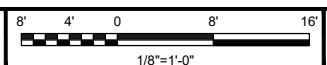

2

GROUNDING SITE PLAN

- EXISTING TOWER GROUND RING, FIELD VERIFY: WHERE SEPARATE SYSTEMS HAVE BEEN PROVIDED FOR THE TOWER AND THE BUILDING, AT LEAST TWO BONDS SHALL BE MADE BETWEEN THE EXISTING TOWER RING GROUND SYSTEM AND THE BUILDING RING GROUND SYSTEM USING MINIMUM #2 AWG SOLID COPPER CONDUCTORS. (ATT-TP-76416 7.5.1) (FIELD VERIFY LOCATION)
- GROUND ROD: UL LISTED COPPER CLAD STEEL. MINIMUM 3/4" DIAMETER BY TEN FEET LONG. ALL GROUND RODS MAY BE INSTALLED WITH INSPECTION SLEEVES. GROUND RODS SHALL BE DRIVEN TO THE DEPTH OF GROUND RING CONDUCTOR. (ATT-TP-76416 1.4 / 2.2.3.10) [NOT DRAWN TO SCALE IN PLAN]
- WUC GROUND BAR: POINT OF GROUND REFERENCE FOR ALL COMMUNICATION EQUIPMENT FRAMES. ALL BONDS ARE MADE WITH #2 AWG STRANDED GREEN INSULATED COPPER CONDUCTORS. BOND TO TOWER GROUND RING WITH (2) #2 SOLID TINNED COPPER CONDUCTORS AND TO HELICAL PIERS WITH (2) 2AWG STC CONDUCTORS (ATT-TP-76416 7.6.7)
- EXISTING CONCRETE PAD GROUND RING, FIELD VERIFY:
- NOT USED
- EXTERIOR UNIT BONDS: METALLIC OBJECTS, EXTERNAL TO OR MOUNTED TO THE BUILDING, SHALL BE BONDED TO THE TOWER GROUND RING. (ATT-TP-76416 7.12.2)
- CABINET GROUND: (1) 2 AWG INSULATED CONDUCTOR FROM THE EXTERNAL CHASSIS GROUND LUG TO THE EQUIPMENT PAD GROUND RING. EXOTHERMIC WELD AT GROUND RING
- DURING ALL DC POWER SYSTEM CHANGES INCLUDING DC SYSTEM CHANGE OUTFS, RECTIFIER REPLACEMENTS OR ADDITIONS, BREAKER DISTRIBUTION CHANGES, BATTERY ADDITIONS, BATTERY REPLACEMENTS AND INSTALLATIONS OR CHANGES TO DC CONVERTER SYSTEMS IT SHALL BE REQUIRED THAT SERVICES CONTRACTORS VERIFY ALL DC POWER SYSTEMS ARE EQUIPPED WITH A MASTER DC SYSTEM RETURN GROUND CONDUCTOR FROM THE DC POWER SYSTEM COMMON RETURN BUS DIRECTLY CONNECTED TO THE CELL SITE REFERENCE GROUND BAR (CRGB) PER AT&T-TP-76300 SECTION H 6 AND AT&T-TP-76416 FIGURE 7-11 REQUIREMENTS.
- ELECTRICAL SERVICE GROUND: EXTEND #2/0 BARE TINNED COPPER GROUND WIRE FROM NEUTRAL BUS BAR IN METER CABINET TO POWER COMPANY GROUND.
- GENERATOR GROUND BAR: EXTEND (1) #2 AWG SOLID TINNED BOND FROM GENERATOR INTERNAL GROUND BAR TO WUC GROUND BAR [NOT DRAWN TO SCALE IN PLAN]
- TOWER TOP GROUNDING BAR: MECHANICALLY BOND GROUND BAR TO STRUCTURE. [NOT DRAWN TO SCALE IN PLAN]
- ANTENNA GROUND BAR: #2 AWG SOLID TINNED COPPER BOND TO TOWER TOP GROUND BAR. [NOT DRAWN TO SCALE IN PLAN]
- TOWER EXIT GROUND BAR: MECHANICALLY SECURE THE GROUND BAR DIRECTLY TO TOWER WITH STAINLESS STEEL MOUNTING MATERIAL. CONTRACTOR TO VERIFY THAT THE STRUCTURE IS PROPERLY GROUNDED TO THE TOWER GROUND RING (ATT-TP-76416 7.5.5)
- ICE BRIDGE SUPPORTS: EACH ICE BRIDGE LEG SHALL BE BONDED TO THE GROUND RING WITH #2 AWG BARE TINNED COPPER CONDUCTOR. PROVIDE EXOTHERMIC WELDS AT BOTH THE ICE BRIDGE LEG AND BURIED GROUND RING. (ATT-TP-76416 7.4.2.6)
- NOT USED

GROUNDING KEYED NOTES

3

SYMBOL	DESCRIPTION
●	3/4" x 10' COPPER CLAD STEEL GROUND ROD
⊙	3/4" x 10' COPPER CLAD TEST WELL GROUND ROD W/INSPECTION SLEEVE
●	EXOTHERMIC WELD (CADWELD) (UNLESS OTHERWISE NOTED)
⊙	EXOTHERMIC WELD (CADWELD) WITH INSPECTION SLEEVE
■	MECHANICALLY BONDED GROUND CONNECTION

LEGEND

NO SCALE

4

188 INVERNESS DRIVE WEST
SUITE 400
ENGLEWOOD, CO 80112

6615 TOWPATH ROAD
EAST SYRACUSE, NY 13057

520 South Main Street, Suite 2531
Akron, OH 44311
330.572.2100 Fax 330.572.2101
Copyright: Glau, Pyle, Schomer, Burns & DeHaven, Inc. 2025

GPD JOB #:	2025705.79
DRAWN BY:	ACM
CHECKED BY:	LJB
RFDS:	25309

REV	DATE	DESCRIPTION
0	08/27/2025	FOR CONSTRUCTION
C	08/15/2025	REV. PER COMMENTS
B	08/12/2025	REV. PER COMMENTS
A	06/05/2025	ISSUED FOR REVIEW

STEVEN P. SCHAUB
E -76700
08/27/2025
REGISTERED PROFESSIONAL ENGINEER

IT IS A VIOLATION OF LAW FOR ANY PERSON, UNLESS THEY ARE ACTING UNDER THE DIRECTION OF A LICENSED PROFESSIONAL ENGINEER, TO ALTER THIS DOCUMENT.

SHANNON PARK
SOH3625
6790 COFFMAN RD
DUBLIN, OH 43017
COLOCATION

SHEET TITLE
GROUNDING SITE PLAN
AND NOTES

SHEET NUMBER
G-1

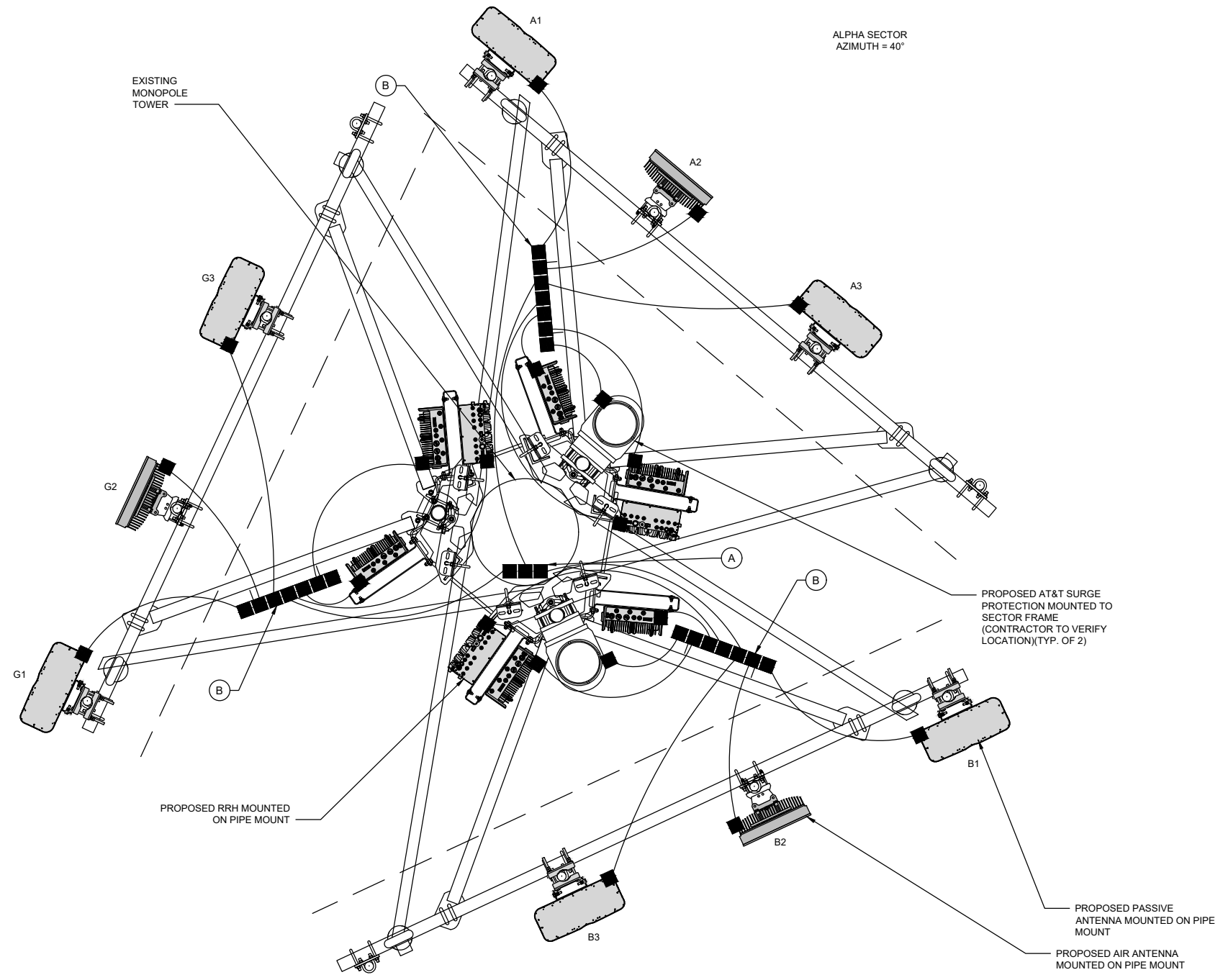

ALPHA SECTOR
AZIMUTH = 40°

GAMMA SECTOR
AZIMUTH = 295°

BETA SECTOR
AZIMUTH = 155°



1. GROUNDING IS SHOWN DIAGRAMMATICALLY ONLY.
2. CONTRACTOR SHALL HAVE A COMPLETE UNDERSTANDING OF THE CONTENTS OF AT&T STANDARD TP-76416.
3. ALL INSTALLATIONS SHALL BE FIELD VERIFIED.
4. TOWER GROUNDING BAR: EXTEND (2) #2 AWG TINNED CU WIRE FROM BURIED GROUND RING UP TO THE TOWER GROUND BAR AND MAKE A MECHANICAL CONNECTION. SECURE GROUND BAR DIRECTLY TO TOWER WITH STAINLESS STEEL MOUNTING MATERIAL.
5. ANTENNA GROUNDING BAR: ANDREW CORPORATION PART #UGBKIT-0424-T MOUNT GROUND BAR DIRECTLY TO TOWER. SECURE TO TOWER WITH STAINLESS STEEL MOUNTING MATERIAL.
6. GROUNDING BAR: LOCATED CLOSE TO GRADE LOCK BOX TESSCO PART #351546: INSTALL PER MANUFACTURER GUIDELINES.
7. EXOTHERMIC OR COMPRESSION CONNECTION FOR PIPE MOUNT TO ANTENNA ROUTE CONDUCTOR TO NEAREST GROUNDING BAR SO THE GROUNDING CONDUCTORS PROVIDE A STRAIGHT DOWNWARD PATH TO GROUND. USE #2 AWG SOLID TINNED COPPER CONDUCTOR. GROUNDING CONNECTION SHALL BE LOCATED AT THE TOP 2" OF PIPE.
8. ALL GROUNDING CONDUCTORS SHALL BE #2 AWG COPPER TINNED UNLESS NOTED OTHERWISE.
9. ALL GROUNDING CONDUCTORS SHALL PROVIDE A STRAIGHT DOWNWARD PATH TO GROUND WITH GRADUAL BEND AS REQUIRED. GROUND WIRES SHALL NOT BE LOOPED OR SHARPLY BENT.
10. KOPR-SHIELD ANTI-OXIDATION COMPOUND SHALL BE USED ON ALL COMPRESSION GROUNDING CONNECTIONS.
11. ALL EXOTHERMIC CONNECTIONS SHALL BE INSTALLED UTILIZING THE PROPER CONNECTION/MOLD AND MATERIALS FOR THE PARTICULAR APPLICATION.
12. ALL BOLTED GROUNDING CONNECTIONS SHALL BE INSTALLED WITH AN EXTERNAL TOOTHED LOCK WASHER. GROUNDING BUS BARS MAY HAVE PRE-PUNCHED HOLES OR TAPPED HOLES. ALL HARDWARE SHALL BE SECURITY TORQUE HARDWARE 3/8" STAINLESS STEEL.
13. EXTERNAL GROUNDING CONDUCTOR SHALL NOT BE INSTALLED OR ROUTED THROUGH HOLES IN ANY METAL OBJECTS, CONDUITS, OR SUPPORTS TO PRECLUDE ESTABLISHING A MAGNETIC CHOKE POINT.
14. PLASTIC CLIPS SHALL BE USED TO FASTEN AND SUPPORT GROUNDING CONDUCTORS. FERROUS METAL CLIPS WHICH COMPLETELY SURROUND THE GROUNDING CONDUCTOR SHALL NOT BE USED.
15. IF COAX ON ICE BRIDGE IS MORE THAT 6' FROM THE GROUND BAR AT THE BASE OF THE TOWER, A SECOND GROUND BAR WILL BE NEEDED AT THE END OF THE ICE BRIDGE RUN TO GROUND THE COAX GROUND KIT AND THE IN-LINE SURGE ARRESTORS (SURGE ARRESTORS INSTALLED BY LUCENT ONLY HAVE 6' GROUND TAILS).
16. CONTRACTOR SHALL REPAIR/PLACE EXISTING GROUNDING SYSTEM COMPONENTS DAMAGED DURING CONSTRUCTION AT THE CONTRACTORS EXPENSE.

NOTES	2
--------------	----------

- (A) TOWER TOP GROUNDING BAR: MECHANICALLY BOND GROUND BAR TO STRUCTURE.
- (B) ANTENNA GROUND BAR: #2 AWG SOLID TINNED COPPER BOND TO TOWER TOP GROUND BAR.

KEY NOTES	3
------------------	----------

- EXOTHERMIC TYPE CONNECTION
- COMPRESSION TYPE CONNECTION
- GROUNDING CONDUCTOR
- GROUNDING BAR

LEGEND	4
---------------	----------

188 INVERNESS DRIVE WEST
SUITE 400
ENGLEWOOD, CO 80112

6615 TOWPATH ROAD
EAST SYRACUSE, NY 13057

520 South Main Street, Suite 2531
Akron, OH 44311
330.572.2100 Fax 330.572.2101
Copyright: Glau, Pyle, Schomer, Burns & DeHaven, Inc. 2025

GPD JOB #:	2025705.79
DRAWN BY:	ACM
CHECKED BY:	LJB
RFDS:	25309

REV	DATE	DESCRIPTION
0	08/27/2025	FOR CONSTRUCTION
C	08/15/2025	REV. PER COMMENTS
B	08/12/2025	REV. PER COMMENTS
A	06/05/2025	ISSUED FOR REVIEW

STEVEN P. SCHAUB
E -76700
08/27/2025

IT IS A VIOLATION OF LAW FOR ANY PERSON, UNLESS THEY ARE ACTING UNDER THE DIRECTION OF A LICENSED PROFESSIONAL ENGINEER, TO ALTER THIS DOCUMENT.

SHANNON PARK
50H3625
6790 COFFMAN RD
DUBLIN, OH 43017
COLOCATION

SHEET TITLE
ANTENNA GROUNDING PLAN

SHEET NUMBER
G-2

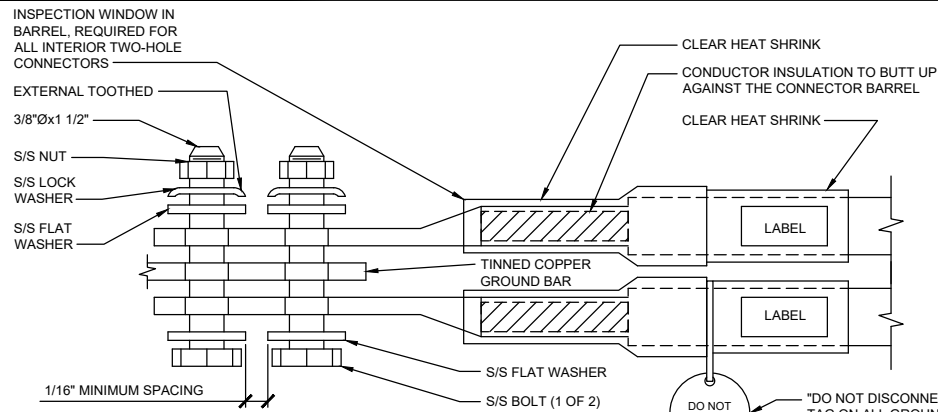

NOTES:

- EXOTHERMIC WELD (2) TWO, #2 AWG BARE TINNED SOLID COPPER CONDUCTORS TO GROUND BAR. ROUTE CONDUCTORS TO BURIED GROUND RING AND PROVIDE PARALLEL EXOTHERMIC WELD.
- ALL GROUND BARS SHALL BE STAMPED IN TO THE METAL "IF STOLEN DO NOT RECYCLE." THE CONTRACTOR SHALL USE PERMANENT MARKER TO DRAW THE LINES BETWEEN EACH SECTION AND LABEL EACH SECTION ("P", "A", "N", "I") WITH 1" HIGH LETTERS.
- ALL HARDWARE SHALL BE STAINLESS STEEL 3/8" DIAMETER OR LARGER. ALL HARDWARE 18-8 STAINLESS STEEL INCLUDING LOCK WASHERS, COAT ALL SURFACES WITH AN ANTI-OXIDANT COMPOUND BEFORE MATING.
- FOR GROUND BOND TO STEEL ONLY: INSERT A CADMIUM FLAT WASHER BETWEEN LUG AND STEEL, COAT ALL SURFACES WITH AN ANTI-OXIDANT COMPOUND BEFORE MATING.
- DO NOT INSTALL CABLE GROUND KIT AT A BEND AND ALWAYS DIRECT GROUND CONDUCTOR DOWN TO GROUND BUS.
- NUT & WASHER SHALL BE PLACED ON THE FRONT SIDE OF THE GROUND BAR AND BOLTED ON THE BACK SIDE. INSTALL BLACK HEAT-SHRINKING TUBE, 600 VOLT INSULATION, ON ALL GROUND TERMINATIONS. THE INTENT IS TO WEATHERPROOF THE COMPRESSION CONNECTION.
- SUPPLIED AND INSTALLED BY CONTRACTOR.
- THE CONTRACTOR SHALL BE RESPONSIBLE FOR INSTALLING ADDITIONAL GROUND BAR AS REQUIRED, PROVIDING 50% SPARE CONNECTION POINTS.
- ENSURE THE WIRE INSULATION TERMINATION IS WITHIN 1/8" OF THE BARREL (NO SHINERS).
- BOLTS SHALL BE MADE "SNUG-TIGHT" PLUS 1/4 TURN.

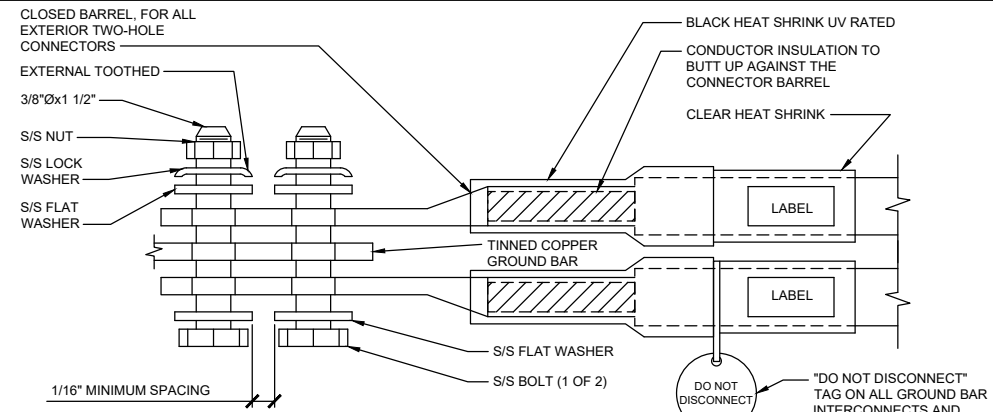

NOTES:

- EXOTHERMIC WELD (2) TWO, #2 AWG BARE TINNED SOLID COPPER CONDUCTORS TO GROUND BAR. ROUTE CONDUCTORS TO BURIED GROUND RING AND PROVIDE PARALLEL EXOTHERMIC WELD.
- ALL GROUND BARS SHALL BE STAMPED IN TO THE METAL "IF STOLEN DO NOT RECYCLE." THE CONTRACTOR SHALL USE PERMANENT MARKER TO DRAW THE LINES BETWEEN EACH SECTION AND LABEL EACH SECTION ("P", "A", "N", "I") WITH 1" HIGH LETTERS.
- ALL HARDWARE SHALL BE STAINLESS STEEL 3/8" DIAMETER OR LARGER. ALL HARDWARE 18-8 STAINLESS STEEL INCLUDING LOCK WASHERS, COAT ALL SURFACES WITH AN ANTI-OXIDANT COMPOUND BEFORE MATING.
- FOR GROUND BOND TO STEEL ONLY: INSERT A CADMIUM FLAT WASHER BETWEEN LUG AND STEEL, COAT ALL SURFACES WITH AN ANTI-OXIDANT COMPOUND BEFORE MATING.
- DO NOT INSTALL CABLE GROUND KIT AT A BEND AND ALWAYS DIRECT GROUND CONDUCTOR DOWN TO GROUND BUS.
- NUT & WASHER SHALL BE PLACED ON THE FRONT SIDE OF THE GROUND BAR AND BOLTED ON THE BACK SIDE. INSTALL BLACK HEAT-SHRINKING TUBE, 600 VOLT INSULATION, ON ALL GROUND TERMINATIONS. THE INTENT IS TO WEATHERPROOF THE COMPRESSION CONNECTION.
- SUPPLIED AND INSTALLED BY CONTRACTOR.
- THE CONTRACTOR SHALL BE RESPONSIBLE FOR INSTALLING ADDITIONAL GROUND BAR AS REQUIRED, PROVIDING 50% SPARE CONNECTION POINTS.
- ENSURE THE WIRE INSULATION TERMINATION IS WITHIN 1/8" OF THE BARREL (NO SHINERS).
- BOLTS SHALL BE MADE "SNUG-TIGHT" PLUS 1/4 TURN.

INTERIOR TWO HOLE LUG DETAIL

NO SCALE

1

EXTERIOR TWO HOLE LUG DETAIL

NO SCALE

2

NEWTON INSTRUMENT COMPANY, INC.
BUTNER, N.C.

NO	REQUIRED	PART NUMBER	DESCRIPTION
1	1	1/4"x4"x30"	SOLID GROUND BAR
2	2	A-6056	WALL MOUNTING BRACKET
3	2	3061-4	INSULATORS
4	4	3012-1	5/8"-11x1" H.H.C.S.
5	4	3015-8	5/8" LOCKWASHER

EACH GROUND CONDUCTOR TERMINATING ON ANY GROUND BAR SHALL HAVE AN IDENTIFICATION TAG ATTACHED AT EACH END THAT WILL IDENTIFY ITS ORIGIN AND DESTINATION

SECTION "P" - SURGE PROTECTORS

- (EC) CELL REFERENCE GROUND BAR (IF COLLOCATED)
- (EC) GENERATOR FRAMEWORK (IF AVAILABLE) (#2 AWG)
- (EC) TELCO GROUND BAR (#2 AWG)
- (EC) COMMERCIAL POWER COMMON NEUTRAL/GROUND BOND (3/0)
- (EC) FIBER GROUND BAR (#2 AWG)
- (EC) POWER ROOM REFERENCE GROUND BAR (#2 AWG)
- (AT&T) RECTIFIER FRAMES

SECTION "A" - SURGE ABSORBERS

- (EC) INTERIOR GROUND RING (#2 AWG)
- (EC) EXTERNAL EARTH GROUND FIELD (BURIED GROUND RING) (#2 AWG)
- (EC) METALLIC COLD WATER PIPE (IF AVAILABLE) (1/0 AWG)
- (EC) BUILDING STEEL (IF AVAILABLE) (1/0 AWG)

SECTION "I" - ISOLATED GROUND ZONE

- (AT&T) ALL ISOLATED GROUND REFERENCE
- (AT&T) GROUND WINDOW BAR

DETAIL NOTES:

- EXOTHERMICALLY WELD #2 AWG BARE TINNED SOLID COPPER CONDUCTOR TO GROUND BAR. ROUTE CONDUCTOR TO BURIED GROUND RING AND PROVIDE PARALLEL EXOTHERMIC WELD.
- THE INSTALLER SHALL USE PERMANENT MARKER TO DRAW THE LIKE BETWEEN SECTION AND LABEL EACH SECTION ("P", "A", "I") WITH 1" HIGH LETTERS

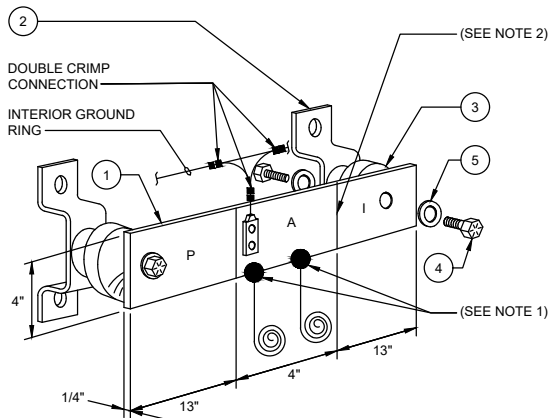

(MGB) REFERENCE GROUNDING BAR DETAIL

NO SCALE

3

NOT USED

NO SCALE

4

GROUNDING BAR DETAIL

NO SCALE

5

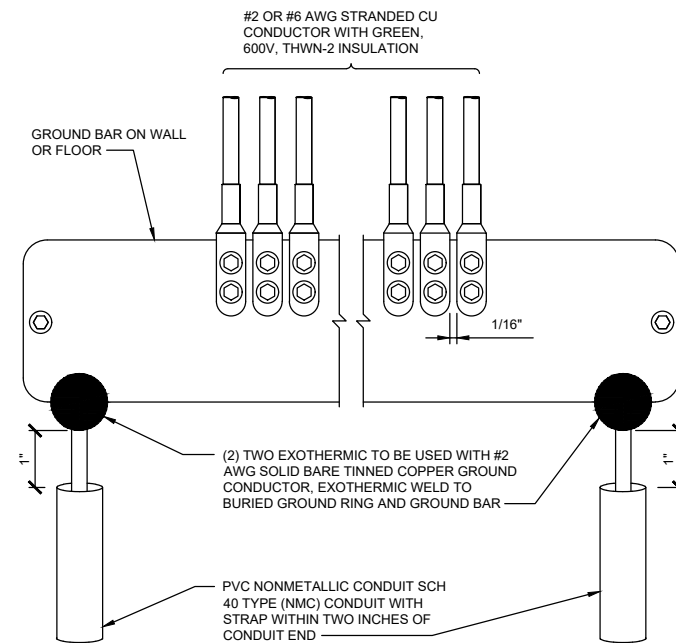

188 INVERNESS DRIVE WEST
SUITE 400
ENGLEWOOD, CO 80112

6615 TOWPATH ROAD
EAST SYRACUSE, NY 13057

520 South Main Street, Suite 2531
Akron, OH 44311
330.572.2100 Fax 330.572.2101
Copyright: Glauz, Pyle, Schomer, Burns & DeHaven, Inc. 2025

GPD JOB #: 2025705.79

DRAWN BY: ACM

CHECKED BY: LJB

RFDS: 25309

REV	DATE	DESCRIPTION
0	08/27/2025	FOR CONSTRUCTION
C	08/15/2025	REV. PER COMMENTS
B	08/12/2025	REV. PER COMMENTS
A	06/05/2025	ISSUED FOR REVIEW

IT IS A VIOLATION OF LAW FOR ANY PERSON, UNLESS THEY ARE ACTING UNDER THE DIRECTION OF A LICENSED PROFESSIONAL ENGINEER, TO ALTER THIS DOCUMENT.

SHANNON PARK
SOH3625
6790 COFFMAN RD
DUBLIN, OH 43017
COLOCATION

SHEET TITLE
GROUNDING DETAILS

SHEET NUMBER
G-3



DETAIL NOT USED

NO SCALE

1



DETAIL NOT USED

NO SCALE

2

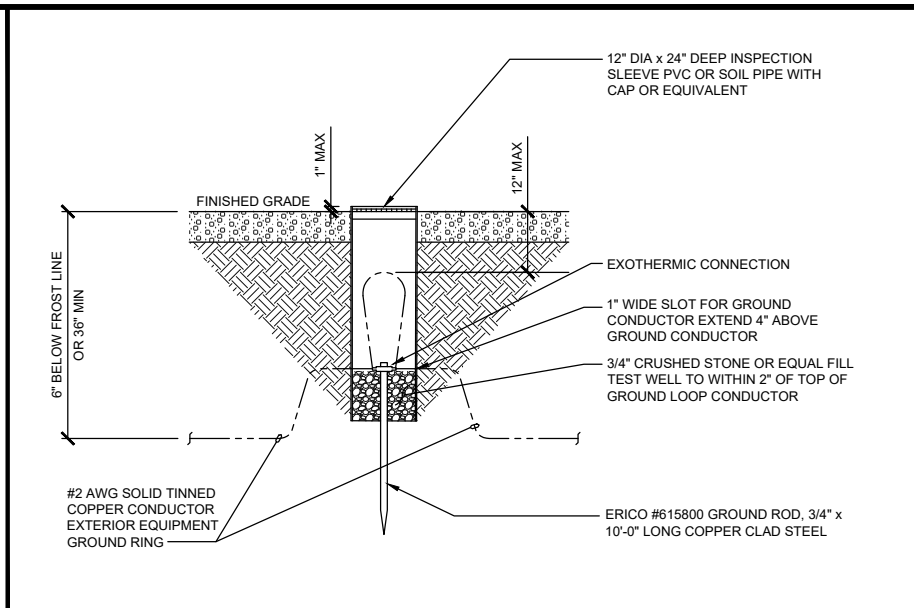

TEST GROUND ROD WITH INSPECTION SLEEVE DETAIL

NO SCALE

3

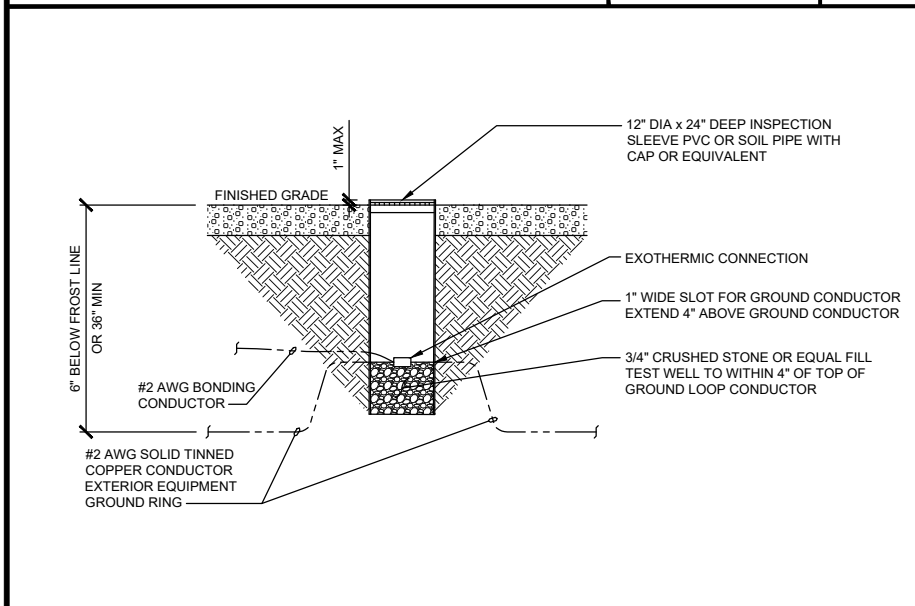

EXOTHERMIC WITH INSPECTION SLEEVE DETAIL

NO SCALE

4

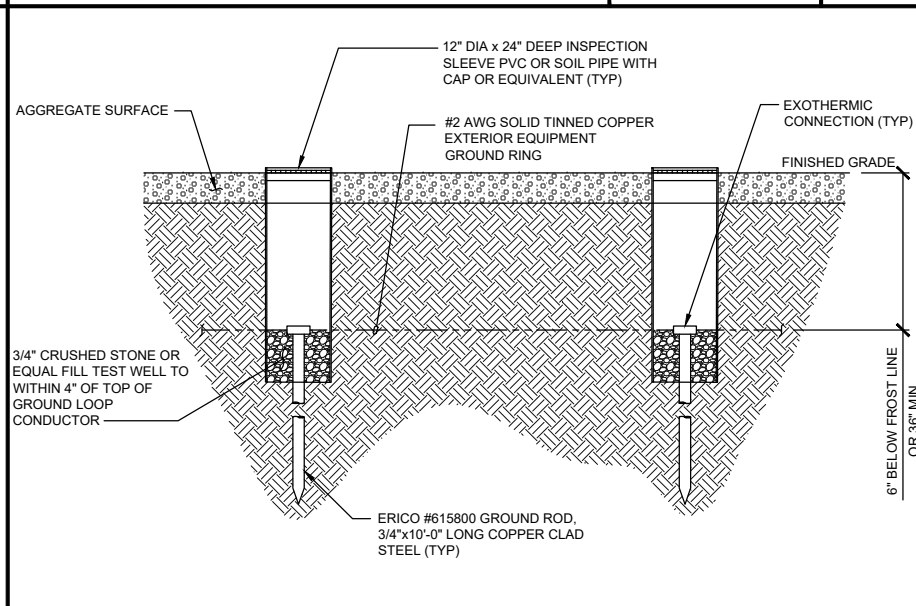

GROUNDING ROD WITH INSPECTION SLEEVE DETAIL

NO SCALE

5

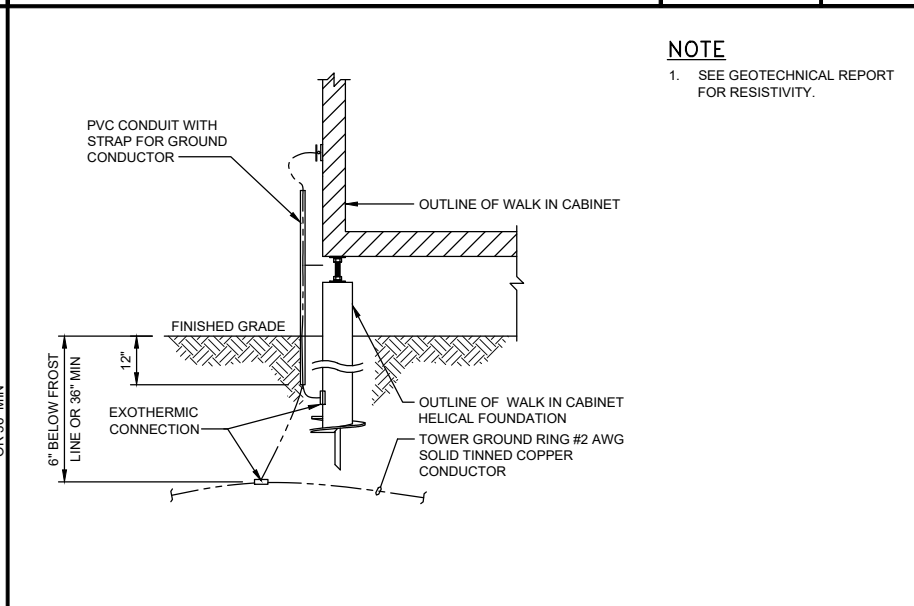

CABINET GROUNDING DETAIL

NO SCALE

6

NOTE

1. SEE GEOTECHNICAL REPORT FOR RESISTIVITY.

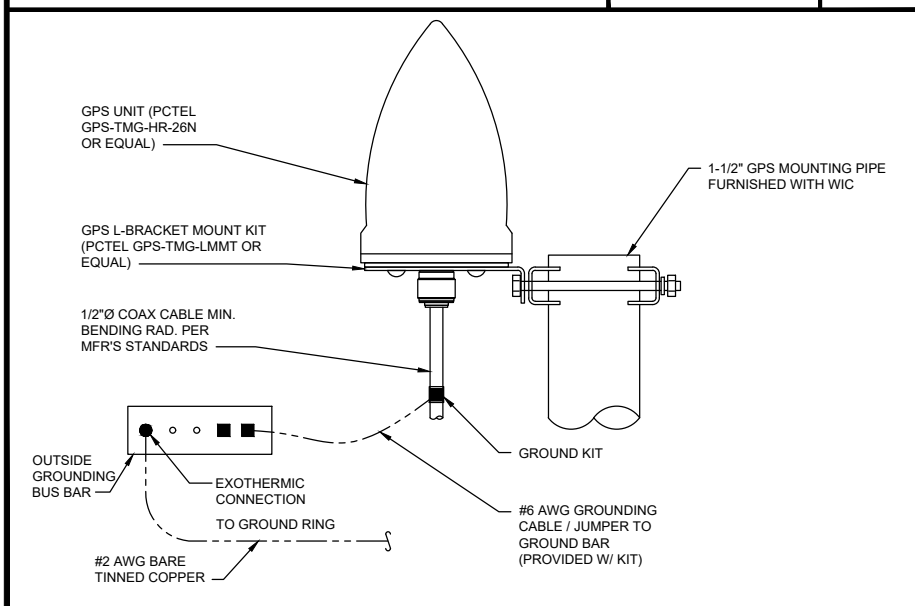

GPS ANTENNA GROUNDING DETAIL

NO SCALE

7

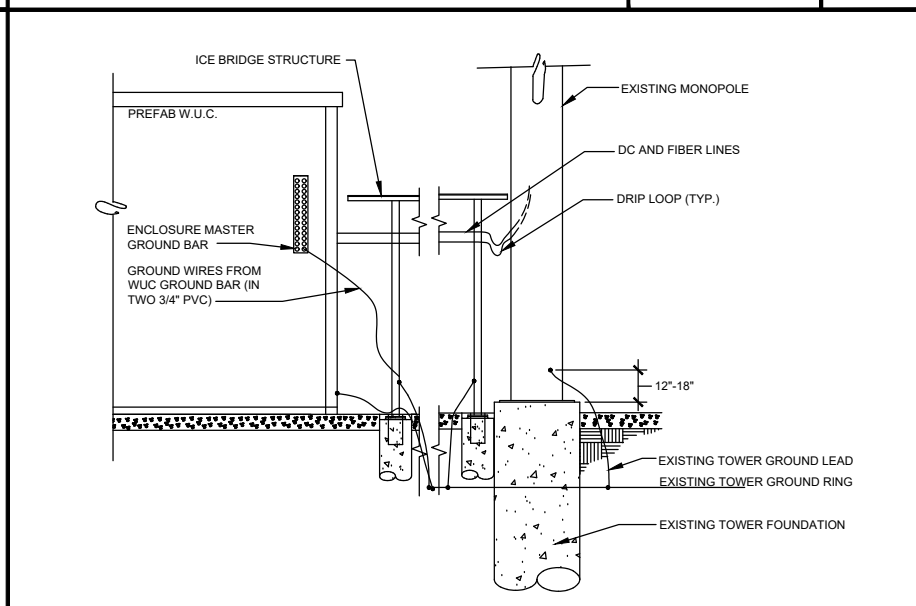

ICE BRIDGE AND ANTENNA CABLE DETAIL

NO SCALE

8

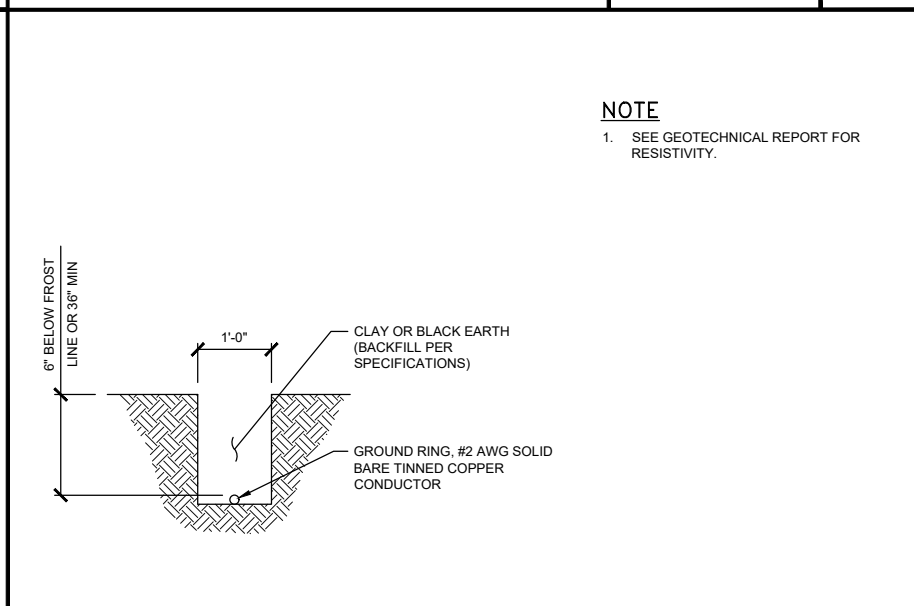

GROUNDING RING TRENCH DETAIL

NO SCALE

9

NOTE

1. SEE GEOTECHNICAL REPORT FOR RESISTIVITY.

188 INVERNESS DRIVE WEST
SUITE 400
ENGLEWOOD, CO 80112

6615 TOWPATH ROAD
EAST SYRACUSE, NY 13057

520 South Main Street, Suite 2531
Akron, OH 44311
330.572.2100 Fax 330.572.2101
Copyright: Glau, Pyle, Schomer, Burns & DeHaven, Inc. 2025

GPD JOB #: 2025705.79

DRAWN BY: ACM

CHECKED BY: LJB

RFDS: 25309

REV	DATE	DESCRIPTION
0	08/27/2025	FOR CONSTRUCTION
C	08/15/2025	REV. PER COMMENTS
B	08/12/2025	REV. PER COMMENTS
A	06/05/2025	ISSUED FOR REVIEW

SHANNON PARK
SOH3625
6790 COFFMAN RD
DUBLIN, OH 43017
COLOCATION

SHEET TITLE
GROUNDING DETAILS

SHEET NUMBER
G-4

PART 1 - GENERAL

1.1 GENERAL CONDITIONS:

- A. CONTRACTOR SHALL INSPECT THE EXISTING SITE CONDITIONS PRIOR TO SUBMITTING BID. ANY QUESTIONS ARISING DURING THE BID PERIOD IN REGARDS TO THE CONTRACTORS FUNCTIONS, THE SCOPE OF WORK, OR ANY OTHER ISSUE RELATED TO THIS PROJECT SHALL BE BROUGHT UP DURING THE BID PERIOD WITH THE PROJECT MANAGER FOR CLARIFICATION, NOT AFTER THE CONTRACT HAS BEEN AWARDED.
B. THE CONTRACTOR SHALL OBTAIN PERMITS, LICENSES, MAKE ALL DEPOSITS, AND PAY ALL FEES REQUIRED FOR THE CONSTRUCTION PERFORMANCE FOR THE WORK UNDER THIS SECTION.
C. DRAWINGS SHOW THE GENERAL ARRANGEMENT OF ALL SYSTEMS AND COMPONENTS COVERED UNDER THIS SECTION. THE CONTRACTOR SHALL VERIFY ALL DIMENSIONS. DRAWING SHALL NOT BE SCALED TO DETERMINE DIMENSIONS.

1.2 LAWS, REGULATIONS, ORDINANCES, STATUTES AND CODES.

- A. ALL WORK SHALL BE INSTALLED IN ACCORDANCE WITH THE LATEST EDITION OF THE NATIONAL ELECTRICAL CODE, AND ALL APPLICABLE LOCAL LAWS, REGULATIONS, ORDINANCES, STATUTES AND CODES. CONDUIT BENDS SHALL BE THE RADIUS BEND FOR THE TRADE SIZE OF CONDUIT IN COMPLIANCE WITH THE LATEST EDITIONS OF NEC.

1.3 REFERENCES:

- A. THE PUBLICATIONS LISTED BELOW ARE PART OF THIS SPECIFICATION. EACH PUBLICATION SHALL BE THE LATEST REVISION AND ADDENDUM IN EFFECT ON THE DATE. THIS SPECIFICATION IS ISSUED FOR CONSTRUCTION UNLESS OTHERWISE NOTED. EXCEPT AS MODIFIED BY THE REQUIREMENT SPECIFIED HEREIN OR THE DETAILS OF THE DRAWINGS, WORK INCLUDED IN THIS SPECIFICATION SHALL CONFORM TO THE APPLICABLE PROVISION OF THESE PUBLICATIONS.

- 1. ANS/IEEE (AMERICAN NATIONAL STANDARDS INSTITUTE)
2. ASTM (AMERICAN SOCIETY FOR TESTING AND MATERIALS)
3. ICEA (INSULATED CABLE ENGINEERS ASSOCIATION)
4. NEMA (NATIONAL ELECTRICAL MANUFACTURER'S ASSOCIATION)
5. NFPA (NATIONAL FIRE PROTECTION ASSOCIATION)
6. OSHA (OCCUPATIONAL SAFETY AND HEALTH ADMINISTRATION)
7. UL (UNDERWRITERS LABORATORIES INC.)
8. AT&T GROUNDING AND BONDING STANDARDS TP-76416

1.4 SCOPE OF WORK

- A. WORK UNDER THIS SECTION SHALL CONSIST OF FURNISHING ALL LABOR, MATERIAL, AND ASSOCIATED SERVICES REQUIRED TO COMPLETE REQUIRED CONSTRUCTION AND BE OPERATIONAL.
B. ALL ELECTRICAL EQUIPMENT UNDER THIS CONTRACT SHALL BE PROPERLY TESTED, ADJUSTED, AND ALIGNED BY THE CONTRACTOR.
C. THE CONTRACTOR SHALL BE RESPONSIBLE FOR ALL EXCAVATING, DRAINING, TRENCHES, BACKFILLING, AND REMOVAL OF EXCESS DIRT.
D. THE CONTRACTOR SHALL FURNISH TO THE OWNER WITH CERTIFICATES OF A FINAL INSPECTION AND APPROVAL FROM THE INSPECTION AUTHORITIES HAVING JURISDICTION.
E. THE CONTRACTOR SHALL PREPARE A COMPLETE SET OF AS-BUILT DRAWINGS, DOCUMENT ALL WIRING EQUIPMENT CONDITIONS, AND CHANGES WHILE COMPLETING THIS CONTRACT. THE AS-BUILT DRAWINGS SHALL BE SUBMITTED AT COMPLETION OF THE PROJECT.

PART 2 - PRODUCTS

2.1 GENERAL:

- A. ALL MATERIALS AND EQUIPMENT SHALL BE UL LISTED, NEW, AND FREE FROM DEFECTS.
B. ALL ITEMS OF MATERIALS AND EQUIPMENT SHALL BE ACCEPTABLE TO THE AUTHORITY HAVING JURISDICTION AS SUITABLE FOR THE USE INTENDED.
C. ALL EQUIPMENT SHALL BEAR THE UNDERWRITERS LABORATORIES LABEL OF APPROVAL, AND SHALL CONFORM TO REQUIREMENT OF THE NATIONAL ELECTRICAL CODE.
D. ALL OVERCURRENT DEVICES SHALL HAVE AN INTERRUPTING CURRENT RATING THAT SHALL BE GREATER THAN THE SHORT CIRCUIT CURRENT TO WHICH THEY ARE SUBJECTED, 10,000 AIC MINIMUM. VERIFY AVAILABLE SHORT CIRCUIT CURRENT DOES NOT EXCEED THE RATING OF ELECTRICAL EQUIPMENT IN ACCORDANCE WITH ARTICLE 110.24 NEC OR THE MOST CURRENT ADOPTED CODE PER THE GOVERNING JURISDICTION.

2.2 MATERIALS AND EQUIPMENT:

- A. CONDUIT:
1. RIGID METAL CONDUIT (RMC) SHALL BE HOT-DIPPED GALVANIZED INSIDE AND OUTSIDE INCLUDING ENDS AND THREADS AND ENAMELED OR LACQUERED INSIDE IN ADDITION TO GALVANIZING.
2. LIQUIDTIGHT FLEXIBLE METAL CONDUIT SHALL BE UL LISTED.
3. CONDUIT CLAMPS, STRAPS AND SUPPORTS SHALL BE STEEL OR MALLEABLE IRON. ALL FITTINGS SHALL BE COMPRESSION AND CONCRETE TIGHT TYPE. GROUNDING BUSHINGS WITH INSULATED THROATS SHALL BE INSTALLED ON ALL CONDUIT TERMINATIONS.
4. NONMETALLIC CONDUIT AND FITTINGS SHALL BE SCHEDULE 40 PVC. INSTALL USING SOLVENT-CEMENT-TYPE JOINTS AS RECOMMENDED BY THE MANUFACTURER.
B. CONDUCTORS AND CABLE:
1. CONDUCTORS AND CABLE SHALL BE FLAME-RETARDANT, MOISTURE AND HEAT RESISTANT THERMOPLASTIC, SINGLE CONDUCTOR, COPPER, TYPE THHN/THWN-2, 600 VOLT, SIZE AS INDICATED, #12 AWG SHALL BE THE MINIMUM SIZE CONDUCTOR USED.
2. #10 AWG AND SMALLER CONDUCTOR SHALL BE SOLID OR STRANDED AND #8 AWG AND LARGER CONDUCTORS SHALL BE STRANDED.
3. SOLDERLESS, COMPRESSION-TYPE CONNECTORS SHALL BE USED FOR TERMINATION OF ALL STRANDED CONDUCTORS.
4. STRAIN-RELIEF SUPPORTS GRIPS SHALL BE HUBBELL KELLEMS OR APPROVED EQUAL. CABLES SHALL BE SUPPORTED IN ACCORDANCE WITH THE NEC AND CABLE MANUFACTURER'S RECOMMENDATIONS.
5. ALL CONDUCTORS SHALL BE TAGGED AT BOTH ENDS OF THE CONDUCTOR, AT ALL PULL BOXES, J-BOXES, EQUIPMENT AND CABINETS AND SHALL BE IDENTIFIED WITH APPROVED PLASTIC TAGS (ACTION CRAFT, BRADY, OR APPROVED EQUAL).
C. DISCONNECT SWITCHES:
1. DISCONNECT SWITCHES SHALL BE HEAVY DUTY, DEAD-FRONT, QUICK-MAKE, QUICK-BREAK, EXTERNALLY OPERABLE, HANDLE LOCKABLE AND INTERLOCK WITH COVER IN CLOSED POSITION, RATING AS INDICATED, UL LABELED FURNISHED IN NEMA 3R ENCLOSURE, PROVIDE IF SHOWN ON PLANTS, SQUARE-D OR ENGINEER APPROVED EQUAL.
D. CHEMICAL ELECTROLYTIC GROUNDING SYSTEM: PROVIDE ONLY IF SHOWN ON DRAWINGS
1. INSTALL CHEMICAL GROUNDING AS REQUIRED. THE SYSTEM SHALL BE ELECTROLYTIC MAINTENANCE FREE ELECTRODE CONSISTING OF RODS WITH A MINIMUM #2 AWG CU EXOTHERMICALLY WELDED PIGTAIL, PROTECTIVE BOXES, AND BACKFILL MATERIAL. MANUFACTURER SHALL BE LYNCOLE XIT GROUNDING ROD TYPES K2-(*)CS OR K2L-(*)CS (*) LENGTH AS REQUIRED.
2. GROUND ACCESS BOX SHALL BE A POLYPLASTIC BOX FOR NON-TRAFFIC APPLICATIONS, INCLUDING BOLT DOWN FLUSH COVER WITH "BREATHING" HOLES, XIT MODEL #XB-22. ALL DISCONNECT SWITCHES AND CONTROLLING DEVICES SHALL BE PROVIDED WITH ENGRAVED LAMICOID NAMEPLATES INDICATING EQUIPMENT CONTROLLED, BRANCH CIRCUITS ID

NUMBERING, AND THE ELECTRICAL POWER SOURCE.

3. BACKFILL MATERIAL SHALL BE LYNCONITE AND LYNCOLE GROUNDING GRAVEL.

E. SYSTEM GROUNDING:

- 1. ALL GROUNDING COMPONENTS SHALL BE TINNED AND GROUNDING CONDUCTOR SHALL BE #2 AWG BARE, SOLID, TINNED, COPPER. ABOVE GRADE GROUNDING CONDUCTORS SHALL BE INSULATED WHERE NOTED.
2. GROUNDING BUSES SHALL BE BARE, TINNED, ANNEALED COPPER BARS OF RECTANGULAR CROSS SECTION. STANDARD BUS BARS MGB, SHALL BE FURNISHED AND INSTALLED BY THE CONTRACTOR. THEY SHALL NOT BE FABRICATED OR MODIFIED IN THE FIELD. ALL GROUNDING BUSES SHALL BE IDENTIFIED WITH MINIMUM 3/4" LETTERS BY WAY OF STENCILING OR DESIGNATION PLATE.
3. CONNECTORS SHALL BE HIGH-CONDUCTIVITY, HEAVY DUTY, LISTED AND LABELED AS GROUNDING CONNECTORS FOR THE MATERIALS USED. USE TWO-HOLE COMPRESSION LUGS WITH HEAT SHRINK FOR MECHANICAL CONNECTIONS. INTERIOR CONNECTIONS USE TWO-HOLE COMPRESSION LUGS WITH INSPECTION WINDOW AND CLEAR HEAT SHRINK.
4. EXOTHERMIC WELDED CONNECTIONS SHALL BE PROVIDED IN KIT FORM AND SELECTED FOR THE SPECIFIC TYPES, SIZES, AND COMBINATIONS OF CONDUCTORS AND OTHER ITEMS TO BE CONNECTED.
5. GROUND RODS SHALL BE COPPER-CLAD STEEL WITH HIGH-STRENGTH STEEL CORE AND ELECTROLYTIC-GRADE COPPER OUTER SHEATH, MOLTEN WELDED TO CORE, 5/8"x10'-0". ALL GROUNDING RODS SHALL BE INSTALLED WITH INSPECTION SLEEVES.
6. INSTALL AN EQUIPMENT GROUNDING CONDUCTOR IN ALL CONDUITS IN COMPLIANCE WITH THE AT&T SPECIFICATIONS AND NEC. THE EQUIPMENT GROUNDING CONDUCTORS SHALL BE BONDED AT ALL JUNCTION BOXES, PULLBOXES, DISCONNECT SWITCHES, STARTERS, AND EQUIPMENT CABINETS.

F. OTHER MATERIALS:

- 1. THE CONTRACTOR SHALL PROVIDE OTHER MATERIALS, THOUGH NOT SPECIFICALLY DESCRIBED, WHICH ARE REQUIRED FOR A COMPLETELY OPERATIONAL SYSTEM AND PROPER INSTALLATION OF THE WORK.
2. PROVIDE PULL BOXES AND JUNCTION BOXES WHERE SHOWN OR REQUIRED BY NEC.

G. PANELS AND LOAD CENTERS:

- 1. ALL PANEL DIRECTORIES SHALL BE TYPEWRITTEN.

PART 3 - EXECUTION

3.1 GENERAL:

- A. ALL MATERIAL AND EQUIPMENT SHALL BE INSTALLED IN STRICT ACCORDANCE WITH THE MANUFACTURER'S RECOMMENDATIONS.
B. EQUIPMENT SHALL BE TIGHTLY COVERED AND PROTECTED AGAINST DIRT OR WATER, AND AGAINST CHEMICAL OR MECHANICAL INJURY DURING INSTALLATION AND CONSTRUCTION PERIODS.
3.2 LABOR AND WORKMANSHIP:
A. ALL LABOR FOR THE INSTALLATION OF MATERIALS AND EQUIPMENT FURNISHED FOR THE ELECTRICAL SYSTEM SHALL BE INSTALLED BY EXPERIENCED WIREMEN, IN A NEAT AND WORKMAN-LIKE MANNER.
B. ALL ELECTRICAL EQUIPMENT SHALL BE ADJUSTED, ALIGNED AND TESTED BY THE CONTRACTOR AS REQUIRED TO PRODUCE THE INTENDED PERFORMANCE.
C. UPON COMPLETION OF WORK, THE CONTRACTOR SHALL THOROUGHLY CLEAN ALL EXPOSED EQUIPMENT, REMOVE ALL LABELS AND ANY DEBRIS, CRATING OR CARTONS AND LEAVE THE INSTALLATION FINISHED AND READY FOR OPERATION.

3.3 COORDINATION:

- A. THE CONTRACTOR SHALL COORDINATE THE INSTALLATION OF ELECTRICAL ITEMS WITH THE OWNER-FURNISHED EQUIPMENT DELIVERY SCHEDULE TO PREVENT UNNECESSARY DELAYS IN THE TOTAL WORK.

3.4 INSTALLATION:

- A. CONDUIT:
1. ALL ELECTRICAL WIRING SHALL BE INSTALLED IN CONDUIT AS SPECIFIED. NO CONDUIT OR TUBING OF LESS THAN 3/4 INCH TRADE SIZE.
2. PROVIDE RIGID PVC SCHEDULE 80 CONDUITS FOR ALL RISERS, RMC OTHERWISE NOTED. EMT MAY BE INSTALLED FOR EXTERIOR CONDUITS WHERE NOT SUBJECT TO PHYSICAL DAMAGE.
3. INSTALL SCHEDULE 40 PVC CONDUIT WITH A MINIMUM COVER OF 24" UNDER ROADWAYS, PARKING LOTS, STREETS, AND ALLEYS. CONDUIT SHALL HAVE A MINIMUM COVER OF 18" IN ALL OTHER NON-TRAFFIC APPLICATIONS.
4. USE GALVANIZED FLEXIBLE STEEL CONDUIT WHERE DIRECT CONNECTION TO EQUIPMENT WITH MOVEMENT, VIBRATION, OR FOR EASE OF MAINTENANCE. USE LIQUID TIGHT, FLEXIBLE METAL CONDUIT FOR OUTDOOR APPLICATIONS. INSTALL GALVANIZED FLEXIBLE STEEL CONDUIT AT ALL POINTS OF CONNECTION TO EQUIPMENT MOUNTED ON SUPPORT TO ALLOW FOR EXPANSION AND CONTRACTION.
5. A RUN OF CONDUIT BETWEEN BOXES OR EQUIPMENT SHALL NOT CONTAIN MORE THAN THE EQUIVALENT OF THREE QUARTER-BENDS. CONDUIT BEND SHALL BE MADE WITH THE UL LISTED BENDER OR FACTORY 90 DEGREE ELBOWS MAY BE USED.
6. FIELD FABRICATED CONDUITS SHALL BE CUT SQUARE WITH A CONDUIT CUTTING TOOL AND REAMED TO PROVIDE A SMOOTH INSIDE SURFACE.
7. PROVIDE INSULATED GROUNDING BUSHING FOR ALL CONDUITS.
8. CONTRACTOR IS RESPONSIBLE FOR PROTECTING ALL CONDUITS DURING CONSTRUCTION. TEMPORARY OPENINGS IN THE CONDUIT SYSTEM SHALL BE PLUGGED OR CAPPED TO PREVENT ENTRANCE OF MOISTURE OR FOREIGN MATTER. CONTRACTOR SHALL REPLACE ANY CONDUITS CONTAINING FOREIGN MATERIALS THAT CANNOT BE REMOVED.
9. ALL CONDUITS SHALL BE SWABBED CLEAN BY PULLING AN APPROPRIATE SIZE MANDREL THROUGH THE CONDUIT BEFORE INSTALLATION OF CONDUCTORS OR CABLES. CONDUIT SHALL BE FREE OF DIRT AND DEBRIS.
10. INSTALL PULL STRINGS IN ALL CLEAN EMPTY CONDUITS. IDENTIFY PULL STRINGS AT EACH END.
11. INSTALL 2" HIGHLY VISIBLE AND DETECTABLE TAPE 12" ABOVE ALL UNDERGROUND CONDUITS AND CONDUCTORS.
12. CONDUITS SHALL BE INSTALLED IN SUCH A MANNER AS TO INSURE AGAINST COLLECTION OF TRAPPED CONDENSATION.
13. PROVIDE CORE DRILLING AS NECESSARY FOR PENETRATIONS TO ALLOW FOR RACEWAYS AND CABLES TO BE ROUTED THROUGH THE BUILDING. DO NOT PENETRATE STRUCTURAL MEMBERS. SLEEVES AND/OR PENETRATIONS IN FIRE RATED CONSTRUCTION SHALL BE EFFECTIVELY SEALED WITH FIRE RATED MATERIAL WHICH SHALL MAINTAIN THE FIRE RATING OF THE WALL OR STRUCTURE. FIRE STOPS AT FLOOR PENETRATIONS SHALL PREVENT PASSAGE OF WATER, SMOKE, FIRE, AND FUMES. ALL MATERIAL SHALL BE UL APPROVED FOR THIS PURPOSE.

B. CONDUCTORS AND CABLE:

- 1. ALL POWER WIRING SHALL BE COLOR CODED AS FOLLOWS:
DESCRIPTION 208/240/120 VOLT SYSTEMS
PHASE A BLACK
PHASE B RED
PHASE C BLUE
NEUTRAL WHITE
GROUNDING GREEN
2. SPLICES SHALL BE MADE ONLY AT OUTLETS, JUNCTION BOXES, OR ACCESSIBLE RACEWAY CONDUITS APPROVED FOR THIS PURPOSE.

- 3. PULLING LUBRICANTS SHALL BE UL APPROVED. CONTRACTOR SHALL USE NYLON OR HEMP ROPE FOR PULLING CONDUCTOR OR CABLES INTO THE CONDUIT.
4. CABLES SHALL BE NEATLY TRAINED, WITHOUT INTERLACING, AND BE OF SUFFICIENT LENGTH IN ALL BOXES & EQUIPMENT TO PERMIT MAKING A NEAT ARRANGEMENT. CABLES SHALL BE SECURED IN A MANNER TO AVOID TENSION ON CONDUCTORS OR TERMINALS. CONDUCTORS SHALL BE PROTECTED FROM MECHANICAL INJURY AND MOISTURE. SHARP BENDS OVER CONDUIT BUSHINGS IS PROHIBITED. DAMAGED CABLES SHALL BE REMOVED AND REPLACED AT THE CONTRACTOR'S EXPENSE.
C. DISCONNECT SWITCHES:
1. INSTALL DISCONNECT SWITCHES LEVEL AND PLUMB. CONNECT TO WIRING SYSTEM AND GROUNDING SYSTEM AS INDICATED.
D. GROUNDING:
1. ALL METALLIC PARTS OF ELECTRICAL EQUIPMENT WHICH DO NOT CARRY CURRENT SHALL BE GROUNDED IN ACCORDANCE WITH THE REQUIREMENTS OF THE BUILDING MANUFACTURER, AT&T GROUNDING AND BONDING STANDARDS TP-76416, ND-00135, AND THE NATIONAL ELECTRICAL CODE.
2. PROVIDE ELECTRICAL GROUNDING AND BONDING SYSTEM INDICATED WITH ASSEMBLY OF MATERIALS, INCLUDING GROUNDING ELECTRODES, BONDING JUMPERS AND ADDITIONAL ACCESSORIES AS REQUIRED FOR A COMPLETE INSTALLATION.
3. ALL GROUNDING CONDUCTORS SHALL PROVIDE A STRAIGHT DOWNWARD PATH TO GROUND WITH GRADUAL BEND AS REQUIRED. GROUNDING CONDUCTORS SHALL NOT BE LOOPED OR SHARPLY BENT. ROUTE GROUNDING CONNECTIONS AND CONDUCTORS TO GROUND IN THE SHORTEST AND STRAIGHTEST PATHS POSSIBLE TO MINIMIZE TRANSIENT VOLTAGE RISES.
4. BUILDINGS AND/OR NEW TOWERS GREATER THAN 75 FEET IN HEIGHT AND WHERE THE MAIN GROUNDING CONDUCTORS ARE REQUIRED TO BE ROUTED TO GRADE, THE CONTRACTOR SHALL ROUTE TWO GROUNDING CONDUCTORS FROM THE ROOFTOP, TOWERS, AND WATER TOWERS GROUNDING RING, TO THE EXISTING GROUNDING SYSTEM. THE GROUNDING CONDUCTORS SHALL NOT BE SMALLER THAN 2/0 AWG COPPER. ROOFTOP GROUNDING RING SHALL BE BONDED TO THE EXISTING GROUNDING SYSTEM, THE BUILDING STEEL COLUMNS, LIGHTNING PROTECTION SYSTEM, AND BUILDING MAIN WATER LINE (FERROUS OR NONFERROUS METAL PIPING ONLY). SEE STANDARD 6.3.2.2.
5. TIGHTEN GROUNDING AND BONDING CONNECTORS, INCLUDING SCREWS AND BOLTS, IN ACCORDANCE WITH MANUFACTURER'S PUBLISHED TORQUE TIGHTENING VALUES FOR CONNECTORS AND BOLTS. WHERE MANUFACTURER'S TORQUIING REQUIREMENTS ARE NOT AVAILABLE, TIGHTEN CONNECTIONS TO COMPLY WITH TIGHTENING TORQUE VALUES SPECIFIED IN UL TO ASSURE PERMANENT AND EFFECTIVE GROUNDING.
6. CONTRACTOR SHALL VERIFY THE LOCATIONS OF GROUNDING TIE-IN-POINTS TO THE EXISTING GROUNDING SYSTEM. ALL UNDERGROUND GROUNDING CONNECTIONS SHALL BE MADE BY THE EXOTHERMIC WELD PROCESS AND INSTALLED IN ACCORDANCE WITH THE MANUFACTURER'S INSTRUCTIONS.
7. ALL GROUNDING CONNECTIONS SHALL BE INSPECTED FOR TIGHTNESS. EXOTHERMIC WELDED CONNECTIONS SHALL BE APPROVED BY THE INSPECTOR HAVING JURISDICTION BEFORE BEING PERMANENTLY CONCEALED.
8. APPLY CORROSION-RESISTANT FINISH TO FIELD CONNECTIONS AND PLACES WHERE FACTORY APPLIED PROTECTIVE COATINGS HAVE BEEN DESTROYED. USE KOPR-SHIELD ANTI-OXIDATION COMPOUND ON ALL COMPRESSION GROUNDING CONNECTIONS.
9. A SEPARATE, CONTINUOUS, INSULATED EQUIPMENT GROUNDING CONDUCTOR SHALL BE INSTALLED IN ALL FEEDER AND BRANCH CIRCUITS.
10. BOND ALL INSULATED GROUNDING BUSHINGS WITH A BARE #6 AWG GROUNDING CONDUCTOR TO A GROUND BUS.
11. DIRECT BURIED GROUNDING CONDUCTORS SHALL BE INSTALLED AT A NOMINAL DEPTH OF 36" MINIMUM BELOW GRADE, OR 6" BELOW THE FROST LINE, USE THE GREATER OF THE TWO DISTANCES.
12. ALL GROUNDING CONDUCTORS EMBEDDED IN OR PENETRATING CONCRETE SHALL BE INSTALLED IN SCHEDULE 40 PVC CONDUIT.
13. THE INSTALLATION OF CHEMICAL ELECTROLYTIC GROUNDING SYSTEM IN STRICT ACCORDANCE WITH MANUFACTURER'S INSTRUCTIONS. REMOVE SEALING TAPE FROM LEACHING AND BREATHER HOLES. INSTALL PROTECTIVE BOX FLUSH WITH GRADE.
14. DRIVE GROUND RODS UNTIL TOPS ARE A MINIMUM DISTANCE OF 36" DEPTH OR 6" BELOW FROST LINE, USING THE GREATER OF THE TWO DISTANCES.
15. IF COAX ON THE ICE BRIDGE IS MORE THAN 6 FT. FROM THE GROUNDING BAR AT THE BASE OF THE TOWER, A SECOND GROUNDING BAR WILL BE NEEDED AT THE END OF THE ICE BRIDGE, TO GROUND THE COAX CABLE GROUNDING KITS AND IN-LINE ARRESTORS.
16. CONTRACTOR SHALL REPAIR, AND/OR REPLACE, EXISTING GROUNDING SYSTEM COMPONENTS DAMAGED DURING CONSTRUCTION AT THE CONTRACTORS EXPENSE.

3.5 ACCEPTANCE TESTING:

- A. CERTIFIED PERSONNEL USING CERTIFIED EQUIPMENT SHALL PERFORM REQUIRED TESTS AND SUBMIT WRITTEN TEST REPORTS UPON COMPLETION.
B. WHEN MATERIAL AND/OR WORKMANSHIP IS FOUND NOT TO COMPLY WITH THE SPECIFIED REQUIREMENTS, THE NON-COMPLYING ITEMS SHALL BE REMOVED FROM THE PROJECT SITE AND REPLACED WITH ITEMS COMPLYING WITH THE SPECIFIED REQUIREMENTS PROMPTLY AFTER RECEIPT OF NOTICE FOR NON-COMPLIANCE.
C. TEST PROCEDURES:
1. ALL FEEDERS SHALL HAVE INSULATION TESTED AFTER INSTALLATION, BEFORE CONNECTION TO DEVICES. THE CONDUCTORS SHALL TEST FREE FROM SHORT CIRCUITS AND GROUNDS. TESTING SHALL BE FOR ONE MINUTE USING 1000V DC. PROVIDE WRITTEN DOCUMENTATION FOR ALL TEST RESULTS.
2. PRIOR TO ENERGIZING CIRCUITRY, TEST WIRING DEVICES FOR ELECTRICAL CONTINUITY AND PROPER POLARITY CONNECTIONS.
3. MEASURE AND RECORD VOLTAGES BETWEEN PHASES AND BETWEEN PHASE CONDUCTORS AND NEUTRALS. SUBMIT A REPORT OF MAXIMUM AND MINIMUM VOLTAGES.
4. PERFORM GROUNDING TEST TO MEASURE GROUNDING RESISTANCE OF GROUNDING SYSTEM USING THE IEEE STANDARD 3-POINT "FALL-OF-POTENTIAL" METHOD. PROVIDE PLOTTED TEST VALUES AND LOCATION SKETCH. NOTIFY THE ENGINEER IMMEDIATELY IF MEASURED VALUE IS OVER 5 OHMS.

AT&T logo and address: 188 INVERNESS DRIVE WEST SUITE 400 ENGLEWOOD, CO 80112

PYRAMID Network Services, LLC logo and address: 6615 TOWPATH ROAD EAST SYRACUSE, NY 13057

GPD GROUP logo and address: 520 South Main Street, Suite 2531 Akron, OH 44311

Table with 2 columns: Field Name, Value. GPD JOB #: 2025705.79, DRAWN BY: ACM, CHECKED BY: LJB, RFDS: 25309

Table with 3 columns: Rev, Date, Description. Includes revision history for construction and review.

Professional Engineer Seal for Steven P. Schaub, E-76700, Registered Engineer, State of Ohio, dated 08/27/2025.

SHANNON PARK SOH3625 6790 COFFMAN RD DUBLIN, OH 43017 COLOCATION

SHEET TITLE ELECTRICAL AND GROUNDING NOTES

SHEET NUMBER G-5

EXOTHERMIC CONNECTION	
MECHANICAL CONNECTION	
CHEMICAL ELECTROLYTIC GROUNDING SYSTEM	
TEST CHEMICAL ELECTROLYTIC GROUNDING SYSTEM	
EXOTHERMIC WITH INSPECTION SLEEVE	
GROUNDING BAR	
GROUND ROD	
TEST GROUND ROD WITH INSPECTION SLEEVE	
SINGLE POLE SWITCH	
DUPLEX RECEPTACLE	
DUPLEX GFCI RECEPTACLE	
FLUORESCENT LIGHTING FIXTURE (2) TWO LAMPS 48-T8	
SMOKE DETECTION (DC)	
EMERGENCY LIGHTING (DC)	
SECURITY LIGHT W/PHOTOCELL LITHONIA ALXW LED-1-25A400/51K-SR4-120-PE-DDBTXD	
CHAIN LINK FENCE	
WOOD/WROUGHT IRON FENCE	
WALL STRUCTURE	
LEASE AREA	
PROPERTY LINE (PL)	
SETBACKS	
ICE BRIDGE	
CABLE TRAY	
WATER LINE	
UNDERGROUND POWER	
UNDERGROUND TELCO	
OVERHEAD POWER	
OVERHEAD TELCO	
UNDERGROUND TELCO/POWER	
ABOVE GROUND POWER	
ABOVE GROUND TELCO	
ABOVE GROUND TELCO/POWER	
WORKPOINT	
SECTION REFERENCE	
DETAIL REFERENCE	

AB	ANCHOR BOLT	IGR	INTERIOR GROUND RING
ABV	ABOVE	IN	INCH
AC	ALTERNATING CURRENT	INT	INTERIOR
ADDL	ADDITIONAL	LB(S)	POUND(S)
AFF	ABOVE FINISHED FLOOR	LF	LINEAR FEET
AFG	ABOVE FINISHED GRADE	LTE	LONG TERM EVOLUTION
AGL	ABOVE GROUND LEVEL	MAS	MASONRY
AIC	AMPERAGE INTERRUPTION CAPACITY	MAX	MAXIMUM
ALUM	ALUMINUM	MB	MACHINE BOLT
ALT	ALTERNATE	MECH	MECHANICAL
ANT	ANTENNA	MFR	MANUFACTURER
APPROX	APPROXIMATE	MGB	MASTER GROUND BAR
ARCH	ARCHITECTURAL	MIN	MINIMUM
ATS	AUTOMATIC TRANSFER SWITCH	MISC	MISCELLANEOUS
AWG	AMERICAN WIRE GAUGE	MTL	METAL
BATT	BATTERY	MTS	MANUAL TRANSFER SWITCH
BLDG	BUILDING	MW	MICROWAVE
BLK	BLOCK	NEC	NATIONAL ELECTRIC CODE
BLKG	BLOCKING	NM	NEWTON METERS
BM	BEAM	NO.	NUMBER
BTC	BARE TINNED COPPER CONDUCTOR	#	NUMBER
BOF	BOTTOM OF FOOTING	NTS	NOT TO SCALE
CAB	CABINET	OC	ON-CENTER
CANT	CANTILEVERED	OSHA	OCCUPATIONAL SAFETY AND HEALTH ADMINISTRATION
CHG	CHARGING	OPNG	OPENING
CLG	CEILING	P/C	PRECAST CONCRETE
CLR	CLEAR	PCS	PERSONAL COMMUNICATION SERVICES
COL	COLUMN	PCU	PRIMARY CONTROL UNIT
COMM	COMMON	PRC	PRIMARY RADIO CABINET
CONC	CONCRETE	PP	POLARIZING PRESERVING
CONSTR	CONSTRUCTION	PSF	POUNDS PER SQUARE FOOT
DBL	DOUBLE	PSI	POUNDS PER SQUARE INCH
DC	DIRECT CURRENT	PT	PRESSURE TREATED
DEPT	DEPARTMENT	PWR	POWER CABINET
DF	DOUGLAS FIR	QTY	QUANTITY
DIA	DIAMETER	RAD	RADIUS
DIAG	DIAGONAL	RECT	RECTIFIER
DIM	DIMENSION	REF	REFERENCE
DWG	DRAWING	REINF	REINFORCEMENT
DWL	DOWEL	REQ'D	REQUIRED
EA	EACH	RET	REMOTE ELECTRIC TILT
EC	ELECTRICAL CONDUCTOR	RF	RADIO FREQUENCY
EL	ELEVATION	RMC	RIGID METALLIC CONDUIT
ELEC	ELECTRICAL	RRH	REMOTE RADIO HEAD
EMT	ELECTRICAL METALLIC TUBING	RRU	REMOTE RADIO UNIT
ENG	ENGINEER	RWY	RACEWAY
EQ	EQUAL	SCH	SCHEDULE
EXP	EXPANSION	SHT	SHEET
EXT	EXTERIOR	SIAD	SMART INTEGRATED ACCESS DEVICE
EW	EACH WAY	SIM	SIMILAR
FAB	FABRICATION	SPEC	SPECIFICATION
FF	FINISH FLOOR	SQ	SQUARE
FG	FINISH GRADE	SS	STAINLESS STEEL
FIF	FACILITY INTERFACE FRAME	STD	STANDARD
FIN	FINISH(ED)	STL	STEEL
FLR	FLOOR	TEMP	TEMPORARY
FDN	FOUNDATION	THK	THICKNESS
FOC	FACE OF CONCRETE	TMA	TOWER MOUNTED AMPLIFIER
FOM	FACE OF MASONRY	TN	TOE NAIL
FOS	FACE OF STUD	TOA	TOP OF ANTENNA
FOW	FACE OF WALL	TOC	TOP OF CURB
FS	FINISH SURFACE	TOF	TOP OF FOUNDATION
FT	FOOT	TOP	TOP OF PLATE (PARAPET)
FTG	FOOTING	TOS	TOP OF STEEL
GA	GAUGE	TOW	TOP OF WALL
GEN	GENERATOR	TVSS	TRANSIENT VOLTAGE SURGE SUPPRESSION
GFCI	GROUND FAULT CIRCUIT INTERRUPTER	TYP	TYPICAL
GLB	GLUE LAMINATED BEAM	UG	UNDERGROUND
GLV	GALVANIZED	UL	UNDERWRITERS LABORATORY
GPS	GLOBAL POSITIONING SYSTEM	UNO	UNLESS NOTED OTHERWISE
GND	GROUND	UMTS	UNIVERSAL MOBILE TELECOMMUNICATIONS SYSTEM
GSM	GLOBAL SYSTEM FOR MOBILE	UPS	UNINTERRUPTIBLE POWER SYSTEM (DC POWER PLANT)
HDG	HOT DIPPED GALVANIZED	VIF	VERIFIED IN FIELD
HDR	HEADER	W	WIDE
HGR	HANGER	W/	WITH
HVAC	HEAT/VENTILATION/AIR CONDITIONING	WD	WOOD
HT	HEIGHT	WP	WEATHERPROOF
		WT	WEIGHT

LEGEND

ABBREVIATIONS

188 INVERNESS DRIVE WEST
SUITE 400
ENGLEWOOD, CO 80112

6615 TOWPATH ROAD
EAST SYRACUSE, NY 13057

520 South Main Street, Suite 2531
Akron, OH 44311
330.572.2100 Fax 330.572.2101
Copyright: Glau, Pyle, Schomer, Burns & DeHaven, Inc. 2025

GPD JOB #:	2025705.79
DRAWN BY:	ACM
CHECKED BY:	LJB
RFDS:	25309

REV	DATE	DESCRIPTION
0	08/27/2025	FOR CONSTRUCTION
C	08/15/2025	REV. PER COMMENTS
B	08/12/2025	REV. PER COMMENTS
A	06/05/2025	ISSUED FOR REVIEW

IT IS A VIOLATION OF LAW FOR ANY PERSON, UNLESS THEY ARE ACTING UNDER THE DIRECTION OF A LICENSED PROFESSIONAL ENGINEER, TO ALTER THIS DOCUMENT.

SHANNON PARK
SOH3625
6790 COFFMAN RD
DUBLIN, OH 43017
COLOCATION

SHEET TITLE
LEGEND & ABBREVIATIONS

SHEET NUMBER
GN-1

GENERAL CONSTRUCTION

1. FOR THE PURPOSE OF CONSTRUCTION DRAWINGS, THE FOLLOWING DEFINITIONS SHALL APPLY:

GENERAL CONTRACTOR - (MasTec)
CONTRACTOR, (CONSTRUCTION)
OWNER - AT&T

- 2. ALL SITE WORK SHALL BE COMPLETED AS INDICATED ON THE DRAWINGS AND AT&T PROJECT SPECIFICATIONS.
- 3. GENERAL CONTRACTOR SHALL VISIT THE SITE AND SHALL FAMILIARIZE HIMSELF WITH ALL CONDITIONS AFFECTING THE PROPOSED WORK AND SHALL MAKE PROVISIONS. GENERAL CONTRACTOR SHALL BE RESPONSIBLE FOR FAMILIARIZING HIMSELF WITH ALL CONTRACT DOCUMENTS, FIELD CONDITIONS, DIMENSIONS, AND CONFIRMING THAT THE WORK MAY BE ACCOMPLISHED AS SHOWN PRIOR TO PROCEEDING WITH CONSTRUCTION. ANY DISCREPANCIES SHALL BE BROUGHT TO THE ATTENTION OF THE ENGINEER PRIOR TO THE COMMENCEMENT OF WORK.
- 4. ALL MATERIALS FURNISHED AND INSTALLED SHALL BE IN STRICT ACCORDANCE WITH ALL APPLICABLE CODES, REGULATIONS, AND ORDINANCES. GENERAL CONTRACTOR SHALL ISSUE ALL APPROPRIATE NOTICES AND COMPLY WITH ALL LAWS, ORDINANCES, RULES, REGULATIONS, AND LAWFUL ORDERS OF ANY PUBLIC AUTHORITY REGARDING THE PERFORMANCE OF WORK.
- 5. ALL WORK CARRIED OUT SHALL COMPLY WITH ALL APPLICABLE MUNICIPAL AND UTILITY COMPANY SPECIFICATIONS AND LOCAL JURISDICTIONAL CODES, ORDINANCES, AND APPLICABLE REGULATIONS.
- 6. UNLESS NOTED OTHERWISE, THE WORK SHALL INCLUDE FURNISHING MATERIALS, EQUIPMENT, APPURTENANCES, AND LABOR NECESSARY TO COMPLETE ALL INSTALLATIONS AS INDICATED ON THE DRAWINGS.
- 7. PLANS ARE NOT TO BE SCALED. THESE PLANS ARE INTENDED TO BE A DIAGRAMMATIC OUTLINE ONLY UNLESS OTHERWISE NOTED. DIMENSIONS SHOWN ARE TO FINISH SURFACES UNLESS OTHERWISE NOTED. SPACING BETWEEN EQUIPMENT IS THE MINIMUM REQUIRED CLEARANCE. THEREFORE, IT IS CRITICAL TO FIELD VERIFY DIMENSIONS. SHOULD THERE BE ANY QUESTIONS REGARDING THE CONTRACT DOCUMENTS, THE CONTRACTOR SHALL BE RESPONSIBLE FOR OBTAINING A CLARIFICATION FROM THE ENGINEER PRIOR TO PROCEEDING WITH THE WORK. DETAILS ARE INTENDED TO SHOW DESIGN INTENT. MODIFICATIONS MAY BE REQUIRED TO SUIT JOB DIMENSIONS OR CONDITIONS AND SUCH MODIFICATIONS SHALL BE INCLUDED AS PART OF WORK AND PREPARED BY THE ENGINEER PRIOR TO PROCEEDING WITH WORK.
- 8. THE CONTRACTOR SHALL INSTALL ALL EQUIPMENT AND MATERIALS IN ACCORDANCE WITH MANUFACTURER'S RECOMMENDATIONS UNLESS SPECIFICALLY STATED OTHERWISE.
- 9. IF THE SPECIFIED EQUIPMENT CANNOT BE INSTALLED AS SHOWN ON THESE DRAWINGS, THE CONTRACTOR SHALL PROPOSE AN ALTERNATIVE INSTALLATION SPACE FOR APPROVAL BY THE ENGINEER PRIOR TO PROCEEDING.
- 10. GENERAL CONTRACTOR SHALL BE RESPONSIBLE FOR THE SAFETY OF WORK AREA, ADJACENT AREAS AND BUILDING OCCUPANTS THAT ARE LIKELY TO BE AFFECTED BY THE WORK UNDER THIS CONTRACT. WORK SHALL CONFIRM TO ALL OSHA REQUIREMENTS AND THE LOCAL JURISDICTION.
- 11. GENERAL CONTRACTOR SHALL COORDINATE WORK AND SCHEDULE WORK ACTIVITIES WITH OTHER DISCIPLINES.
- 12. ERECTION SHALL BE DONE IN A WORKMANLIKE MANNER BY COMPETENT EXPERIENCED WORKMAN IN ACCORDANCE WITH APPLICABLE CODES AND THE BEST ACCEPTED PRACTICE. ALL MEMBERS SHALL BE LAID PLUMB AND TRUE AS INDICATED ON THE DRAWINGS.
- 13. SEAL PENETRATIONS THROUGH FIRE RATED AREAS WITH UL LISTED MATERIALS APPROVED BY LOCAL JURISDICTION. CONTRACTOR SHALL KEEP AREA CLEAN, HAZARD FREE, AND DISPOSE OF ALL DEBRIS.
- 14. WORK PREVIOUSLY COMPLETED IS REPRESENTED BY LIGHT SHADED LINES AND NOTES. THE SCOPE OF WORK FOR THIS PROJECT IS REPRESENTED BY DARK SHADED LINES AND NOTES. CONTRACTOR SHALL NOTIFY THE GENERAL CONTRACTOR OF ANY EXISTING CONDITIONS THAT DEVIATE FROM THE DRAWINGS PRIOR TO BEGINNING CONSTRUCTION.
- 15. CONTRACTOR SHALL PROVIDE WRITTEN NOTICE TO THE CONSTRUCTION MANAGER 48 HOURS PRIOR TO COMMENCEMENT OF WORK.
- 16. THE CONTRACTOR SHALL PROTECT EXISTING IMPROVEMENTS, PAVEMENTS, CURBS, LANDSCAPING AND STRUCTURES. ANY DAMAGED PART SHALL BE REPAIRED AT CONTRACTOR'S EXPENSE TO THE SATISFACTION OF THE OWNER.
- 17. THE CONTRACTOR SHALL CONTACT UTILITY LOCATING SERVICES PRIOR TO THE START OF CONSTRUCTION.
- 18. GENERAL CONTRACTOR SHALL COORDINATE AND MAINTAIN ACCESS FOR ALL TRADES AND CONTRACTORS TO THE SITE AND/OR BUILDING.
- 19. THE GENERAL CONTRACTOR SHALL BE RESPONSIBLE FOR SECURITY OF THE SITE FOR THE DURATION OF CONSTRUCTION UNTIL JOB COMPLETION.
- 20. THE GENERAL CONTRACTOR SHALL MAINTAIN IN GOOD CONDITION ONE COMPLETE SET OF PLANS WITH ALL REVISIONS, ADDENDA, AND CHANGE ORDERS ON THE PREMISES AT ALL TIMES.
- 21. THE GENERAL CONTRACTOR SHALL PROVIDE PORTABLE FIRE EXTINGUISHERS WITH A RATING OF NOT LESS THAN 2-A 20 2-A-10-B-C AND SHALL BE WITHIN 25 FEET OF TRAVEL DISTANCE TO ALL PORTIONS OF WHERE THE WORK IS BEING COMPLETED DURING CONSTRUCTION.
- 22. ALL EXISTING ACTIVE SEWER, WATER, GAS, ELECTRIC, AND OTHER UTILITIES SHALL BE PROTECTED AT ALL TIMES, AND WHERE REQUIRED FOR THE PROPER EXECUTION OF THE WORK, SHALL BE RELOCATED AS DIRECTED BY THE ENGINEER. EXTREME CAUTION SHOULD BE USED BY THE CONTRACTOR WHEN EXCAVATING OR DRILLING PIERS AROUND OR NEAR UTILITIES. CONTRACTOR SHALL PROVIDE SAFETY TRAINING FOR THE WORKING CREW. THIS SHALL INCLUDE BUT NOT BE LIMITED TO A) FALL PROTECTION, B) CONFINED SPACE, C) ELECTRICAL SAFETY, AND D) TRENCHING & EXCAVATION.
- 23. ALL EXISTING INACTIVE SEWER, WATER, GAS, ELECTRIC, AND OTHER UTILITIES, WHICH INTERFERE WITH THE EXECUTION OF THE WORK, SHALL BE REMOVED, CAPPED, PLUGGED OR OTHERWISE DISCONNECTED AT POINTS WHICH WILL NOT INTERFERE WITH THE EXECUTION OF THE WORK, AS DIRECTED BY THE RESPONSIBLE ENGINEER, AND SUBJECT TO THE APPROVAL OF THE OWNER AND/OR LOCAL UTILITIES.
- 24. THE AREAS OF THE OWNER'S PROPERTY DISTURBED BY THE WORK AND NOT COVERED BY THE TOWER, EQUIPMENT OR DRIVEWAY, SHALL BE GRADED TO A UNIFORM SLOPE, AND STABILIZED TO PREVENT EROSION.
- 25. CONTRACTOR SHALL MINIMIZE DISTURBANCE TO THE EXISTING SITE DURING CONSTRUCTION. EROSION CONTROL MEASURES, IF REQUIRED DURING CONSTRUCTION, SHALL BE IN CONFORMANCE WITH THE FEDERAL AND LOCAL JURISDICTION FOR EROSION AND SEDIMENT CONTROL.
- 26. NO FILL OR EMBANKMENT MATERIAL SHALL BE PLACED ON FROZEN GROUNDING, FROZEN MATERIALS, SNOW OR ICE SHALL NOT BE PLACED IN ANY FILL OR EMBANKMENT.
- 27. THE SUBGRADE SHALL BE BROUGHT TO A SMOOTH UNIFORM GRADE AND COMPACTED TO 95 PERCENT STANDARD PROCTOR DENSITY UNDER PAVEMENT AND STRUCTURES AND 80 PERCENT STANDARD PROCTOR DENSITY IN OPEN SPACE. ALL TRENCHES IN PUBLIC RIGHT OF WAY SHALL BE BACKFILLED WITH FLOWABLE FILL OR OTHER MATERIAL PRE-APPROVED BY THE LOCAL JURISDICTION.
- 28. ALL NECESSARY RUBBISH, STUMPS, DEBRIS, STICKS, STONES, AND OTHER REFUSE SHALL BE REMOVED FROM THE SITE AND DISPOSED OF IN A LAWFUL MANNER.
- 29. ALL BROCHURES, OPERATING AND MAINTENANCE MANUALS, CATALOGS, SHOP DRAWINGS, AND OTHER DOCUMENTS SHALL BE TURNED OVER TO THE GENERAL CONTRACTOR AT COMPLETION OF CONSTRUCTION AND PRIOR TO PAYMENT.
- 30. CONTRACTOR SHALL SUBMIT A COMPLETE SET OF AS-BUILT REDLINES TO THE GENERAL CONTRACTOR UPON COMPLETION OF PROJECT AND PRIOR TO FINAL PAYMENT.

- 31. CONTRACTOR SHALL LEAVE PREMISES IN A CLEAN CONDITION.
- 32. THE PROPOSED FACILITY WILL BE UNMANNED AND DOES NOT REQUIRE POTABLE WATER OR SEWER SERVICE, AND IS NOT FOR HUMAN HABITAT (NO HANDICAP ACCESS REQUIRED).
- 33. OCCUPANCY IS LIMITED TO PERIODIC MAINTENANCE AND INSPECTION, APPROXIMATELY 2 TIMES PER MONTH, BY AT&T TECHNICIANS.
- 34. NO OUTDOOR STORAGE OR SOLID WASTE CONTAINERS ARE PROPOSED.
- 35. ALL MATERIAL SHALL BE FURNISHED AND WORK SHALL BE PERFORMED IN ACCORDANCE WITH THE LATEST REVISION AT&T MOBILITY GROUNDING STANDARD "TECHNICAL SPECIFICATION FOR CONSTRUCTION OF GSM/GPRS WIRELESS SITES" AND "TECHNICAL SPECIFICATION FOR FACILITY GROUNDING". IN CASE OF A CONFLICT BETWEEN THE CONSTRUCTION SPECIFICATION AND THE DRAWINGS, THE DRAWINGS SHALL GOVERN.
- 36. CONTRACTORS SHALL BE RESPONSIBLE FOR OBTAINING ALL PERMITS AND INSPECTIONS REQUIRED FOR CONSTRUCTION. IF CONTRACTOR CANNOT OBTAIN A PERMIT, THEY MUST NOTIFY THE GENERAL CONTRACTOR IMMEDIATELY.
- 37. CONTRACTOR SHALL REMOVE ALL TRASH AND DEBRIS FROM THE SITE ON A DAILY BASIS.
- 38. INFORMATION SHOWN ON THESE DRAWINGS WAS OBTAINED FROM SITE VISITS AND/OR DRAWINGS PROVIDED BY THE SITE OWNER. CONTRACTORS SHALL NOTIFY THE ENGINEER OF ANY DISCREPANCIES PRIOR TO ORDERING MATERIAL OR PROCEEDING WITH CONSTRUCTION.
- 39. NO WHITE STROBE LIGHTS ARE PERMITTED. LIGHTING IF REQUIRED, WILL MEET FAA STANDARDS AND REQUIREMENTS.
- 40. ALL COAXIAL CABLE INSTALLATIONS TO FOLLOW MANUFACTURER'S INSTRUCTIONS AND RECOMMENDATIONS.

ANTENNA MOUNTING

- 41. DESIGN AND CONSTRUCTION OF ANTENNA SUPPORTS SHALL CONFORM TO CURRENT ANSI/TIA-222 OR APPLICABLE LOCAL CODES.
- 42. ALL STEEL MATERIALS SHALL BE GALVANIZED AFTER FABRICATION IN ACCORDANCE WITH ASTM A123 "ZINC (HOT-DIP GALVANIZED) COATINGS ON IRON AND STEEL PRODUCTS", UNLESS NOTED OTHERWISE.
- 43. ALL BOLTS, ANCHORS AND MISCELLANEOUS HARDWARE SHALL BE GALVANIZED IN ACCORDANCE WITH ASTM A153 "ZINC-COATING (HOT-DIP) ON IRON AND STEEL HARDWARE", UNLESS NOTED OTHERWISE.
- 44. DAMAGED GALVANIZED SURFACES SHALL BE REPAIRED BY COLD GALVANIZING IN ACCORDANCE WITH ASTM A780.
- 45. ALL ANTENNA MOUNTS SHALL BE INSTALLED WITH LOCK NUTS, DOUBLE NUTS AND SHALL BE TORQUED TO MANUFACTURER'S RECOMMENDATIONS.
- 46. CONTRACTOR SHALL INSTALL ANTENNA PER MANUFACTURER'S RECOMMENDATION FOR INSTALLATION AND GROUNDING.
- 47. ALL UNUSED PORTS ON ANY ANTENNAS SHALL BE TERMINATED WITH A 50-OHM LOAD TO ENSURE ANTENNAS PERFORM AS DESIGNED.
- 48. PRIOR TO SETTING ANTENNA AZIMUTHS AND DOWNTILTS, ANTENNA CONTRACTOR SHALL CHECK THE ANTENNA MOUNT FOR TIGHTNESS AND ENSURE THAT THEY ARE PLUMB. ANTENNA AZIMUTHS SHALL BE SET FROM TRUE NORTH AND BE ORIENTED WITHIN +/- 5% AS DEFINED BY THE RFDS. ANTENNA DOWNTILTS SHALL BE WITHIN +/- 0.5% AS DEFINED BY THE RFDS. REFER TO ND-00246.
- 49. JUMPERS FROM THE TMA'S MUST TERMINATE TO OPPOSITE POLARIZATION'S IN EACH SECTOR.
- 50. CONTRACTOR SHALL RECORD THE SERIAL #, SECTOR, AND POSITION OF EACH ACTUATOR INSTALLED AT THE ANTENNAS AND PROVIDE THE INFORMATION TO AT&T.
- 51. TMA'S SHALL BE MOUNTED ON PIPE DIRECTLY BEHIND ANTENNAS AS CLOSE TO ANTENNA AS FEASIBLE IN A VERTICAL POSITION.
- 52. ANTENNAS SHALL HAVE A 4'-0" MIN CENTER TO CENTER HORIZONTAL SEPARATION.

TORQUE REQUIREMENTS

- 53. ALL RF CONNECTIONS SHALL BE TIGHTENED BY A TORQUE WRENCH.
- 54. ALL RF CONNECTIONS, GROUNDING HARDWARE AND ANTENNA HARDWARE SHALL HAVE A TORQUE MARK INSTALLED IN A CONTINUOUS STRAIGHT LINE FROM BOTH SIDES OF THE CONNECTION.
 - A. RF CONNECTION BOTH SIDES OF THE CONNECTOR.
 - B. GROUNDING AND ANTENNA HARDWARE ON THE NUT SIDE STARTING FROM THE THREADS TO THE SOLID SURFACE. EXAMPLE OF SOLID SURFACE: GROUND BAR, ANTENNA BRACKET METAL.
- 55. ALL 8M ANTENNA HARDWARE SHALL BE TIGHTENED TO 9 LB-FT (12 NM).
- 56. ALL 12M ANTENNA HARDWARE SHALL BE TIGHTENED TO 43 LB-FT (58 NM).
- 57. ALL GROUNDING HARDWARE SHALL BE TIGHTENED UNTIL THE LOCK WASHER COLLAPSES AND THE GROUNDING HARDWARE IS NO LONGER LOOSE.
- 58. ALL DIN TYPE CONNECTIONS SHALL BE TIGHTENED TO 18-22 LB-FT (24.4 - 29.8 NM).
- 59. ALL N TYPE CONNECTIONS SHALL BE TIGHTENED TO 15-20 LB-IN (1.7 - 2.3 NM).

FIBER & POWER CABLE MOUNTING

- 60. THE FIBER OPTIC TRUNK CABLES SHALL BE INSTALLED INTO CONDUITS, CHANNEL CABLE TRAYS, OR CABLE TRAY. WHEN INSTALLING FIBER OPTIC TRUNK CABLES INTO A CABLE TRAY SYSTEM, THEY SHALL BE INSTALLED INTO AN INTER DUCT AND A PARTITION BARRIER SHALL BE INSTALLED BETWEEN THE 600 VOLT CABLES AND THE INTER DUCT TO SEGREGATE CABLE TYPES. OPTIC FIBER TRUNK CABLES SHALL HAVE APPROVED CABLE RESTRAINTS EVERY (60) SIXTY FEET AND SECURELY FASTENED TO THE CABLE TRAY SYSTEM. NFPA 70 (NEC) ARTICLE 770 RULES SHALL APPLY.
- 61. THE TYPE TC-ER CABLES SHALL BE INSTALLED INTO CONDUITS, CHANNEL CABLE TRAYS, OR CABLE TRAY AND SHALL BE SECURED AT INTERVALS NOT EXCEEDING (6) SIX FEET. AN EXCEPTION: WHERE TYPE TC-ER CABLES ARE NOT SUBJECT TO PHYSICAL DAMAGE, CABLES SHALL BE PERMITTED TO MAKE A TRANSITION BETWEEN CONDUITS, CHANNEL CABLE TRAYS, OR CABLE TRAY WHICH ARE SERVING UTILIZATION EQUIPMENT OR DEVICES, A DISTANCE (6) SIX FEET SHALL NOT BE EXCEEDED WITHOUT CONTINUOUS SUPPORTING. NFPA 70 (NEC) ARTICLES 336 AND 392 RULES SHALL APPLY.
- 62. WHEN INSTALLING OPTIC FIBER TRUNK CABLES OR TYPE TC-ER CABLES INTO CONDUITS, NFPA 70 (NEC) ARTICLE 300 RULES SHALL APPLY.

COAXIAL CABLE NOTES

- 63. TYPES AND SIZES OF THE ANTENNA CABLE ARE BASED ON ESTIMATED LENGTHS. PRIOR TO ORDERING CABLE, CONTRACTOR SHALL VERIFY ACTUAL LENGTH BASED ON CONSTRUCTION LAYOUT AND NOTIFY THE PROJECT MANAGER IF ACTUAL LENGTHS EXCEED ESTIMATED LENGTHS.
- 62. CONTRACTOR SHALL VERIFY THE DOWN-TILT OF EACH ANTENNA WITH A DIGITAL LEVEL.
- 63. CONTRACTOR SHALL CONFIRM COAX COLOR CODING PRIOR TO CONSTRUCTION. REFER TO "ANTENNA SYSTEM LABELING STANDARD" ND-00027 LATEST VERSION.
- 64. ALL JUMPERS TO THE ANTENNAS FROM THE MAIN TRANSMISSION LINE SHALL BE 1/2" DIA. LDF AND SHALL NOT EXCEED 6'-0".
- 65. ALL COAXIAL CABLE SHALL BE SECURED TO THE DESIGNED SUPPORT STRUCTURE, IN AN APPROVED MANNER, AT DISTANCES NOT TO EXCEED 4'-0" OC.
- 66. CONTRACTOR SHALL FOLLOW ALL MANUFACTURER'S RECOMMENDATIONS REGARDING BOTH THE INSTALLATION AND GROUNDING OF ALL COAXIAL CABLES, CONNECTORS, ANTENNAS, AND ALL OTHER EQUIPMENT.
- 67. CONTRACTOR SHALL WEATHERPROOF ALL ANTENNA CONNECTORS WITH SELF AMALGAMATING TAPE. WEATHERPROOFING SHALL BE COMPLETED IN STRICT ACCORDANCE WITH AT&T STANDARDS.

GENERAL CABLE AND EQUIPMENT NOTES

- 68. CONTRACTOR SHALL BE RESPONSIBLE TO VERIFY ANTENNA, TMAS, DIPLEXERS, AND COAX CONFIGURATION, MAKE AND MODELS PRIOR TO INSTALLATION.
- 69. ALL CONNECTIONS FOR HANGERS, SUPPORTS, BRACING, ETC. SHALL BE INSTALLED PER TOWER MANUFACTURER'S RECOMMENDATIONS.
- 70. CONTRACTOR SHALL REFERENCE THE TOWER STRUCTURAL ANALYSIS/DESIGN DRAWINGS FOR DIRECTIONS ON CABLE DISTRIBUTION/ROUTING.
- 71. ALL OUTDOOR RF CONNECTORS/CONNECTIONS SHALL BE WEATHERPROOFED, EXCEPT THE RET CONNECTORS, USING BUTYL TAPE AFTER INSTALLATION AND FINAL CONNECTIONS ARE MADE. BUTYL TAPE SHALL HAVE A MINIMUM OF ONE-HALF TAPE WIDTH OVERLAP ON EACH TURN AND EACH LAYER SHALL BE WRAPPED THREE TIMES. WEATHERPROOFING SHALL BE SMOOTH WITHOUT BUCKLING. BUTYL BLEEDING IS NOT ALLOWED.
- 72. IF REQUIRED TO PAINT ANTENNAS AND/OR COAX:
 - A. TEMPERATURE SHALL BE ABOVE 50° F.
 - B. PAINT COLOR MUST BE APPROVED BY BUILDING OWNER/LANDLORD.
 - C. FOR REGULATED TOWERS, FAA/FCC APPROVED PAINT IS REQUIRED.
 - D. DO NOT PAINT OVER COLOR CODING OR ON EQUIPMENT MODEL NUMBERS.
- 73. ALL CABLES SHALL BE GROUNDED WITH COAXIAL CABLE GROUND KITS. FOLLOW THE MANUFACTURER'S RECOMMENDATIONS.
 - A. GROUNDING AT THE ANTENNA LEVEL.
 - B. GROUNDING AT MID LEVEL, TOWERS WHICH ARE OVER 200'-0", ADDITIONAL CABLE GROUNDING REQUIRED.
 - C. GROUNDING AT BASE OF TOWER PRIOR TO TURNING HORIZONTAL.
 - D. GROUNDING OUTSIDE THE EQUIPMENT SHELTER AT ENTRY PORT.
 - E. GROUNDING INSIDE THE EQUIPMENT SHELTER AT THE ENTRY PORT.
- 74. ALL PROPOSED GROUND BAR DOWNLEADS ARE TO BE TERMINATED TO THE EXISTING ADJACENT GROUND BAR DOWNLEADS A MINIMUM DISTANCE OF 4'-0" BELOW GROUND BAR. TERMINATIONS MAY BE EXOTHERMIC OR COMPRESSION.
- 75. THE CONTRACTOR SHALL BE RESPONSIBLE FOR VERIFYING THE ANTENNA AND THE COAX CONFIGURATION IS THE CORRECT MAKE AND MODELS, PRIOR TO INSTALLATION.
- 76. ALL CONNECTIONS FOR HANGERS, SUPPORTS, BRACING, ETC. SHALL BE INSTALLED PER TOWER MANUFACTURER'S SPECIFICATION & RECOMMENDATIONS.
- 77. ANTENNA CONTRACTOR SHALL FURNISH AND INSTALL A 12'-0" T-BOOM SECTOR ANTENNA MOUNT, IF APPLICABLE, INCLUDING ALL HARDWARE.

SAFETY ENFORCEMENT

78. THE CONTRACTOR AND ALL SUBCONTRACTORS SHALL BE RESPONSIBLE FOR THE SAFETY OF THEIR WORK FORCE, THE WORK AREA, ADJACENT AREA, AND ANY PROPERTY OCCUPANTS WHO MAY BE AFFECTED BY THE WORK UNDER CONTRACT. THE CONTRACTOR SHALL REVIEW AND ABIDE BY ALL LANDOWNER, PRIME CONTRACTOR, CARRIER, OSHA, NFPA 70, AND LOCAL SAFETY GUIDELINES. ALL TOWER WORKERS SHALL UTILIZE APPROPRIATE FALL PROTECTION AND SAFETY EQUIPMENT THAT IS UP-TO-DATE AND INSPECTED PER OSHA AND INDUSTRY GUIDELINES. ALL WORKERS SHALL BE TRAINED AND MONITORED TO ENSURE SAFE WORKING PRACTICES ARE MAINTAINED.

SPECIAL INSPECTIONS

79. CONTRACTOR SHALL BE RESPONSIBLE FOR DETERMINING IF ANY SPECIAL INSPECTIONS ARE REQUIRED BY THE JURISDICTION HAVING AUTHORITY. IF REQUIRED BY THE JURISDICTION, THE CONTRACTOR SHALL BE RESPONSIBLE FOR THE COORDINATION AND SCHEDULING OF THE SPECIAL INSPECTIONS WITH THE ENGINEER OF RECORD. IN THOSE CASES, SPECIAL INSPECTIONS MUST BE COMPLETED PRIOR TO FINAL INSPECTION APPROVAL.

1. RFDS TO BE VERIFIED WITH AT&T FOR FINAL VERSION PRIOR TO CONSTRUCTION.

2. CONTRACTOR TO ENSURE ANY RFDS ALTERATIONS ARE COVERED WITHIN THE STRUCTURAL OR TOWER AND FOUNDATION DESIGN.



GPD JOB #:	2025705.79
DRAWN BY:	ACM
CHECKED BY:	LJB
RFDS:	25309

REV	DATE	DESCRIPTION
0	08/27/2025	FOR CONSTRUCTION
C	08/15/2025	REV. PER COMMENTS
B	08/12/2025	REV. PER COMMENTS
A	06/05/2025	ISSUED FOR REVIEW

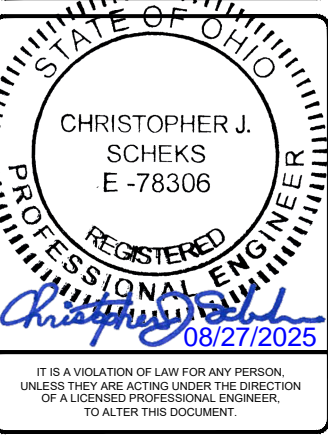

SHANNON PARK
SOH3625
6790 COFFMAN RD
DUBLIN, OH 43017
COLOCATION

SHEET TITLE
GENERAL CONSTRUCTION
NOTES

SHEET NUMBER
GN-2

PART 1 - GENERAL

- CLEARING, GRUBBING, STRIPPING, EROSION CONTROL, SURVEY, LAYOUT, SUBGRADE PREPARATION AND FINISH GRADING AS REQUIRED TO COMPLETE THE PROPOSED WORK SHOWN IN THESE PLANS.
- 1.1 REFERENCES:
- A. DOT (STATE DEPARTMENT OF TRANSPORTATION STANDARD SPECIFICATIONS FOR HIGHWAY CONSTRUCTION-CURRENT EDITION).
 - B. ASTM (AMERICAN SOCIETY FOR TESTING AND MATERIALS).
 - C. OSHA (OCCUPATION SAFETY AND HEALTH ADMINISTRATION).
- 1.2 INSPECTION AND TESTING:
- A. FIELD TESTING OF EARTHWORK COMPACTION AND CONCRETE CYLINDERS SHALL BE PERFORMED BY CONTRACTORS INDEPENDENT TESTING LAB. THIS WORK TO BE COORDINATE BY THE CONTRACTOR.
 - B. ALL WORK SHALL BE INSPECTED AND RELEASED BY THE GENERAL CONTRACTOR WHO SHALL CARRY OUT THE GENERAL INSPECTION OF THE WORK WITH SPECIFIC CONCERN TO PROPER PERFORMANCE OF THE WORK AS SPECIFIED AND/OR CALLED FOR ON THE DRAWINGS. IT IS THE CONTRACTOR'S RESPONSIBILITY TO REQUEST TIMELY INSPECTIONS PRIOR TO PROCEEDING WITH FURTHER WORK THAT WOULD MAKE PARTS OF WORK INACCESSIBLE OR DIFFICULT TO INSPECT.
- 1.3 SITE MAINTENANCE AND PROTECTION:
- A. PROVIDE ALL NECESSARY JOB SITE MAINTENANCE FROM COMMENCEMENT OF WORK UNTIL COMPLETION OF THE SUBCONTRACT.
 - B. AVOID DAMAGE TO THE SITE AND TO EXISTING FACILITIES, STRUCTURES, TREES, AND SHRUBS DESIGNATED TO REMAIN. TAKE PROTECTIVE MEASURES TO PREVENT EXISTING FACILITIES THAT ARE NOT DESIGNATED FOR REMOVAL FROM BEING DAMAGED BY THE WORK.
 - C. KEEP SITE FREE OF ALL PONDING WATER.
 - D. PROVIDE EROSION CONTROL MEASURES IN ACCORDANCE WITH STATE DOT AND EPA REQUIREMENTS.
 - E. PROVIDE AND MAINTAIN ALL TEMPORARY FENCING, BARRICADES, WARNING SIGNALS AND SIMILAR DEVICES NECESSARY TO PROTECT AGAINST THEFT FROM PROPERTY DURING THE ENTIRE PERIOD OF CONSTRUCTION. REMOVE ALL SUCH DEVICES UPON COMPLETION OF THE WORK.
 - F. EXISTING UTILITIES: DO NOT INTERRUPT EXISTING UTILITIES SERVING FACILITIES OCCUPIED BY THE OWNER OR OTHERS, EXCEPT WHEN PERMITTED IN WRITING BY THE ENGINEER AND THEN ONLY AFTER ACCEPTABLE TEMPORARY UTILITY SERVICES HAVE BEEN PROVIDED.
 - 1. PROVIDE A MINIMUM 48 HOURS NOTICE TO THE ENGINEER AND RECEIVE WRITTEN NOTICE TO PROCEED BEFORE INTERRUPTING ANY UTILITY SERVICE.

PART 2 - PRODUCTS

- 2.1 SUITABLE BACKFILL: ASTM D2321 (CLASS I, II, III OR IVA) FREE FROM FROZEN LUMPS, REFUSE, STONES OR ROCKS LARGER THAN 3 INCHES IN ANY DIMENSION OR OTHER MATERIAL THAT MAY MAKE THE INORGANIC MATERIAL UNSUITABLE FOR BACKFILL.
- 2.2 NONPOROUS GRANULAR EMBANKMENT AND BACKFILL: ASTM D2321 (CLASS III, IVA OR IVB) COARSE AGGREGATE, FREE FROM FROZEN LUMPS, REFUSE, STONES OR ROCKS LARGER THAN 3 INCHES IN ANY DIMENSION OR OTHER MATERIAL THAT MAY MAKE THE INORGANIC MATERIAL UNSUITABLE FOR BACKFILL.
- 2.3 POROUS GRANULAR EMBANKMENT AND BACKFILL: ASTM D2321 (CLASS IA, IB OR II) COARSE AGGREGATE FREE FROM FROZEN LUMPS, REFUSE, STONES OR ROCKS LARGER THAN 3 INCHES IN ANY DIMENSION OR OTHER MATERIAL THAT MAY MAKE THE INORGANIC MATERIAL UNSUITABLE FOR BACKFILL.
- 2.4 SELECT STRUCTURAL FILL: GRANULAR FILL MATERIAL MEETING THE REQUIREMENTS OF ASTM E850-95. FOR USE AROUND AND UNDER STRUCTURES WHERE STRUCTURAL FILL MATERIAL ARE REQUIRED.
- 2.5 GRANULAR BEDDING AND TRENCH BACKFILL: WELL-GRADED SAND MEETING THE GRADATION REQUIREMENTS OF ASTM D2487 (SE OR SW-SM).
- 2.6 COARSE AGGREGATE FOR ACCESS ROAD SUBBASE COURSE SHALL CONFORM TO ASTM D2940.
- 2.7 UNSUITABLE MATERIAL: HIGH AND MODERATELY PLASTIC SILTS AND CLAYS (LL>45), MATERIAL CONTAINING REFUSE, FROZEN LUMPS, DEMOLISHED BITUMINOUS MATERIAL, VEGETATIVE MATTER, WOOD, STONES IN EXCESS OF 3 INCHES IN ANY DIMENSION, AND DEBRIS AS DETERMINED BY THE CONSTRUCTION MANAGER. TYPICAL THESE WILL BE SOILS CLASSIFIED BY ASTM AS PT, MH, CH, OH, ML, AND OL.
- 2.8 GEOTEXTILE FABRIC: MIRAFI 500X OR ENGINEER APPROVED EQUAL.
- 2.9 PLASTIC MARKING TAPE: SHALL BE ACID AND ALKALI RESISTANT POLYETHYLENE FILM SPECIFICALLY MANUFACTURED FOR MARKING AND LOCATING UNDERGROUND UTILITIES. 6 INCHES WIDE WITH A MINIMUM THICKNESS OF 0.004 INCH. TAPE SHALL HAVE MINIMUM STRENGTH OF 1500 PSI IN BOTH DIRECTIONS AND MANUFACTURED WITH INTEGRAL CONDUCTORS. FOIL BACKING OR OTHER MEANS TO ENABLE DETECTION BY A METAL DETECTOR WHEN BURIED UP TO 3 FEET DEEP. THE METALLIC CORE OF THE TAPE SHALL BE ENCASED IN A PROTECTIVE JACKET OR PROVIDED WITH OTHER MEANS TO PROTECT IT FROM CORROSION. TAPE COLOR SHALL BE RED FOR ELECTRIC UTILITIES AND ORANGE FOR TELECOMMUNICATION UTILITIES.

PART 3 - EXECUTION

- 3.1 GENERAL:
- A. BEFORE STARTING GENERAL SITE PREPARATION ACTIVITIES, INSTALL EROSION AND SEDIMENT CONTROL MEASURES. THE WORK AREA SHALL BE CONSTRUCTED AND MAINTAINED IN SUCH CONDITION THAT IN THE EVENT OF RAIN THE SITE WILL BE DRAINED AT ANY TIME.
 - B. BEFORE ALL SURVEY, LAYOUT, STAKING, AND MARKING ESTABLISH AND MAINTAIN ALL LINES, GRADES, ELEVATIONS AND BENCHMARKS NEEDED FOR EXECUTION OF THE WORK.
 - C. CLEAR AND GRUB THE AREA WITHIN THE LIMITS OF THE SITE. REMOVE TREES, BRUSH, STUMPS, RUBBISH AND OTHER DEBRIS AND VEGETATION RESTING ON OR PROTRUDING THROUGH THE SURFACE OF THE SITE AREA TO BE CLEARED.
 - 1. REMOVE THE FOLLOWING MATERIALS TO A DEPTH OF NO LESS THAN 12 INCHES BELOW THE ORIGINAL GROUND SURFACE: ROOTS, STUMPS, AND OTHER DEBRIS, BRUSH, AND REFUSE EMBEDDED IN OR PROTRUDING THROUGH THE GROUND SURFACE, RAKE, DISK OR PLOW THE AREA TO A DEPTH OF NO LESS THAN 6 INCHES, AND REMOVE TO A DEPTH OF 12 INCHES ALL ROOTS AND OTHER DEBRIS THEREBY EXPOSED.
 - 2. REMOVE TOPSOIL MATERIAL COMPLETELY FROM THE SURFACE UNTIL THE SOIL NO LONGER MEETS THE DEFINITION OF TOPSOIL. AVOID MIXING TOPSOIL WITH SUBSOIL OR OTHER UNDESIRABLE MATERIALS.
 - 3. EXCEPT WHERE EXCAVATION TO GREATER DEPTH IS INDICATED, FILL DEPRESSIONS RESULTING FROM CLEARING, GRUBBING AND DEMOLITION WORK COMPLETELY WITH SUITABLE FILL.
 - D. REMOVE FROM THE SITE AND DISPOSE IN AN AUTHORIZED LANDFILL ALL DEBRIS RESULTING FROM CLEARING AND GRUBBING OPERATIONS. BURNING WILL NOT BE PERMITTED.
 - E. PRIOR TO EXCAVATING, THOROUGHLY EXAMINE THE AREA TO BE EXCAVATED AND/OR TRENCHED TO VERIFY THE LOCATIONS OF FEATURES INDICATED ON THE DRAWINGS AND TO ASCERTAIN THE EXISTENCE AND LOCATION OF ANY STRUCTURE, UNDERGROUND STRUCTURE, OR OTHER ITEM NOT SHOWN THAT MIGHT INTERFERE WITH THE PROPOSED CONSTRUCTION. NOTIFY THE CONSTRUCTION MANAGER OF ANY OBSTRUCTIONS THAT WILL PREVENT ACCOMPLISHMENT OF THE WORK AS INDICATED ON THE DRAWINGS.
 - F. SEPARATE AND STOCK PILE ALL EXCAVATED MATERIALS SUITABLE FOR BACKFILL. ALL EXCESS EXCAVATED AND UNSUITABLE

MATERIALS SHALL BE DISPOSED OF OFF-SITE IN A LEGAL MANNER.

- 3.2 BACKFILL:
- A. AS SOON AS PRACTICAL, AFTER COMPLETING CONSTRUCTION OF THE RELATED STRUCTURE, INCLUDING EXPIRATION OF THE SPECIFIED MINIMUM CURING PERIOD FOR CAST-IN-PLACE CONCRETE, BACKFILL THE EXCAVATION WITH APPROVED MATERIAL TO RESTORE THE REQUIRED FINISHED GRADE.
 - 1. PRIOR TO PLACING BACKFILL AROUND STRUCTURES, ALL FORMS SHALL BE REMOVED AND THE EXCAVATION CLEANED OF ALL TRASH, DEBRIS, AND UNSUITABLE MATERIALS.
 - 2. BACKFILL BY PLACING AND COMPACTING SUITABLE BACKFILL MATERIAL OR SELECT GRANULAR BACKFILL MATERIAL WHEN REQUIRED IN UNIFORM HORIZONTAL LAYERS OF NO GREATER THAN 8 INCHES LOOSE THICKNESS AND COMPACTED. WHERE HAND OPERATED COMPACTORS ARE USED, THE FILL MATERIAL SHALL BE PLACED IN LIFTS NOT TO EXCEED 4 INCHES IN LOOSE DEPTH AND COMPACTED.
 - 3. WHENEVER THE DENSITY TESTING INDICATES THAT THE CONTRACTOR HAS NOT OBTAINED THE SPECIFIED DENSITY, THE SUCCEEDING LAYER SHALL NOT BE PLACED UNTIL THE SPECIFICATION REQUIREMENTS ARE MET UNLESS OTHERWISE AUTHORIZED BY THE GEOTECHNICAL ENGINEER. THE CONTRACTOR SHALL TAKE WHATEVER APPROPRIATE ACTION IS NECESSARY, SUCH AS DISKING AND DRYING, ADDING WATER, OR INCREASING THE COMPACTIVE EFFORT TO MEET THE MINIMUM COMPACTION REQUIREMENTS.
 - B. THOROUGHLY COMPACT EACH LAYER OF BACKFILL TO A MINIMUM OF 95% OF THE MAXIMUM DRY DENSITY AS PROVIDED BY THE STANDARD PROCTOR TEST, ASTM D 698.
- 3.3 TRENCH EXCAVATION:
- A. UTILITY TRENCHES SHALL BE EXCAVATED TO THE LINES AND GRADES SHOWN ON THE DRAWINGS OR AS DIRECTED BY THE GENERAL CONTRACTOR. PROVIDE SHORING, SHEETING AND BRACING AS REQUIRED TO PREVENT CAVING OR SLOUGHING OF THE TRENCH WALLS.
 - B. EXTEND THE TRENCH WIDTH A MINIMUM OF 6 INCHES BEYOND THE OUTSIDE EDGE OF THE OUTERMOST CONDUIT.
 - C. WHEN SOFT YIELDING, OR OTHERWISE UNSTABLE SOIL CONDITIONS ARE ENCOUNTERED, BACKFILL AT THE REQUIRED TRENCH TO A DEPTH OF NO LESS THAN 12 INCHES BELOW THE REQUIRED ELEVATION AND BACKFILL WITH GRANULAR BEDDING MATERIAL.
- 3.4 TRENCH BACKFILL:
- A. PROVIDE GRANULAR BEDDING MATERIAL IN ACCORDANCE WITH THE DRAWINGS AND THE UTILITY REQUIREMENTS.
 - B. NOTIFY THE GENERAL CONTRACTOR 24 HOURS IN ADVANCE OF BACKFILLING.
 - C. CONDUCT UTILITY CHECK TESTS BEFORE BACKFILLING. BACKFILL AND COMPACT TRENCH BEFORE ACCEPTANCE TESTING.
 - D. PLACE GRANULAR TRENCH BACKFILL UNIFORMLY ON BOTH SIDES OF THE CONDUITS IN 6 INCH UNCOMPACTED LIFTS UNTIL 12 INCHES OVER THE CONDUITS. SOLIDLY RAM AND TAMP BACKFILL INTO SPACE AROUND CONDUITS.
 - E. PROTECT CONDUIT FROM LATERAL MOVEMENT, IMPACT DAMAGE, OR UNBALANCED LOADING.
 - F. ABOVE THE CONDUIT EMBEDMENT ZONE, PLACE AND COMPACT SATISFACTORY BACKFILL MATERIAL IN 8 INCH MAXIMUM LOOSE THICKNESS LIFTS TO RESTORE THE REQUIRED FINISHED SURFACE GRADE.
 - G. COMPACT FINAL TRENCH BACKFILL TO A DENSITY EQUAL TO OR GREATER THAN THAT OF THE EXISTING UNDISTURBED MATERIAL IMMEDIATELY ADJACENT TO THE TRENCH BUT NO LESS THAN A MINIMUM OF 95% OF THE MAXIMUM DRY DENSITY AS PROVIDED BY THE STANDARD PROCTOR TEST, ASTM D 698.
- 3.5 AGGREGATE ACCESS ROAD:
- A. CLEAR, GRUB, STRIP AND EXCAVATE FOR THE ACCESS ROAD TO THE LINES AND GRADES INDICATED ON THE DRAWINGS. SCARIFY TO A DEPTH OF 6 INCHES AND PROOF-ROLL. ALL HOLES, RUTS, SOFT PLACES AND OTHER DEFECTS SHALL BE CORRECTED.
 - B. THE ENTIRE SUBGRADE SHALL BE COMPACTED TO NOT LESS THAN 95 PERCENT OF THE MAXIMUM DRY DENSITY AS PROVIDED BY THE MODIFIED PROCTOR TEST, ASTM D 1557.
 - C. AFTER PREPARATION OF THE SUBGRADE IS COMPLETE THE GEOTEXTILE FABRIC (MIRAFI 500X) SHALL BE INSTALLED TO THE LIMITS INDICATED ON THE DRAWINGS BY ROLLING THE FABRIC OUT LONGITUDINALLY ALONG THE ROADWAY. THE FABRIC SHALL NOT BE DRAGGED ACROSS THE SUBGRADE. PLACE THE ENTIRE ROLL IN A SINGLE OPERATION, ROLLING OUT AS SMOOTHLY AS POSSIBLE.
 - 1. OVERLAPS PARALLEL TO THE ROADWAY WILL BE PERMITTED AT THE CENTERLINE AND AT LOCATIONS BEYOND THE ROADWAY SURFACE WIDTH (I.E. WITHIN THE SHOULDER WIDTH) ONLY. NO LONGITUDINAL OVERLAPS SHALL BE LOCATED BETWEEN THE CENTERLINE AND THE SHOULDER. PARALLEL OVERLAPS SHALL BE A MINIMUM OF 3 FEET WIDE.
 - 2. TRANSVERSE (PERPENDICULAR TO THE ROADWAY) OVERLAPS AT THE END OF A ROLL SHALL OVERLAP IN THE DIRECTION OF THE AGGREGATE PLACEMENT (PREVIOUS ROLL ON TOP) AND SHALL HAVE A MINIMUM LENGTH OF 3 FEET.
 - 3. ALL OVERLAPS SHALL BE PINNED WITH STAPLES OR NAILS A MINIMUM OF 10 INCHES LONG TO INSURE POSITIONING DURING PLACEMENT OF AGGREGATE. PIN LONGITUDINAL SEAMS AT 25 FOOT CENTERS AND TRANSVERSE SEAMS EVERY 5 FEET.
 - D. AGGREGATE TO BE PLACED ON GEOTEXTILE FABRIC SHALL BE END-DUMPED ON THE FABRIC FROM THE FREE END OF THE FABRIC OR OVER PREVIOUSLY PLACED AGGREGATE. THE FIRST LIFT SHALL BE BLADED DOWN TO A THICKNESS OF 6 INCHES PRIOR TO COMPACTION. AT NO TIME SHALL EQUIPMENT, EITHER TRANSPORTING THE AGGREGATE OR GRADING THE AGGREGATE, BE PERMITTED ON THE ROADWAY WITH LESS THAN 4 INCHES OF MATERIAL COVERING THE FABRIC.
 - E. THE AGGREGATE SHALL BE IMMEDIATELY COMPACTED TO NOT LESS THAN 95 PERCENT OF THE MAXIMUM DRY DENSITY AS PROVIDED BY THE MODIFIED PROCTOR TEST, ASTM D 1557 WITH A TAMPING ROLLER, OR WITH A PNEUMATIC-TIRED ROLLER, OR WITH A VIBRATORY MACHINE OR ANY COMBINATION OF THE ABOVE. THE TOP LAYER SHALL BE GIVEN A FINAL ROLLING WITH A THREE-WHEEL OR TANDEM ROLLER.
- 3.6 FINISH GRADING:
- A. PERFORM ALL GRADING TO PROVIDE POSITIVE DRAINAGE AWAY FROM STRUCTURES AND SMOOTH, EVEN SURFACE DRAINAGE OF THE ENTIRE AREA WITHIN THE LIMITS OF CONSTRUCTION. GRADING SHALL BE COMPATIBLE WITH ALL SURROUNDING TOPOGRAPHY AND STRUCTURES.
 - B. UTILIZE SATISFACTORY FILL MATERIAL RESULTING FROM THE EXCAVATION WORK IN THE CONSTRUCTION OF FILLS, EMBANKMENTS AND FOR REPLACEMENT OF REMOVED UNSUITABLE MATERIALS.
 - C. ACHIEVE FINISHED GRADE BY PLACING A MINIMUM OF 4 INCHES OF 1/2" - 3/4" CRUSHED STONE ON TOP SOIL STABILIZER FABRIC.
 - D. REPAIR ALL ACCESS ROADS AND SURROUNDING AREAS USED DURING THE COURSE OF THIS WORK TO THEIR ORIGINAL CONDITION.
- 3.7 ASPHALT PAVING ROAD:
- A. SECTION 400 - ODOT FLEXIBLE PAVEMENT.
 - B. SECTION 400 - PennDOT BITUMINOUS CONCRETE COURSES.
 - C. DIVISION 400 - WVDOT BITUMINOUS PAVEMENTS.
 - D. SECTION 400 - INDOT ASPHALT PAVEMENTS
 - E. SECTION 1000 - KYTC ASPHALT PAVEMENTS

CONTRACTOR'S WORK SHALL COMPLY WITH ALL APPLICABLE NATIONAL, STATE, AND LOCAL CODES AS ADOPTED BY THE LOCAL AUTHORITY HAVING JURISDICTION (AHJ) FOR THE LOCATION. THE EDITION OF THE AHJ ADOPTED CODES AND STANDARDS IN EFFECT ON THE DATE OF CONTRACT AWARD SHALL GOVERN THE DESIGN.

BUILDING CODES:
 OHIO BUILDING CODE (OBC 2024, IBC 2021), LATEST EDITION ADOPTED BY STATE OF OHIO
 ALSO BY LOCAL JURISDICTION BUILDING AUTHORITY,
 OHIO PLUMBING CODE (OPC 2024),
 OHIO MECHANICAL CODE (OMC 2024),
 NATIONAL ELECTRICAL CODE (NEC 2023), LATEST EDITION AS ADOPTED BY LOCAL BUILDING AUTHORITY AND BY STATE OF OHIO,
 NFPA 70 - NATIONAL FIRE PROTECTION ASSOCIATION (NFPA) - (2023 EDITION),
 NFPA 101 - LIFE SAFETY CODE - (2021 EDITION),
 NFPA 780 - LIGHTNING PROTECTION SYSTEMS - (2020 EDITION)

CONTRACTOR'S WORK SHALL COMPLY WITH THE LATEST EDITION OF THE FOLLOWING STANDARDS:
 AMERICAN CONCRETE INSTITUTE (ACI) 318-19, BUILDING CODE REQUIREMENTS FOR STRUCTURAL CONCRETE & COMMENTARY
 AMERICAN INSTITUTE OF STEEL CONSTRUCTION (AISC), STEEL CONSTRUCTION MANUAL, FIFTEENTH EDITION
 TELECOMMUNICATIONS INDUSTRY ASSOCIATION (TIA) 222-H, STRUCTURAL STANDARDS FOR STEEL ANTENNA TOWER AND ANTENNA SUPPORTING STRUCTURES:
 TIA 607, COMMERCIAL BUILDING GROUNDING AND BONDING REQUIREMENTS FOR TELECOMMUNICATIONS

INSTITUTE FOR ELECTRICAL AND ELECTRONICS ENGINEERS (IEEE) 81, GUIDE FOR MEASURING EARTH RESISTIVITY, GROUND IMPEDANCE, AND EARTH SURFACE POTENTIALS OF A GROUND SYSTEM
 IEEE 1100 (LATEST EDITION) RECOMMENDED PRACTICE FOR POWERING AND GROUNDING OF ELECTRONIC EQUIPMENT

IEEE C62.41, RECOMMENDED PRACTICES ON SURGE VOLTAGES IN LOW VOLTAGE AC POWER CIRCUITS (FOR LOCATION CATEGORY "C3" AND "HIGH SYSTEM EXPOSURE")

TELCORDIA GR-1275, GENERAL INSTALLATION REQUIREMENTS

TELCORDIA GR-1503, COAXIAL CABLE CONNECTIONS

ANSI T1.311, FOR TELECOM - DC POWER SYSTEMS - TELECOM, ENVIRONMENTAL PROTECTION

FOR ANY CONFLICTS BETWEEN SECTIONS OF LISTED CODES AND STANDARDS REGARDING MATERIAL, METHODS OF CONSTRUCTION, OR OTHER REQUIREMENTS, THE MOST RESTRICTIVE REQUIREMENT SHALL GOVERN. WHERE THERE IS CONFLICT BETWEEN A GENERAL REQUIREMENT AND A SPECIFIC REQUIREMENT, THE SPECIFIC REQUIREMENT SHALL GOVERN.

CODE COMPLIANCE:

GOVERNING CODE: TIA-222-H
 RISK CATEGORY: I
 SEISMIC VALUES: S1 = X.XXX SS = X.XXX
 EXPOSURE CATEGORY: C
 TOPOGRAPHIC CATEGORY: 1
 ULTIMATE DESIGN WIND SPEED: 115 MPH
 NOMINAL DESIGN WIND SPEED: 90 MPH
 SEISMIC DESIGN CATEGORY: B
 SEISMIC SITE CLASS: D



GPD JOB #:	2025705.79
DRAWN BY:	ACM
CHECKED BY:	LJB
RFDS:	25309

REV	DATE	DESCRIPTION
0	08/27/2025	FOR CONSTRUCTION
C	08/15/2025	REV. PER COMMENTS
B	08/12/2025	REV. PER COMMENTS
A	06/05/2025	ISSUED FOR REVIEW

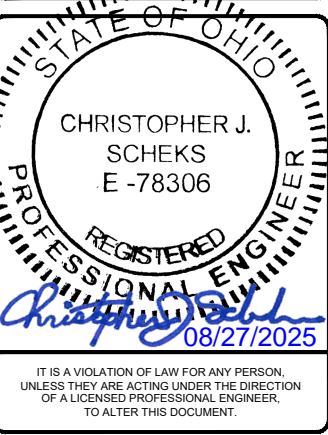

SHANNON PARK
 SOH3625
 6790 COFFMAN RD
 DUBLIN, OH 43017
 COLOCATION

SHEET TITLE
 GENERAL CONSTRUCTION NOTES

SHEET NUMBER
GN-3