



MCDONALD'S REMODEL - SIGNAGE PACKAGE

6830 PERIMETER LOOP RD.,

DUBLIN, OH 43017

SUBMITTED TO:

CITY OF DUBLIN – PLANNING DEPARTMENT

5800 SHIER RINGS RD.,

DUBLIN, OH 43016

PERMIT SOLUTIONS POINT OF CONTACT:

REBECCA GREEN

614-496-4220

[RGREEN@PERMITSOLUTIONSOHIO.COM](mailto:RGREEN@PERMITSOLUTIONSOHIO.COM)

175 S THIRD ST., SUITE 170

COLUMBUS, OH 43212

# SECTION 1

## SITE PLAN WITH SIGN LOCATIONS

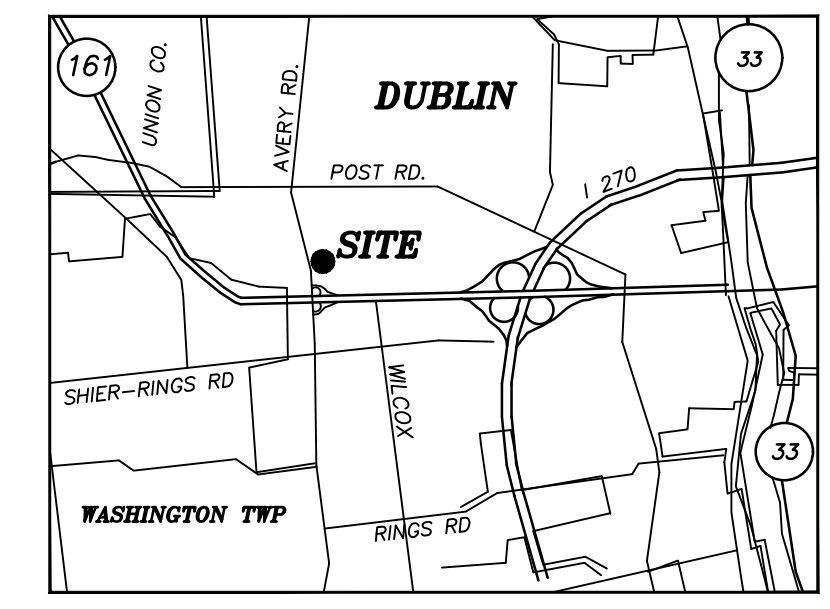

LOCATION MAP  
NOT TO SCALE

REV	DATE	DESCRIPTION
X	X	X
X	X	X
X	X	X

BY	DATE	DESCRIPTION
X	X	X
X	X	X
X	X	X

SiteSource Consultants, Inc.  
4254 Tuller Road • Dublin, Ohio 43017  
Phone: 614-718-9633 • Fax: 614-761-0717  
Email: sitesource@ameritech.net

L/C # 34-1321

**McDonald's**  
PROPOSED McDONALD'S RESTAURANT REMODEL AT:  
6830 PERIMETER LOOP ROAD  
DUBLIN, OHIO

JOB NO. SS017-537

DATE: APRIL 2018

SITE PLAN

SHEET: C1

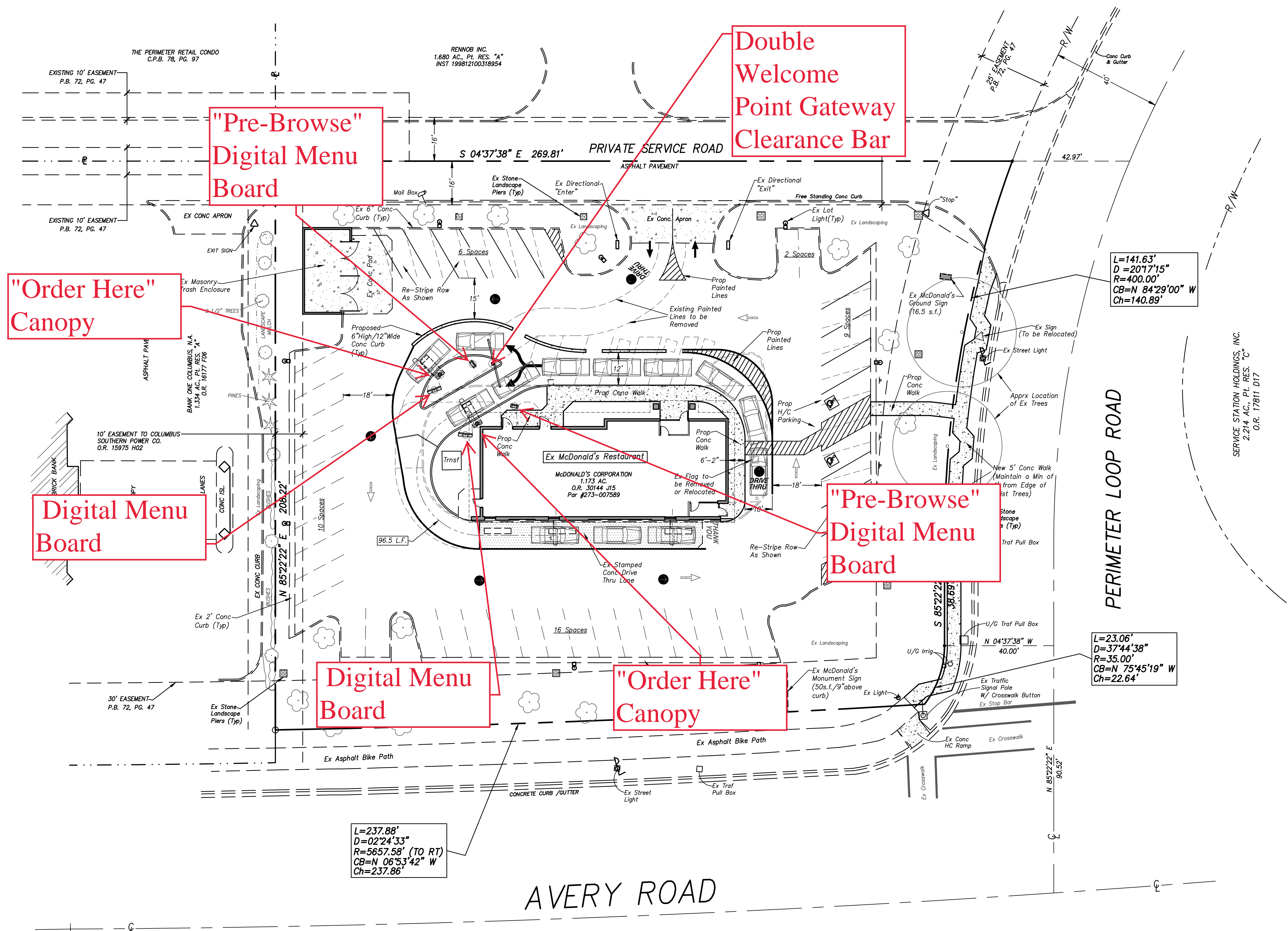

**SITE SUMMARY**

EXISTING ZONING: PCD (PLANNED COMMERCE DISTRICT)  
USE: RESTAURANT W/ DRIVE THRU

**SETBACKS:**  
FRONT SETBACK: 50'  
SIDE SETBACKS: 50'

**BUILDING SIZE:**  
EXISTING BUILDING 3,219 S.F.  
PROPOSED ADDITIONS 0 S.F.  
TOTAL 3,219 S.F.

**PARKING**  
EXISTING NUMBER OF PARKING SPACES: 53 SPACES  
PROPOSED NUMBER OF PARKING SPACES: 43 SPACES

**AREAS**  
TOTAL SITE AREA: (1.173 ACRES) 51,095.88 S.F. (100%)  
TOTAL EXISTING IMPERVIOUS AREA: 34,168.78 S.F. (67%)  
TOTAL PROPOSED IMPERVIOUS AREA: 35,091.32 S.F. (69%)

**PRELIMINARY SITE PLAN**  
APRIL 3, 2018

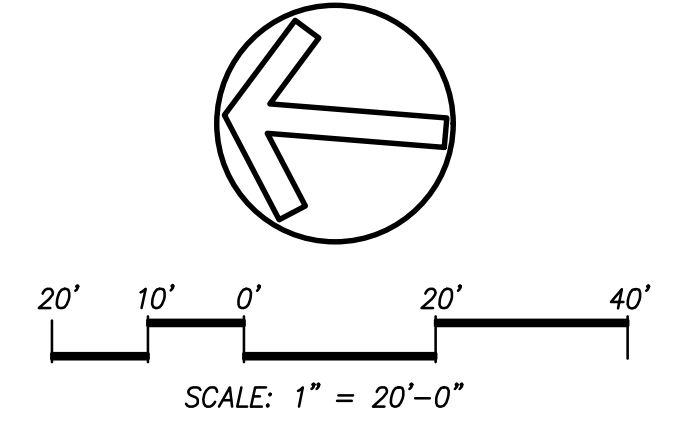

## SECTION 2

### DRIVE THRU EQUIPMENT



## SINGLE 55"

Modular Range

Hot-dipped galvanized frame

Aluminum panels

Modular Mounting Structure

Allows for various screen sizes with panel/mount replacement

Option for crane in or manual 2 person assembly

Currently designed for the Samsung OHF panel but mounting hardware can be modified for alternate screen specifications in future

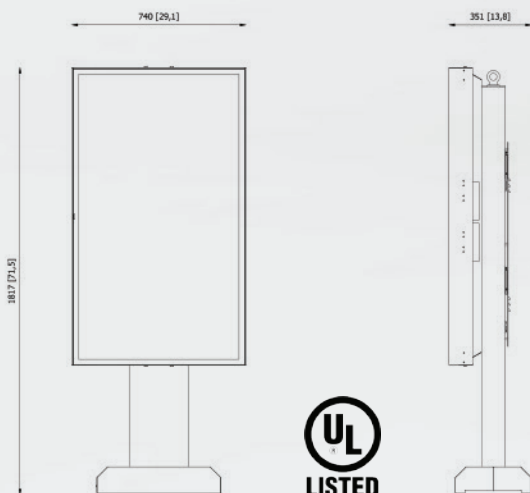

# Coates ODMB

Single screen unit

Area of display

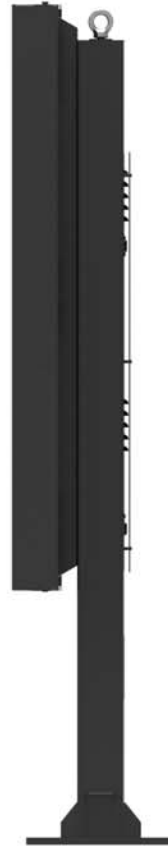
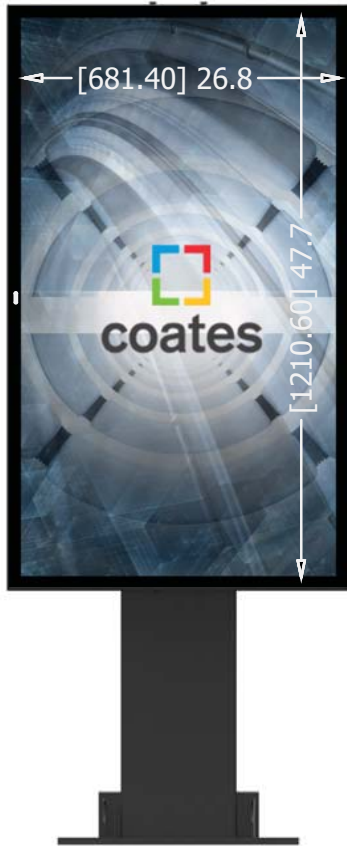

# Coates ODMB

Single screen unit

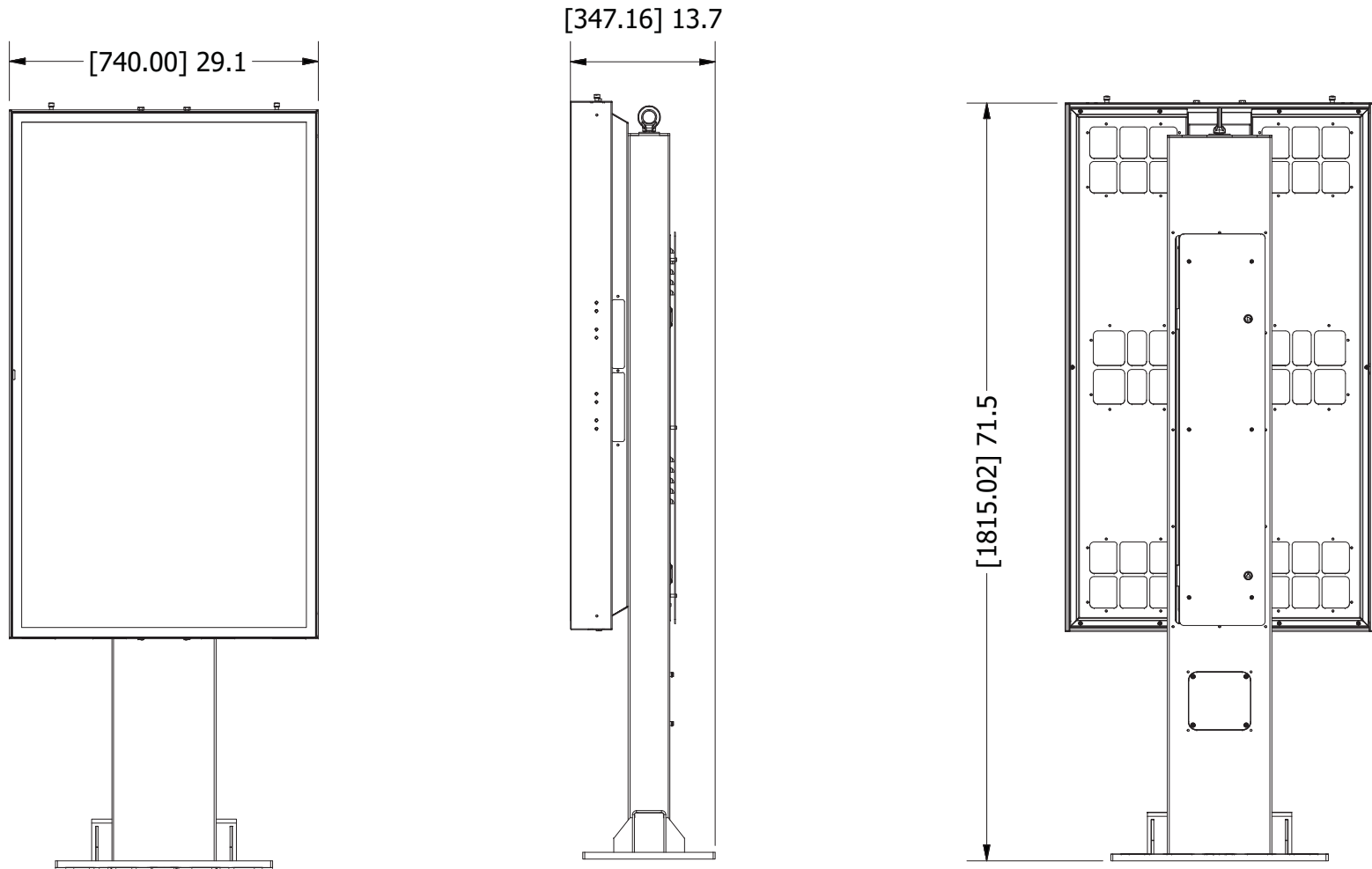



## DOUBLE 55"

Modular Range

Hot-dipped galvanized frame

Aluminum panels

Modular Mounting Structure

Allows for various screen sizes with panel/mount replacement

Option for crane in or manual 2 person assembly

Currently designed for the Samsung OHF panel but mounting hardware can be modified for alternate screen specifications in future

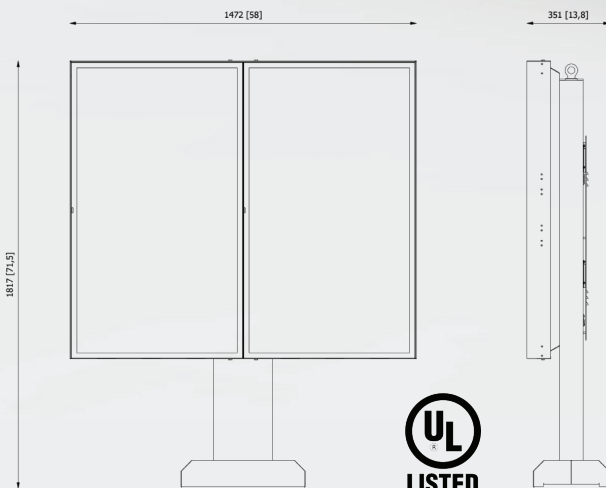



# Coates ODMB

Double screen unit

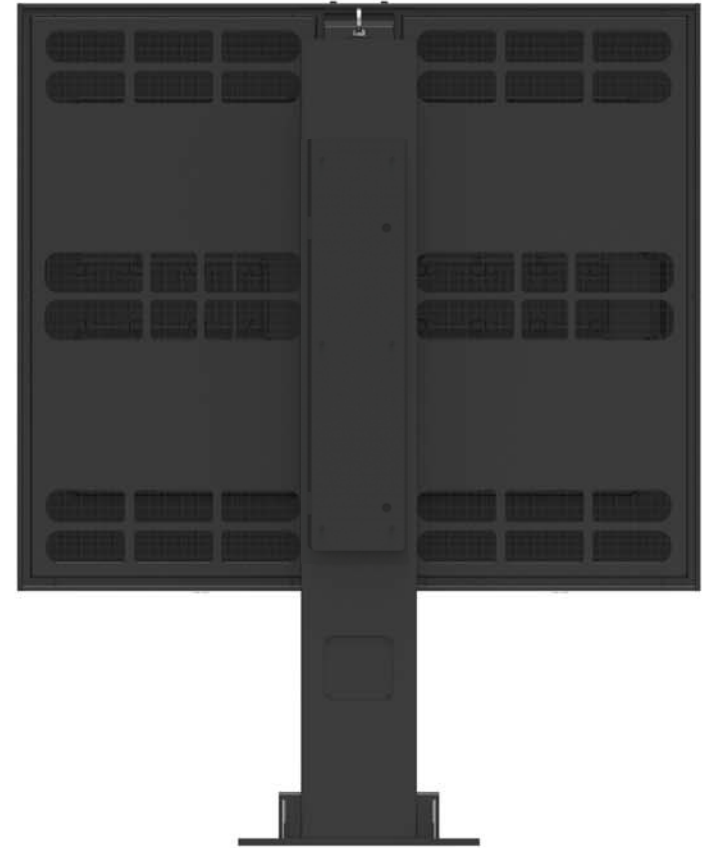

# Coates ODMB

Double screen unit

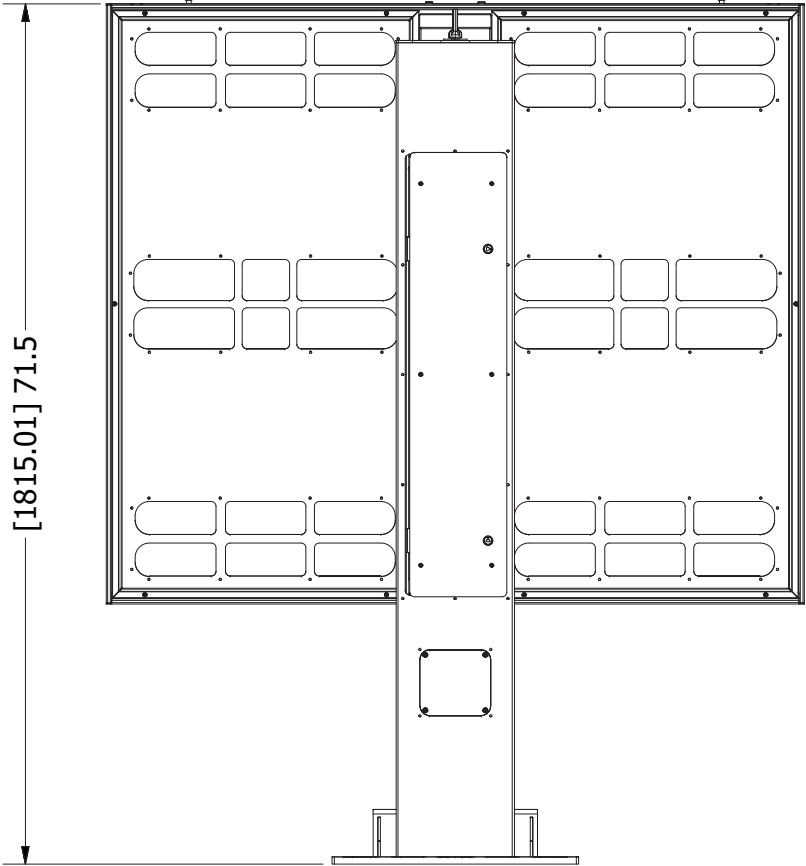
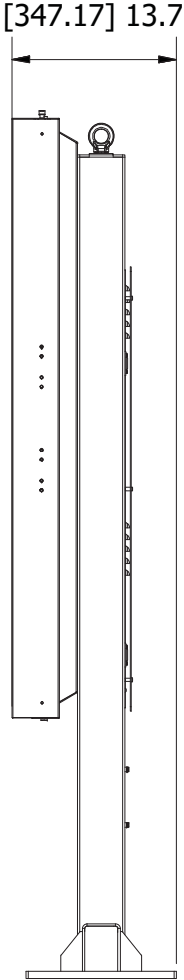
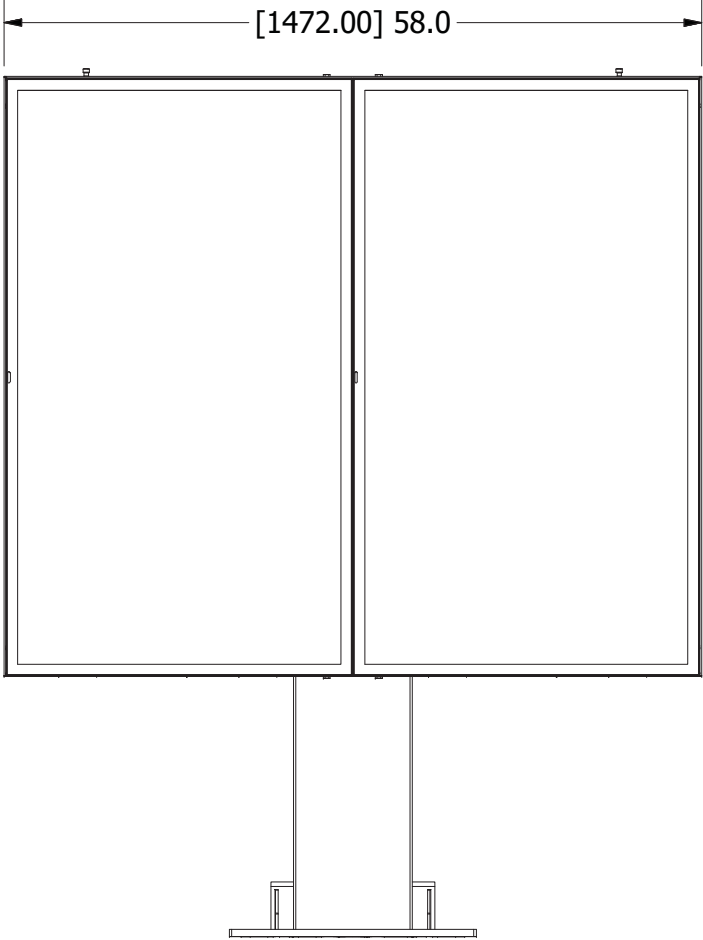

# Springboard Canopy /COD

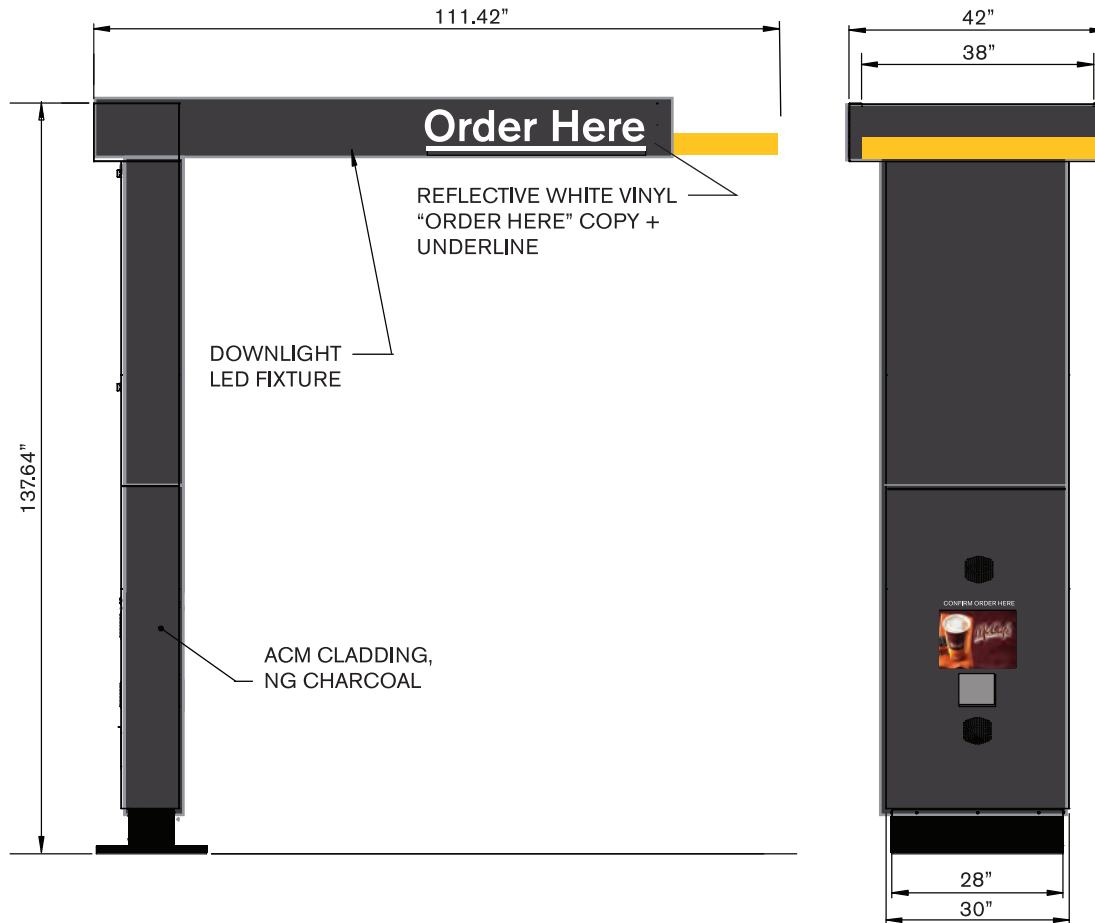

**Illumination:**

**Electrical:**

**Ballast:**

**Ship Weight:**

**Other:**

# Double Welcome Point Gateway



**Illumination:** N/A

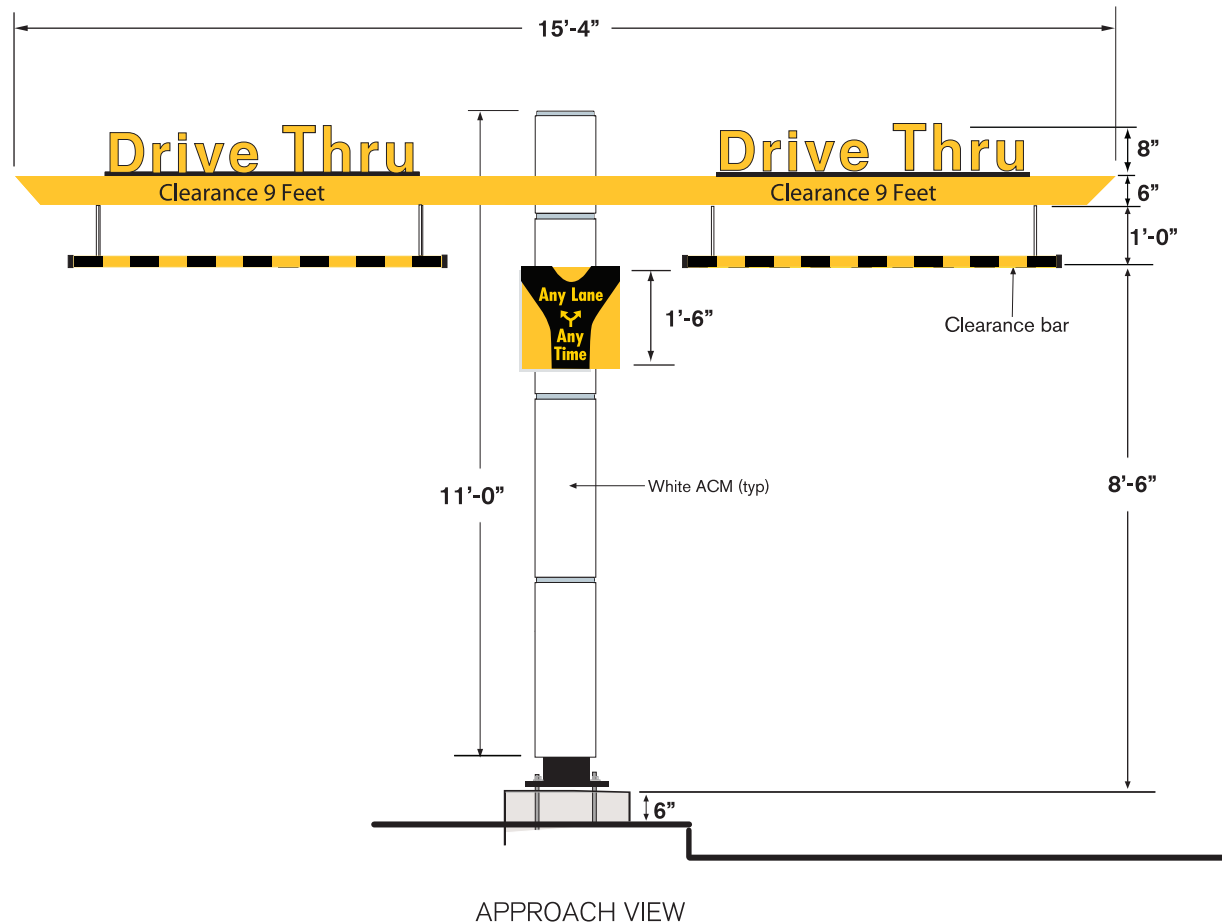

- Other:**
- Non-illuminated clearance sign with spring loaded break away clearance arm.
  - Adjustable bang bar.