

VIEW FROM DUBLIN ROAD (EAST SIDE)



VIEW FROM EBERLY LANE (NORTH SIDE)



VIEW FROM EBERLY LANE (NORTH SIDE)



VIEW FROM EBERLY LANE (NW CORNER)



Revisions:

NO.	DATE

M.J. Design
 ASSOCIATES INC.
 LANDSCAPE DESIGN • BUILD • MAINTENANCE
 www.mjdesignassociates.com
 ADDRESS: 8463 ESTATES CT. 614.873.7333
 PLAIN CITY, OH 43064 614.873.7444

GALBREATH REALTY
 75 S. High Street
 Dublin, OH 43017

Designed By: MICHAEL COYLE
 Drawn By: MICHAEL COYLE
 Approved By: _____
 Date: NOVEMBER 9, 2018

Sheet Title:
 EXISTING
 SITE
 PHOTOS

Scale: NTS

Sheet No.
 P - 1

VIEW FROM EBERLY LANE (NW CORNER)



BACK STEP DETAIL IMAGE (NW CORNER)



BACK STEP DETAIL IMAGE (WEST SIDE)



VIEW OF WEST SIDE (PARKING LOT)



Revisions:

NO.	DATE

M.J. Design
 ASSOCIATES INC.
 LANDSCAPE DESIGN • BUILD • MAINTENANCE
 www.mjdesignassociates.com
 ADDRESS: 8463 ESTATES CT. 614.873.7333
 PLAIN CITY, OH 43064 614.873.7444

GALBREATH REALTY
 75 S. High Street
 Dublin, OH 43017

Designed By: MICHAEL COYLE
 Drawn By: MICHAEL COYLE
 Approved By: _____
 Date: NOVEMBER 9, 2018

Sheet Title:
 EXISTING
 SITE
 PHOTOS

Scale: NTS

Sheet No.
 P - 1.1

Revisions:

DATE	

M.J. Design
 ASSOCIATES INC.
 LANDSCAPE DESIGN • BUILD • MAINTENANCE
 www.mjdesignassociates.com
 ADDRESS: 8463 ESTATES CT. 614.873.7333
 PLAIN CITY, OH 43064 614.873.7444

GALBREATH REAL ESTATE

75 S. High Street
 Dublin, OH 43017

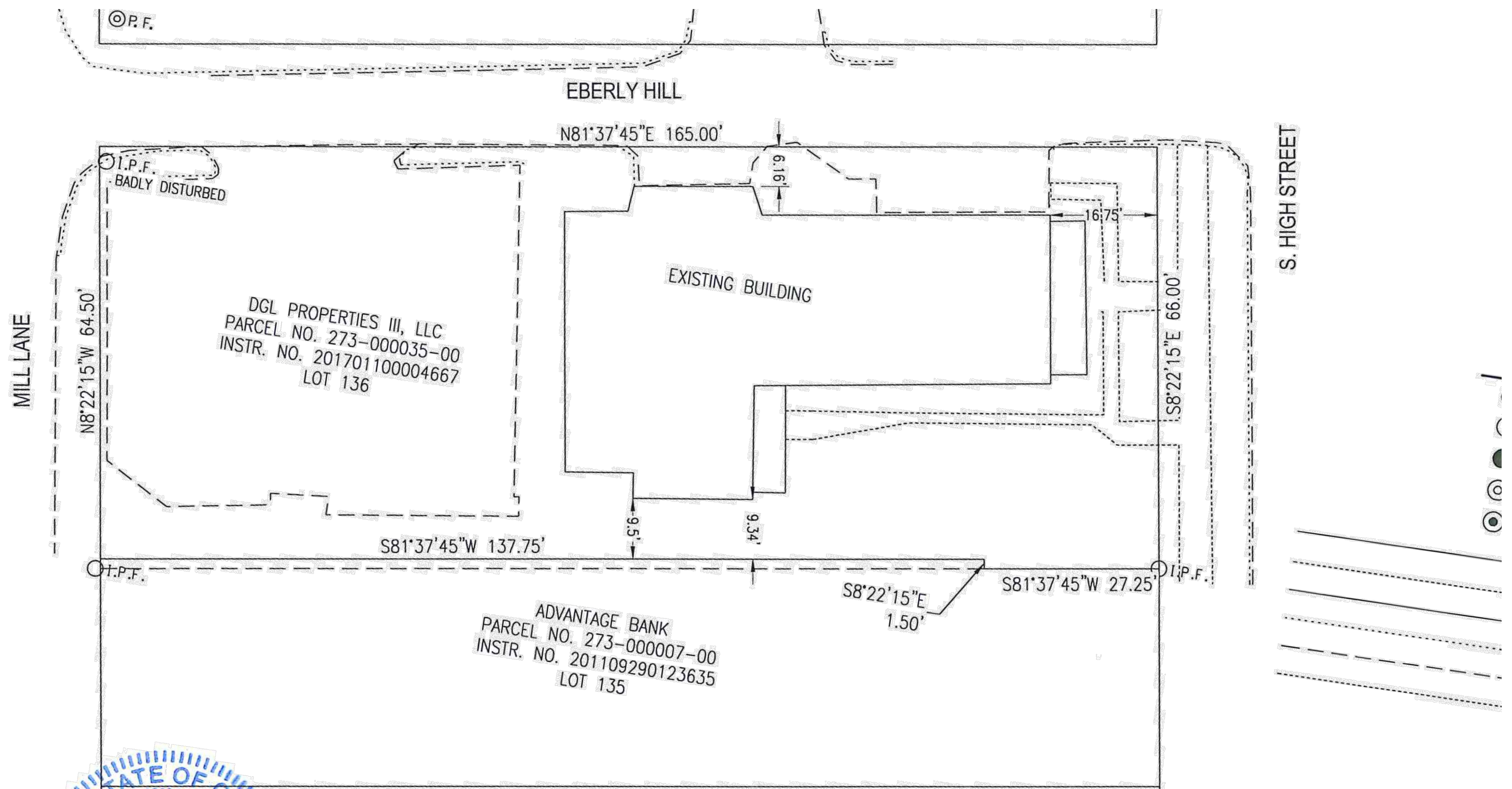

DGL PROPERTIES III, LLC
 PARCEL NO. 273-000035-00
 INSTR. NO. 201701100004667
 LOT 136

ADVANTAGE BANK
 PARCEL NO. 273-000007-00
 INSTR. NO. 201109290123635
 LOT 135

PERTINENT DOCUMENTS USED
 Franklin County Tax Maps
 All Recorded Documents shown
 were used as source documents.

STATE OF OHIO
 JEREMY LEWIS VAN OSTRAN
 8283
 REGISTERED SURVEYOR
 L. VAN OSTRAN P.S. 8283

DRAWN: ---	CHECKED: ---
REVISIONS	DATE

HULL
 Environment / Energy / Infrastructure

Hull & Associates, Inc.
 59 Grant Street
 Newark, OH 43055
 Phone: (740) 344-5451
 Fax: (740) 344-8659
 www.hullinc.com

BOUNDARY SURVEY
 FOR
 75 S. High Street. Dublin

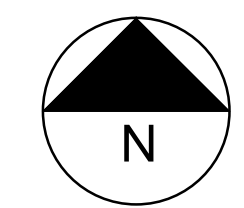

Designed By: MICHAEL COYLE
 Drawn By: MICHAEL COYLE
 Approved By: _____
 Date: NOVEMBER 9, 2018

Sheet Title:
SURVEY

Scale: 1/8" = 1'
 Sheet No.
S-1

Revisions:	DATE
4.4.19	

M.J. Design
 ASSOCIATES INC.
 LANDSCAPE DESIGN • BUILD • MAINTENANCE
 www.mjdesignassociates.com
 ADDRESS: 8463 ESTATES CT. #100 DUBLIN, OH 43064
 PHONE: 614.873.7333 FAX: 614.873.7444

GALBREATH REAL ESTATE
 75 S. High Street
 Dublin, OH 43017

Designed By: MICHAEL COYLE
 Drawn By: MICHAEL COYLE
 Approved By:
 Date: NOVEMBER 9, 2018

Sheet Title:
EXISTING
 Scale: 1/8" = 1'
 Sheet No.
L-1

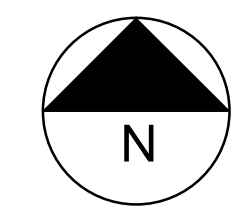
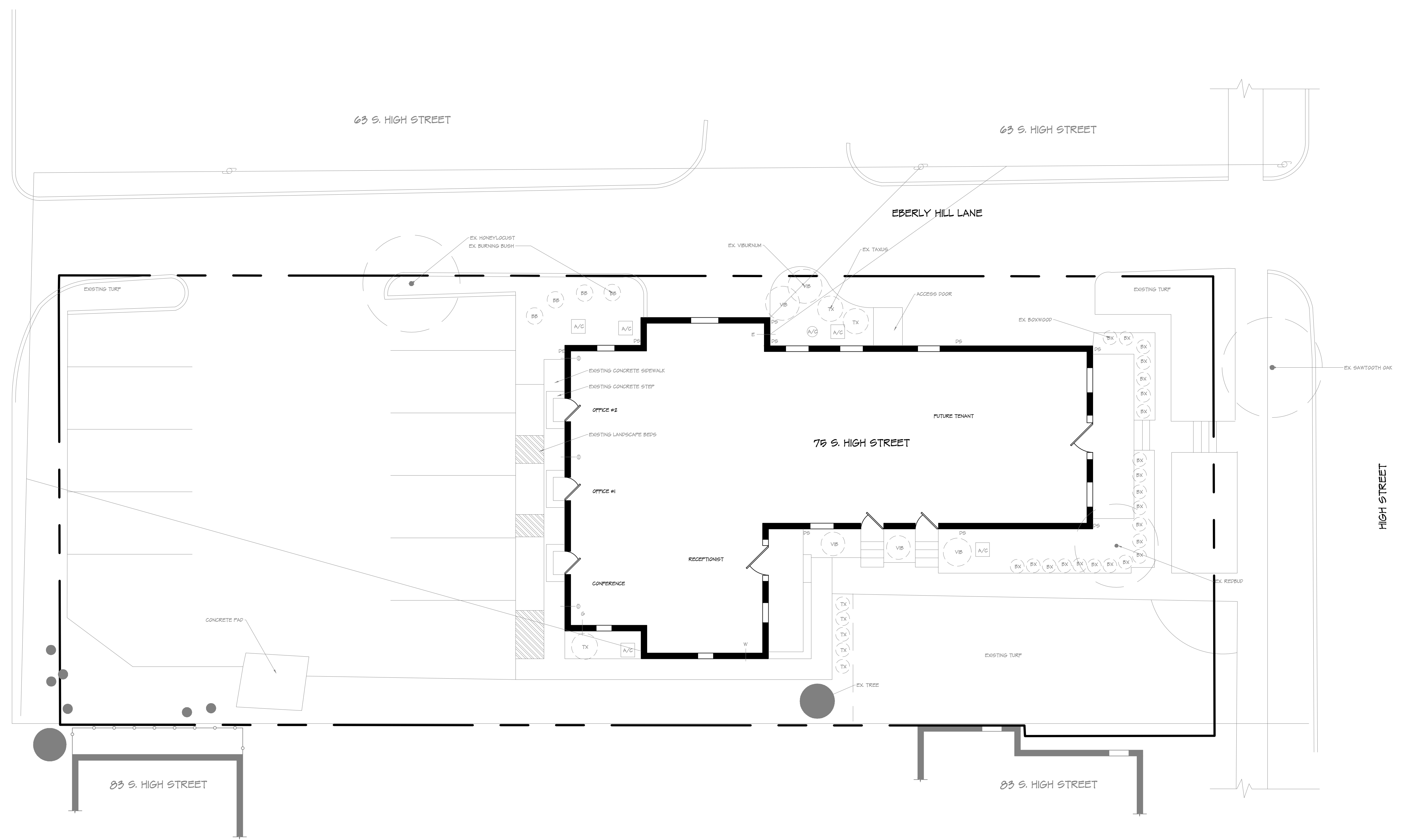

Revisions:	DATE
4.4.19	





M.J. Design
 ASSOCIATES INC.
 LANDSCAPE DESIGN • BUILD • MAINTENANCE
 www.mjdesignassociates.com
 ADDRESS: 8463 ESTATES CT. #104
 PLAIN CITY, OH 43064
 TEL: 614.873.7333
 FAX: 614.873.7444

GALBREATH REAL ESTATE
 75 S. High Street
 Dublin, OH 43017

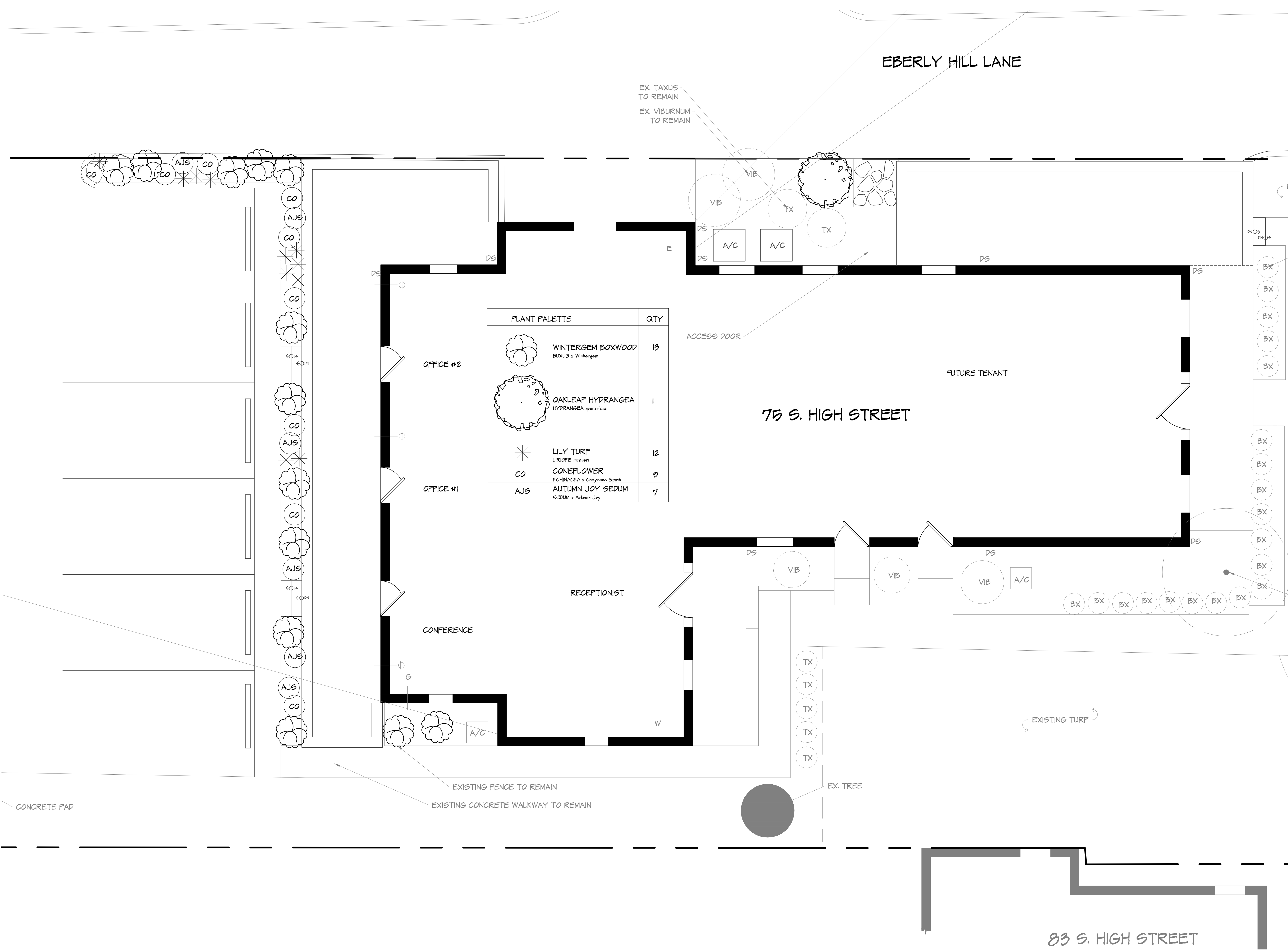
Designed By: MICHAEL COYLE
 Drawn By: MICHAEL COYLE
 Approved By:
 Date: NOVEMBER 9, 2018

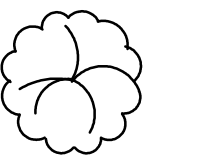
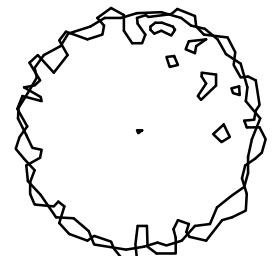
Sheet Title:
PLANTING PLAN
 Scale: 1/4" = 1'
 Sheet No.
L - 3



PLANT PALETTE		QTY
	WINTERGEM BOXWOOD BUXUS x Wintergem	13
	OAKLEAF HYDRANGEA HYDRANGEA quercifolia	1
	LILY TURF LIRIOPE miscan	12
	CONEFLOWER ECHINACEA x Cheyenne Spirit	9
	AUTUMN JOY SEDUM SEDUM x Autumn Jay	7

Revisions:	DATE

M.J. Design
 ASSOCIATES INC.
 LANDSCAPE DESIGN • BUILD • MAINTENANCE
 www.mjdesignassociates.com
 ADDRESS: 8463 ESTATES CT. #1000
 PLAIN CITY, OH 43064 614.873.7333
 614.873.7444

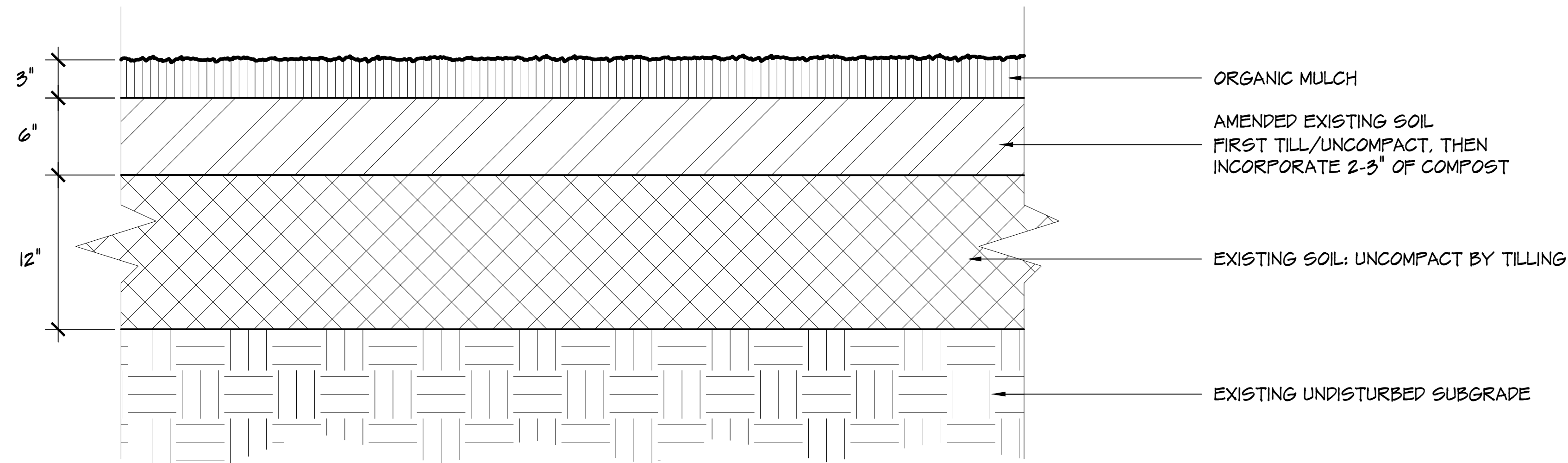

NOTE: GRADE EXISTING SOILS PRIOR TO INSTALLING BLENDED TOPSOIL. SMALL POCKETS OR DIPS MAY HOLD WATER. REMOVE ALL ROCKS AND CONSTRUCTION DEBRIS FROM PLANTING BED.

SOIL AMENDING DETAIL

SCALE: NTS

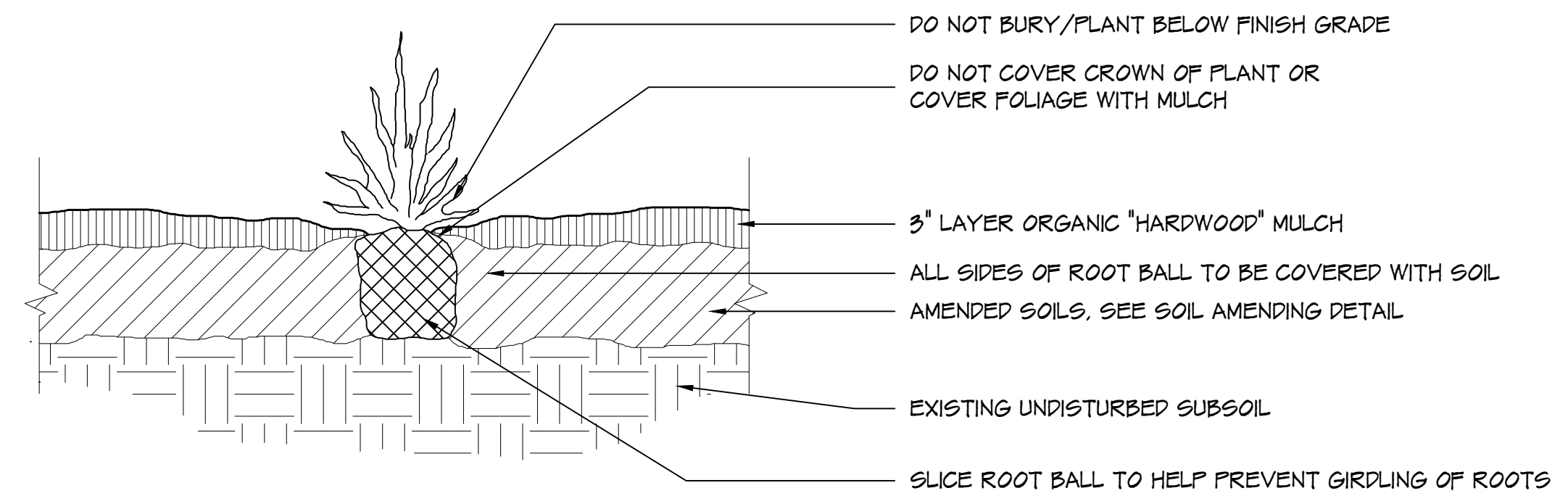

** ALL PLANT MATERIAL TO BE WATERED AND FERTILIZED AT TIME OF PLANTING. ANY PLANTS STOCK PILED ON SITE TO BE WATERED REGULARLY.

PERENNIAL PLANTING DETAIL

SCALE: NTS

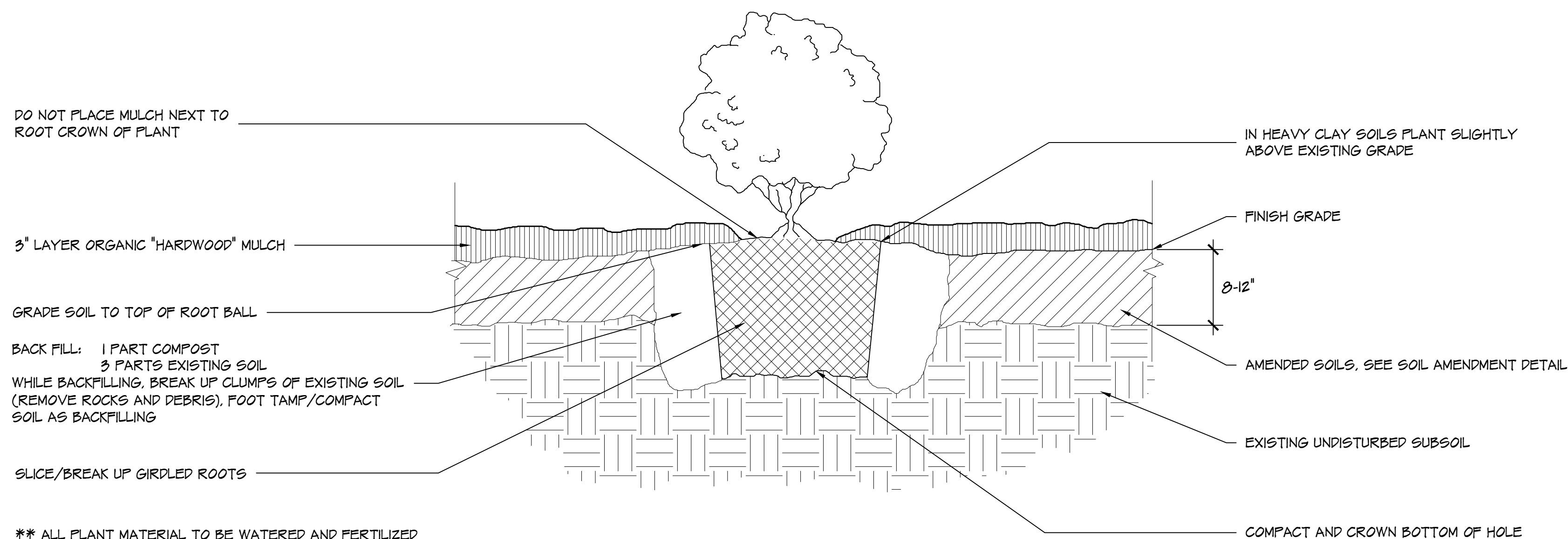

** ALL PLANT MATERIAL TO BE WATERED AND FERTILIZED AT TIME OF PLANTING. ANY PLANTS STOCK PILED ON SITE TO BE WATERED REGULARLY.

SHRUB PLANTING DETAIL

SCALE: NTS

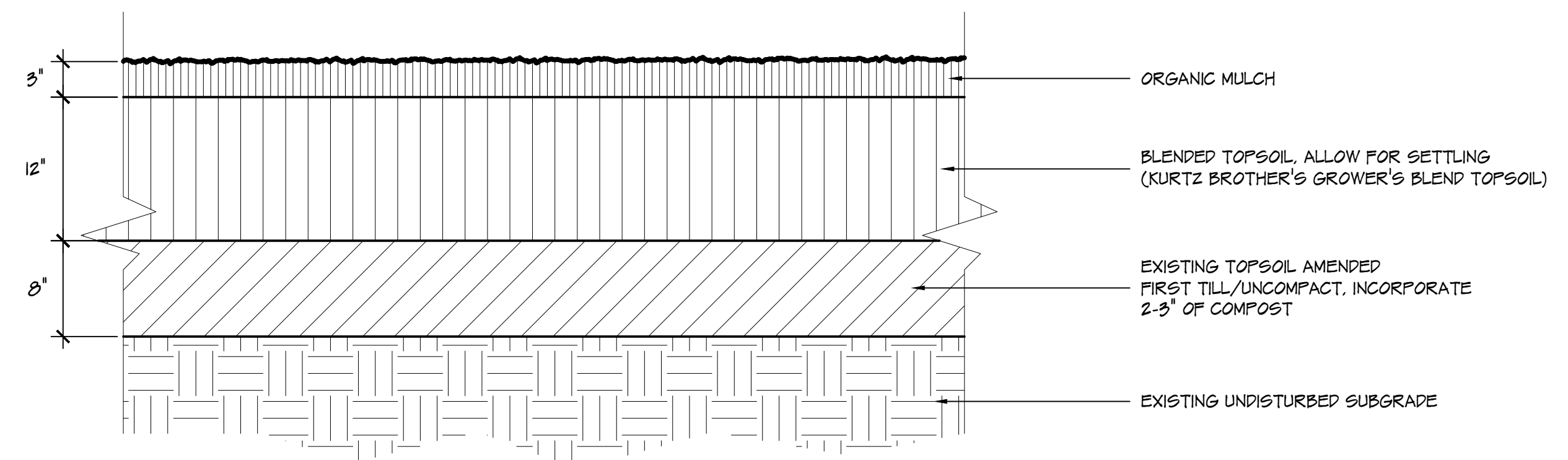

NEW LANDSCAPE BED CONSTRUCTION

SCALE: NTS

GALBREATH REAL ESTATE

75 S. High Street
 Dublin, OH 43017

Designed By: MICHAEL COYLE
 Drawn By: MICHAEL COYLE
 Approved By: _____
 Date: NOVEMBER 9, 2018

Sheet Title:
LANDSCAPE DETAILS

Scale: NTS

Sheet No.
L - 4

Revisions:	DATE
4.4.19	

M.J. Design
 ASSOCIATES INC.
 LANDSCAPE DESIGN • BUILD • MAINTENANCE
 www.mjdesignassociates.com
 ADDRESS: 8463 ESTATES CT. #100 PLAIN CITY, OH 43064
 PHONE: 614.873.7333 FAX: 614.873.7444

GALBREATH REAL ESTATE
 75 S. High Street
 Dublin, OH 43017

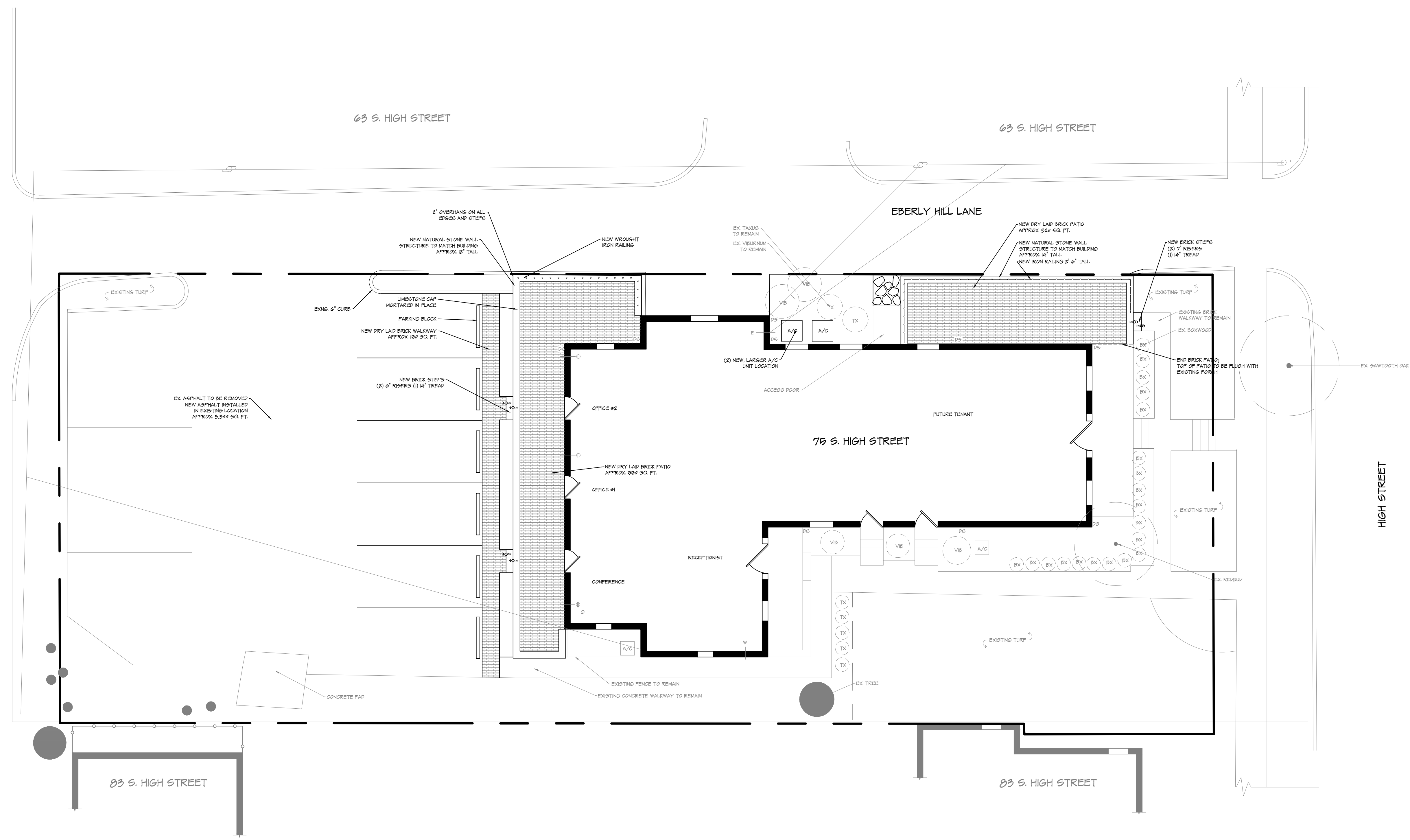

Designed By: MICHAEL COYLE
 Drawn By: MICHAEL COYLE
 Approved By:
 Date: NOVEMBER 9, 2018

Sheet Title:
HARDSCAPE PLAN

Scale: 1/8" = 1'

Sheet No.
L - 5

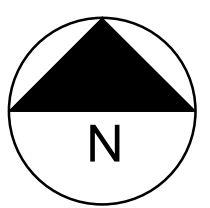

Revisions:	DATE
4.4.19	

M.J. Design
 ASSOCIATES INC.
 LANDSCAPE DESIGN • BUILD • MAINTENANCE
 www.mjdesignassociates.com
 ADDRESS: 8463 ESTATES CT. #100 PLAIN CITY, OH 43064
 PHONE: 614.873.7333 FAX: 614.873.7444

GALBREATH REAL ESTATE
 75 S. High Street
 Dublin, OH 43017

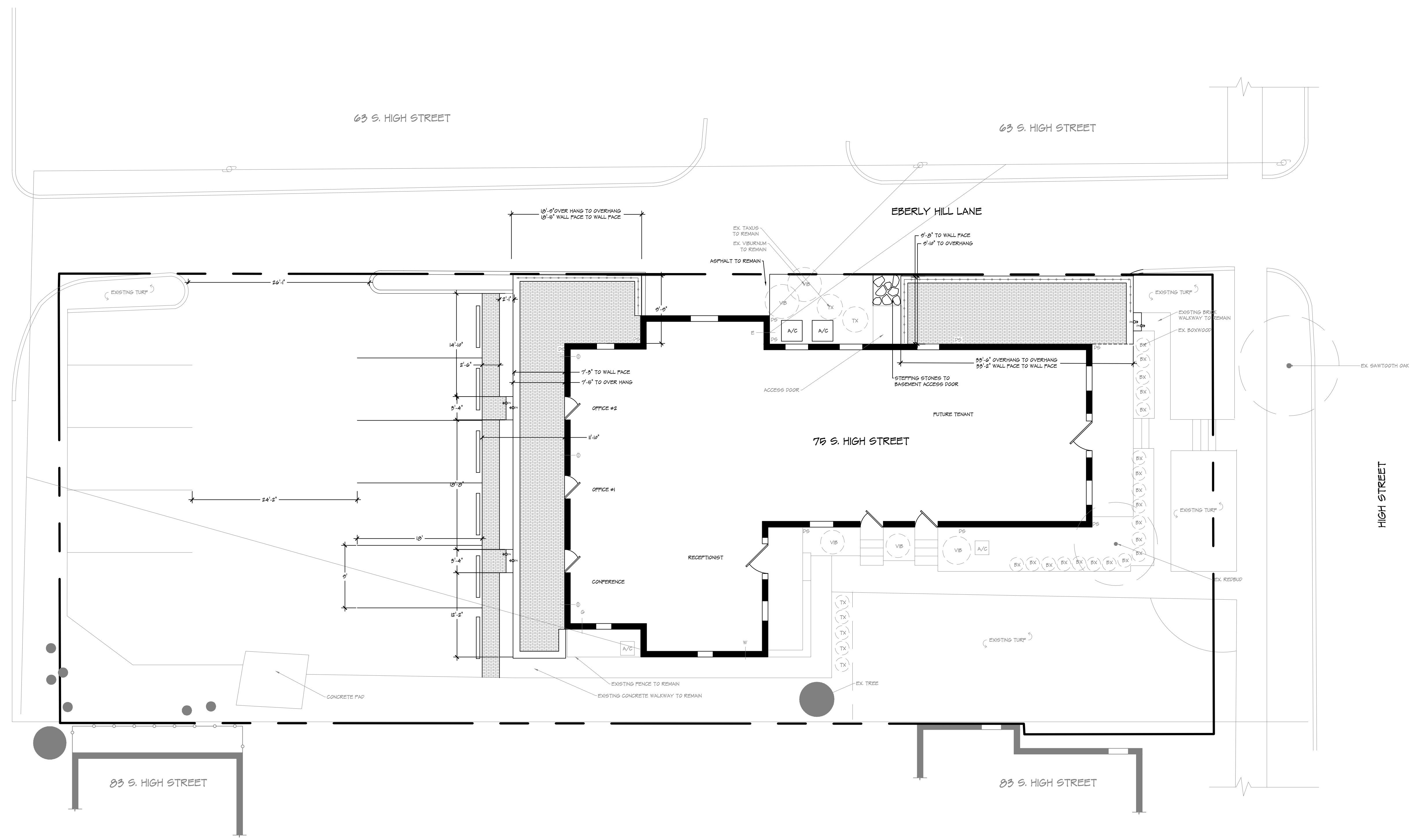

Designed By: MICHAEL COYLE
 Drawn By: MICHAEL COYLE
 Approved By:
 Date: NOVEMBER 9, 2018

Sheet Title:
HARDSCAPE DIMENSIONS

Scale: 1/8" = 1'

Sheet No.
L - 5.1

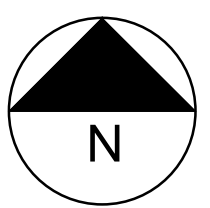

HIGH STREET

63 S. HIGH STREET

EBERLY HILL LANE

75 S. HIGH STREET

Revisions:	DATE
4.4.19	

M.J. Design
 ASSOCIATES INC.
 LANDSCAPE DESIGN • BUILD • MAINTENANCE
 www.mjdesignassociates.com
 ADDRESS: 8463 ESTATES CT. #101 PLAIN CITY, OH 43064
 PHONE: 614.873.7333 FAX: 614.873.7444

GALBREATH REAL ESTATE
 75 S. High Street
 Dublin, OH 43017

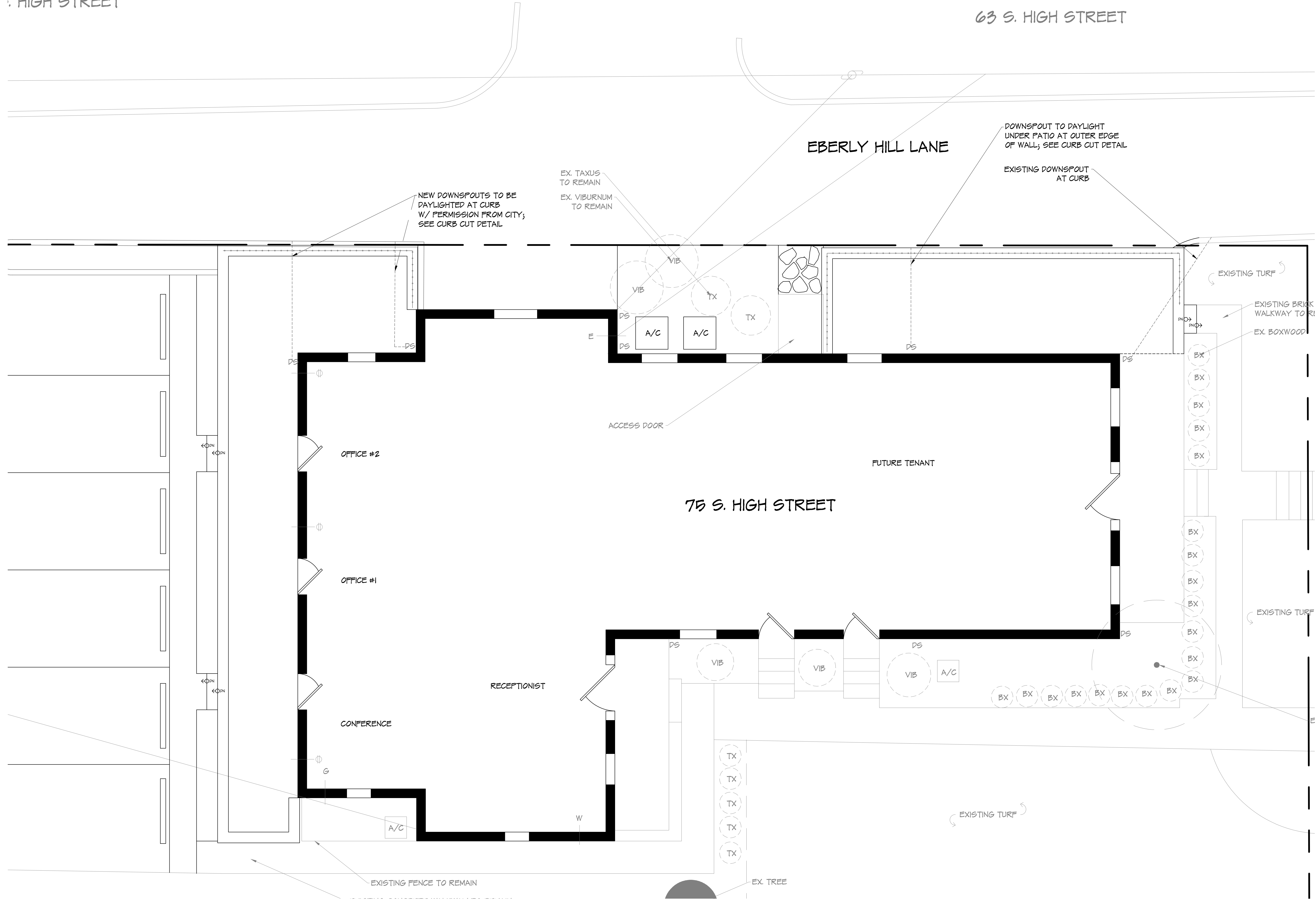

Designed By: MICHAEL COYLE
 Drawn By: MICHAEL COYLE
 Approved By:
 Date: NOVEMBER 9, 2018
 Sheet Title:
DOWNSPOUT PLAN
 Scale: 1/4" = 1'
 Sheet No.
L - 5.2

Revisions:	
DATE	
4.9.19	

M.J. Design
 ASSOCIATES INC.
 LANDSCAPE DESIGN • BUILD • MAINTENANCE
 www.mjdesignassociates.com
 ADDRESS: 8463 ESTATES CT. #104 PLAIN CITY, OH 43064
 PHONE: 614.873.7333 FAX: 614.873.7444

GALBREATH REAL ESTATE
 75 S. High Street
 Dublin, OH 43017

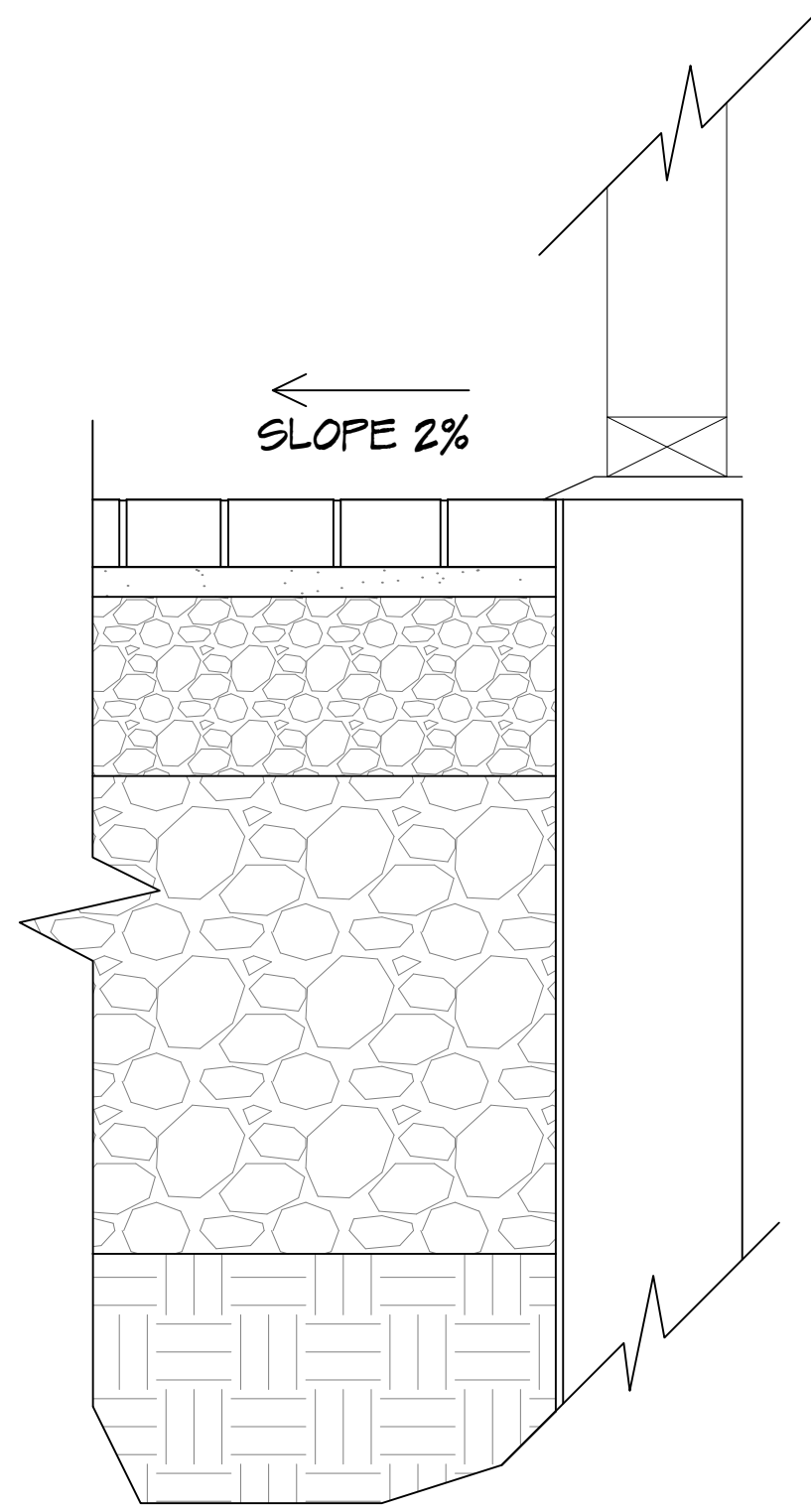

BRICK PATIO DETAIL @ BUILDING
 SCALE: NTS

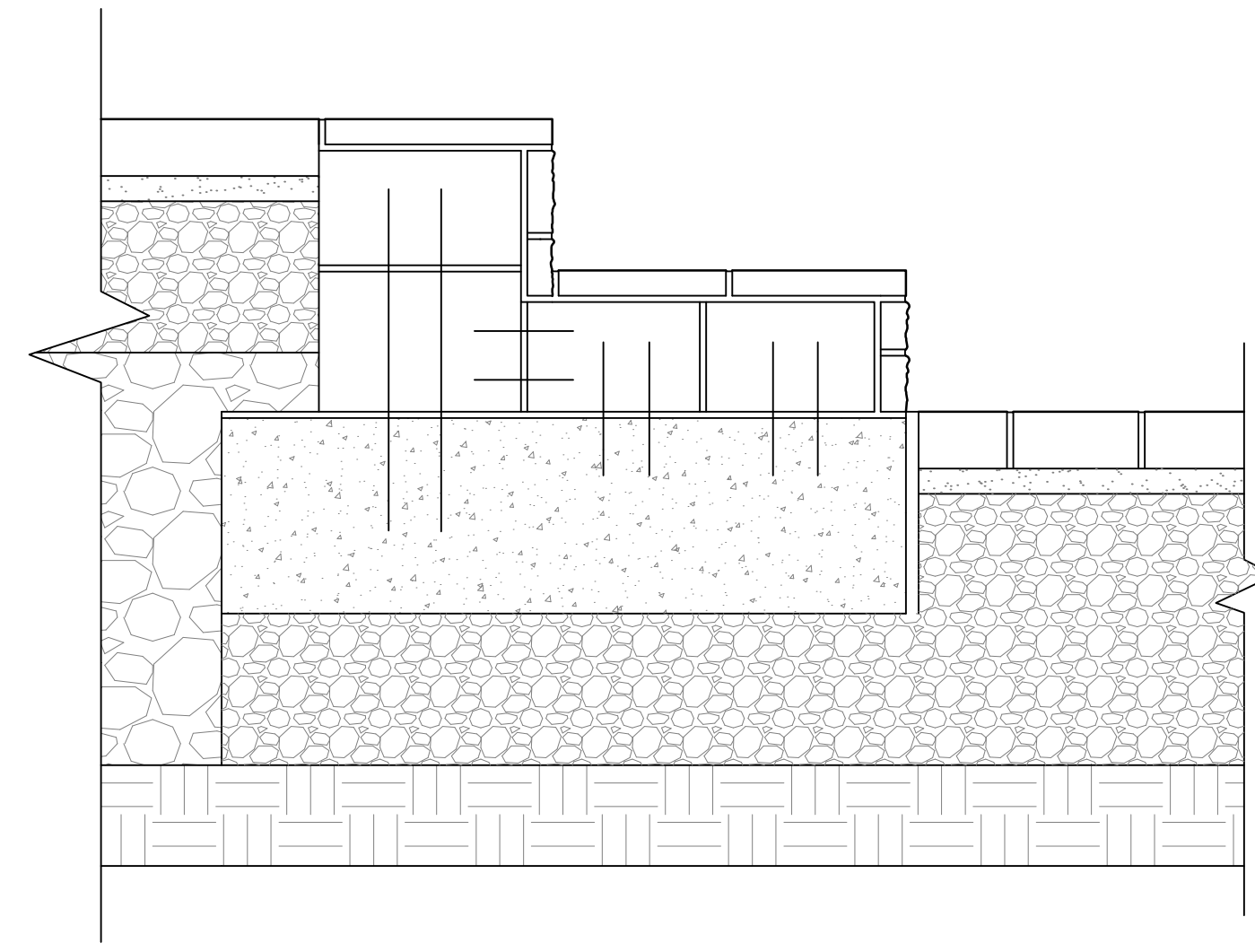

BRICK STEP DETAIL
 SCALE: NTS

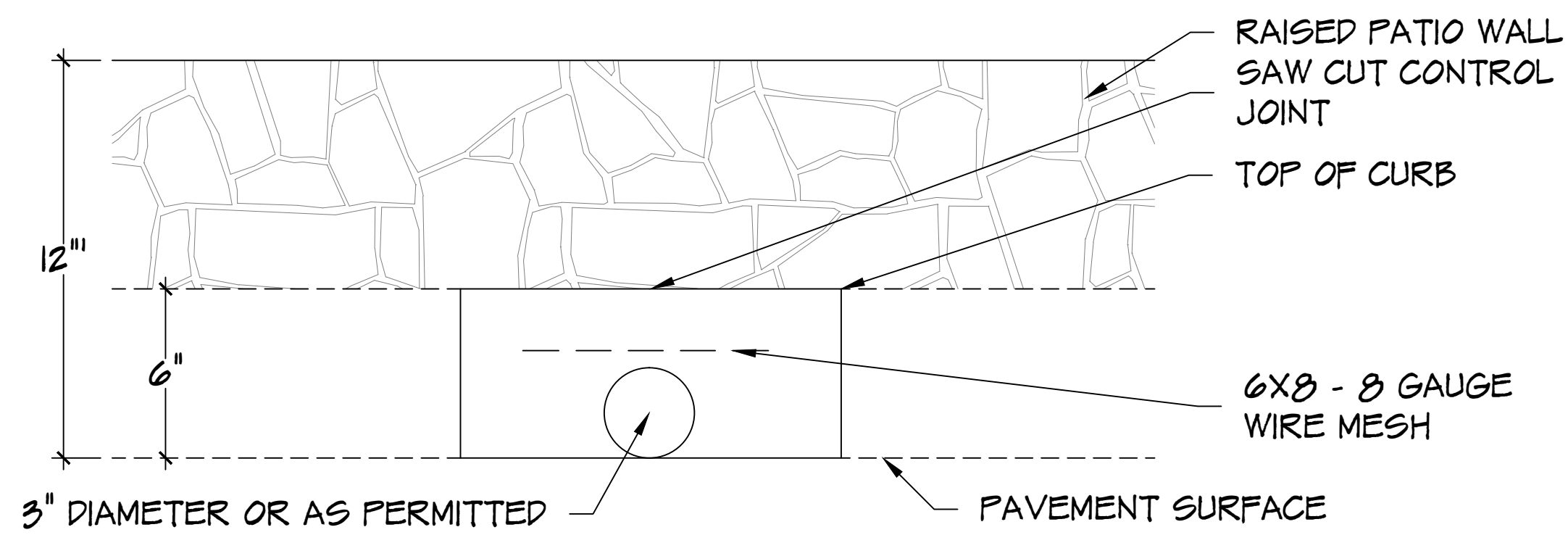
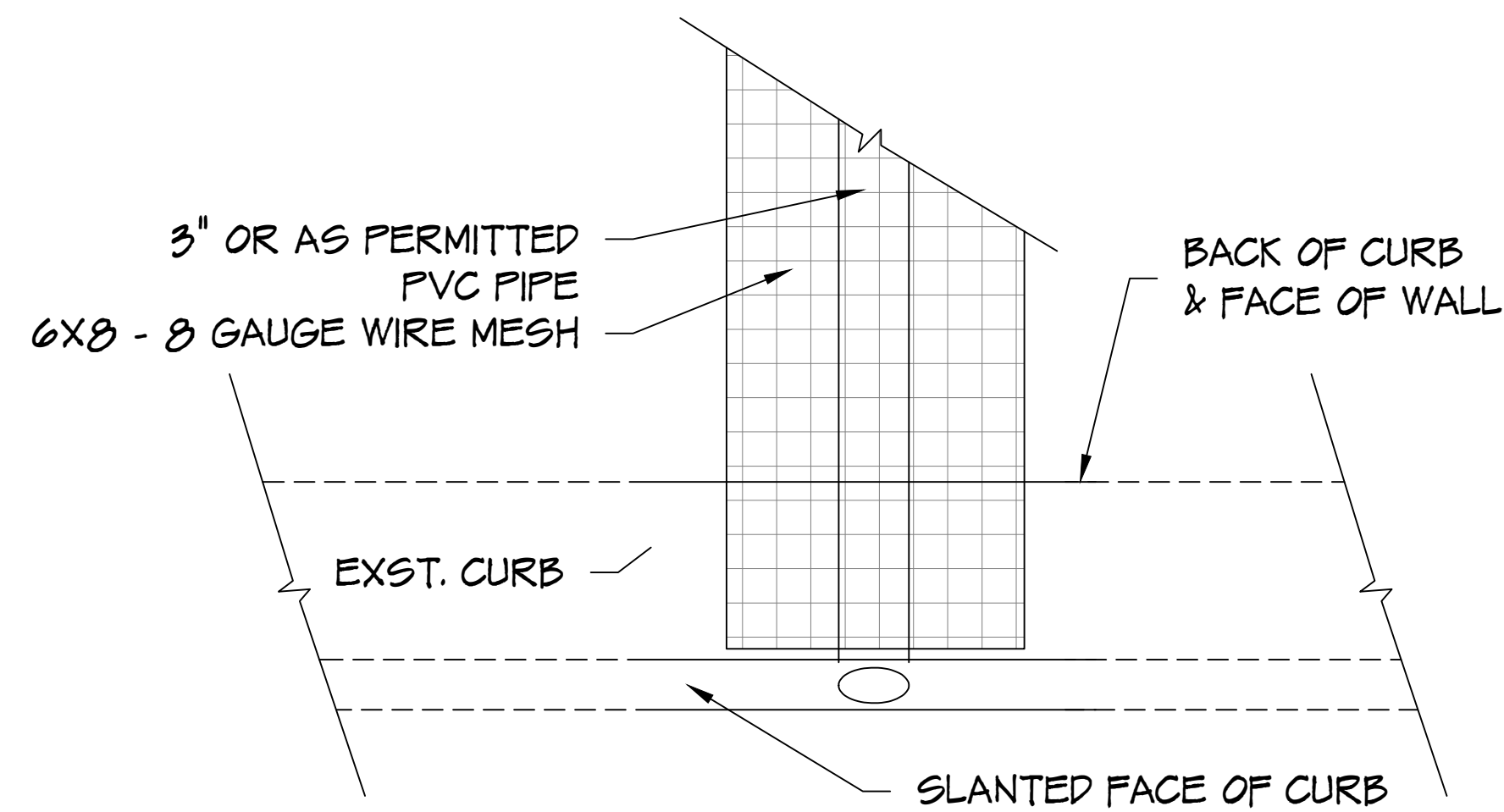

CURB CUT DETAIL
 SCALE: NTS

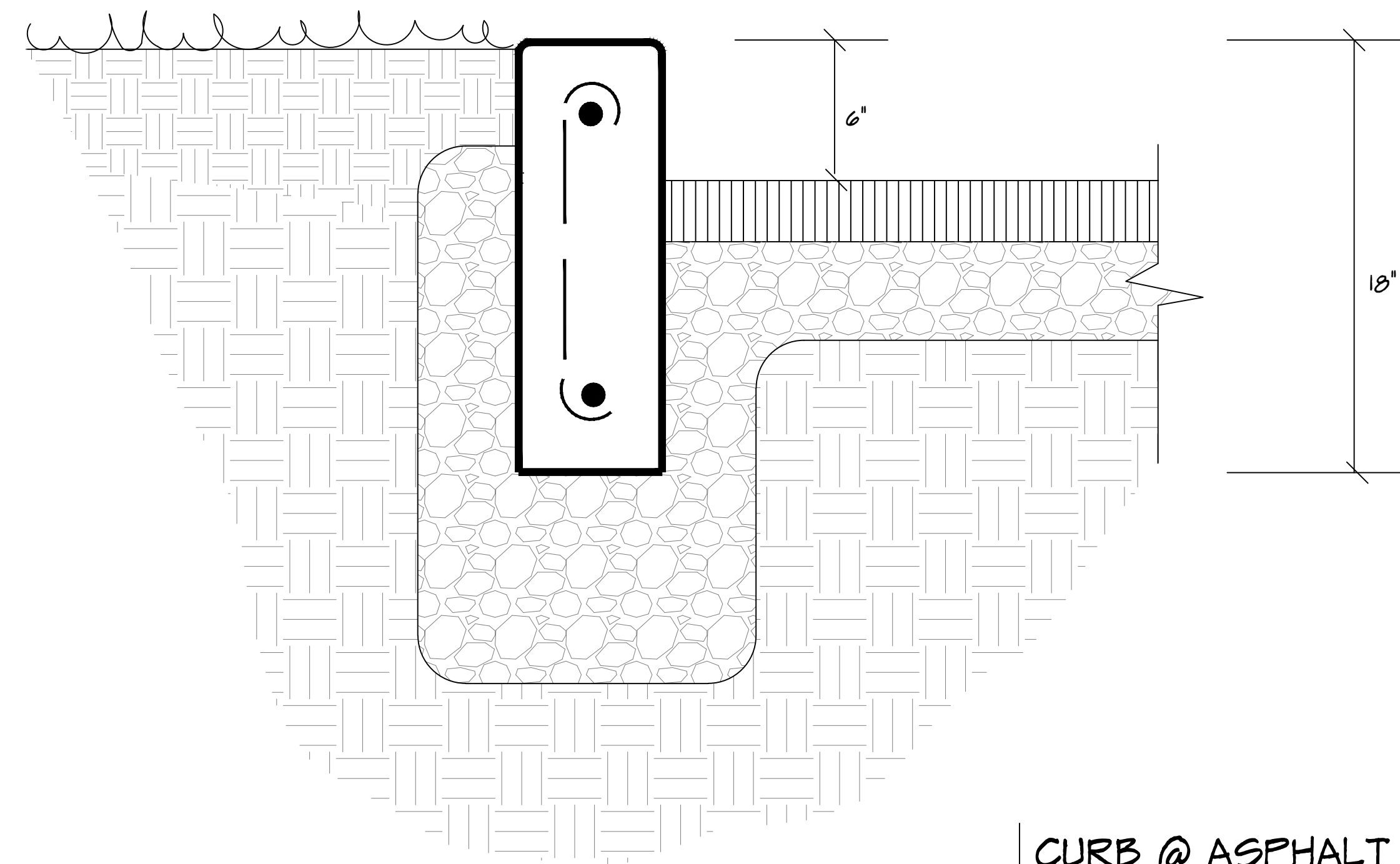

CURB @ ASPHALT DETAIL
 SCALE: NTS

Designed By: MICHAEL COYLE
 Drawn By: MICHAEL COYLE
 Approved By:
 Date: NOVEMBER 9, 2018

Sheet Title:
**HARDSCAPE
 DETAILS**

Scale: NTS

Sheet No.
L - 6

Revisions:	DATE
4.9.19	

M.J. Design
 ASSOCIATES INC.
 LANDSCAPE DESIGN • BUILD • MAINTENANCE
 www.mjdesignassociates.com
 ADDRESS: 8463 ESTATES CT. #104
 PLAIN CITY, OH 43064

GALBREATH REAL ESTATE
 75 S. High Street
 Dublin, OH 43017

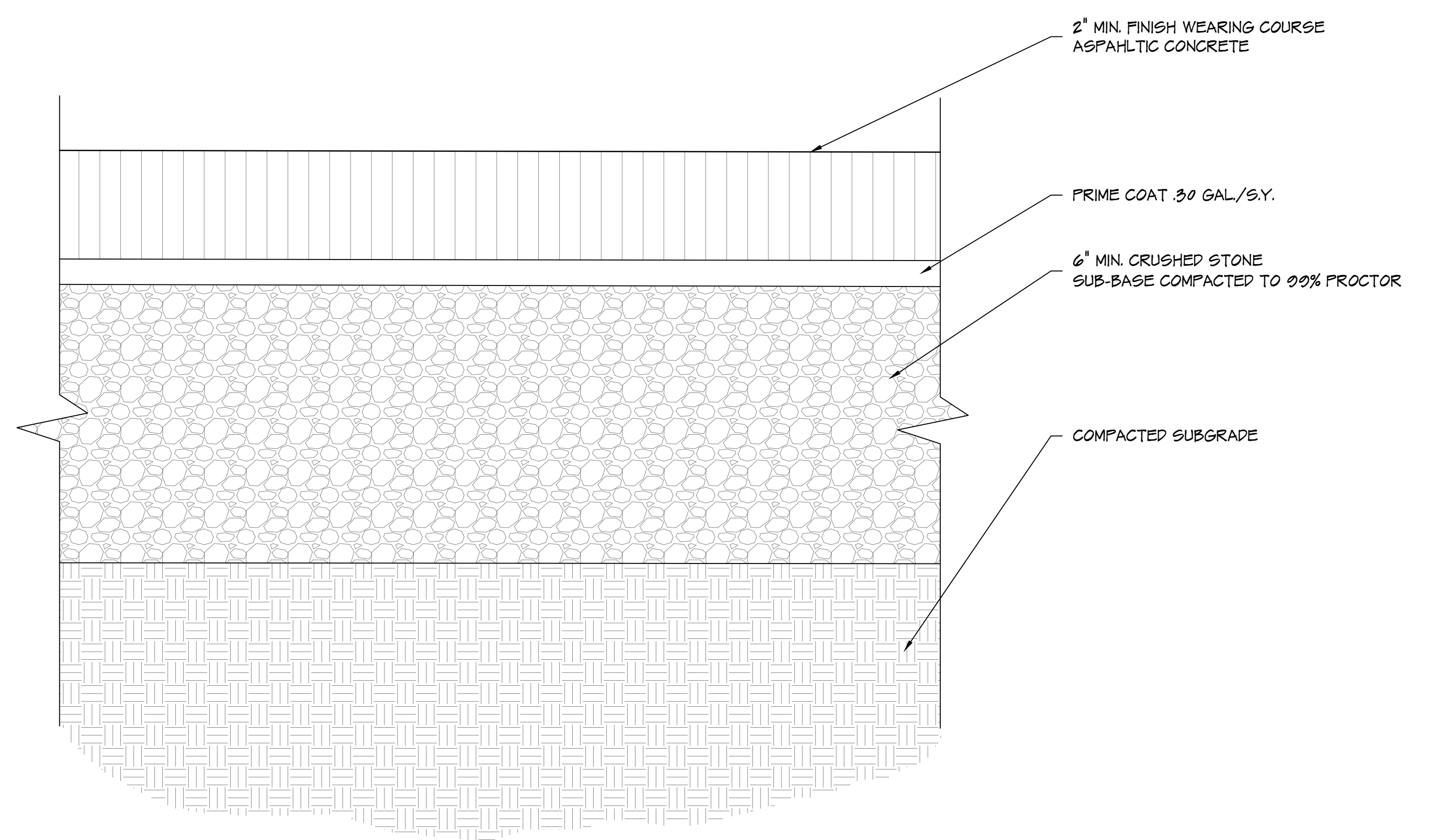

ASPHALT PARKING LOT DETAIL
 SCALE: NTS

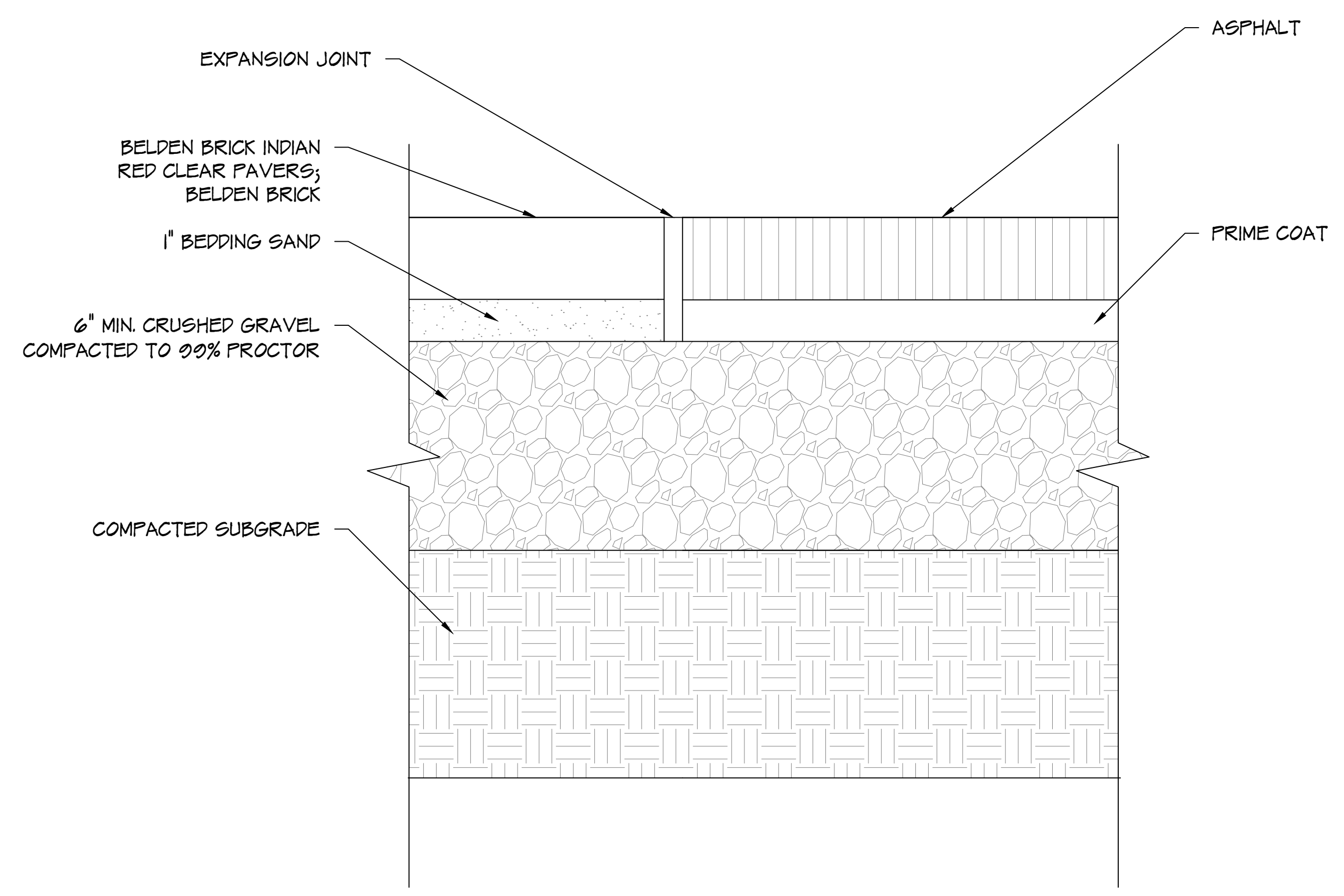

ASPHALT @ BRICK WALKWAY DETAIL
 SCALE: NTS

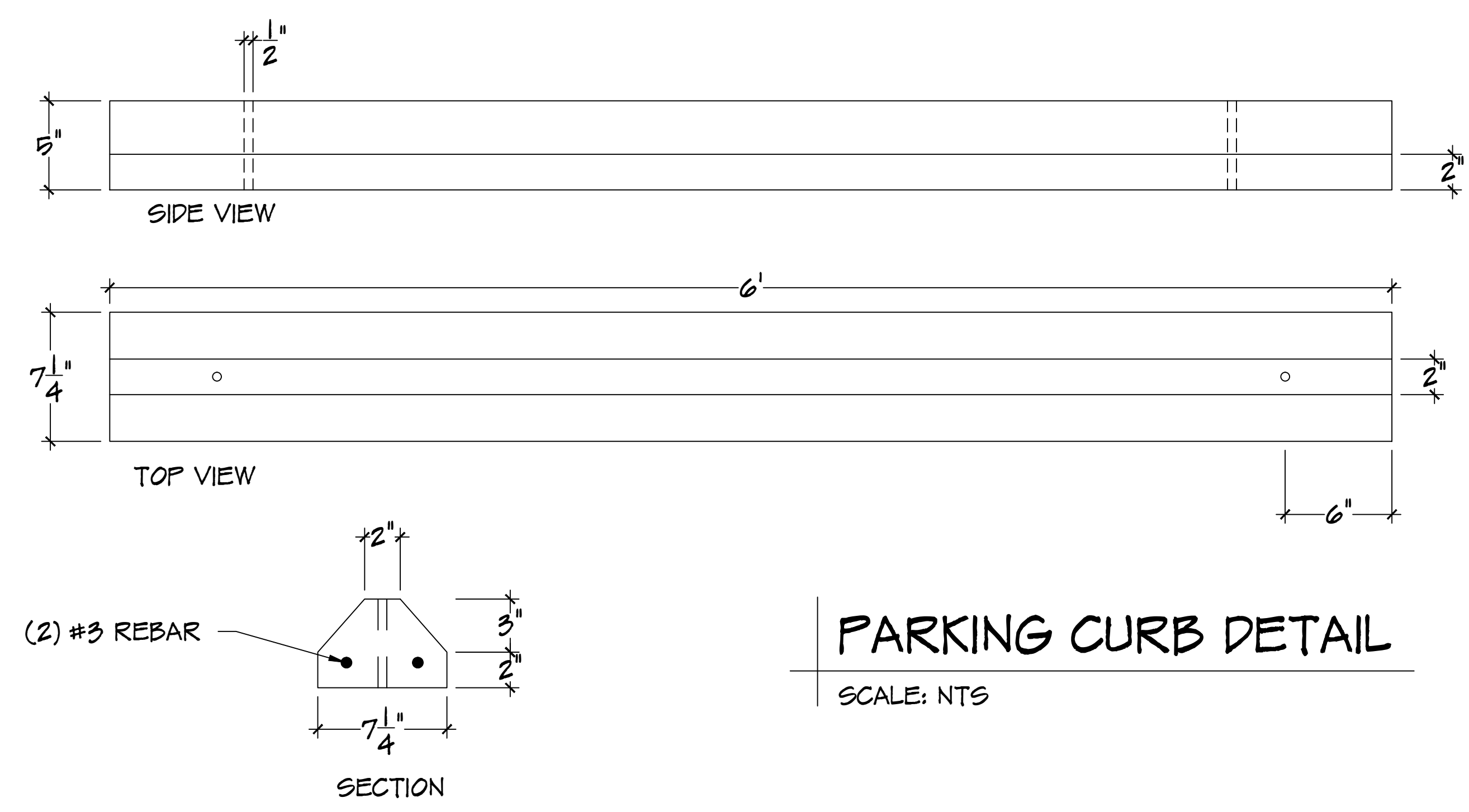

PARKING CURB DETAIL
 SCALE: NTS

Designed By: MICHAEL COYLE
 Drawn By: MICHAEL COYLE
 Approved By:
 Date: NOVEMBER 9, 2018

Sheet Title:
HARDSCAPE DETAILS

Scale: NTS

Sheet No.
L - 6.1

Revisions:	DATE
4.9.19	
4.23.19	

M.J. Design
 ASSOCIATES INC.
 LANDSCAPE DESIGN • BUILD • MAINTENANCE
 www.mjdesignassociates.com
 ADDRESS: 8463 ESTATES CT. #14873.7333
 PLAIN CITY, OH 43064 614.873.7444

GALBREATH REAL ESTATE
 75 S. High Street
 Dublin, OH 43017

Designed By: MICHAEL COYLE
 Drawn By: MICHAEL COYLE
 Approved By:
 Date: NOVEMBER 9, 2018

Sheet Title:
**HARDSCAPE
 DETAILS**

Scale: NTS

Sheet No.
L - 6.2

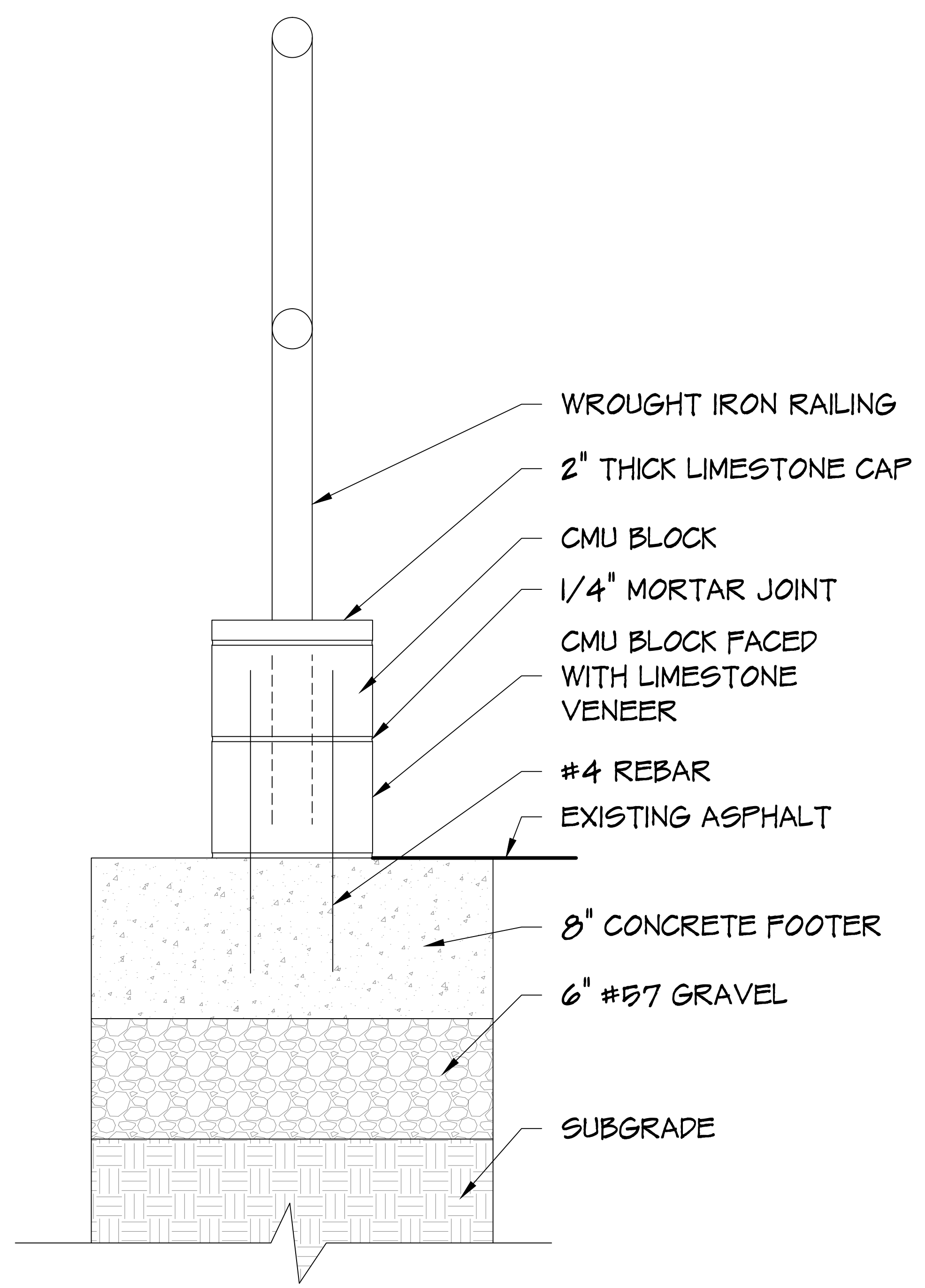

RAILING SECTION

SCALE: NTS

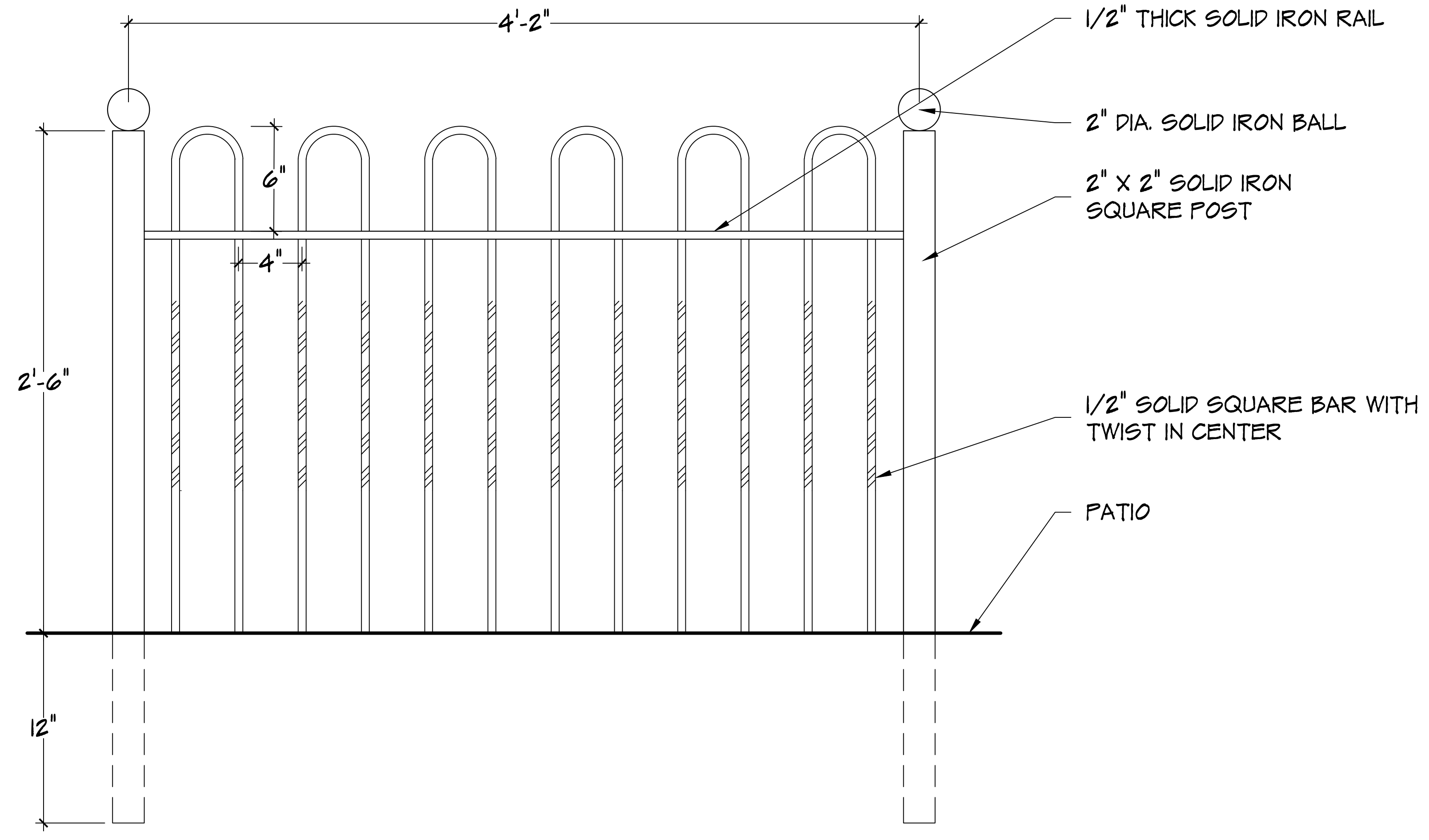

RAILING PANEL ELEVATION

SCALE: NTS



NORTH PATIO



WEST PATIO

Revisions:

DATE	
4.9.19	

M.J. Design
 ASSOCIATES INC.
 LANDSCAPE DESIGN • BUILD • MAINTENANCE
 www.mjdesignassociates.com
 ADDRESS: 8463 ESTATES CT. 614.873.7333
 PLAIN CITY, OH 43064 614.873.7444

GALBREATH REAL ESTATE

75 S. High Street
 Dublin, OH 43017

Designed By: MICHAEL COYLE
 Drawn By: MICHAEL COYLE
 Approved By: _____
 Date: NOVEMBER 9, 2018

Sheet Title:
3D CONCEPTS

Scale: NTS

Sheet No.
L - 7

WROUGHT IRON RAILING EXAMPLE



LIMESTONE VENEER TO MATCH EXISTING BUILDING
MORTAR JOINTS TO MATCH



BELDEN BRICK INDIAN RED CLEAR PAVERS



Revisions:

DATE	

M.J. Design
ASSOCIATES INC.
LANDSCAPE DESIGN • BUILD • MAINTENANCE
www.mjdesignassociates.com
ADDRESS: 8463 ESTATES CT. #100
PLAIN CITY, OH 43064
PHONE: 614.873.7333
FAX: 614.873.7444

GALBREATH REAL ESTATE

75 S. High Street
Dublin, OH 43017

Designed By: MICHAEL COYLE

Drawn By: MICHAEL COYLE

Approved By: _____

Date: NOVEMBER 9, 2018

Sheet Title:

MATERIALS

Scale: NTS

Sheet No.
L - 8