

Site Reference Plan
SCALE: 1" = 40'-0"

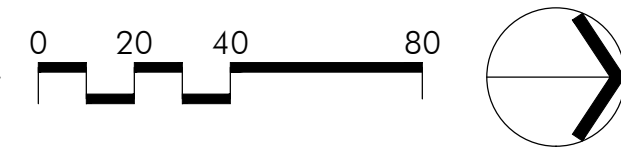

-BEAN-
ARCHITECTS

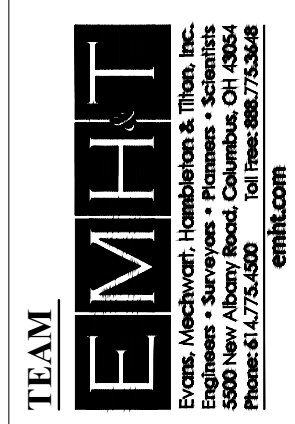

PREPARED FOR
DAIMLER
Development • Leasing • Construction • Sales
Damier Group
1533 Lake Shore Dr # 100,
Columbus, OH 43204

PROJECT NAME
The Corners - Park and Public Infrastructure
Frantz Road
Dublin, Ohio

PROJECT INFO
Project #: 20190873
By: SK/JW/AC
Date: 06/26/2020

SHEET TITLE
Site Reference Plan

SHEET NUMBER
L-9

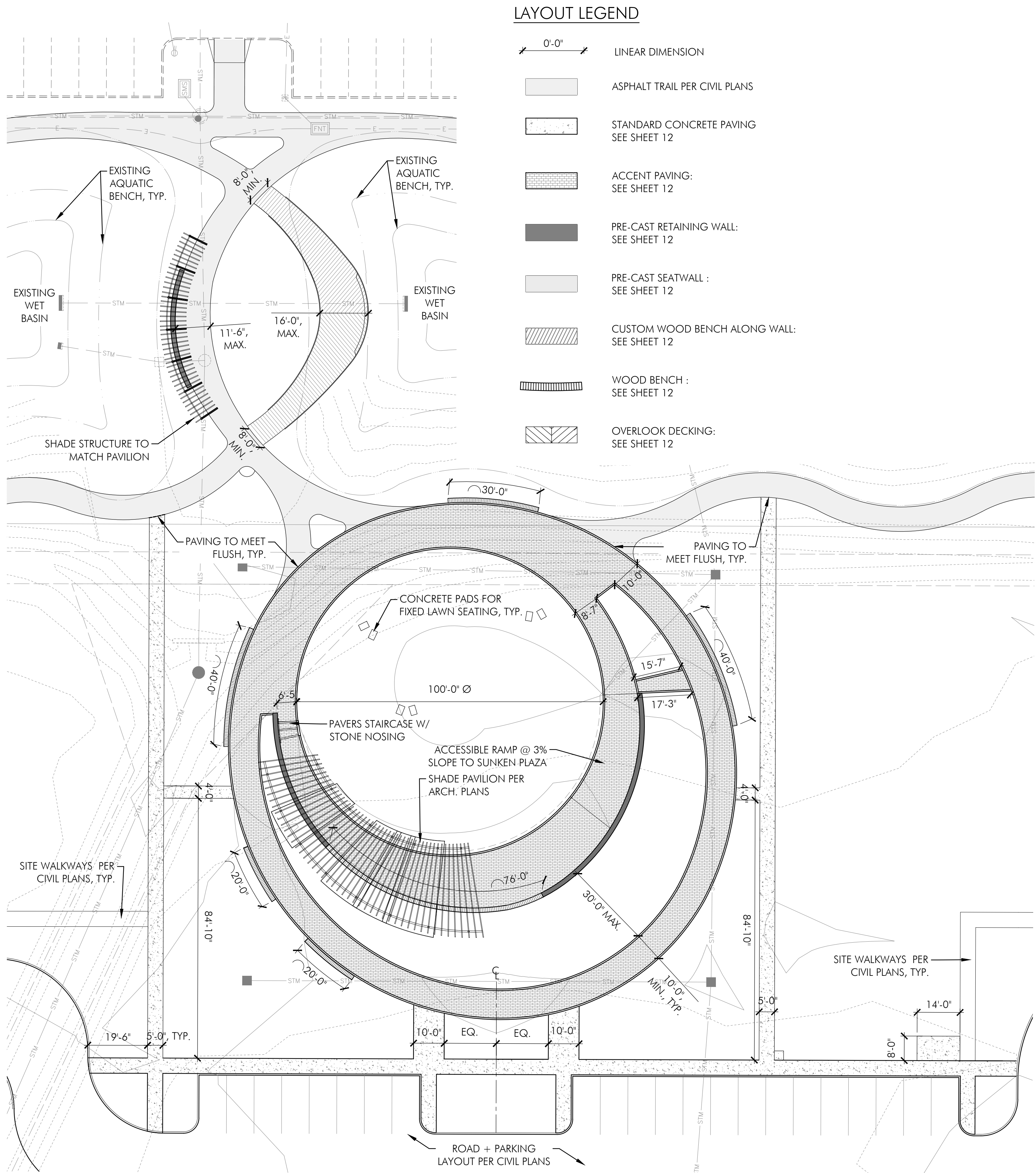

LAYOUT LEGEND

- 0'-0" LINEAR DIMENSION
- ASPHALT TRAIL PER CIVIL PLANS
- STANDARD CONCRETE PAVING SEE SHEET 12
- ACCENT PAVING: SEE SHEET 12
- PRE-CAST RETAINING WALL: SEE SHEET 12
- PRE-CAST SEATWALL : SEE SHEET 12
- CUSTOM WOOD BENCH ALONG WALL: SEE SHEET 12
- WOOD BENCH : SEE SHEET 12
- OVERLOOK DECKING: SEE SHEET 12

Overlook + Loop Layout Plan
SCALE: 1" = 20'-0"

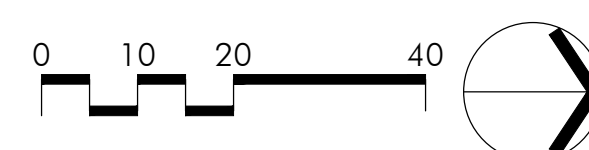

CONCEPTUAL IMAGES
IMAGES SHOWN FOR DESIGN INTENT ONLY : NOT TO SCALE

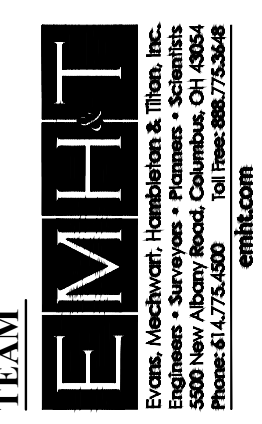
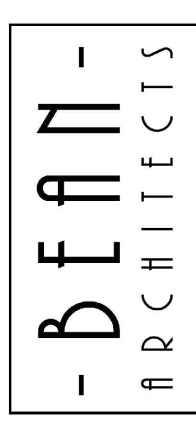

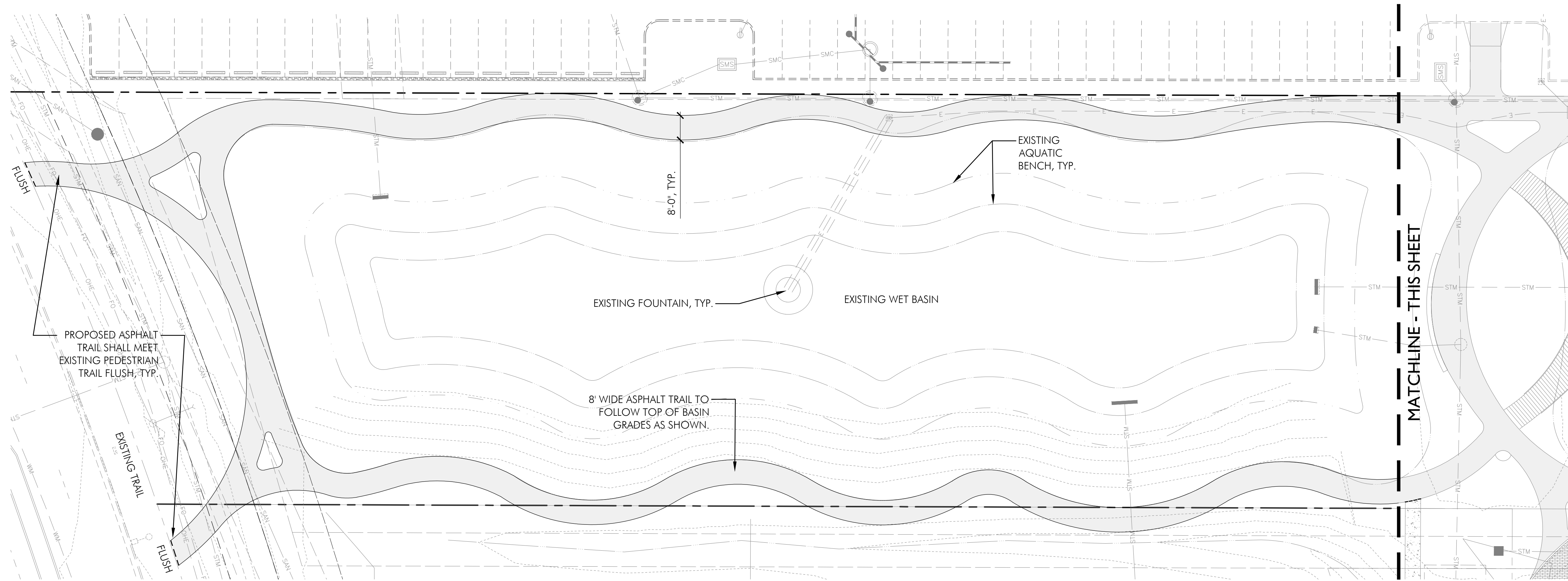

LAYOUT LEGEND

0'-0" LINEAR DIMENSION

ASPHALT TRAIL PER CIVIL PLANS

Pond Loop South Layout Plan
SCALE: 1" = 20'-0"

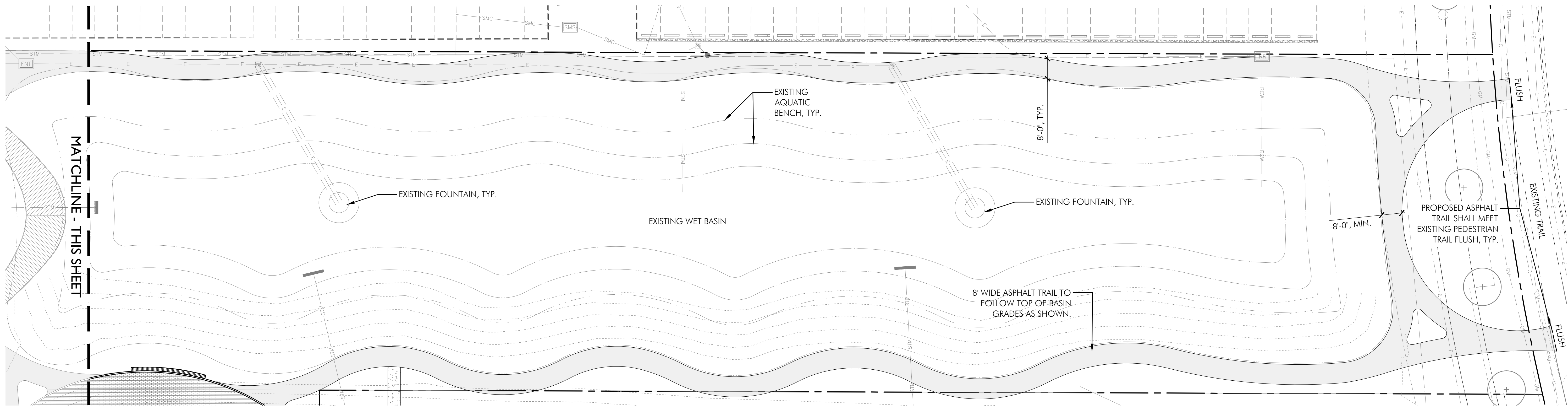

Pond Loop North Layout Plan
SCALE: 1" = 20'-0"

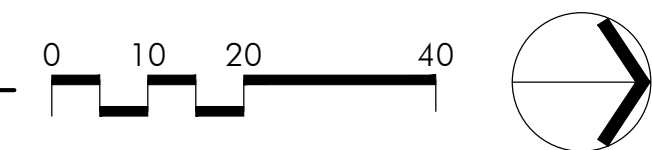

- DEAN -
ARCHITECTS

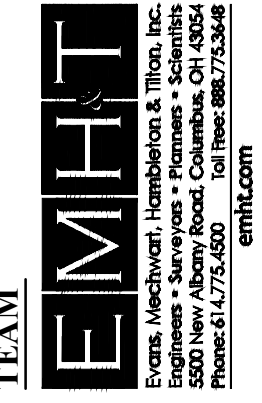

PREPARED FOR
Daimler Group
1533 Lake Shore Dr. # 100,
Columbus, OH 43204

DAIMLER
Development • Leasing • Construction • Sales

PROJECT NAME
The Corners - Park and Public
Infrastructure
Frantz Road
Dublin, Ohio

PROJECT INFO
Project #: 20190873
By: SK/JW/AC
Date: 06/26/2020

SHEET TITLE
Pond Loops Layout
Plans

SHEET NUMBER
L-11

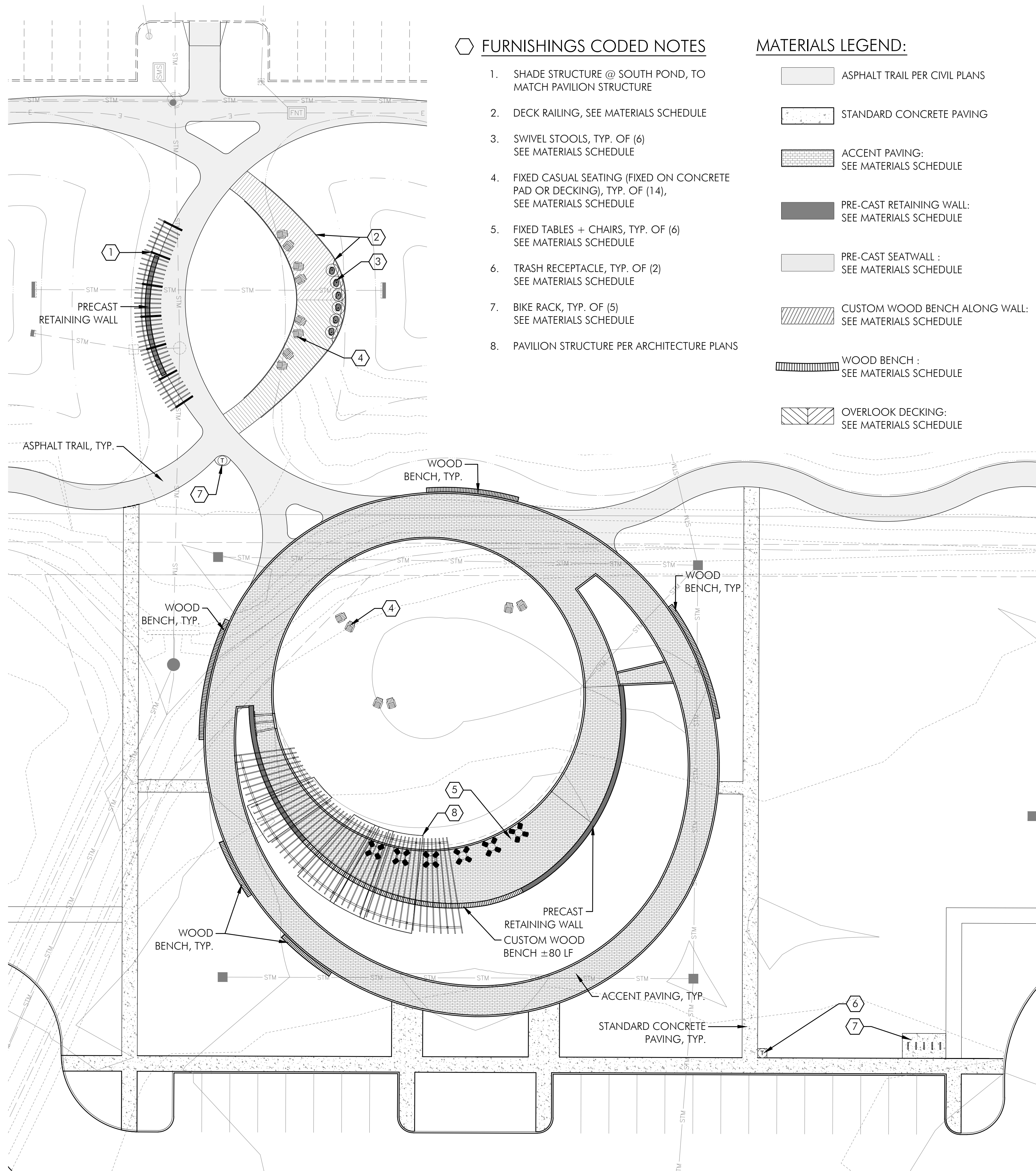

FURNISHINGS CODED NOTES

1. SHADE STRUCTURE @ SOUTH POND, TO MATCH PAVILION STRUCTURE
2. DECK RAILING, SEE MATERIALS SCHEDULE
3. SWIVEL STOOLS, TYP. OF (6)
SEE MATERIALS SCHEDULE
4. FIXED CASUAL SEATING (FIXED ON CONCRETE PAD OR DECKING), TYP. OF (14),
SEE MATERIALS SCHEDULE
5. FIXED TABLES + CHAIRS, TYP. OF (6)
SEE MATERIALS SCHEDULE
6. TRASH RECEPTACLE, TYP. OF (2)
SEE MATERIALS SCHEDULE
7. BIKE RACK, TYP. OF (5)
SEE MATERIALS SCHEDULE
8. PAVILION STRUCTURE PER ARCHITECTURE PLANS

MATERIALS LEGEND:

- ASPHALT TRAIL PER CIVIL PLANS
- STANDARD CONCRETE PAVING
- ACCENT PAVING:
SEE MATERIALS SCHEDULE
- PRE-CAST RETAINING WALL:
SEE MATERIALS SCHEDULE
- PRE-CAST SEATWALL :
SEE MATERIALS SCHEDULE
- CUSTOM WOOD BENCH ALONG WALL:
SEE MATERIALS SCHEDULE
- WOOD BENCH :
SEE MATERIALS SCHEDULE
- OVERLOOK DECKING:
SEE MATERIALS SCHEDULE

MATERIALS SCHEDULE

FURNISHINGS

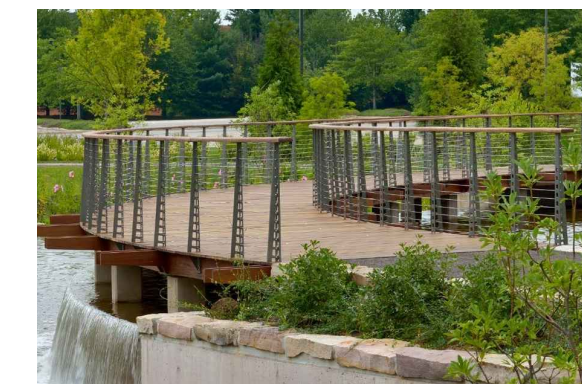

DECK RAILING
DESCRIPTION : METAL RAILING W/CABLE WIRING + EXTENDED HANDRAIL / LEAN RAIL
NOTE: IMAGE SHOWN FOR DESIGN INTENT ONLY

QUANTITY : ± 170 LF
FORTIN IRONWORKS
614-291-4342
WWW.FORTINIRONWORKS.COM



SWIVEL STOOLS
DESCRIPTION : BERNIE STOOL
COLOR / FINISH : POWDERCOATED STORMCLOUD
MOUNT : SURFACE

QUANTITY : 6
LANDSCAPE FORMS
PHONE NUMBER
WWW.LANDSCAPEFORMS.COM



CASUAL SEATING
DESCRIPTION : LOLLYGAGGER LOUNGE CHAIR
COLOR / FINISH : DRIFTWOOD
NOTE : REQUEST ANCHORS FOR FIXING CHAIRS TO CONCRETE + DECKING

QUANTITY : 14
LOLL DESIGNS
P. 877-740-3387
WWW.LOLLDESIGN.COM



FIXED TABLE + CHAIRS
DESCRIPTION : VOLARE COURTYARD TABLE
4 SEATS (BACKED), EMBEDDED MOUNT
TABLE MATERIAL : ROUND | POWDERCOAT
COLOR / FINISH : WHITE

QUANTITY : 6
THOMAS STEELE
P. 1-800-448-7931
WWW.THOMAS-STEELE.COM



TRASH RECEPTACLES
DESCRIPTION : STEELITES COLLECTION
COLOR / FINISH : BLACK
MOUNT : EMBEDDED
MODEL # : A-45 GALLON

QUANTITY : 2
VICTOR STANLEY
P. 301-855-8300
WWW.VICTORSTANLEY.COM



BIKE RACK
DESCRIPTION : RIDE BIKE RACK
COLOR / FINISH : POWDERCOATED STORMCLOUD
MOUNT : EMBEDDED

QUANTITY : 5
LANDSCAPE FORMS
P. 269-276-4440
WWW.LANDSCAPEFORMS.COM

NOTE:
ALL FURNISHINGS + FINISHES
PENDING APPROVAL PER FINAL
DEVELOPMENT PLANS

HARDSCAPE

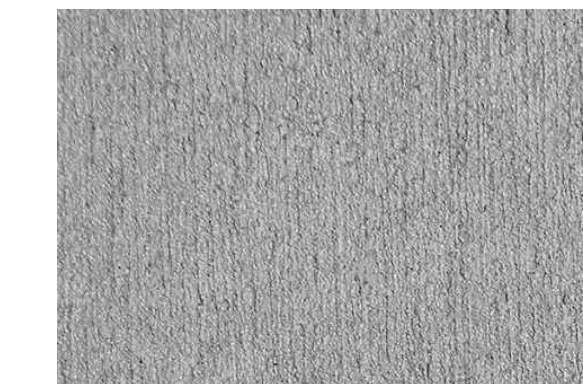

STANDARD CONCRETE PAVING
COLOR / FINISH : NATURAL GREY
LIGHT BROOM FINISH



ACCENT PAVING
DESCRIPTION : ECO PREMIER PAVERS
COLOR / FINISH : GREY BLEND HEP-10, HEP-20
SIZE : 6" x 24"
QUANTITY : 9,990 SF

TECTURA DESIGNS
CONTACT : BRYAN HENNE
P. 412-445-4898
WWW.TECTURADESIGNS.COM



PRE-CAST CONCRETE (SEAT + RETAINING WALLS)
DESCRIPTION : PRE-CAST CONCRETE UNITS
COLOR / FINISH : W31

WAUSAU TILE
CONTACT : BRYAN HENNE
P. 412-445-4898
WWW.WAUSAUTILE.COM



CUSTOM WOOD BENCH
DESCRIPTION : CUSTOM SEATWALL BENCH
COLOR / FINISH : THERMALLY MODIFIED ASH
QUANTITY : ± 80 LF

LANDSCAPE FORMS
P. 269-276-4440
WWW.LANDSCAPEFORMS.COM

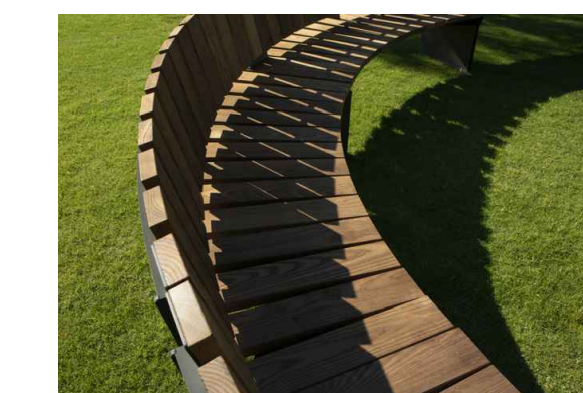

WOOD BENCHES
DESCRIPTION : LINK BENCH
COLOR / FINISH : THERMALLY MODIFIED ASH
QUANTITY : ± 12

LANDSCAPE FORMS
P. 269-276-4440
WWW.LANDSCAPEFORMS.COM



OVERLOOK DECKING
DESCRIPTION : THERMALLY MODIFIED ASH
COLOR / FINISH : BENCHMARK WHITE ASH
SIZE : 1 x 4
QUANTITY : ± 1,175 SF

THERMORY USA
P. 800-XXX-XXXX
WWW.THERMORYUSA.COM

PLANTING LEGEND

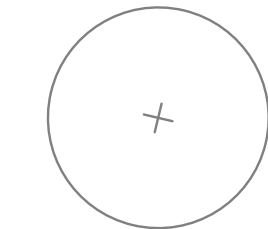

EXISTING TREE TO REMAIN

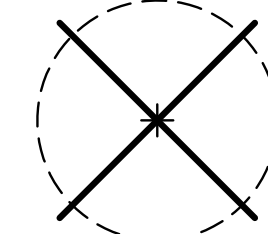

DECIDUOUS TREES TO BE REMOVED

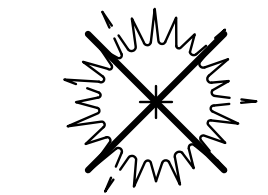

EVERGREEN TREES TO BE REMOVED

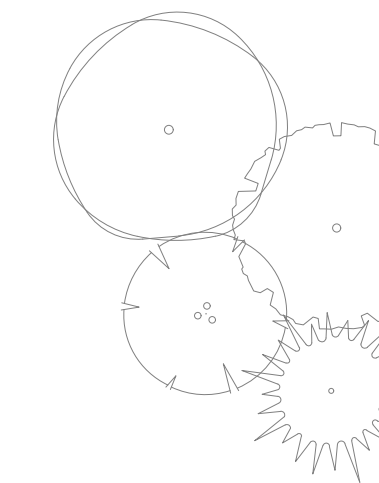

PROPOSED TREES - SEE SHEET 14, 16-17

TREE REPLACEMENT REQUIREMENTS:

TOTAL CALIPER INCHES TO BE REMOVED : 224 (65 TREES)

TOTAL CALIPER INCHES TO BE REPLACED : 224

TOTAL CALIPER INCHES PROPOSED :

303 (101 LARGE DECIDUOUS TREES 3" CALIPER)

92 (46 MEDIUM TREES @ 2" CAL)

112 (56 MULTI-STEM TREES @ 10' HT. / 2" CAL)

52 (26 EVERGREEN TREES @ 10' HT. / 2" CAL)

TOTAL : 583 CALIPER INCHES

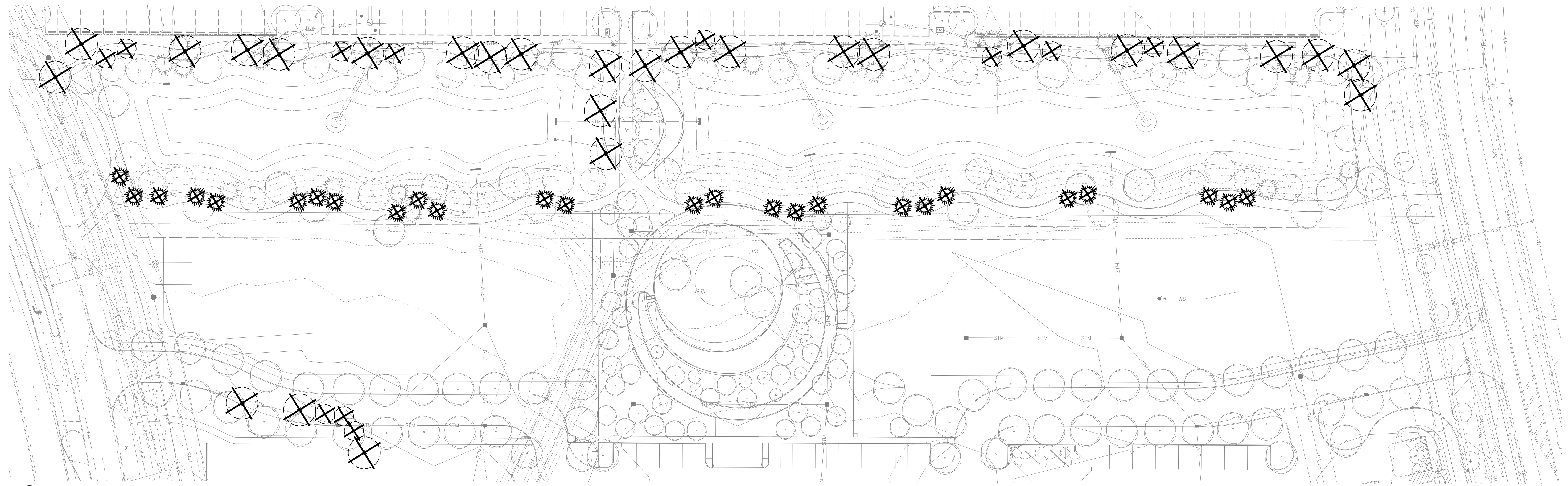

Tree Replacement Plan
SCALE: 1" = 20'-0"

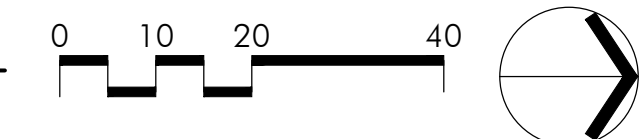

POD Design
100 Northwoods Blvd, Ste A
Columbus, Ohio 43235
p 614.255.3399
pod@design.net



-BEAN-
ARCHITECTS

TEAM
EMHT
EMHT
Survey, Mechanical, Hazardous & Traffic, Inc.
Engineers • Surveyors • Planners • Scientists
11000 Northpark Drive, Columbus, OH 43240
Phone: 614.776.6600
emht.com

PREPARED FOR
Daimler Group
1533 Lake Shore Dr. # 100,
Columbus, OH 43204

DAIMLER
Development • Leasing • Construction • Sales

PROJECT NAME
The Corners - Park and Public Infrastructure
Frantz Road
Dublin, Ohio

PROJECT INFO
Project #: 20190873
By: SK/JW/AC
Date: 06/26/2020

SHEET TITLE
Tree Replacement Plan

SHEET NUMBER
L-13

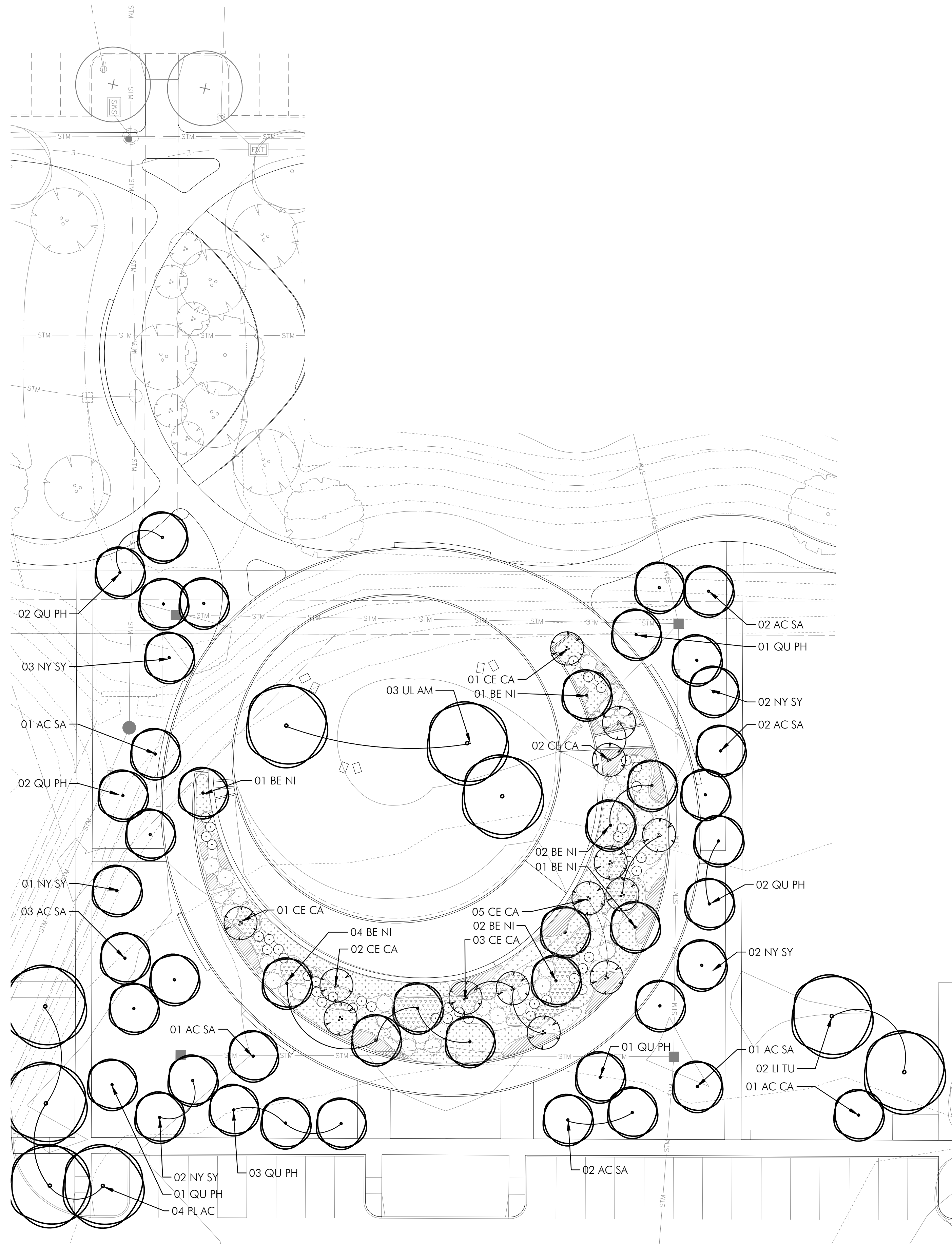

PLANTING LEGEND

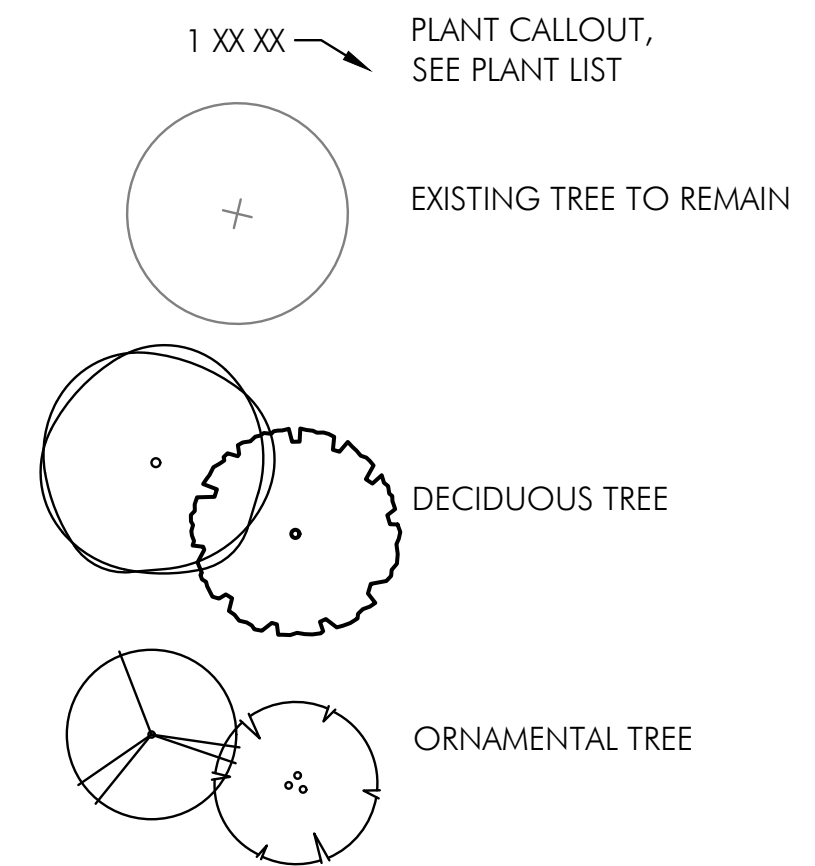

PLANT LIST

QTY.	SYMBOL	BOTANICAL & COMMON NAMES	SIZE	COND.	REMARKS
REPLACEMENT TREES					
	LI TU	Liriodendron tulipifera 'Emerald City' Emerald City Tulip Tree	3" Cal.	B&B	
	PL AC	Platanus x acerifolia 'Morton Circle' Exclamation! London Planetree	3" Cal.	B&B	
	UL AM	Ulmus americana 'Princeton' Princeton Elm	3" Cal.	B&B	
DECIDUOUS TREES					
	AC SA	Acer saccharum 'Green Mountain' Green Mountain Sugar Maple	2" Cal.	B&B	
	BE NI	Betula nigra 'Dura-Heat' Dura Heat River Birch	15' Ht.	B&B	(3) Multi-stem 2" cal./stem
	NY SY	Nyssa sylvatica 'Fire Master' Fire Master Black Gum	2" Cal.	B&B	
	QU PH	Quercus phellos Willow Oak	2" Cal.	B&B	
ORNAMENTAL TREES					
	CE CA	Cercis canadensis var. texensis 'Oklahoma' Oklahoma Redbud	10' ht.	B&B	(3) Multi-stem 2" cal./stem

Overlook + Loop Canopy Planting Plan
SCALE: 1" = 20'-0"

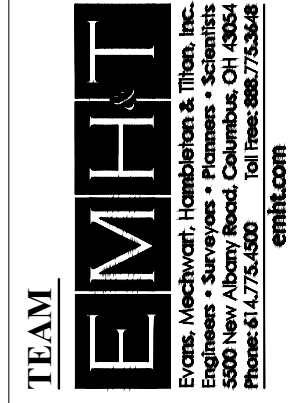
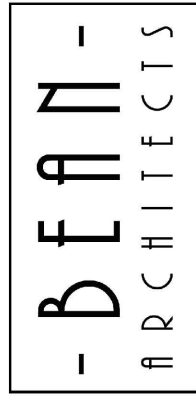

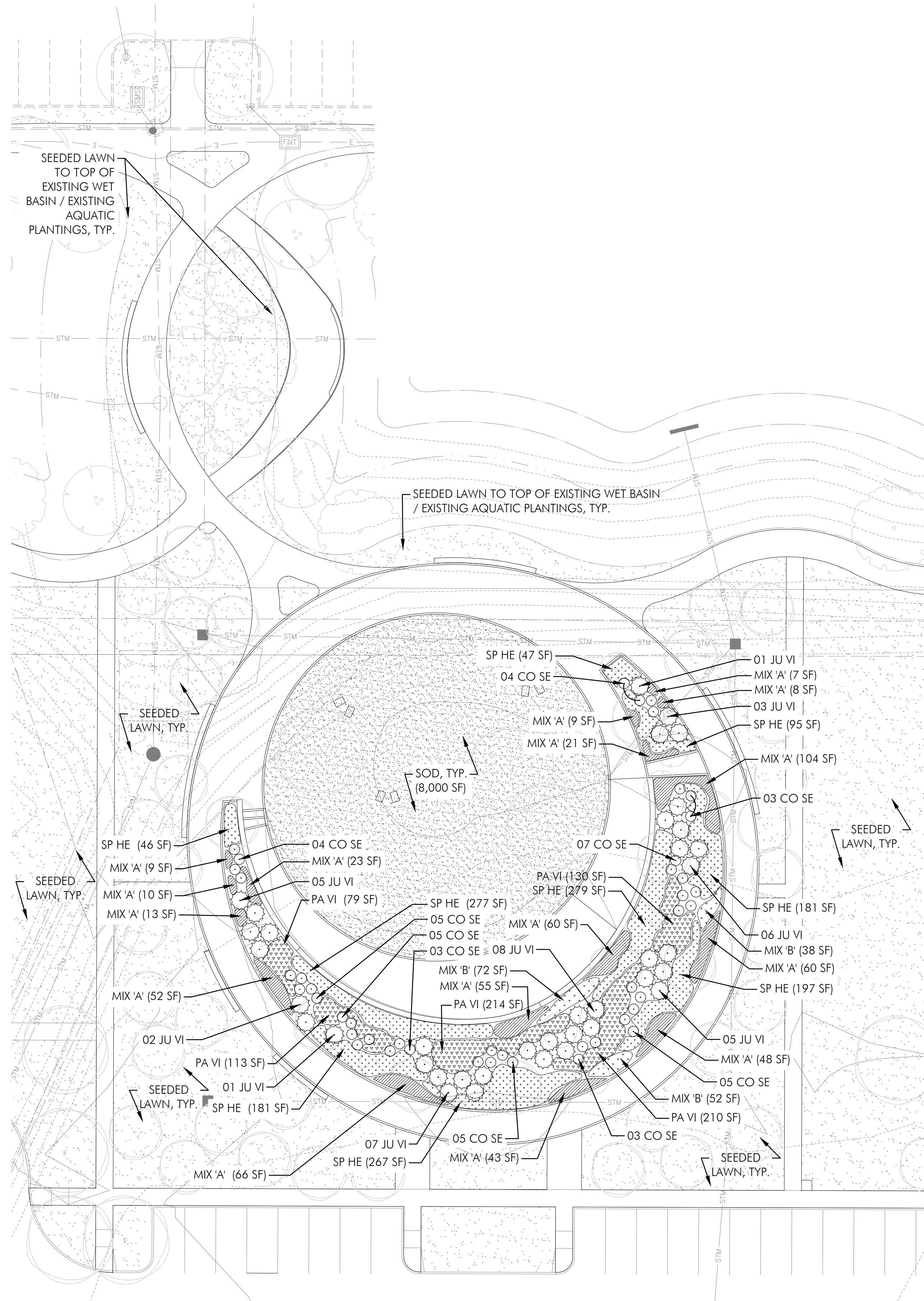

PLANTING LEGEND

- 1 XX XX — PLANT CALLOUT, SEE PLANT LIST
- SHRUBS
- SEEDED LAWN OR SOD (AS NOTED)
- ORNAMENTAL GRASSES: SP HE
- ORNAMENTAL GRASSES: PA VI
- MIX 'A': GA NI NE FA
- MIX 'B': EC BS EC CL

PLANT LIST

QTY.	SYMBOL	BOTANICAL & COMMON NAMES	SIZE	COND.	REMARKS
SHRUBS					
	CO SE	Cornus sericea 'Farrow' Arctic Fire® Red Twig Dogwood	24" ht.	#3 cont.	AS SHOWN
	JU VI	Juniperus virginiana 'Grey Owl' Grey Owl Juniper	24" ht.	#5 cont.	AS SHOWN
PERENNIALS/ ORNAMENTAL GRASSES/ GROUNDCOVERS					
	EC BS	Echinacea 'Big Sky Harvest Moon' Big Sky Harvest Moon Coneflower	Clump	#1 cont.	24" o.c.
	EC CL	Echinacea 'Coconut Lime' Coconut Lime Coneflower	Clump	#1 cont.	24" o.c.
	GA NI	Galanthus nivalis Snowdrops	Clump	#1 cont.	4" o.c.
	NE FA	Nepeta x faassenii 'Walker's Low' Walker's Low Catmint	Clump	#1 cont.	12" o.c.
	PA VI	Panicum virgatum 'Cheyenne Sky' Cheyenne Sky Switch Grass	Clump	#1 cont.	18" o.c.
	SP HE	Sporobolus heterolepis Prairie Dropseed	Clump	#1 cont.	30" o.c.

SEASONAL COLOR CHART

	EARLY SPRING	MID SPRING	LATE SPRING	EARLY SUMMER	MID SUMMER	LATE SUMMER	FALL	WINTER
SHRUBS								
CO SE - ARCTIC FIRE DOGWOOD								
JU VI - GREY OWL JUNIPER								
PERENNIALS								
EC BS - BIG SKY HARVEST MOON CONEFLOWER								
EC CL - COCONUT LIME CONEFLOWER								
GA NI - SNOWDROPS								
NE FA - WALKERS LOW CATMINT								
PA VI - CHEYENNE SWITCHGRASS								
SP HE - PRAIRIE DROPSEED								

PLANTING IMAGES

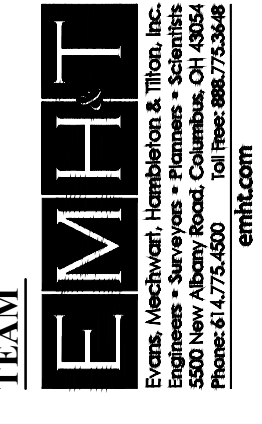

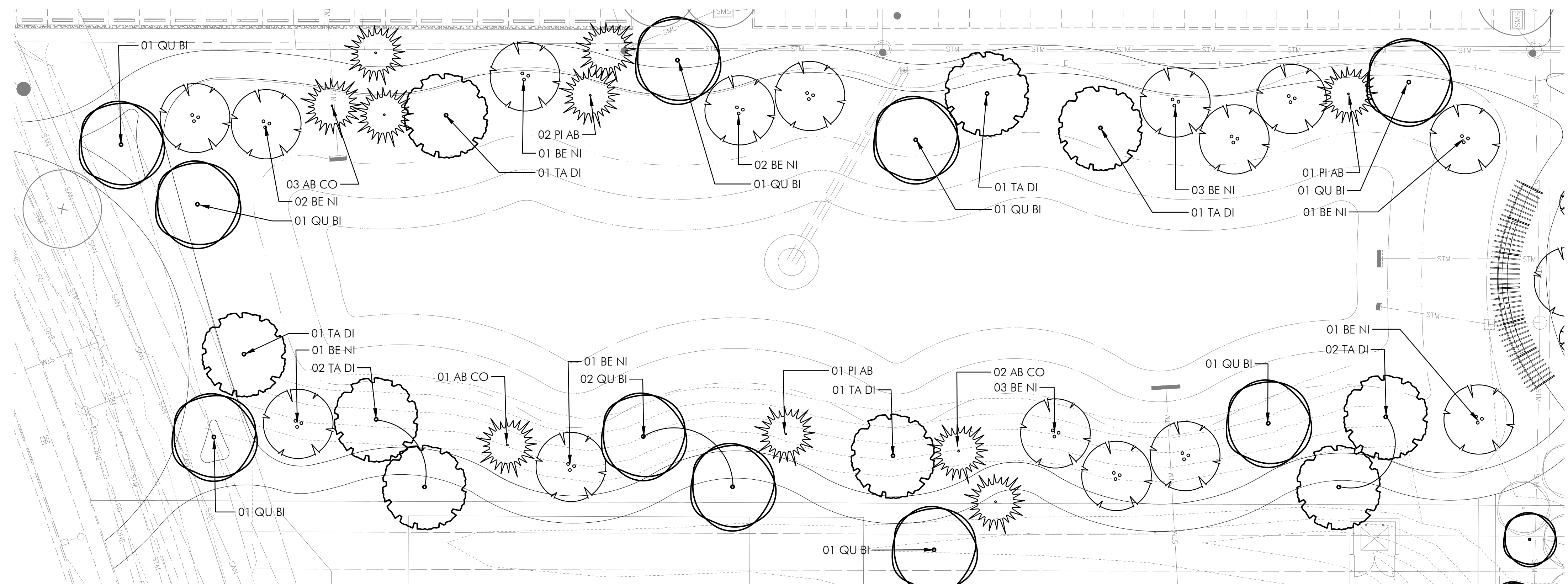

Pond Loop South Planting Plan
SCALE: 1" = 20'-0"

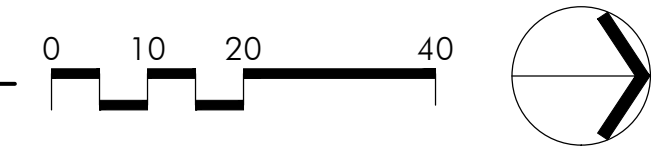

PLANTING LEGEND

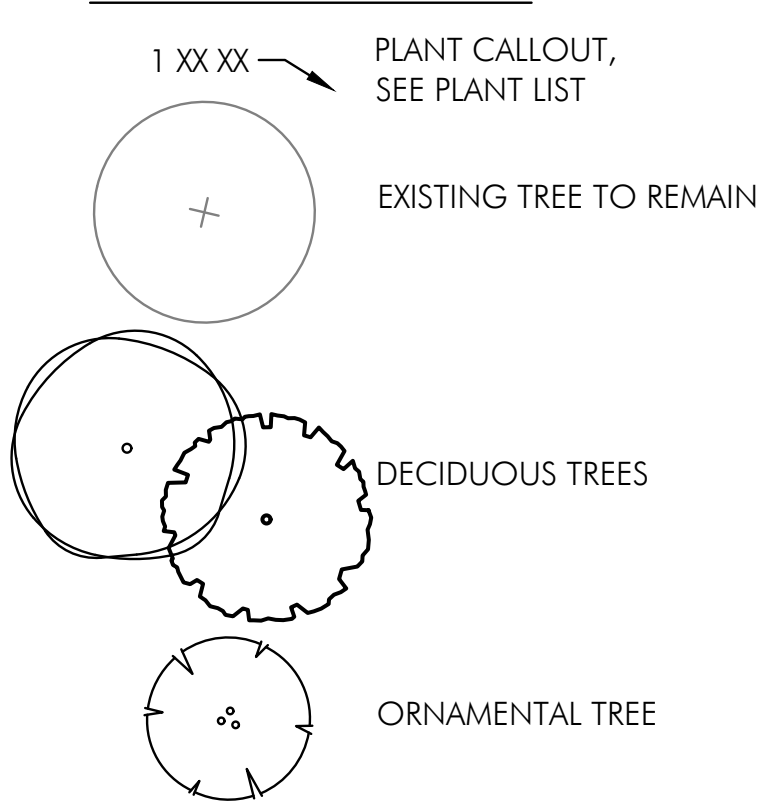

PLANT LIST

QTY.	SYMBOL	BOTANICAL & COMMON NAMES	SIZE	COND.	REMARKS
REPLACEMENT TREES					
	QU BI	Quercus bicolor Swamp White Oak	3" Cal.	B&B	
	TA DI	Taxodium distichum Baldcypress	3" Cal.	B&B	
DECIDUOUS TREES					
	BE NI	Betula nigra 'Dura-Heat' Dura Heat River Birch	15' Ht.	B&B	(3)Multi-stem 2" cal./stem
EVERGREEN TREES					
	AB CO	Abies concolor White Fir	10' ht.	B&B	
	PI AB	Picea abies Norway Spruce	10' ht.	B&B	
ORNAMENTAL TREES					
	CE CA	Cercis canadensis Eastern Redbud	10' ht.	B&B	(3)Multi-stem 2" cal./stem

NOTE: GROUND PLANE LAWN AROUND BASINS TO REMAIN.
SEED/REPAIR AS NECESSARY.

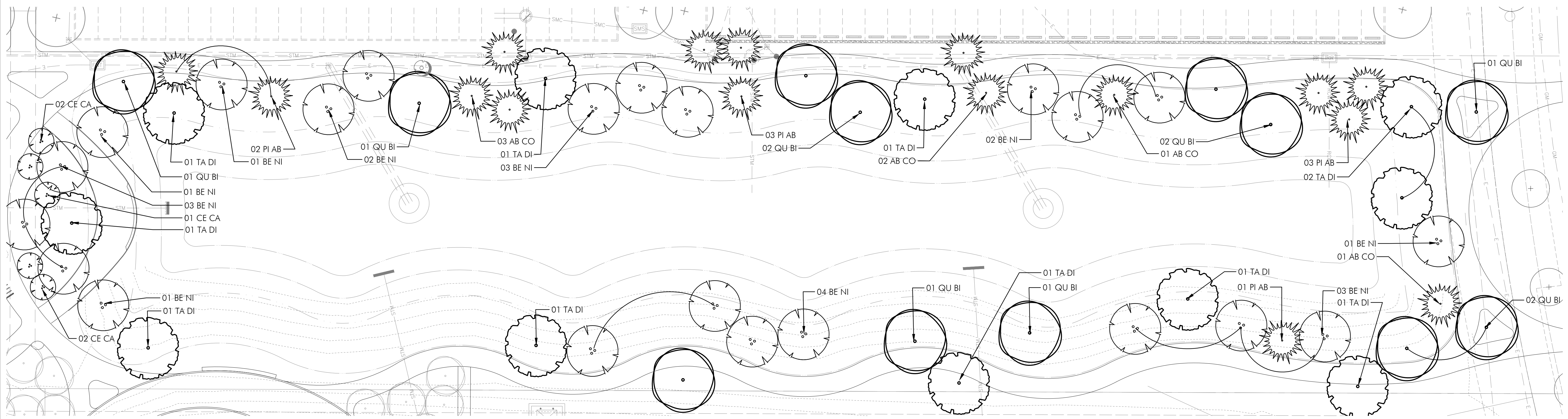

Pond Loop North Planting Plan
SCALE: 1" = 20'-0"

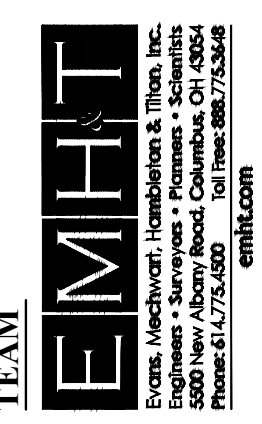
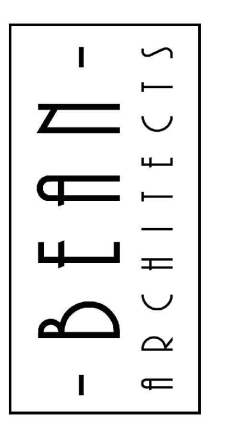

PREPARED FOR
DAMLER Group
1533 Lake Shore Dr. # 100,
Columbus, OH 43204



PROJECT NAME
The Corners - Park and Public Infrastructure
Frantz Road
Dublin, Ohio

PROJECT INFO
Project #: 20190873
By: SK/JW/AC
Date: 06/26/2020

SHEET TITLE
Pond Loops
Planting Plans

SHEET NUMBER
L-16

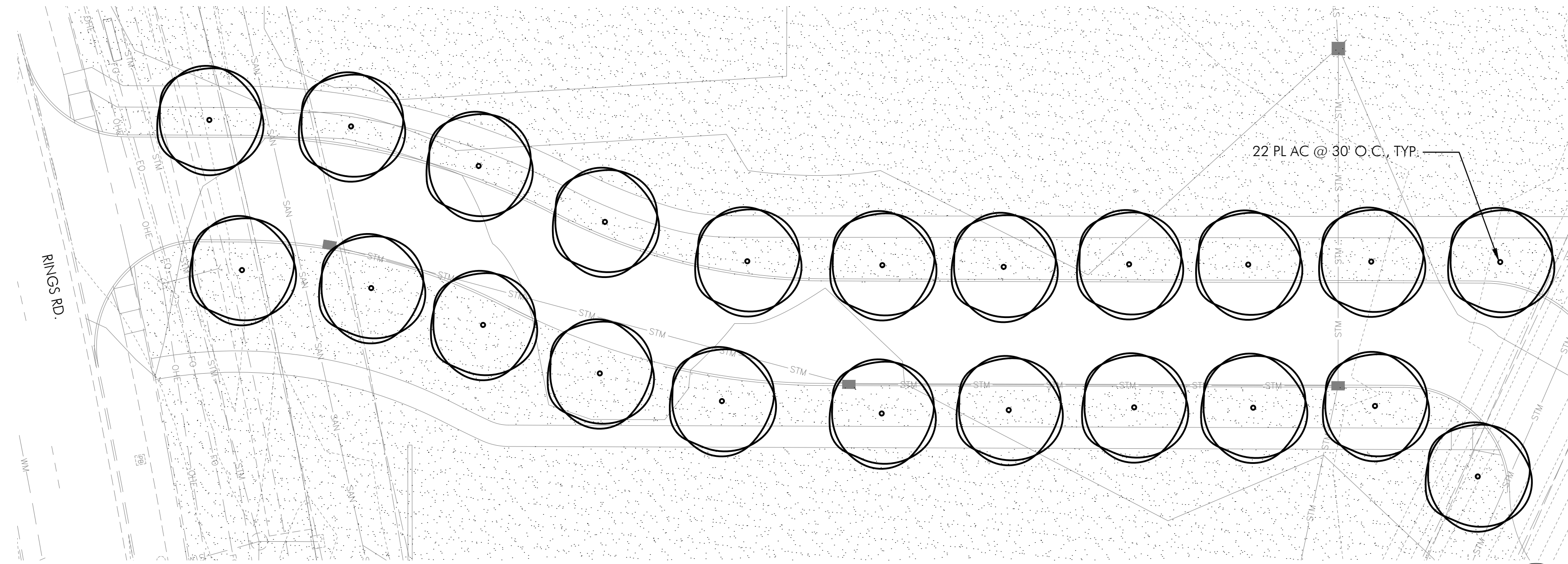

South Access Drive Planting Plan
SCALE: 1" = 20'-0"



North Access Drive Planting Plan
SCALE: 1" = 20'-0"

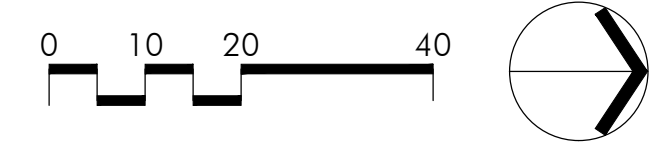

PLANTING LEGEND

- 1 XX XX → PLANT CALLOUT, SEE PLANT LIST
- EXISTING TREE TO REMAIN
- DECIDUOUS TREES
- SEEDED LAWN

PLANT LIST

QTY.	SYMBOL	BOTANICAL & COMMON NAMES	SIZE	COND.	REMARKS
REPLACEMENT TREES					
	PL AC	Platanus x acerifolia 'Morton Circle' Exclamation! London Planetree	3' Cal.	B&B	

POD Design
100 Northwoods Blvd, Ste A
Columbus, Ohio 43235
p 614.255.3399
pod@design.net



-BEAN-
ARCHITECTS

EMIT
EARTH ENGINEERING & INFRASTRUCTURE
Engineers • Surveyors • Planners • Scientists
1500 North High Street, Columbus, OH 43204
Phone: 614.775.6500
emit.com

PREPARED FOR
DAIMLER
Development • Leasing • Construction • Sales
Daimler Group
1533 Lake Shore Dr. # 100,
Columbus, OH 43204

PROJECT NAME
The Corners - Park and Public Infrastructure
Frantz Road
Dublin, Ohio

PROJECT INFO
Project #: 20190873
By: SK/JW/AC
Date: 06/26/2020

SHEET TITLE
Access Drives
Planting Plans

SHEET NUMBER
L-17

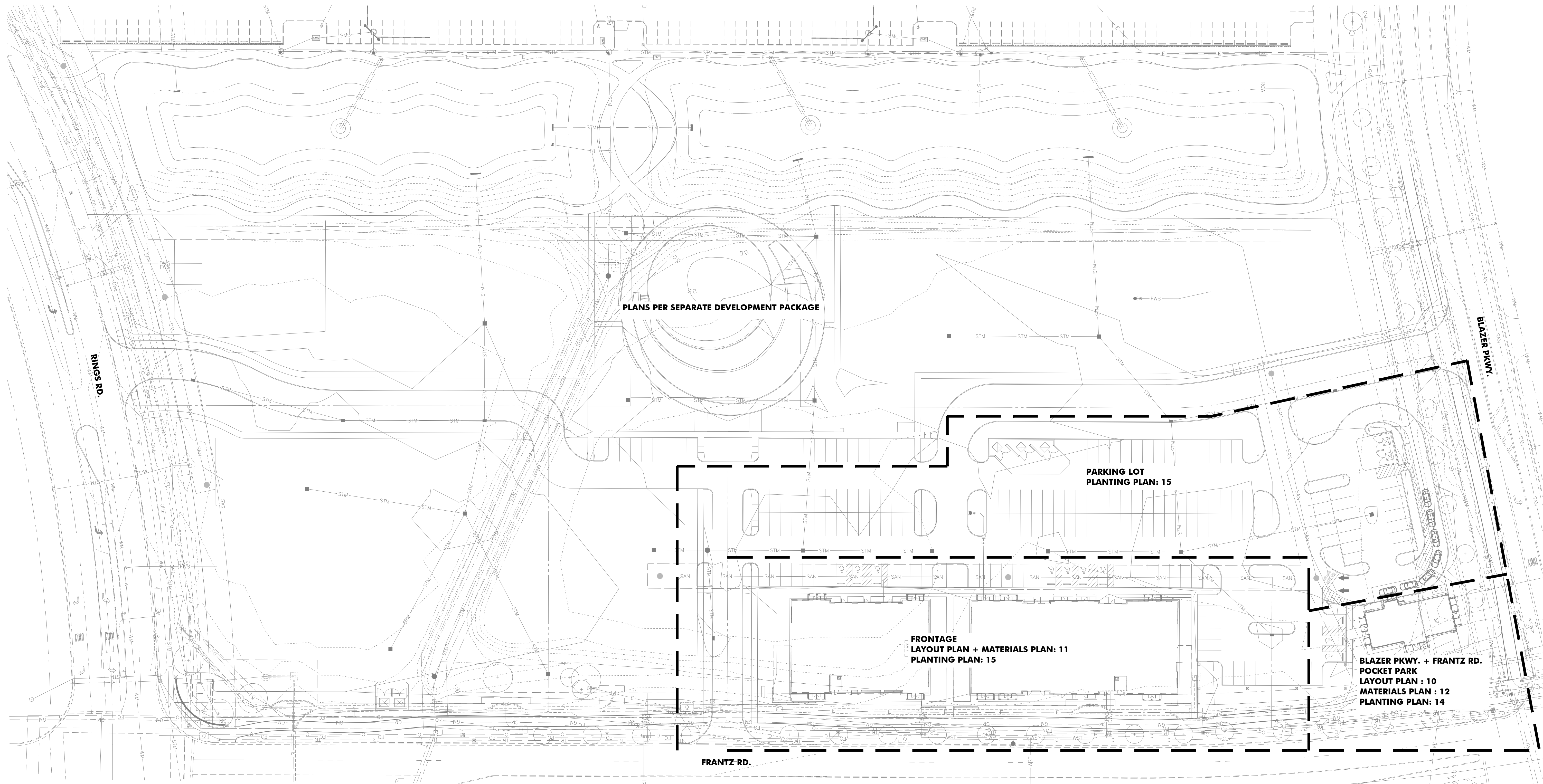

Site Reference Plan
SCALE: 1" = 40'-0"

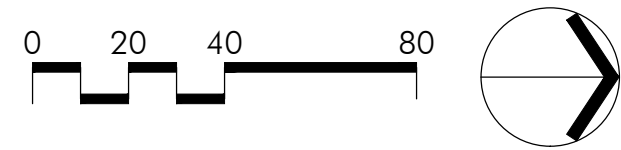

-BEAN-
ARCHITECTS

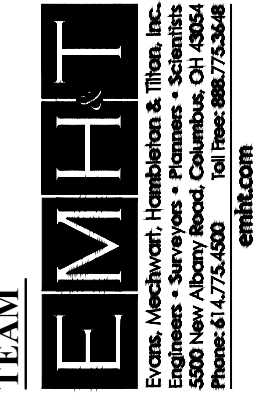

PREPARED FOR
DAIMLER
Development • Leasing • Construction • Sales
Daimler Group
1533 Lake Shore Dr # 100,
Columbus, OH 43204







PROJECT NAME
The Corners - Retail
Frantz Road
Dublin, Ohio

PROJECT INFO
Project #: 20190873
By: SK/AC
Date: 05/07/2020

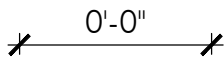
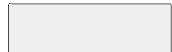
SHEET TITLE
Site Reference Plan

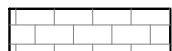
SHEET NUMBER
L-9

LAYOUT LEGEND

-  0'-0" LINEAR DIMENSION
-  ASPHALT TRAIL PER CIVIL PLANS
-  STANDARD CONCRETE PAVING SEE SHEET 12
-  ACCENT PAVING: SEE SHEET 12
-  PRE-CAST RETAINING WALL: SEE SHEET 12
-  WOOD BENCH : SEE SHEET 12
-  STONE ACCENT COLUMNS TO MATCH ARCH. SEE SHEET 12

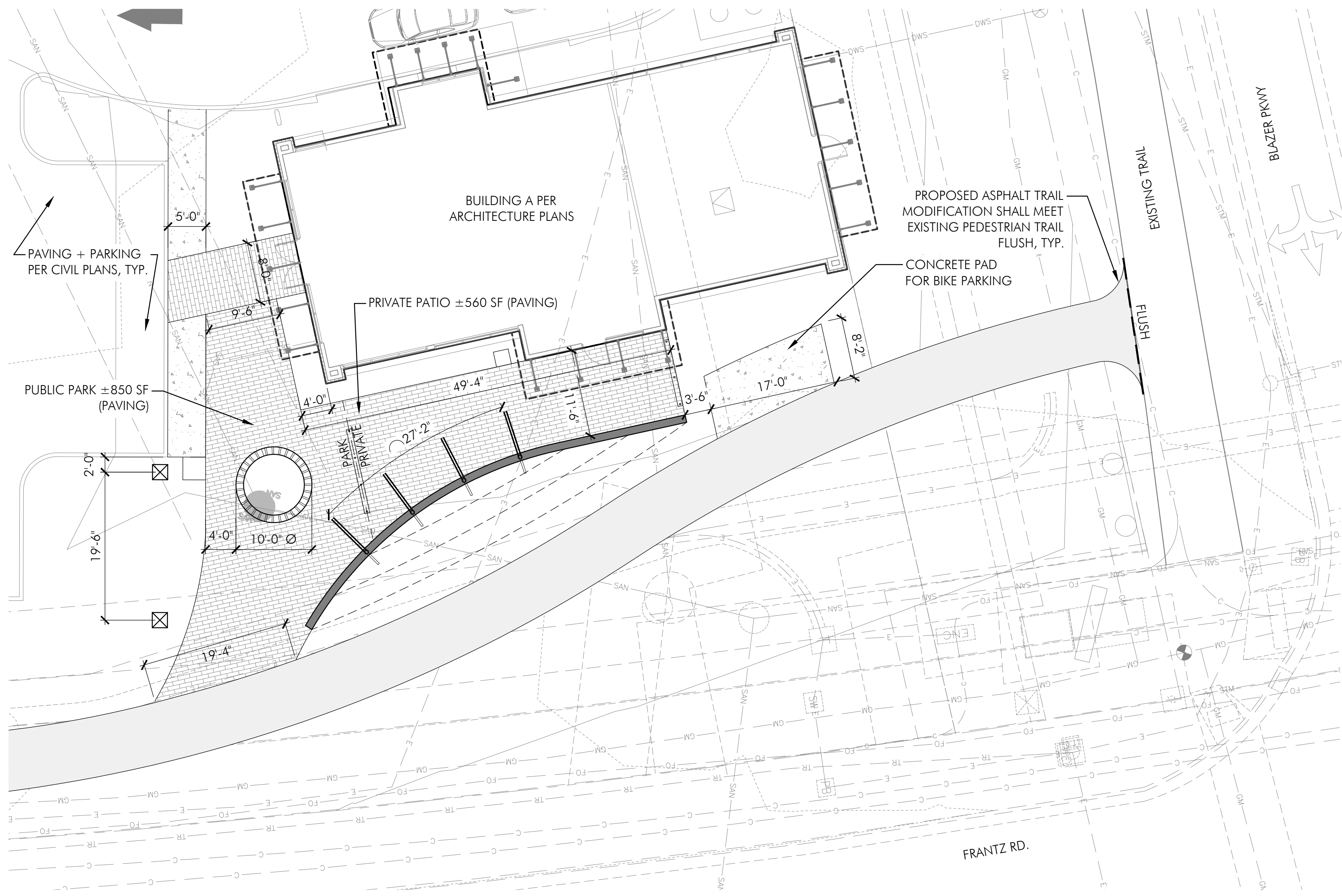

Blazer Pkwy. + Frantz Rd. Pocket Park Layout Plan
SCALE: 1" = 10'-0"

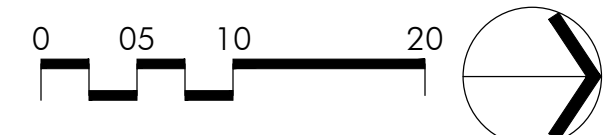

CONCEPTUAL IMAGES
IMAGES SHOWN FOR DESIGN INTENT ONLY : NOT TO SCALE



Blazer Pkwy. + Frantz Rd. Pocket Park



Blazer Pkwy. + Frantz Rd. Pocket Park

POD Design
100 Northwoods Blvd, Ste A
Columbus, Ohio 43235
p 614.255.3399
pod@design.net



BEAN-ARCHITECTS

TEAM
EMIT
Scott McWhorter, Hamilton A. Thib, Inc.
Engineers - Surveyors - Planners - Scientists
Professional Seal No. 03190000075804
emitll.com

PREPARED FOR
Daimler Group
1533 Lake Shore Dr. # 100,
Columbus, OH 43204
Daimler
Development • Leasing • Construction • Sales





PROJECT NAME
The Corners - Retail
Frantz Road
Dublin, Ohio

PROJECT INFO
Project #: 20190873
By: SK/AC
Date: 05/07/2020

SHEET TITLE
Blazer Pkwy. +
Frantz Rd. Pocket
Park Layout Plan

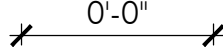
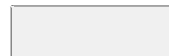
SHEET NUMBER
L-10

LAYOUT LEGEND

-  LINEAR DIMENSION
-  ASPHALT TRAIL PER CIVIL PLANS
-  STANDARD CONCRETE PAVING
-  STONE COLUMNS
SEE DETAIL, THIS SHEET
-  THEMATIC FENCE
SEE DETAIL, THIS SHEET

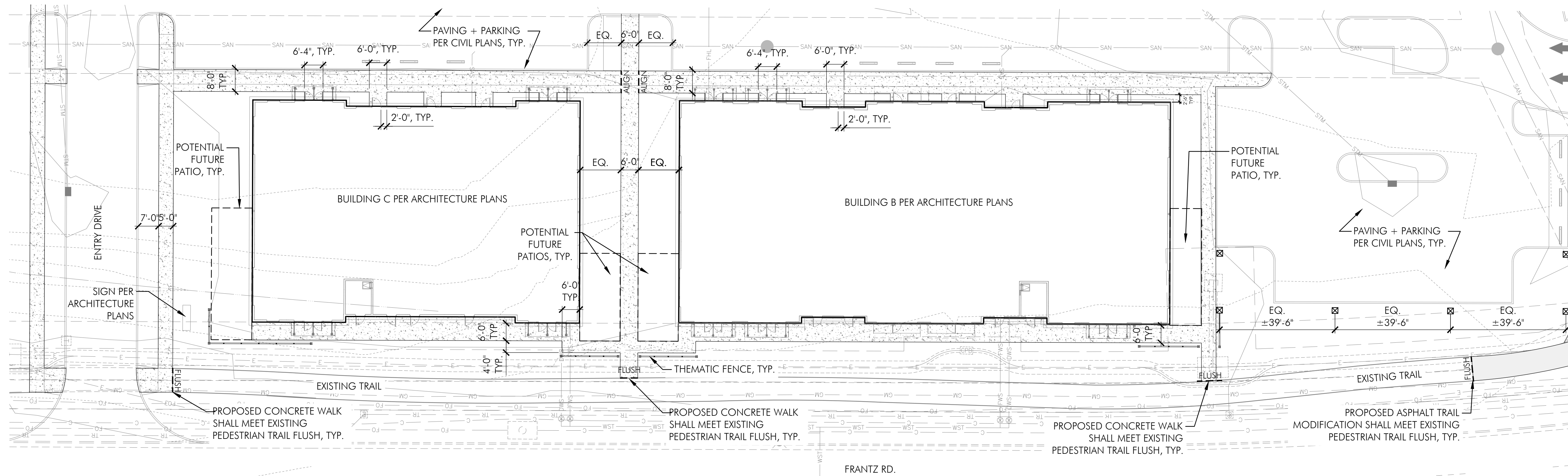

Frontage Layout Plan
SCALE: 1" = 20'-0"

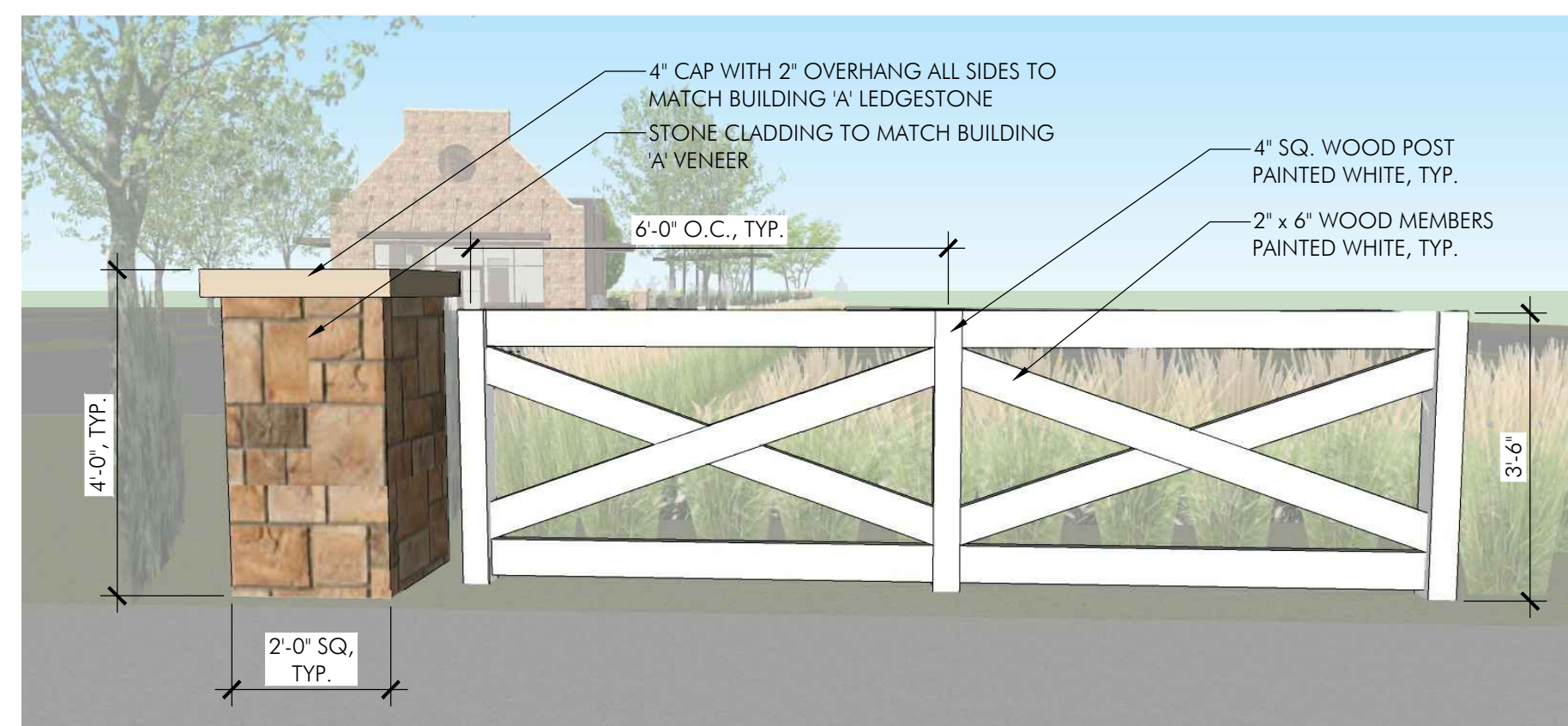
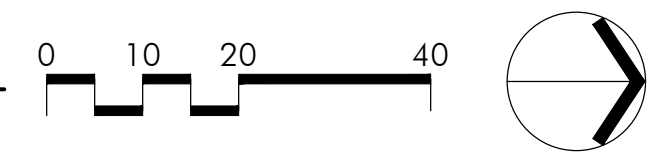

Stone Column & Thematic Fence
1/2" = 1'-0"



-BEAN-
ARCHITECTS

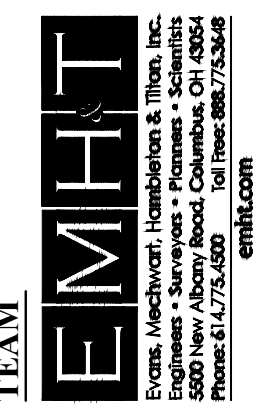

PREPARED FOR
DAIMLER
Development • Leasing • Construction • Sales
Daimler Group
1533 Lake Shore Dr. # 100,
Columbus, OH 43204

PROJECT NAME
The Corners - Retail
Frantz Road
Dublin, Ohio

PROJECT INFO
Project #: 20190873
By: SK/AC
Date: 05/07/2020

SHEET TITLE
Frontage Layout
Plan





SHEET NUMBER

L-11

FURNISHINGS CODED NOTES

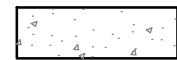
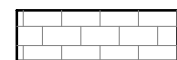
1. PATIO FURNISHINGS (TABLES + CHAIRS, TRASH RECEPTACLE, ETC.) BY OWNER
2. ACCENT STRUCTURE SEE DETAIL, THIS SHEET
3. LEAN RAIL, TYP. OF (2) SEE MATERIALS SCHEDULE
4. TRASH RECEPTACLE, TYP. OF (1) SEE MATERIALS SCHEDULE
5. BIKE RACKS, TYP. OF (6) PER CODE SEE MATERIALS SCHEDULE
6. BENCHES BY OWNER

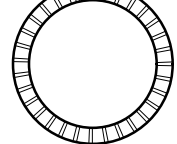
MATERIALS LEGEND:

-  ASPHALT TRAIL PER CIVIL PLANS
-  STANDARD CONCRETE PAVING
-  ACCENT PAVING: SEE MATERIALS SCHEDULE
-  PRE-CAST RETAINING WALL: SEE MATERIALS SCHEDULE
-  WOOD BENCH: SEE MATERIALS SCHEDULE
-  STONE ACCENT COLUMNS TO MATCH ARCH. SEE DETAIL, THIS SHEET

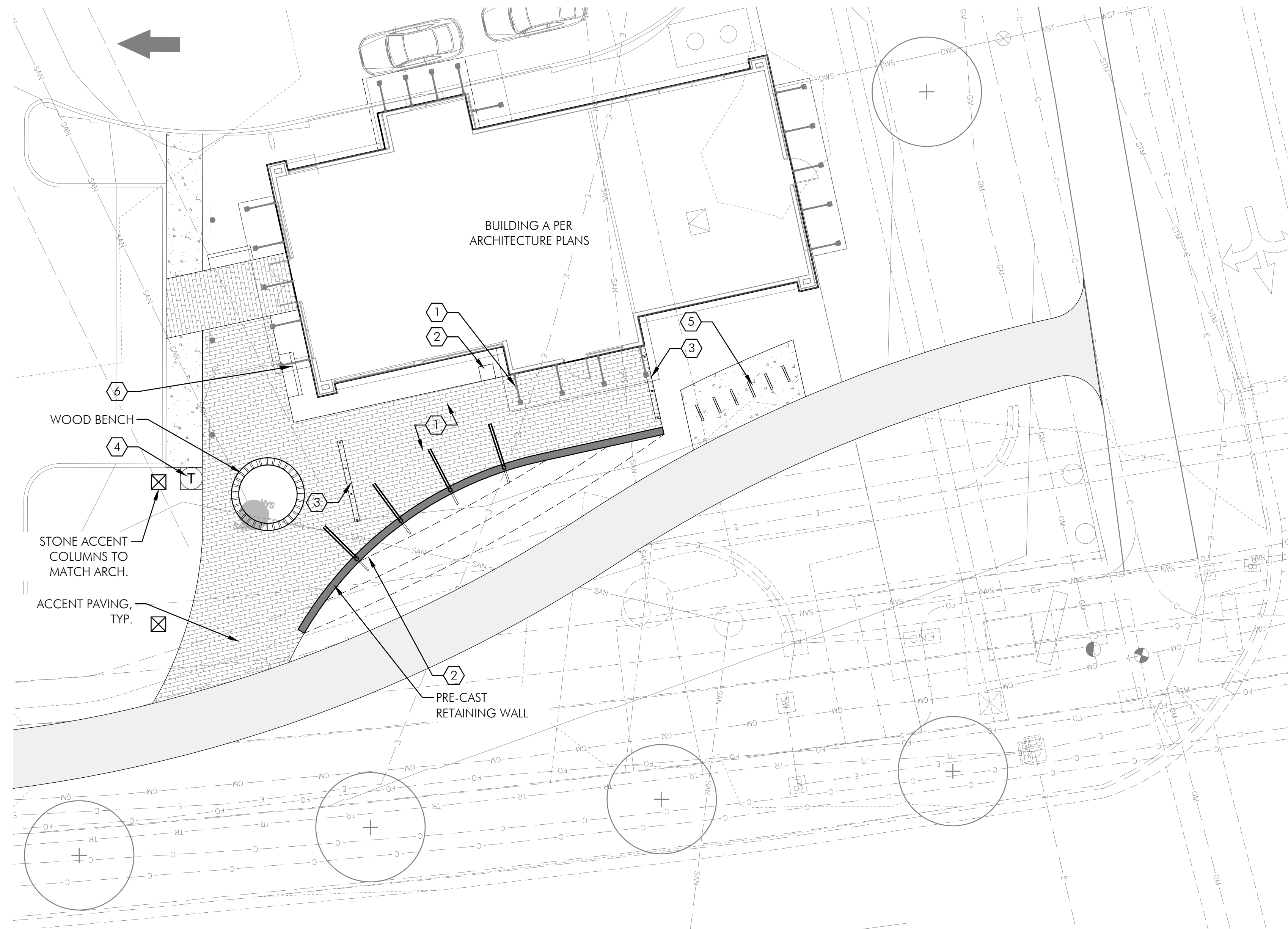

MATERIALS SCHEDULE FURNISHINGS



LEAN RAIL
 DESCRIPTION : JESSIE
 COLOR / FINISH : POWDERCOATED STORMCLOUD
 MOUNT : EMBEDDED
 QUANTITY : 2
 LANDSCAPE FORMS
 P. 269-276-4440
 WWW.LANDSCAPEFORMS.COM



TRASH RECEPTACLES
 DESCRIPTION : STEELSITES
 COLOR / FINISH : BLACK
 MOUNT : EMBEDDED
 MODEL # : A-45 GALLON
 QUANTITY : 1
 VICTOR STANLEY
 P. 301-855-8300
 WWW.VICTORSTANLEY.COM



BIKE RACKS
 DESCRIPTION : RIDE BIKE RACK
 COLOR / FINISH : POWDERCOATED STORMCLOUD
 MOUNT : EMBEDDED
 QUANTITY : 6
 LANDSCAPE FORMS
 P. 269-276-4440
 WWW.LANDSCAPEFORMS.COM

NOTE:
 ALL FURNISHINGS + FINISHES
 PENDING APPROVAL PER FINAL
 DEVELOPMENT PLANS

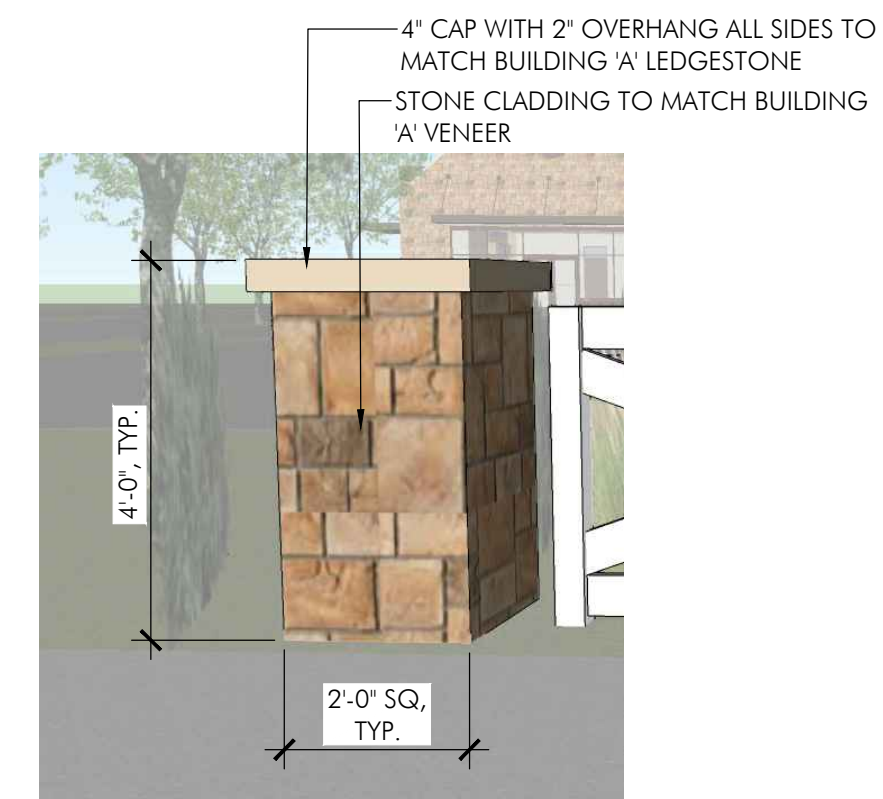

Typical Stone Column
 1/2" = 1'-0"

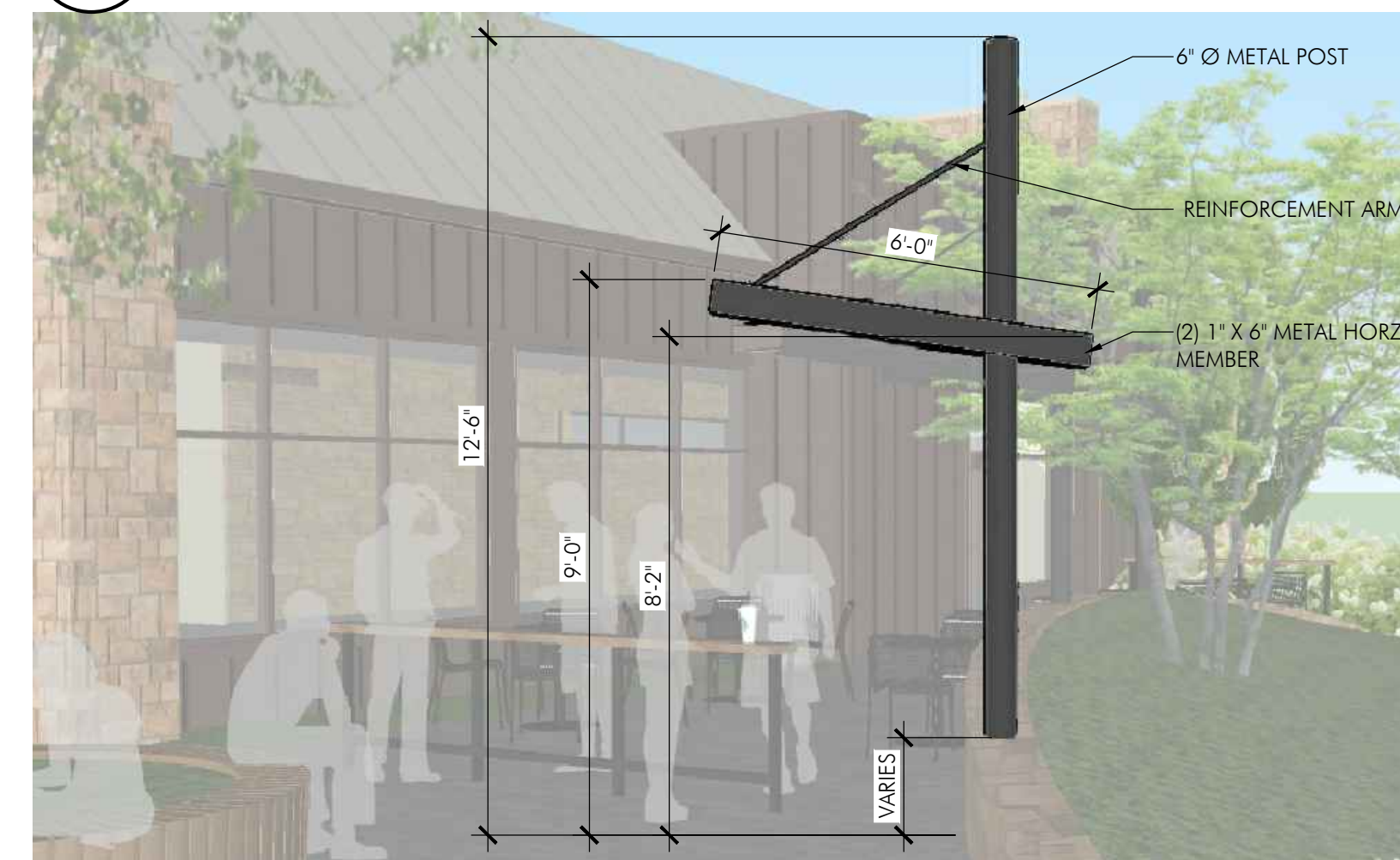

Accent Structure
 3/8" = 1'-0"

HARDSCAPE

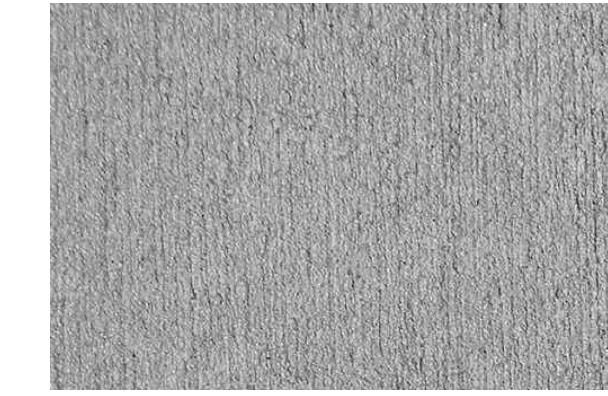

STANDARD CONCRETE PAVING
 COLOR / FINISH : NATURAL GREY
 LIGHT BROOM FINISH



ACCENT PAVING
 DESCRIPTION : ECO PREMIER PAVERS
 COLOR / FINISH : GREY BLEND
 HEP-10, HEP-20
 SIZE : 6" x 24"
 QUANTITY : 9,990 SF

TECTURA DESIGNS
 CONTACT : BRYAN HENNE
 P. 412-445-4898
 WWW.TECTURADESIGNS.COM



PRE-CAST CONCRETE (SEAT + RETAINING WALLS)
 DESCRIPTION : PRE-CAST CONCRETE UNITS
 COLOR / FINISH : W31

WAUSAU TILE
 CONTACT : BRYAN HENNE
 P. 412-445-4898
 WWW.WAUSAUTILE.COM



WOOD BENCH
 COLOR / FINISH : THERMALLY MODIFIED ASH
 QUANTITY : ±32 LF

LANDSCAPE FORMS
 P. 269-276-4440
 WWW.LANDSCAPEFORMS.COM

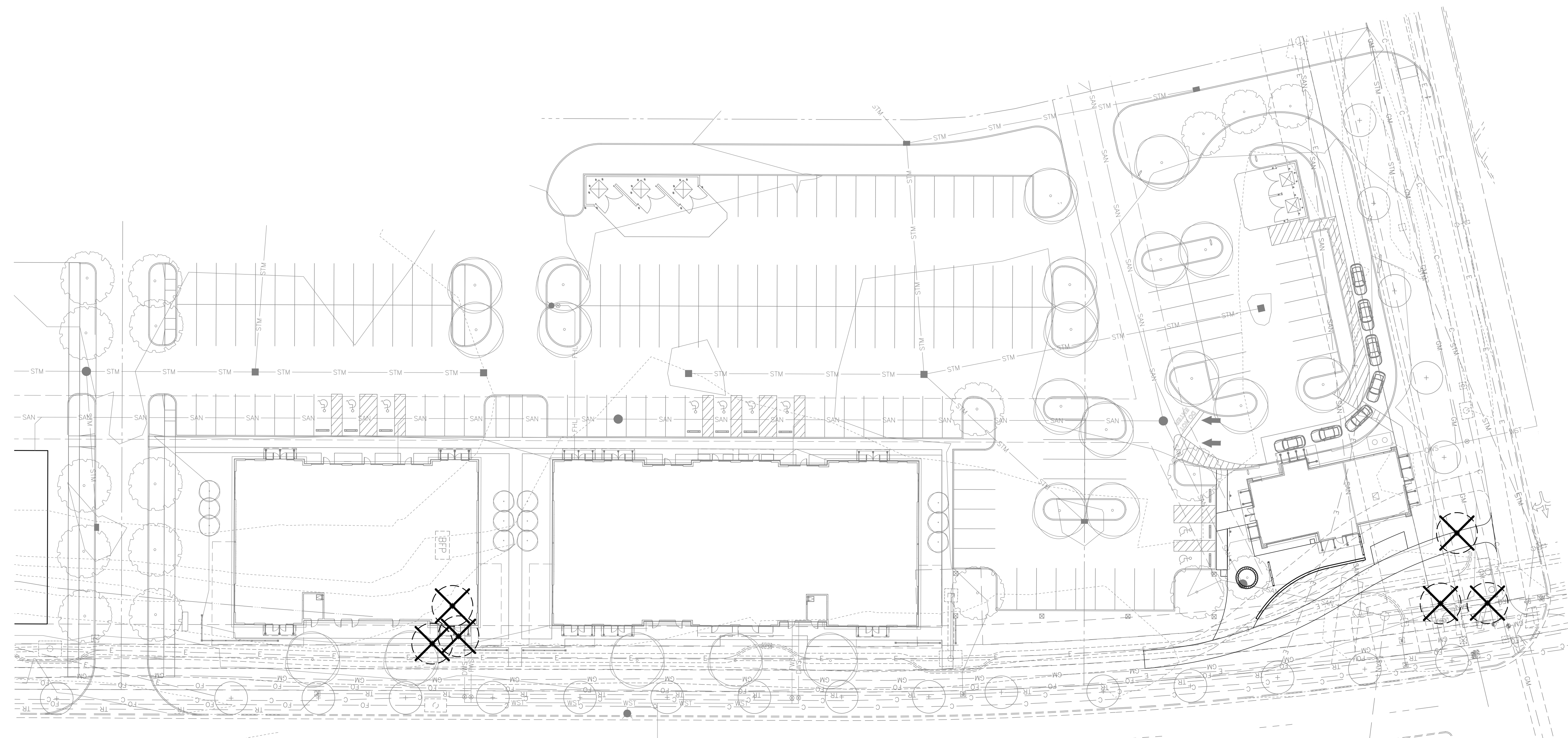

PLANTING LEGEND

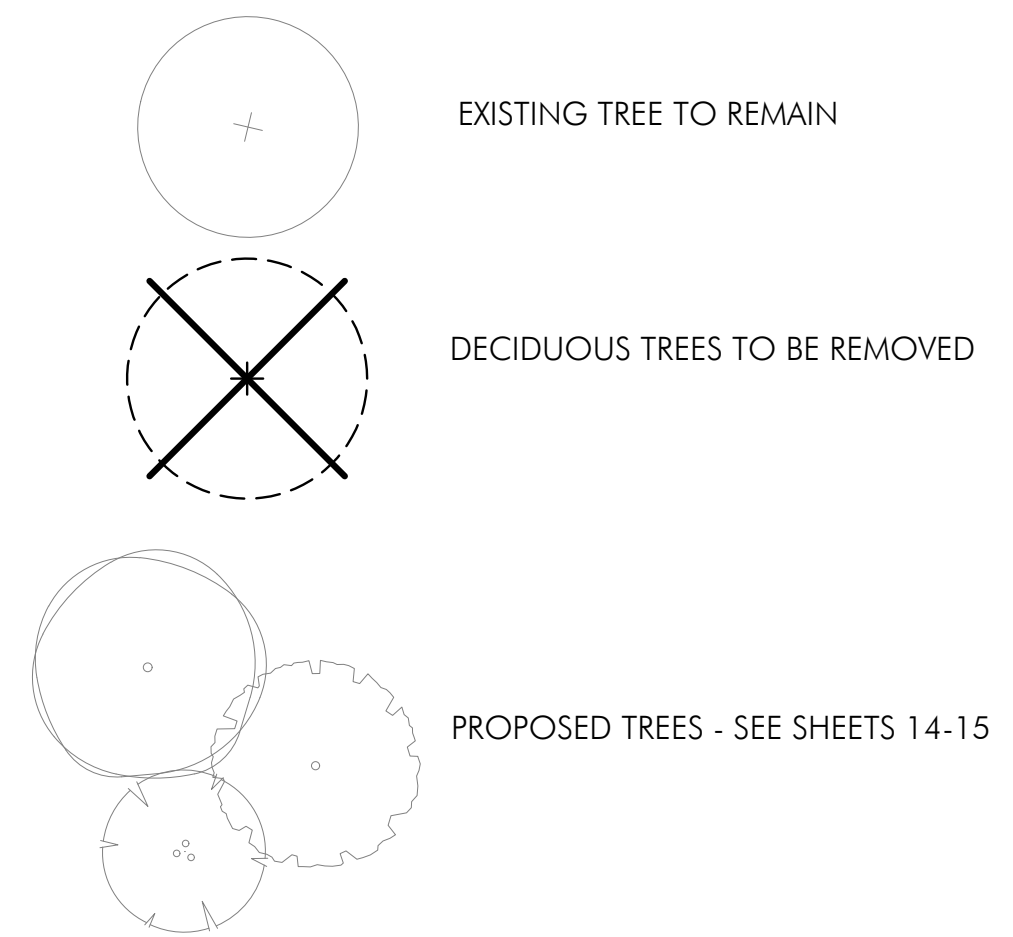

TREE REPLACEMENT + CODE REQUIREMENTS:

TREE REPLACEMENT

TOTAL CALIPER INCHES TO BE REMOVED : ±35"
(3 TREES UNDER 6" CALIPER, 3 TREE AT/ABOVE 6" CALIPER)

TOTAL CALIPER INCHES TO BE REPLACED : ±35"

TOTAL CALIPER INCHES PROPOSED : 37.5" (15 TREES @ 2.5" CALIPER)

CODE FULFILLMENT (DOES NOT INCLUDE REPLACEMENT TREES)

REQUIRED: ±114,000 SF GROUND COVERAGE / 5,000 = 23 TREES
PROVIDED : 37 TREES

Tree Replacement Plan
SCALE: 1" = 30'-0"

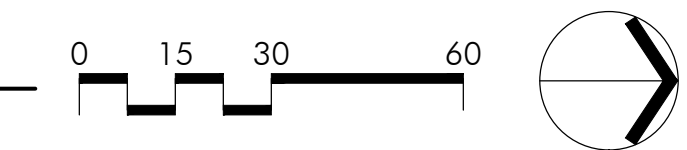

POD Design
100 Northwoods Blvd, Ste A
Columbus, Ohio 43235
p 614.255.3399
pod@design.net



-BEAN-
ARCHITECTS

TEAM
EMHT
Estate, Mechanical, Hazardous & Toxic, Inc.
Engineers - Surveyors - Planners - Scientists
15000 W. Dublin Road, Suite 400
Dublin, OH 43017
Phone: 614.772.6520
emht.com

PREPARED FOR
DAIMLER
Development • Leasing • Construction • Sales

Daimler Group
1533 Lake Shore Dr. # 100,
Columbus, OH 43204

PROJECT NAME
The Corners - Retail
Frantz Road
Dublin, Ohio

PROJECT INFO
Project #: 20190873
By: SK/AC
Date: 06/25/2020

SHEET TITLE
Tree Replacement
Plan

SHEET NUMBER
L-13

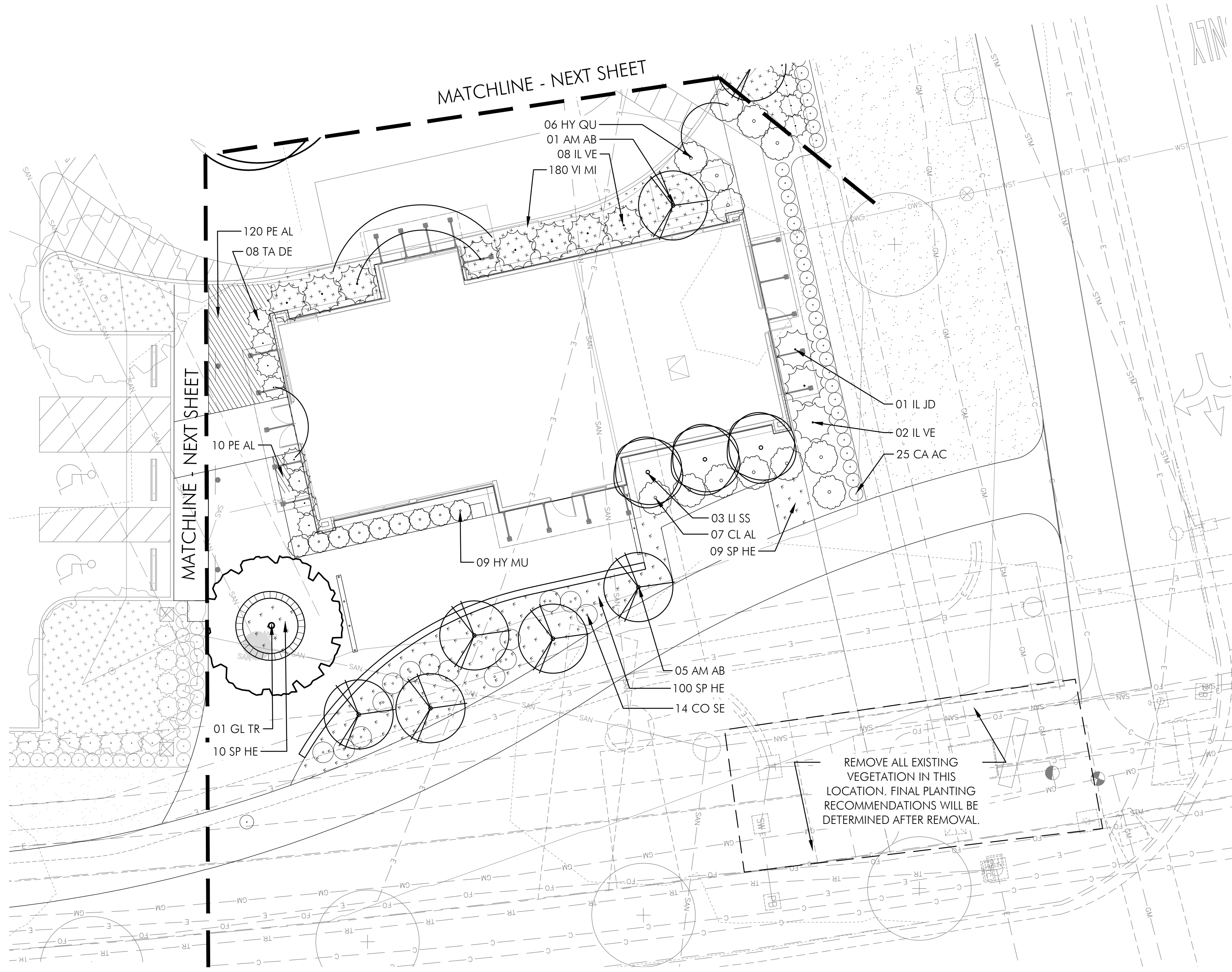

PLANTING LEGEND

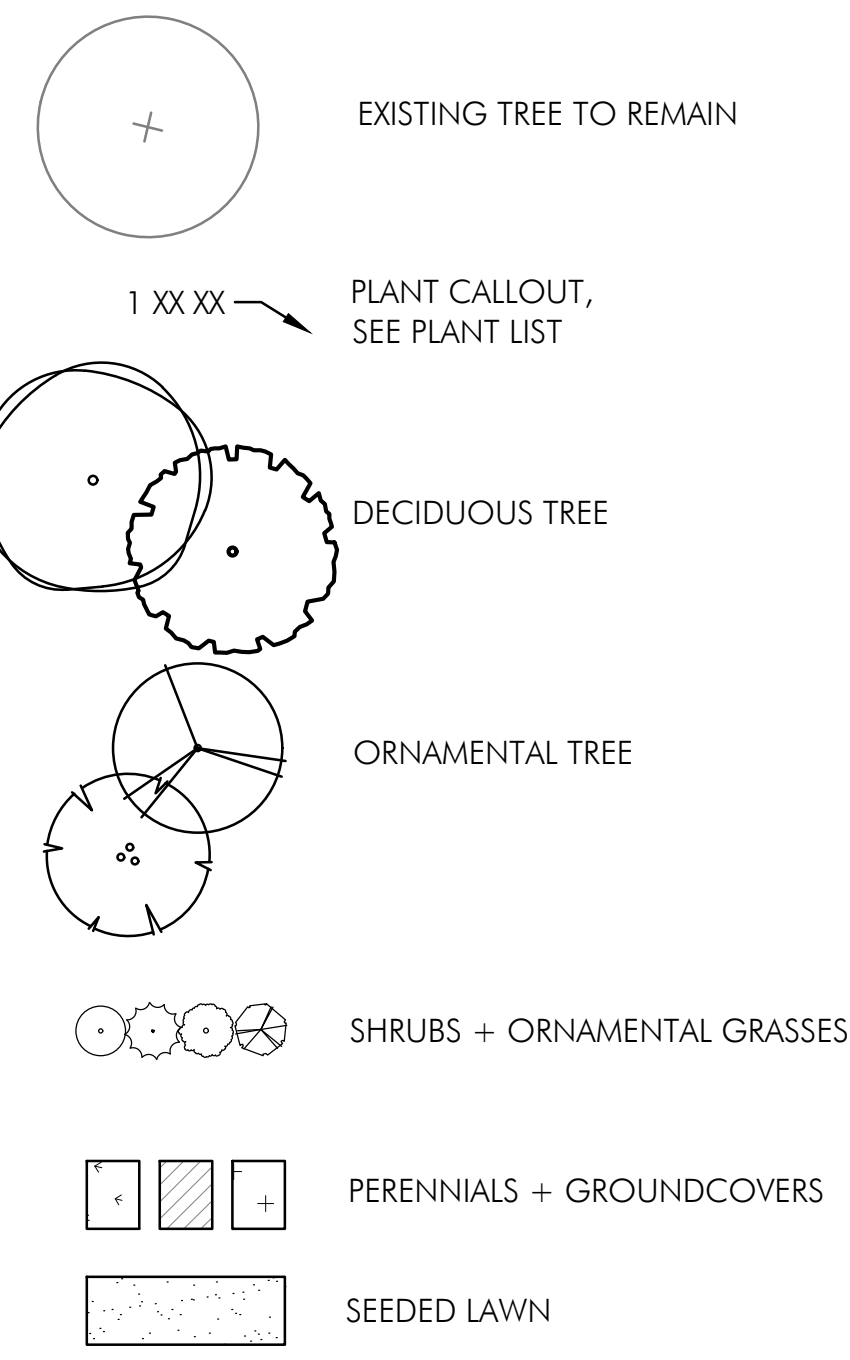

PLANT LIST

QTY.	SYMBOL	BOTANICAL & COMMON NAMES	SIZE	COND.	REMARKS
REPLACEMENT TREES					
	LI SS	Liquidambar styraciflua 'Slender Silhouette' Slender Silhouette Sweetgum	3" Cal.	B&B	
DECIDUOUS TREES					
	GL TR	Gleditsia triacanthos var. inermis 'Shademaster' Shademaster Thornless Honeylocust	3" Cal.	B&B	
ORNAMENTAL TREES					
	AM AB	Amelanchier x grandiflora 'Autumn Brilliance' Apple Serviceberry	10' ht.	B&B	(3)/Multi-stem 2" cal./stem
SHRUBS					
	CL AL	Clethera alnifolia 'Hummingbird' Hummingbird Summersweet	24" ht.	#5 cont.	AS SHOWN
	CO SE	Cornus sericea 'Farrow' Arctic Fire® Red Twig Dogwood	24" ht.	#3 cont.	AS SHOWN
	HY MU	Hydrangea quercifolia 'Munchkin' Munchkin Oakleaf Hydrangea	24" ht.	#3 cont.	AS SHOWN
	HY QU	Hydrangea quercifolia 'Snow Queen' Oakleaf Hydrangea	24" ht.	#3 cont.	AS SHOWN
	IL JD	Ilex verticillata 'Jim Dandy' Jim Dandy Winterberry (Male)	24" ht.	#5 cont.	AS SHOWN
	IL VE	Ilex verticillata 'Red Sprite' Red Sprite Winterberry	24" ht.	#5 cont.	AS SHOWN
PERENNIALS/ ORNAMENTAL GRASSES/ GROUNDCOVERS					
	CA AC	Calamagrostis x acutiflora 'Karl Foerster' Feather Reed Grass	Clump	#1 cont.	24" o.c.
	PE AL	Pennisetum alopecuroides 'Little Bunny' Little Bunny Fountain Grass	Clump	#1 cont.	10" o.c.
	SP HE	Sporobolus heterolepis Prairie Dropseed	Clump	#1 cont.	30" o.c.
	VI MI	Vinca minor 'Alba' White Periwinkle	Clump	#1 cont.	18" o.c.

Blazer Pkwy. + Frantz Rd. Pocket Park Planting Plan
SCALE: 1" = 10'-0"

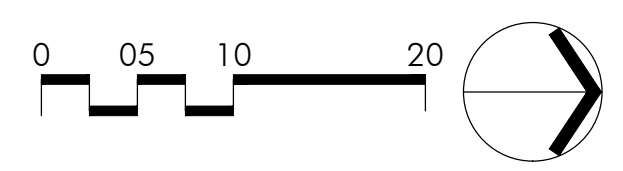

POD Design
100 Northwoods Blvd., Ste. A
Columbus, Ohio 43235
p 614.255.3399
pod@design.net



BEAN-ARCHITECTS

TEAM
EMIT
Scott McWhorter, Hamilton A. Tritt, Inc.
Engineers - Surveyors - Planners - Scientists
Professional Seal No. 17725-0001
emit.com

PREPARED FOR
Daimler Group
1533 Lake Shore Dr. # 100,
Columbus, OH 43204
DAIMLER
Development • Leasing • Construction • Sales

PROJECT NAME
The Corners - Retail
Frantz Road
Dublin, Ohio

PROJECT INFO
Project #: 20190873
By: SK/AC
Date: 06/25/2020

SHEET TITLE
Blazer Pkwy. +
Frantz Rd. Pocket
Park Planting Plan

SHEET NUMBER

L-14

QTY.	SYMBOL	BOTANICAL & COMMON NAMES	SIZE	COND.	REMARKS
REPLACEMENT TREES					
	CA BE	Carpinus betulus 'Frans Fontaine' Columnar European Hornbeam	3" Cal.	B&B	AS SHOWN
DECIDUOUS TREES					
	GL TR	Gleditsia triacanthos var. inermis 'Shademaster' Shademaster Thornless Honeylocust	3" Cal.	B&B	
	LI TU	Liriodendron tulipifera Tulip Tree	2" Cal.	B&B	AS SHOWN
	PL AC	Platanus x acerifolia London Planetree	2" Cal.	B&B	AS SHOWN
ORNAMENTAL TREES					
	AM AB	Amelanchier x grandiflora 'Autumn Brilliance' Apple Serviceberry	10' ht.	B&B	(3)Multi-stem 2" cal./stem
SHRUBS					
	HY PA	Hydrangea paniculata 'Little Lamb' Panicle Hydrangea	24" ht.	#3 cont.	AS SHOWN
	HY QU	Hydrangea quercifolia 'Snow Queen' Oakleaf Hydrangea	24" ht.	#3 cont.	AS SHOWN
	TA DE	Taxus x media 'Densiformis' Dense Yew	24" ht.	#5 cont.	AS SHOWN
	TA HI	Taxus x media 'Hicksii' Hick's Yew	24" ht.	#5 cont.	AS SHOWN
PERENNIALS/ ORNAMENTAL GRASSES/ GROUNDCOVERS					
	CA AC	Calamagrostis x acutiflora 'Karl Foerster' Feather Reed Grass	Clump	#1 cont.	24" o.c.
	EC CL	Echinacea 'Coconut Lime' Coconut Lime Coneflower	Clump	#1 cont.	24" o.c.
	LI SP	Liriope spicata Creeping Liriope	Clump	#1 cont.	18" o.c.
	NA DM	Narcissus 'Dutch Master' Daffodil	Bulb		12" o.c.
	NE FA	Nepeta x faassenii 'Walker's Low' Walker's Low Catmint	Clump	#1 cont.	24" o.c.
	PA TE	Pachysandra terminalis Pachysandra	Clump		12" o.c.
	PE HA	Pennisetum alopecuroides 'Hameln' Dwarf Fountain Grass	Clump	#1 cont.	24" o.c.

PLANTING LEGEND

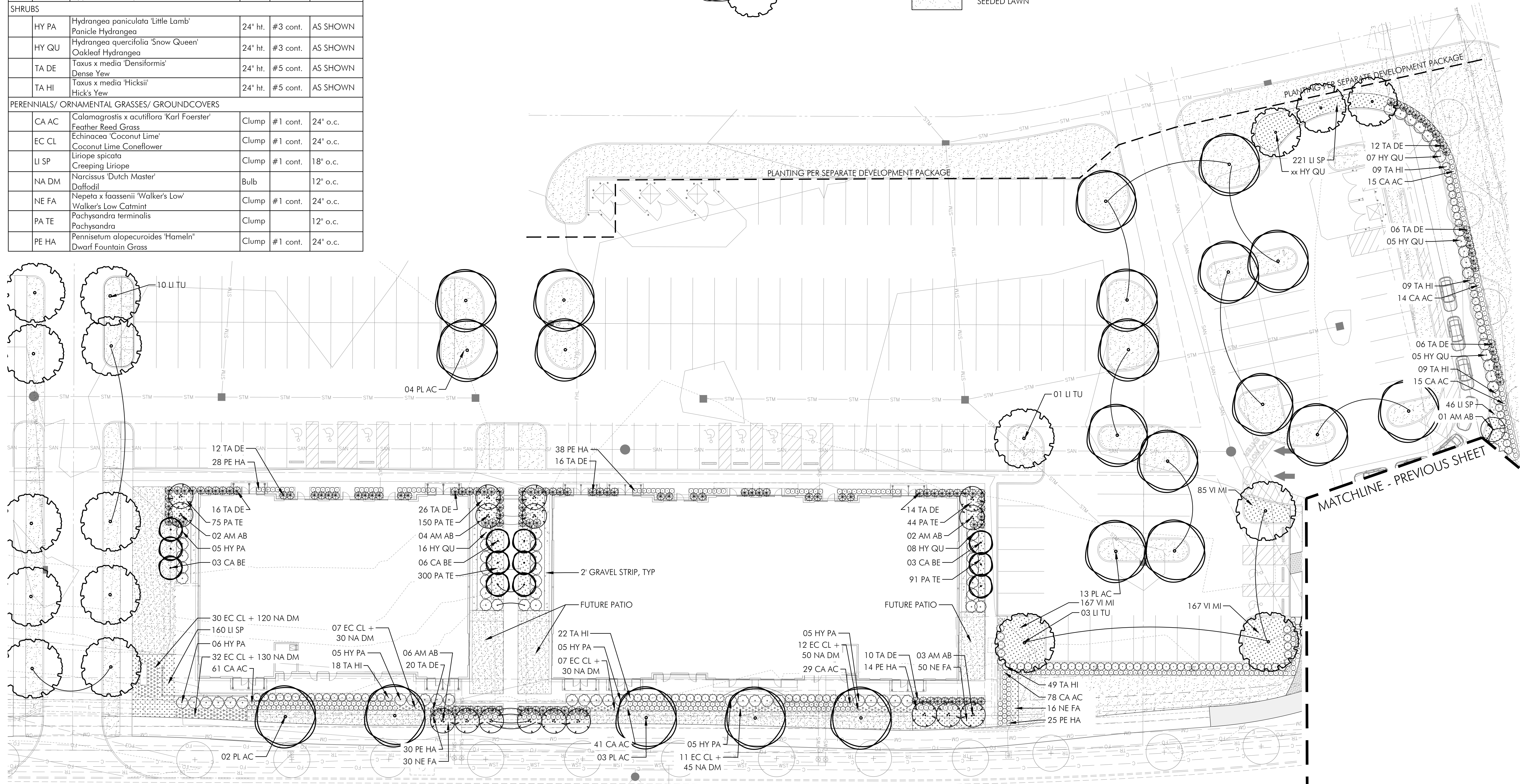
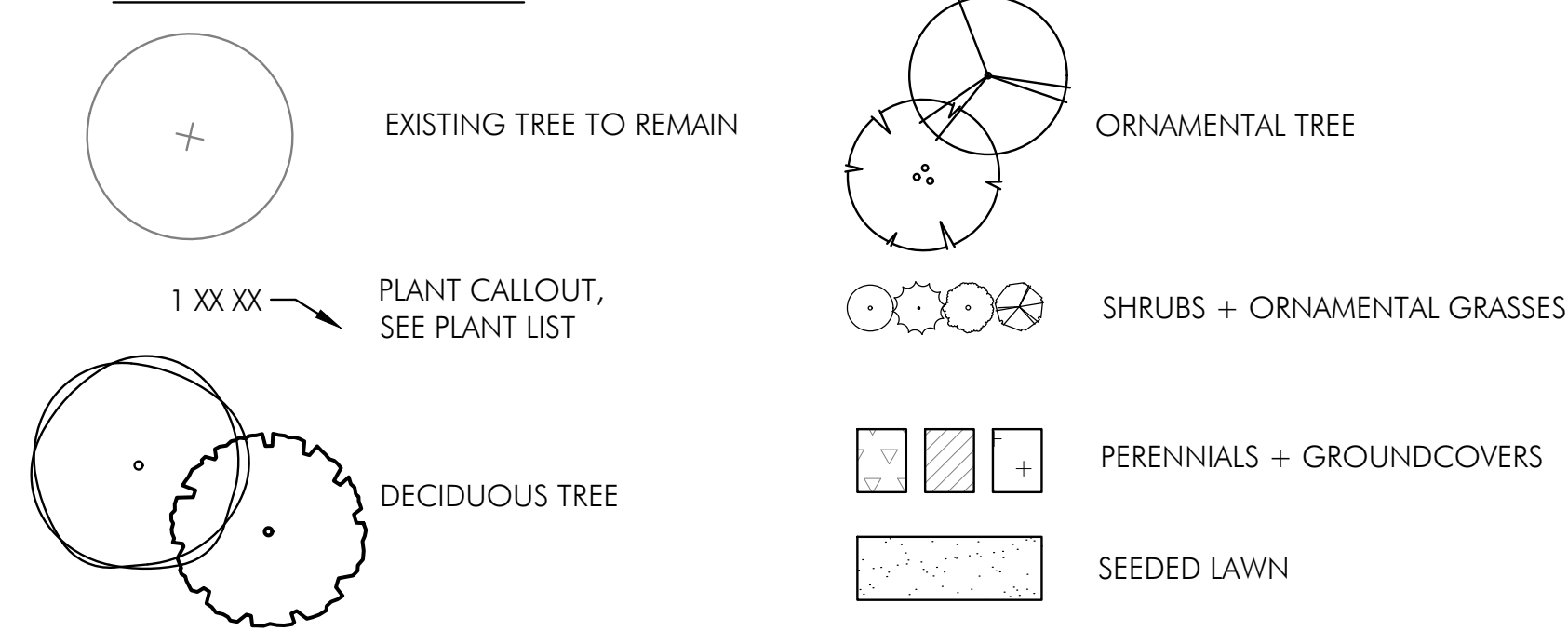

Frontage Planting Plan
SCALE: 1" = 20'-0"

