





614.503.1450  
 DKARCHUS  
 2960 COLUMBUS PIKE  
 DELAWARE, OH 43015

6632 LONGSHORE ST, BLDG C3  
 DUBLIN, OHIO 43217

Project Number: 19023  
 Drawn By: PF  
 Date: 5/14/2021

A001

**GENERAL STRUCTURAL NOTES**

**GENERAL**

- IT IS SOLELY THE CONTRACTOR'S RESPONSIBILITY TO DETERMINE ERECTION PROCEDURE AND SEQUENCE AND TO INSURE THE SAFETY OF THE BUILDING AND ITS COMPONENT PARTS DURING CONSTRUCTION. THIS INCLUDES THE ADDITION OF WHATEVER SHORING, SHEETING, TEMPORARY BRACING OR TIEDOWNS WHICH MIGHT BE NECESSARY. SUCH MATERIAL SHALL REMAIN THE CONTRACTOR'S PROPERTY AFTER COMPLETION OF THE PROJECT.
- IT IS SOLELY THE CONTRACTOR'S RESPONSIBILITY TO FOLLOW ALL APPLICABLE SAFETY CODES AND REGULATIONS DURING ALL PHASES OF CONSTRUCTION.
- SHOULD ANY OF THE DETAILED INSTRUCTIONS SHOWN ON THE PLANS CONFLICT WITH THE GENERAL STRUCTURAL NOTES, THE SPECIFICATIONS OR WITH EACH OTHER, THE STRICTEST PROVISION SHALL GOVERN.

**SCOPE OF WORK-IMPROVEMENTS**

SCOPE: OVERHEAD DOORS ARE BEING ADDED TO THE EXISTING STORFRONT SYSTEM NEAR THE MAIN ENTRY.

**CODE DATA**

**USE GROUP CLASSIFICATION (300.00)**  
 USE GROUP A-2 (UNCHANGED)

**BUILDING HEIGHTS AND AREAS (503.0)**  
 USE GROUP A-2 (UNCHANGED)

ACTUAL 5 STORIES, 17,438 SF < UNLIMITED SF AREA (UNCHANGED)  
 ALLOWABLE 2 STORIES, UNLIMITED AREA  
 AREA OF WORK **NEW AREAS - 31 SF**

**MIXED USE AND OCCUPANCY (508.0)**  
 MIXED USE / NONSEPARATED (UNCHANGED)

**CONSTRUCTION CLASSIFICATION (601.0)**  
 TYPE IA SPRINKLERED (UNCHANGED)

**AUTOMATIC SPRINKLER SYSTEMS (903.0)**  
 AUTOMATIC SPRINKLER SYSTEM PROVIDED FOR RESTAURANT (UNCHANGED)

**PORTABLE FIRE EXTINGUISHERS (906)**  
 PORTABLE FIRE EXTINGUISHERS PROVIDED  
 COORDINATE LOCATIONS W/ LOCAL INSPECTOR W/ MAX TRAVEL DISTANCE TO UNIT OF 75'-0" REFER TO EGRESS & FLOOR PLAN FOR LOCATIONS

**FIRE ALARM AND DETECTION SYSTEMS (907)**  
 FIRE ALARM AND DETECTION SYSTEM PROVIDED (UNCHANGED)

**OCCUPANCY LOAD (1004.0) - EXISTING RESTAURANT**

USE	AREA	SF/PERSON	OCCUPANTS
A-2	6,364 SF	15 SF/PERSON	424.26 OCCUPANTS (UNCHANGED)
MEZZANINE	529 SF	200 SF/PERSON	2.63 OCCUPANTS (UNCHANGED)
KITCHEN	2,186 SF	200 SF/PERSON	10.93 OCCUPANTS (UNCHANGED)
TOTAL BUILDING OCCUPANCY			438 OCCUPANTS (UNCHANGED)
EXIST. OUTSIDE PATIO SEATING	786 SF	15 SF/P	53 OCCUPANTS (UNCHANGED)

**PLUMBING FIXTURES (2902.1) - EXISTING**  
 REFER TO OCCUPANT LOAD TABLE FOR BASIS OF OCCUPANT LOAD.  
 NO CHANGE TO EXISTING PLUMBING FIXTURE COUNT

USE GROUP A2 491 OCCUPANTS (245.5 PER GENDER)

**MALE**

WATER CLOSETS REQUIRED 3.6  
 PROVIDED 4  
 LAVATORIES REQUIRED 2  
 PROVIDED 3

**FEMALE**

WATER CLOSETS REQUIRED 3.6  
 PROVIDED 4  
 LAVATORIES REQUIRED 2  
 PROVIDED 3  
 DRINKING FOUNTAIN REQUIRED 1  
 PROVIDED AT RESTAURANT  
 SERVICE SINKS REQUIRED 1  
 PROVIDED 1

**EGRESS WIDTH (1005.0) - EXISTING (UNCHANGED)**  
 REQUIRED: 2 INCHES X 438 OCCUPANTS = 88 INCHES TOTAL

PROVIDED:  
 DOOR 1 36 INCHES  
 DOOR 2 72 INCHES  
 TOTAL 108 INCHES PROVIDED

**EXIT ACCESS TRAVEL DISTANCE (1016.0)**  
 AUTOMATIC FIRE SUPPRESSION SYSTEM PROVIDED

ALLOWABLE LENGTH OF EXIT ACCESS TRAVEL PER USE:  
 A2 OCCUPANCY 250 FT. REQUIRED < 250 FT PROVIDED

**SPECIAL INSPECTIONS**  
 THE CONTRACTOR SHALL PROVIDE SPECIAL INSPECTIONS OF ASSEMBLIES AS REQUIRED BY CODE & FIELD INSPECTOR

NOTE: THESE DIAGRAMS ARE BASED ON THE 2009 ICC/ANSI A117.1 STANDARD FOR ACCESSIBILITY. NOT ALL CONDITIONS SHOWN MAY EXIST IN THE PROJECT. CONTRACTOR SHALL REVIEW ALL DIAGRAMS PRIOR TO LAYOUT AND VERIFY ALL CLEAR AREAS, MOUNTING HEIGHTS, AND OTHER CLEARANCES AS SHOWN ARE PROVIDED. MATERIALS, PRODUCTS AND SIZES OF FIXTURES AND EQUIPMENT SHOWN MAY NOT REFLECT THE ACTUAL PRODUCTS OR MATERIALS SPECIFIED IN THE ARCHITECTURAL DRAWINGS. REFER TO THE ACTUAL PRODUCT SPECIFIED OR PROVIDED FOR VERIFICATION.

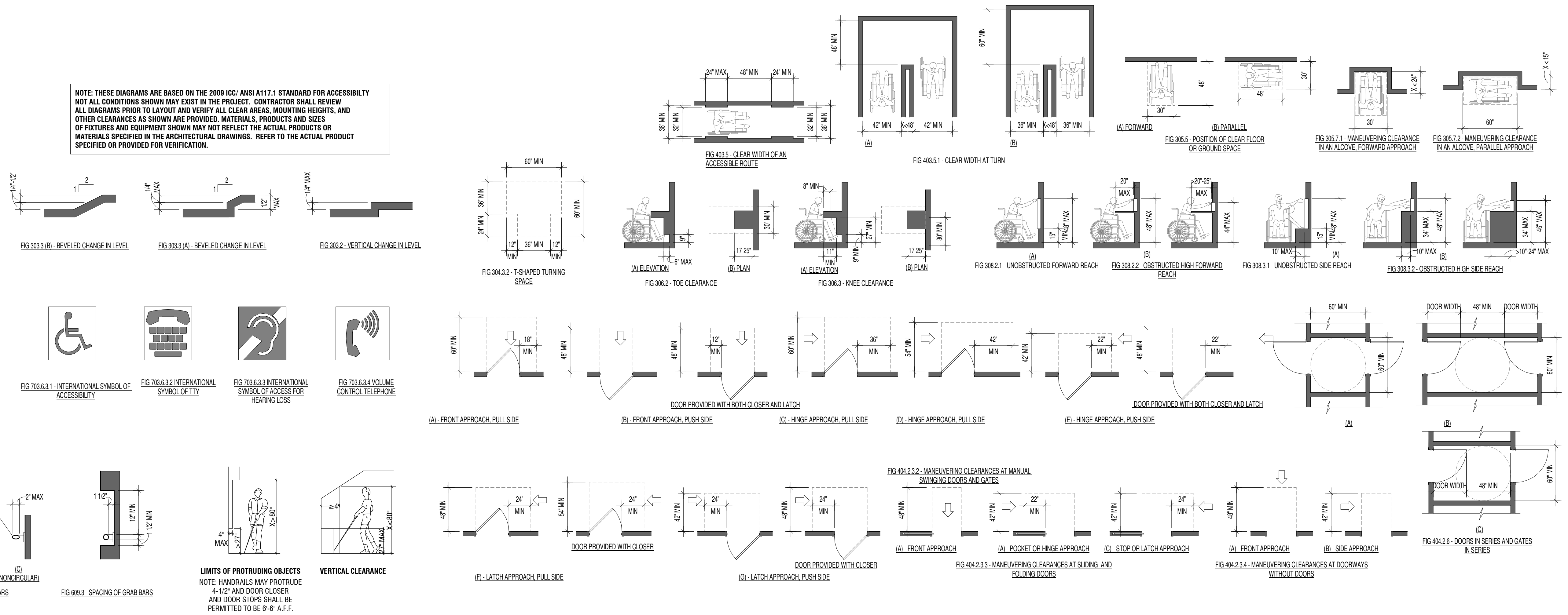

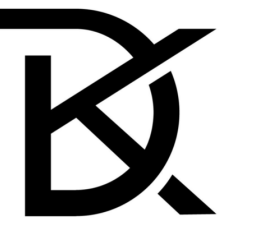

ARCHITECTS

614.503.1450  
DKARCH.US  
2960 COLUMBUS PIKE  
DELAWARE, OH 43015

PINT HOUSE - IMPROVEMENTS  
6632 LONGSHORE ST, BLDG C3  
DUBLIN, OHIO 43217

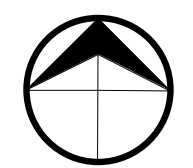
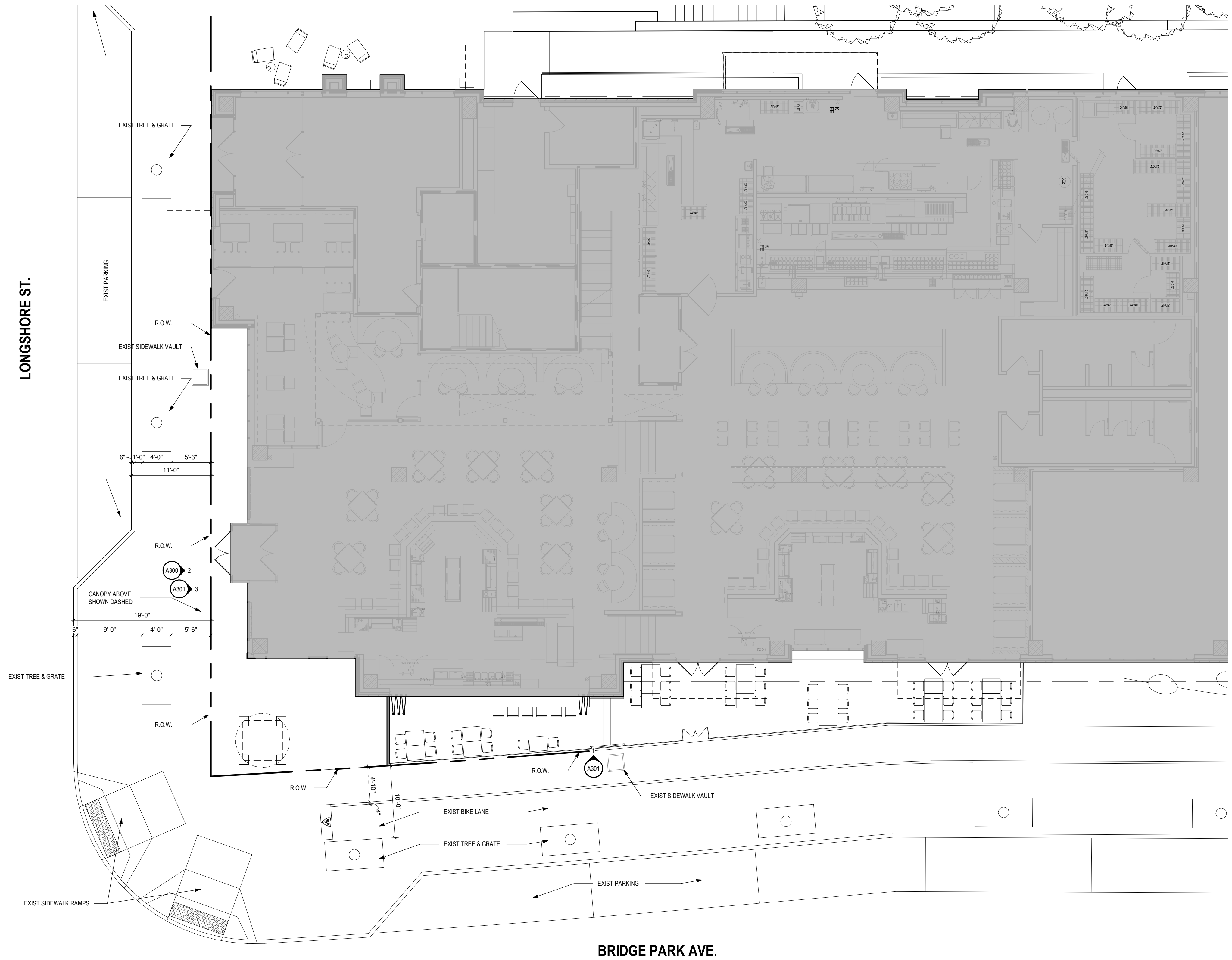

1 EXISTING SITE PLAN  
A100 1/8" = 1'-0"

Project Number: 19023  
Drawn By: PF  
Date: 5/14/2021

A100





614.503.1450  
DKARCHITECTS  
2960 COLUMBUS PIKE  
DELAWARE, OH 43015

PINT HOUSE - IMPROVEMENTS  
6632 LONGSHORE ST, BLDG C3  
DUBLIN, OHIO 43217

### DEMO PLAN GENERAL NOTES

VERIFY WITH OWNER PRIOR TO DISCARDING ANY REMOVED ITEMS.

SEE MEP DRAWINGS FOR ANY ADDITIONAL DEMOLITION, REMOVAL AND COORDINATION ITEMS.

THIS IS AN EXISTING FACILITY DEMOLITION CONTRACTOR TO FIELD VERIFY FACILITY BEFORE START OF DEMOLITION AND NOTIFY GC & ARCHITECT OF ANY DISCREPANCIES

ANY STRUCTURAL ELEMENTS NOT SHOWN ON DRAWINGS AND FOUND DURING DEMOLITION ARE TO REMAIN. NOTIFY GC & ARCHITECT OF FIND AND ONLY REMOVE UPON APPROVAL OF THE ARCHITECT.

CONTRACTORS PERFORMING DEMO WORK SHALL CLEAN OR REPAIR ANY AREAS NOT IN DEMO SCOPE AFFECTED OR DAMAGED DURING DEMO PROCESS.

ALL ADJACENT WALLS AFFECTED BY THE REMODEL SHALL BE CLEANED AND PREPPED FOR NEW FINISH

ALL AREAS AFFECTED BY DEMOLITION WORK SHALL BE CLEANED AND PREPPED FOR NEW FINISH OR WORK

### DEMO PLAN CODED NOTES

THIS SHEET ONLY

- ① EXISTING SIDEWALK PAVERS TO REMAIN
- ② REMOVE EXIST. SIDEWALK PAVERS AS REQ. & PREP FOR NEW DRINK RAIL VERTICAL POSTS. REFER TO ELEVATION FOR SPACING
- ③ REMOVE SILO INCLUDING FOUNDATIONS - COORDINATE DISPOSAL W/ OWNER. REPLACE SIDEWALK PAVERS/BRICKS AS REQUIRED; MATCH EXISTING
- ④ MODIFY EXISTING STOREFRONT SYSTEM AS REQUIRED FOR NEW DOOR - REFER TO STOREFRONT ELEVATIONS FOR MORE INFO.
- ⑤ NO WORK TO ADJACENT SIDEWALK
- ⑥ EXISTING SIDEWALK VAULT TO REMAIN-NO WORK
- ⑦ EXISTING TREE & GRATE TO REMAIN-NO WORK

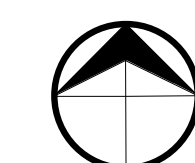
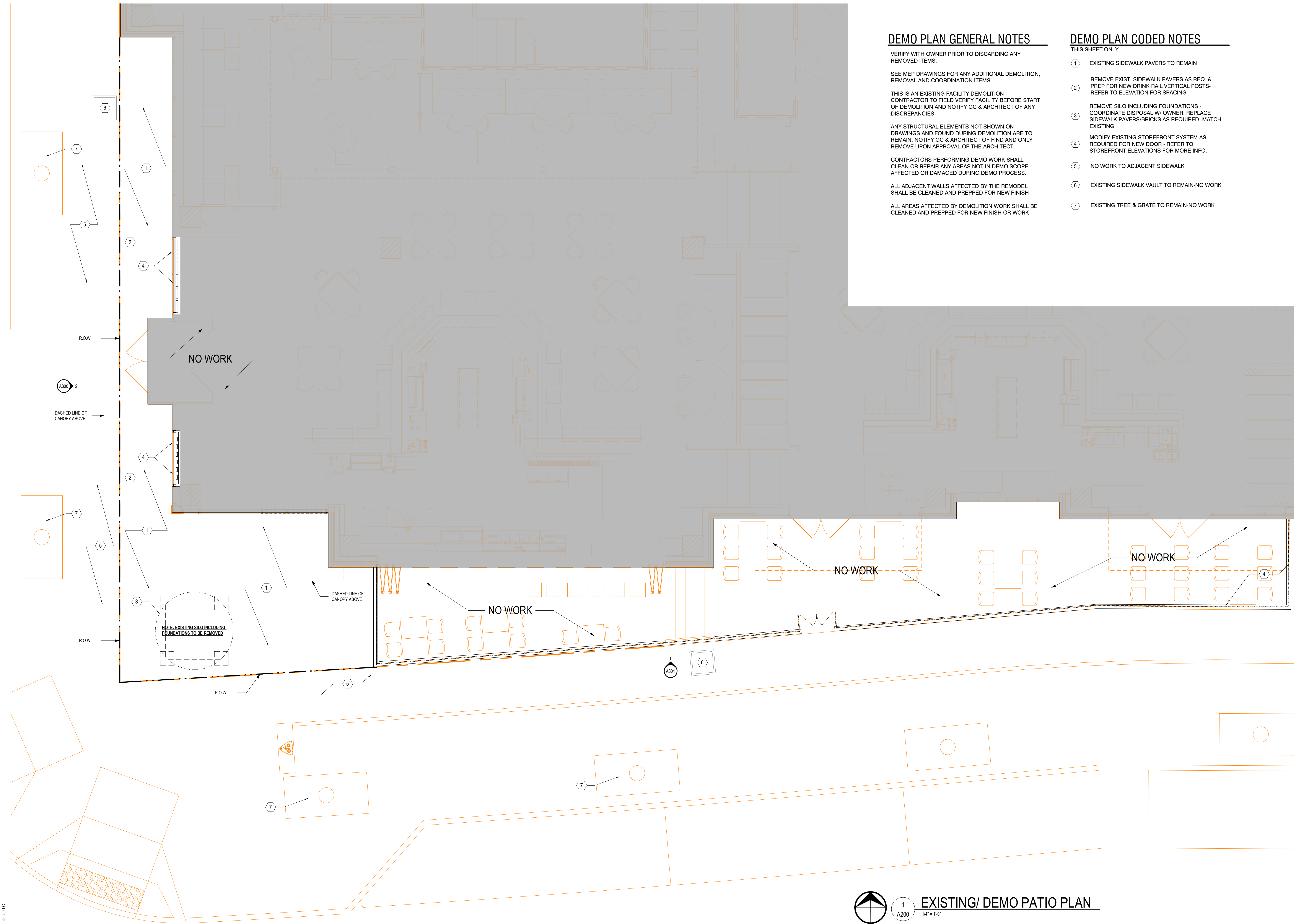

1 EXISTING/ DEMO PATIO PLAN  
A200 1/4" = 1'-0"

Project Number: 19023  
Drawn By: PF  
Date: 5/14/2021

A200





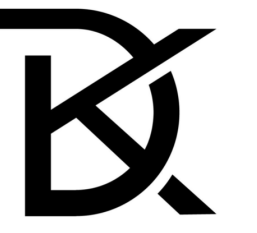

ARCHITECTS

614.503.1450  
DKARCHUS  
2960 COLUMBUS PIKE  
DELAWARE, OH 43015

**PRELIMINARY**  
NOT FOR CONSTRUCTION

**PINT HOUSE - PATIO EXPANSION**

6632 LONGSHORE ST, BLDG C3

DUBLIN, OHIO 43217

**GENERAL NOTES**

1. REFER TO MEP DRAWINGS FOR ANY ELECTRICAL OR MECHANICAL EQUIPMENT INFORMATION AND SPECIFICATIONS. ANY MEP EQUIPMENT IS SHOWN FOR GENERAL LOCATION & REFERENCE ONLY.
2. EMERGENCY, EXIT AND EGRESS LIGHTING ARE SHOWN ON ELECTRICAL DRAWINGS.
3. ALTERNATE #1--ANY SAIL AWNING ANCHOR PENETRATIONS AT THE BUILDING SHALL BE IN THE MORTAR JOINTS ONLY. VERIFY ALL SAIL AWNING ANCHOR ATTACHMENT LOADS ON THE EXISTING BUILDING AS REQ.

**RCP CODED NOTES**

- ① EXISTING CANOPY OVERHEAD SHOWN DASHED
- ② ALTERNATE #1--CANOPY ANCHOR AT FACE OF EXIST BLDG; PROVIDE IN WALL BLOCKING AS REQUIRED & VERIFY THAT CANOPY STRUCTURE IS DESIGNED TO CARRY THE NEW SAIL AWNING LOADING.
- ③ ALTERNATE #1--CANOPY ANCHOR AT GUARDRAIL COLUMN.

**SAIL AWNINGS-ALTERNATE #1**

 CANOPY: AWNING SAIL  
COLOR: BLACK

**LIGHT FIXTURES**

 PENDANT  
LOCATION: BAR

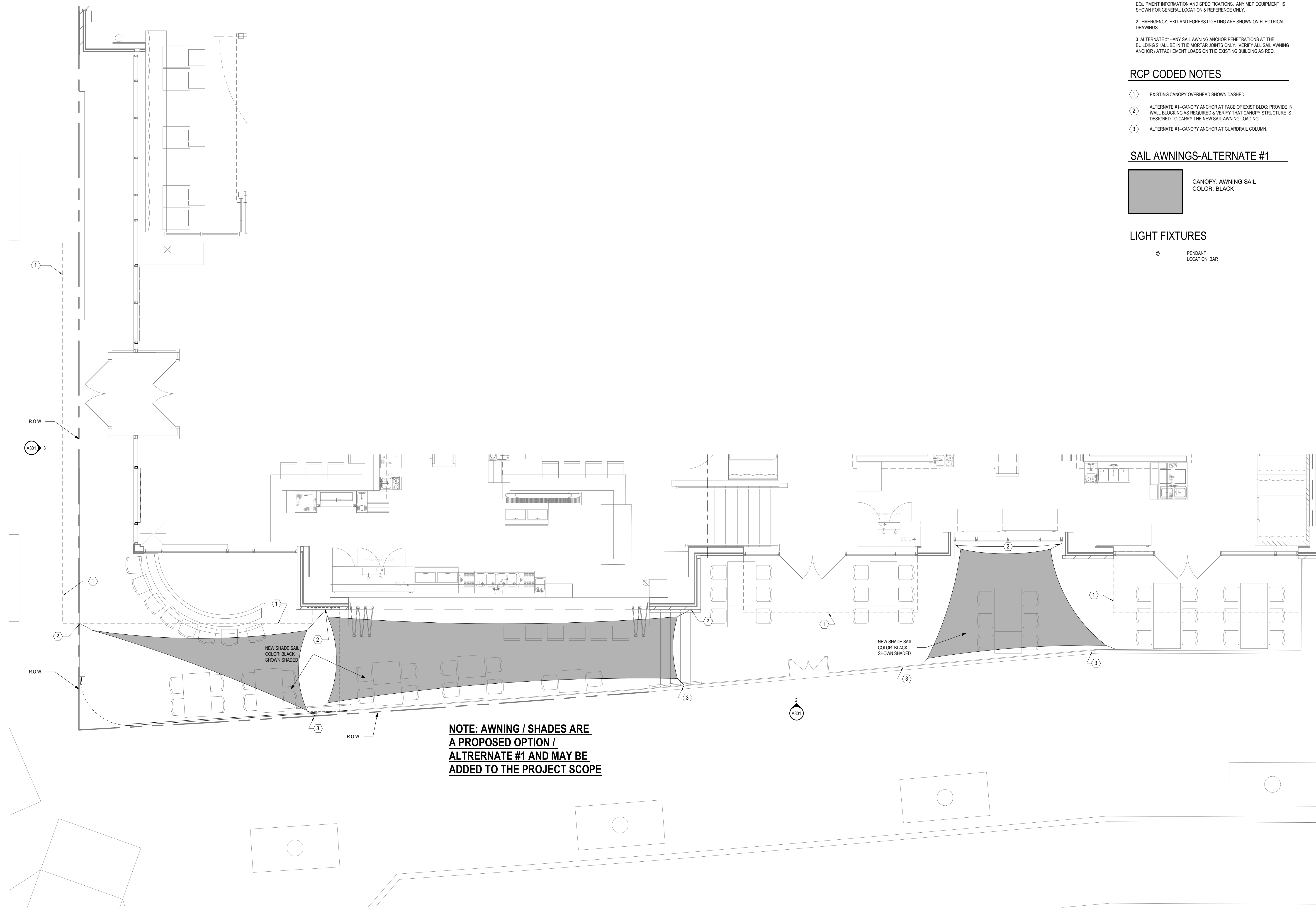

**NOTE: AWNING / SHADES ARE  
A PROPOSED OPTION /  
ALTRERNATE #1 AND MAY BE  
ADDED TO THE PROJECT SCOPE**

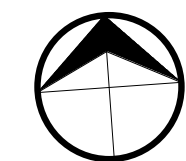

1  
A203

**REFLECTED CEILING PLAN**

1/4" = 1'-0"

Project Number: 19023  
Drawn By: PF  
Date: 03/05/2021

**A203**

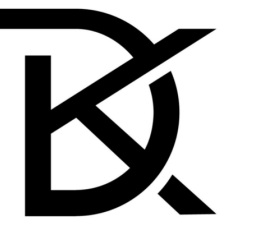

ARCHITECTS

614.503.1450  
DKARCHUS  
2960 COLUMBUS PIKE  
DELAWARE, OH 43015

PINT HOUSE - IMPROVEMENTS  
6632 LONGSHORE ST, BLDG C3  
DUBLIN, OHIO 43217

Project Number: 19023  
Drawn By: PF  
Date: 5/14/2021

A300

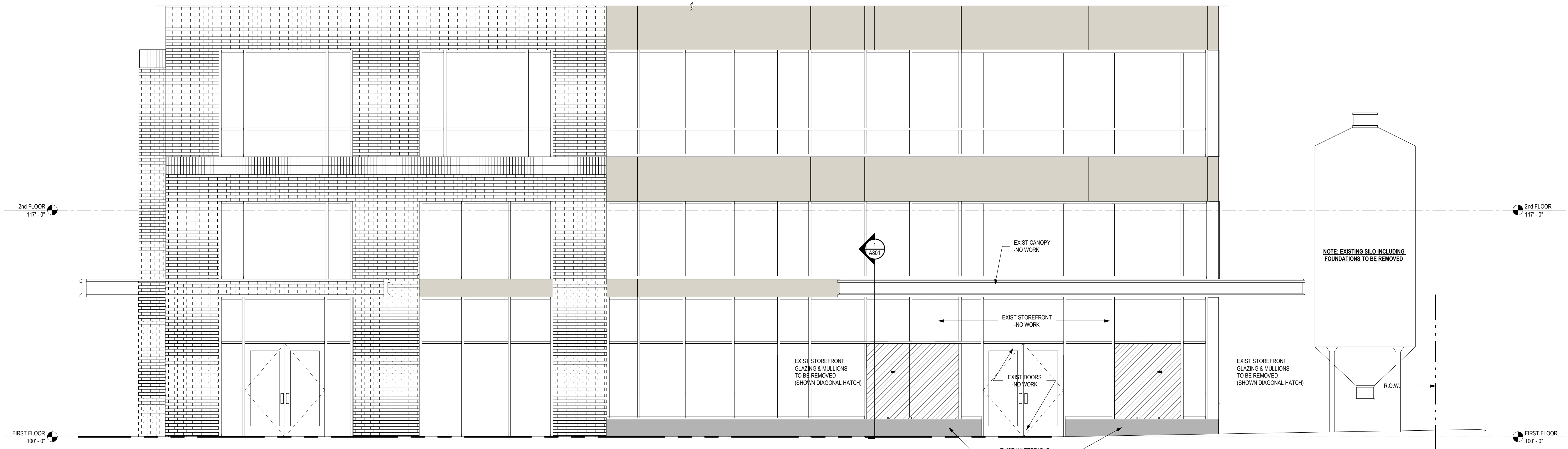

2 EXISTING WEST ELEVATION  
A300 1/4" = 1'-0"

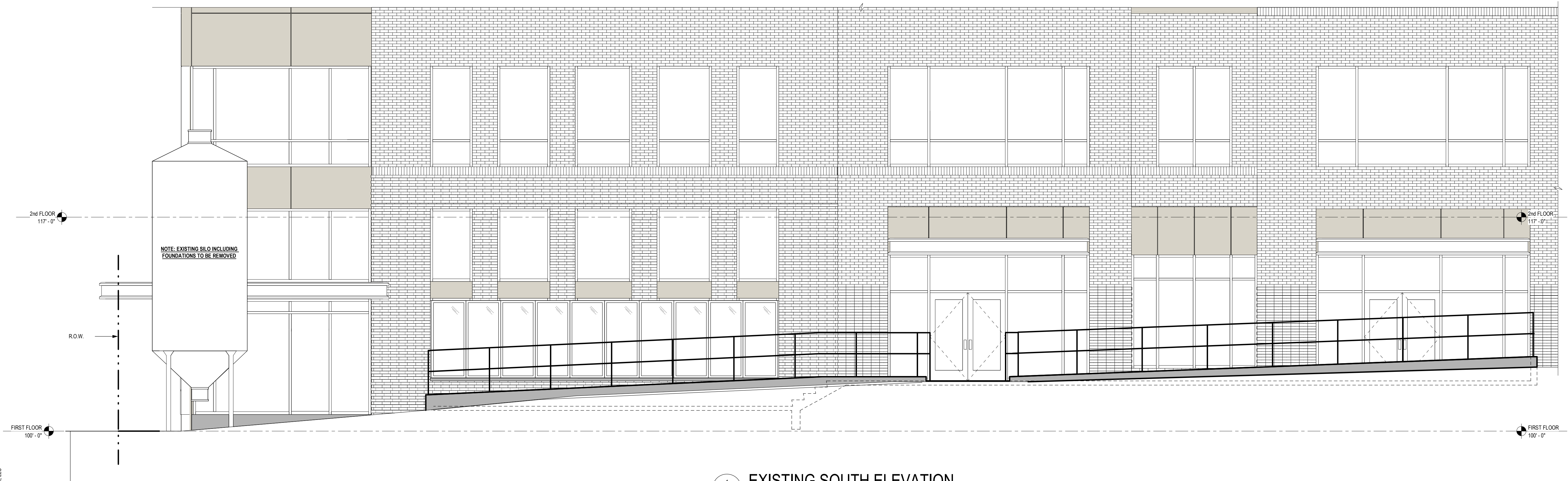

1 EXISTING SOUTH ELEVATION  
A300 1/4" = 1'-0"

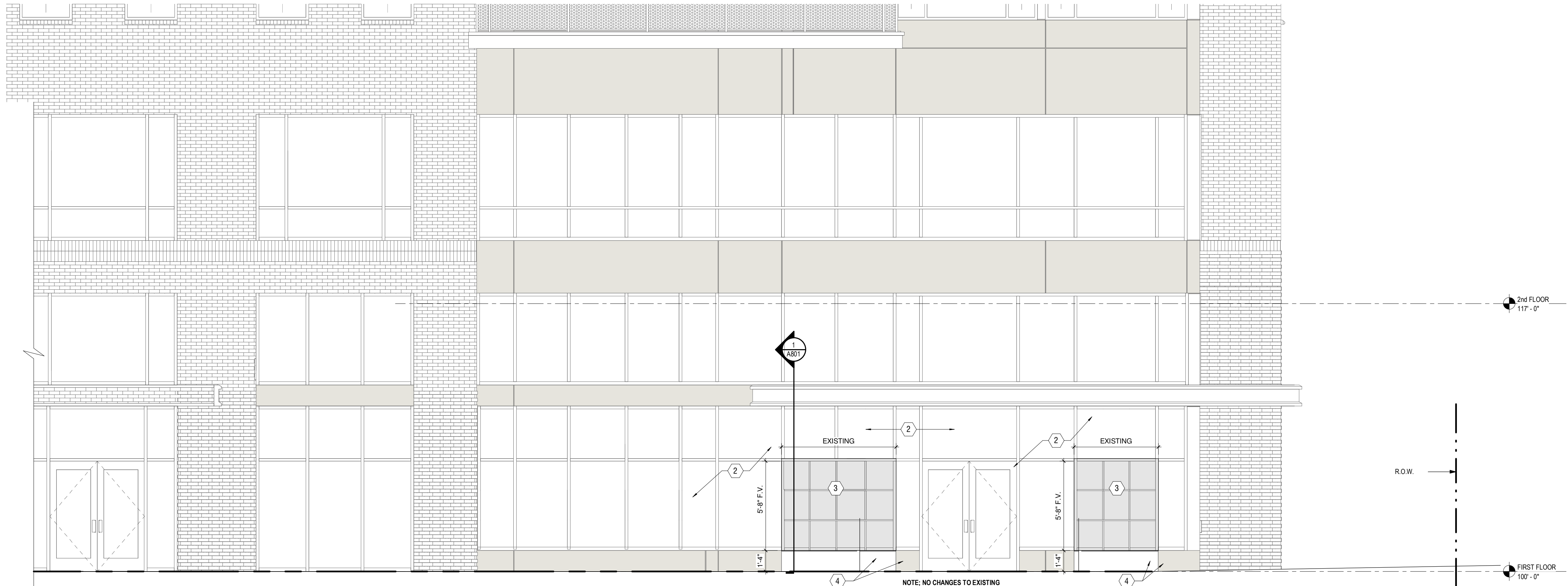

3  
A301  
WEST ELEVATION  
1/4" = 1'-0"

**ELEVATION GENERAL NOTES**

- SCOPE OF WORK TO EXISTING BUILDING EXTERIOR ELEVATIONS IS LIMITED - FULL SCOPE OF WORK TO EXISTING EXTERIOR ELEVATIONS IS INDICATED ON THIS SHEET
- ALL EXTERIOR BLDG SIGNAGE TO REMAIN - NO WORK

**ELEVATION CODED NOTES**

- THIS SHEET ONLY
- ① "NOT USED"
  - ② EXISTING STOREFRONT SYSTEM TO REMAIN-NO WORK
  - ③ PROVIDE NEW OVERHEAD DOOR IN EXISTING STOREFRONT SYSTEM (SHOWN SHADED)-REFER TO PLAN, ELEVATION & DOOR SCHEDULE FOR MORE INFO.
  - ④ EXISTING STONE KNEEWALL/WATERTABLE TO REMAIN-NO WORK

**DK ARCHITECTS**  
614.503.1450  
DKARCH.US  
2960 COLUMBUS PIKE  
DELAWARE, OH 43015

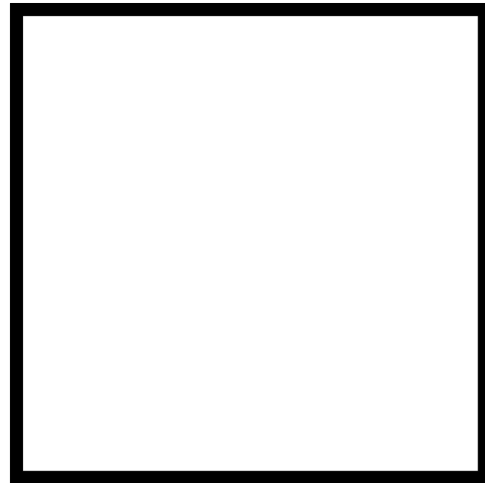

**PINT HOUSE - IMPROVEMENTS**  
6632 LONGSHORE ST, BLDG C3  
DUBLIN, OHIO 43217

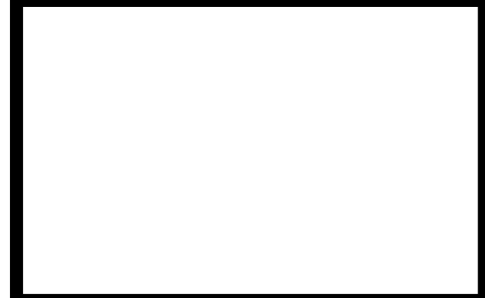

1  
A301  
NEW SOUTH ELEVATION  
1/4" = 1'-0"

Project Number: 19023  
Drawn By: PF  
Date: 5/14/2021

**A301**





614.503.1450  
 DKARCH.US  
 2960 COLUMBUS PIKE  
 DELAWARE, OH 43015

**PRELIMINARY**  
 NOT FOR CONSTRUCTION

**PINT HOUSE - PATIO EXPANSION**

6632 LONGSHORE ST, BLDG C3

DUBLIN, OHIO 43217

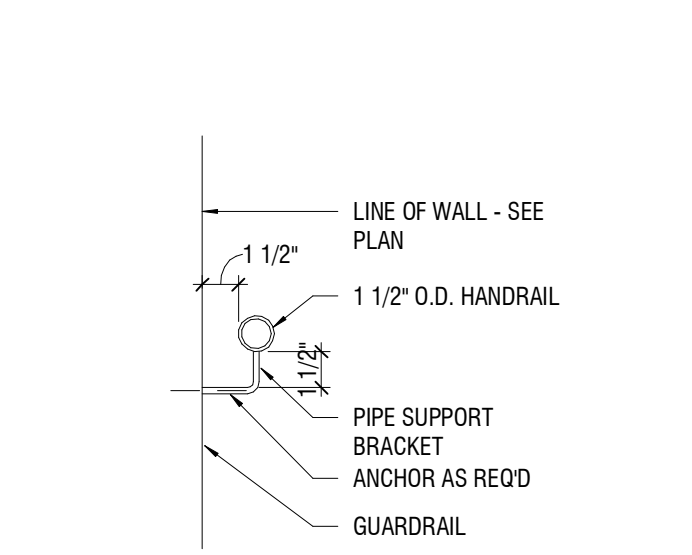

**BB HANDRAIL DETAIL**  
 A401 1 1/2" = 1'-0"

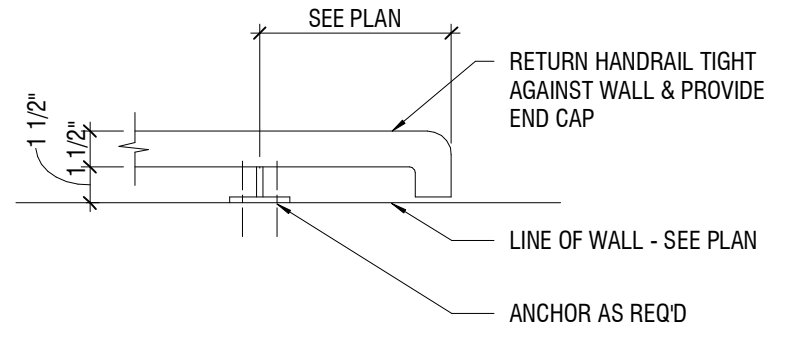

**AA HANDRAIL WALL RETURN**  
 A401 1 1/2" = 1'-0"

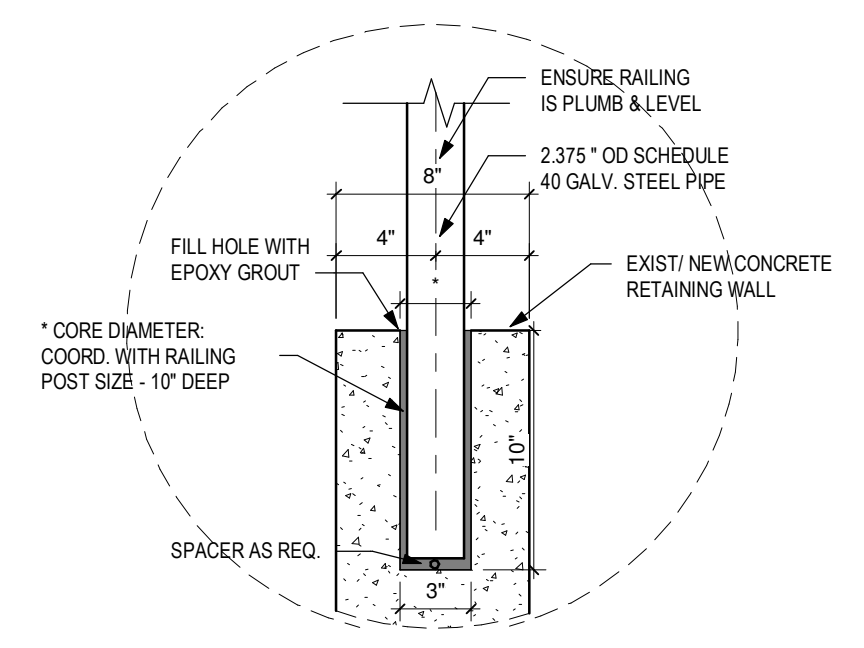

**E Railing Core Drill**  
 A401 1 1/2" = 1'-0"

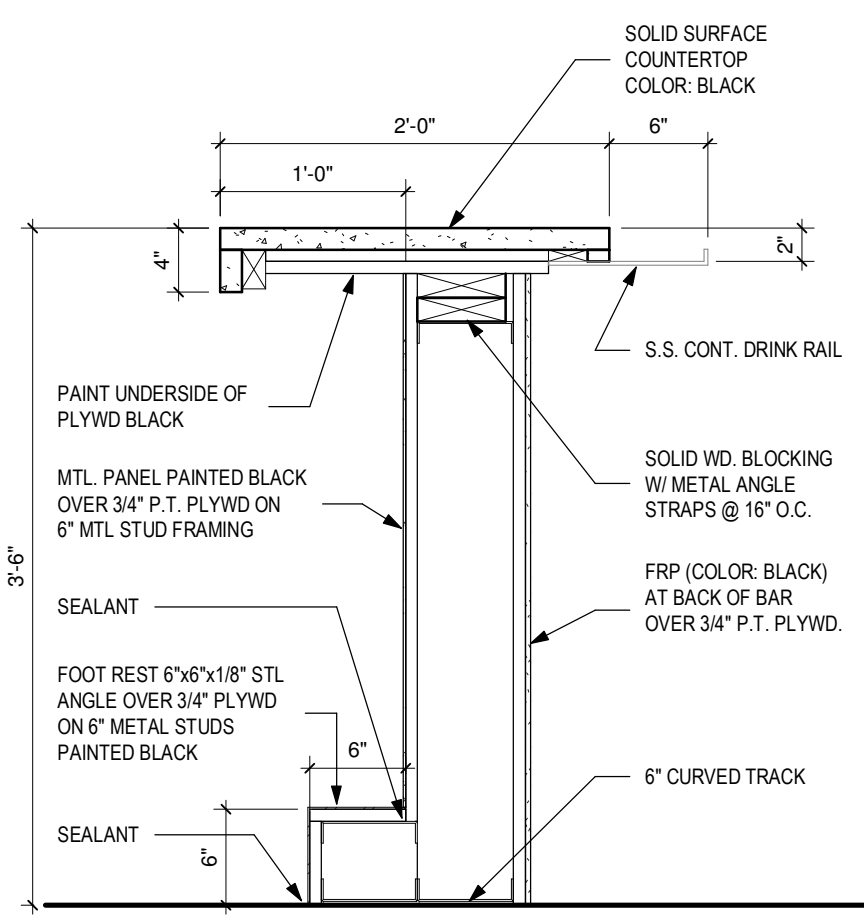

**D Bar Section**  
 A401 1" = 1'-0"

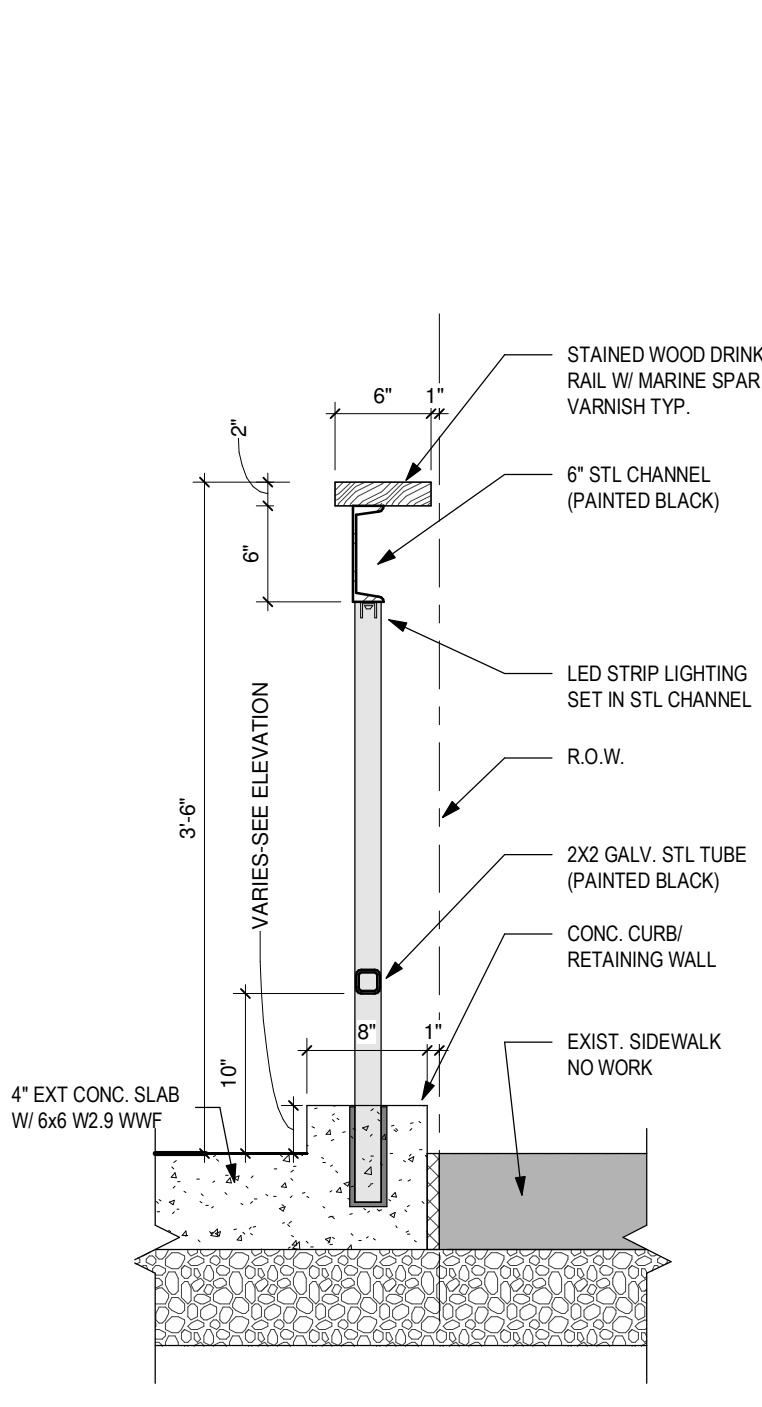

**C DRINK RAILING**  
 A401 1" = 1'-0"

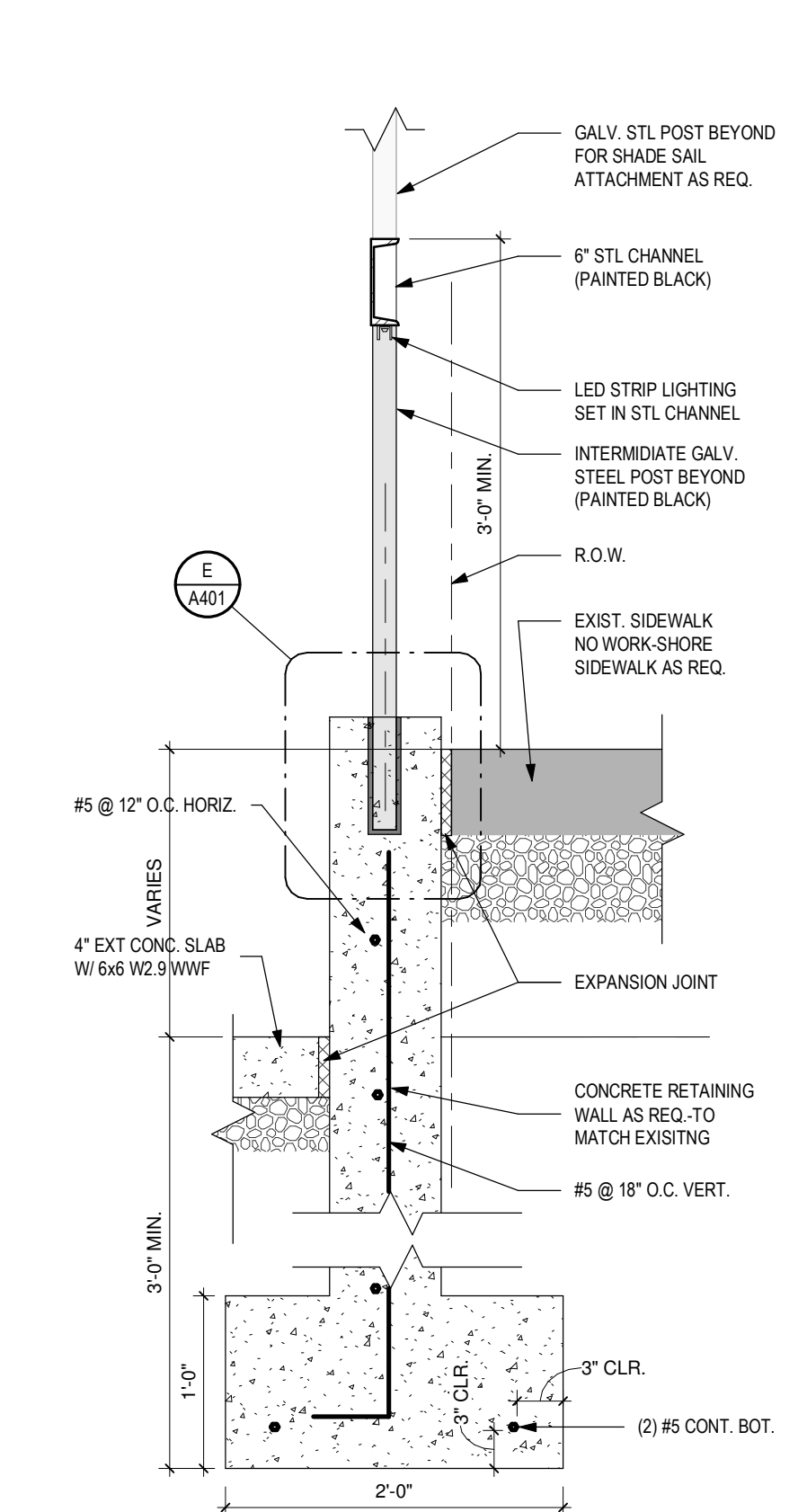

**B TYP RAILING**  
 A401 1" = 1'-0"

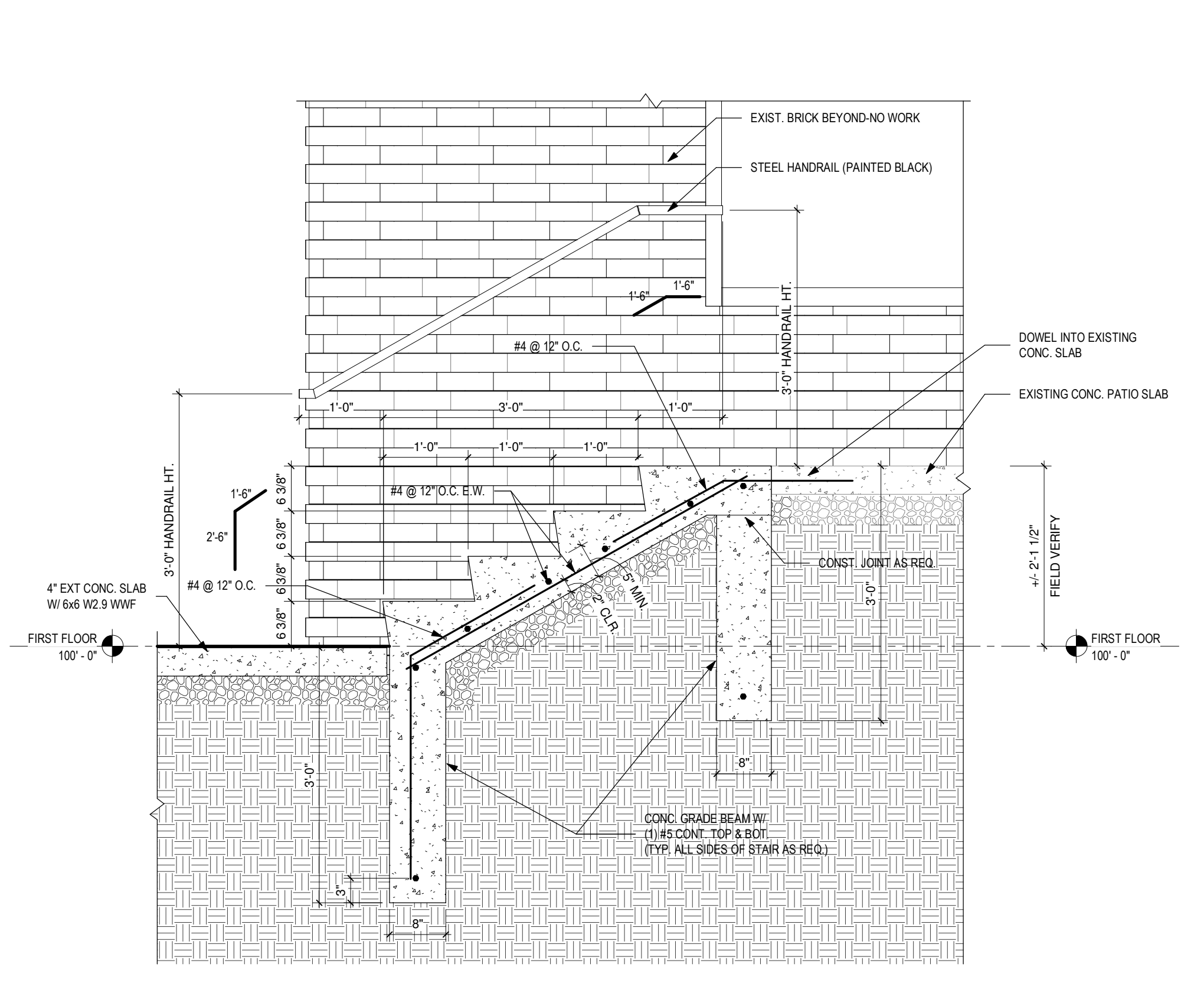

**A STAIR SECTION**  
 A401 3/4" = 1'-0"

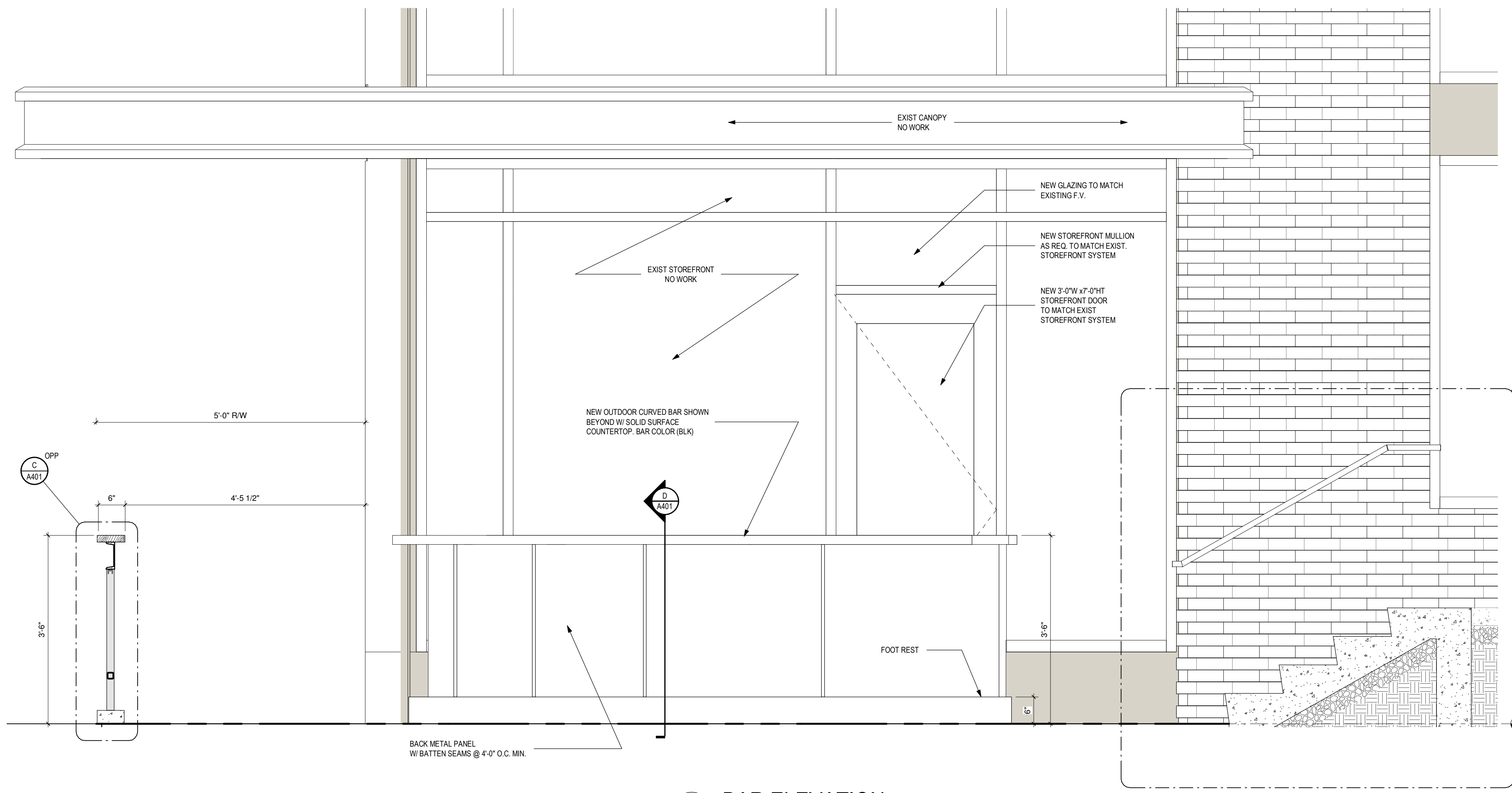

**2 BAR ELEVATION**  
 A401 3/4" = 1'-0"

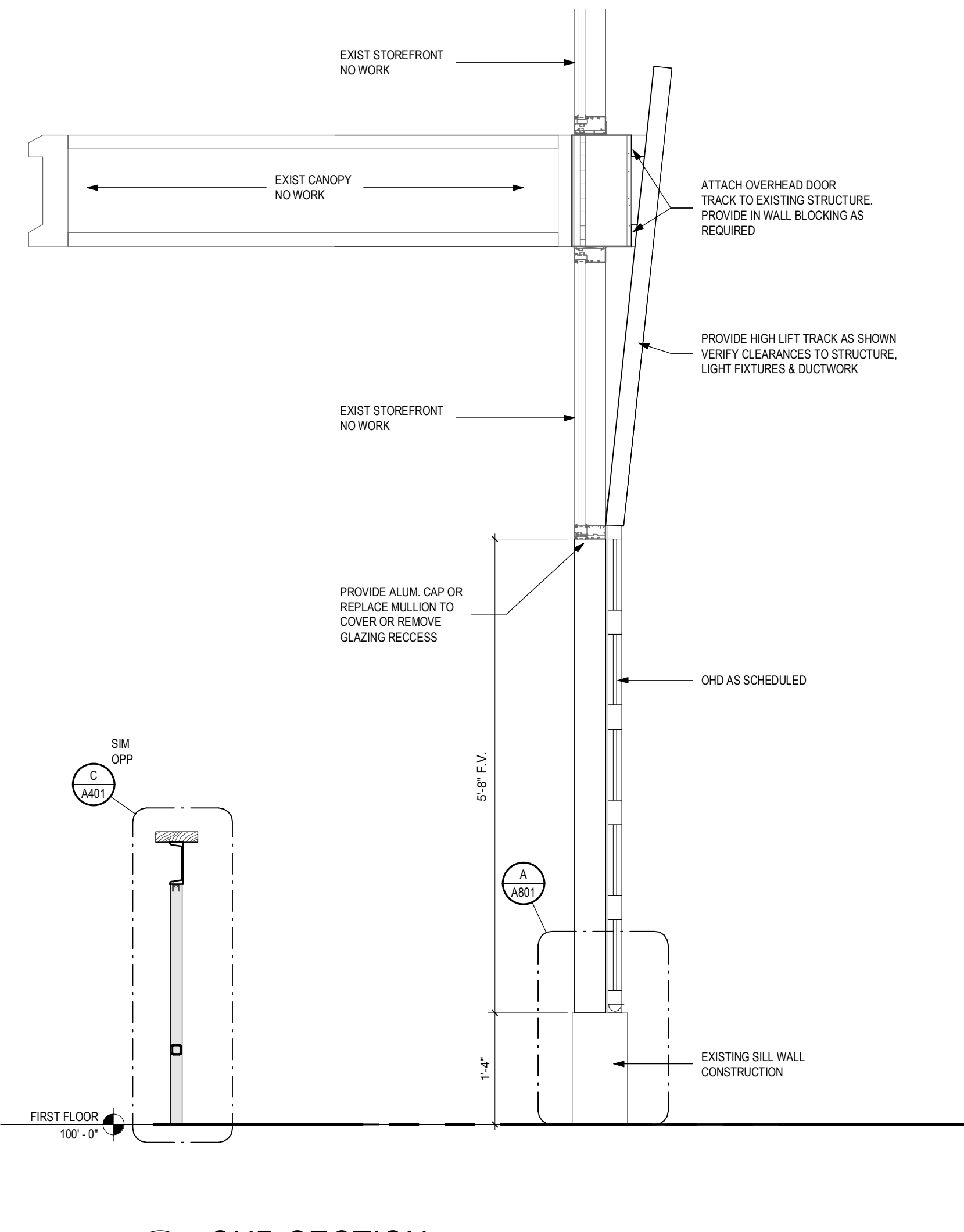

**1 OHD SECTION**  
 A401 3/4" = 1'-0"

