



DIVISION OF BUILDING STANDARDS

RESIDENTIAL DECK PERMIT INFORMATION

Building permits are required for all attached decks, regardless of size, and unattached decks over 200 SF

Electrical and gas permits may also be required depending on the nature of the work which is being completed.

All work is to be performed in conjunction with the provisions of the 2019 Residential Code of Ohio, as amended and the city of Dublin Zoning Code.

When contractors are being hired to complete the work, please contact the City regarding Contractor Registration. If you, as the homeowner, are performing the work, a Homeowner's Affidavit must be completed.

Submittal

The applicant will submit the following electronically:

- Permit Application
- Site plan
- Complete set of drawings (see [Deck Package](#) for details)
- Current City of Dublin Contractor Registration or Homeowner's Affidavit*

**Homeowner Affidavit is required if a City of Dublin registered contractor is not performing all of the work*

Electronic Plan Submittal

Electronic Plan Submittal is required. ePlan is the City of Dublin's Electronic Plan Review system. It is a web-based solution that allows documents and drawings to be submitted electronically, replacing the traditional paper-based plan review method. ePlan improves the plan review cycle, reduces costs associated with obtaining permit approvals and supports the City of Dublin's green initiatives. Please call (614) 410-4608 to become an ePlan user and for more information on how to use ePlan.

Site Plan (see attached)

See Deck Package for details

A site plan is a drawing or a survey that shows the property lines of a tract of property and all structures built upon it. The information must be drawn to scale. Copied Site Plans may change the scale of the drawing, thus these processes should be avoided.

The following items must be shown on the site plan:

- All existing structures on a lot and distances to property lines
- The exact location of the proposed deck and steps
- The exact dimensions of the proposed deck and steps
- The distance from the deck and steps to the property lines and to any easement, no build zone or no disturb zone within 3 feet of deck or steps

All distances from deck and/or steps must be measured at right angles to the property or easement lines

Construction Drawing Requirements

See [Deck Package](#) for details

The following items must be shown on construction drawings (drawings must be to scale and show all dimensions)

- Foundation/footing plan with post foundation layout, footing sizes, post sizes, and dimensions
- Floor framing plan with grade of wood, framing member sizes, and spacing
- Connections of all structural members
- Guardrail, handrail and stair detail





DIVISION OF BUILDING STANDARDS

RESIDENTIAL DECK PERMIT INFORMATION

Accurate and complete information provided in accordance with the attached documentation will expedite a thorough review of the project

For a pre-submittal meeting with the plans examiner, call 614-410-4613

Plan Review

- Engineering will review the site plan. Please direct any questions to Engineering at (614) 410-4614
- Zoning will review the site plan. Please direct any Zoning questions to (614) 410-4600
- The Residential Plans Examiner will review the construction drawings for compliance with the 2019 Residential Code of Ohio, as amended. Please direct Building questions to (614) 410-4613

Disapprovals

If a submittal is disapproved, the applicant will be notified by telephone and will receive a Unified Response Letter, which includes comments from the reviewers. The applicant must pick up the disapproved submittal, make revisions and resubmit the project. Include the previously disapproved set in addition to the revised set.

Plan Approval and Permit Issuance

The applicant is notified when all approvals are granted. **After the fees are paid and the permit is picked up, construction may begin.**





DIVISION OF BUILDING STANDARDS

RESIDENTIAL DECK PERMIT INFORMATION

Inspections

Approved plans, sign-off card and paperwork must be on site for all inspections. Separate permits are required for electric, gas piping, and plumbing.

All inspections except plumbing are scheduled by calling the automated inspection line at 410-4680 prior to 6:00 a.m. of the business day of the inspection. The following inspections may be required:

- Footing Inspection – this inspection should be requested after the post holes are dug and/or footing forms are set and **before** the concrete is poured
- Framing Inspection – This inspection should be requested prior to installing decking materials
- Final Inspection – This inspection should be requested once the deck is completed

To Schedule an inspection:

Please access the citizen access portal, <https://aca-prod.accela.com/dublinoh/default.aspx>, to schedule an inspection. If the request is made before 6:00 a.m., the inspection will be conducted that same business day. Please have the following information at hand when the request is placed: type of inspection, address where the inspection is to be conducted and permit number. Building inspectors will not enter a home when the owner or the owner's representative is not in attendance. If a representative is only available at certain hours, please state this information along with a phone number so that the inspectors may call to confirm, if necessary. Inspections are generally conducted from 8:30 a.m. to 4:00 p.m., Monday through Friday (except Thursday, when inspections will be from 9:45 a.m. to 4:00 p.m.). The building inspectors are available from 7:30-8:00 a.m. and 3:30-4:30 p.m. daily to answer questions, by phoning 614-410-4670.

IF YOU HAVE FURTHER QUESTIONS ABOUT THESE PROCEDURES, PLEASE FEEL FREE TO CONTACT BUILDING STANDARDS AT (614) 410-4670 FROM 8:00 A.M. – 4:00 P.M. MONDAY, TUESDAY, WEDNESDAY AND FRIDAY AND 9:30 A.M. – 4:00 P.M. THURSDAY.



PLEASE TAKE NOTE:

IF YOU HAVE BEEN ISSUED ANY OF THE FOLLOWING PERMITS, YOU MAY REQUIRE SEPARATE ELECTRIC, HEATING & VENTILATION AND PLUMBING PERMITS.

REMODEL BASEMENT FINISH

DECK

SCREENED PORCH

SWIMMING POOL





DIVISION OF BUILDING STANDARDS

HOMEOWNER AFFIDAVIT

5800 Shier-Rings Road Dublin, Ohio 43016

Phone: (614) 410-4670

Inspection Line: (614) 410-4680

Homeowner: _____ **Phone Number:** _____

Address: _____

By signing this affidavit, I do hereby swear and/or affirm that I am the Owner and occupant of the single-family dwelling located at the above address. I am making application for a Permit. If granted, **I WILL PERSONALLY PERFORM THE WORK ASSOCIATED WITH THIS PROJECT, OR CONTRACT ONLY WITH A CONTRACTOR REGISTERED WITH THE CITY OF DUBLIN.** I understand I am personally responsible to assure all work performed under the permit is compliant with all related building codes and ordinances of the City of Dublin. As prescribed by Chapter 150.140-150.146 of the Codified Ordinances of the City of Dublin,

I UNDERSTAND VIOLATION OF THE TERMS OF THIS AFFIDAVIT ARE A BASIS FOR REVOKING THE PERMIT, AND PROSECUTION OF ANY PARTY INVOLVED.

Sworn to and subscribed before me this _____ day of _____, 20____

Homeowner: _____ **Notary:** _____



DECK SITE PLAN

NOTE: IF DECK OR SCREENED PORCH IS WITHIN 3'± OF AN EASEMENT, DIMENSION TO EASEMENT MUST BE SHOWN.

SHOW DIMENSIONS OF DECK OR SCREENED PORCH AND STEPS.

ALL DIMENSIONS FROM DECK OR SCREENED PORCH TO PROPERTY LINES MUST BE AT 90°. (CLOSEST DIMENSION TO PROPERTY LINE)

APPROVED PLANS MUST BE ON SITE FOR ALL INSPECTIONS.

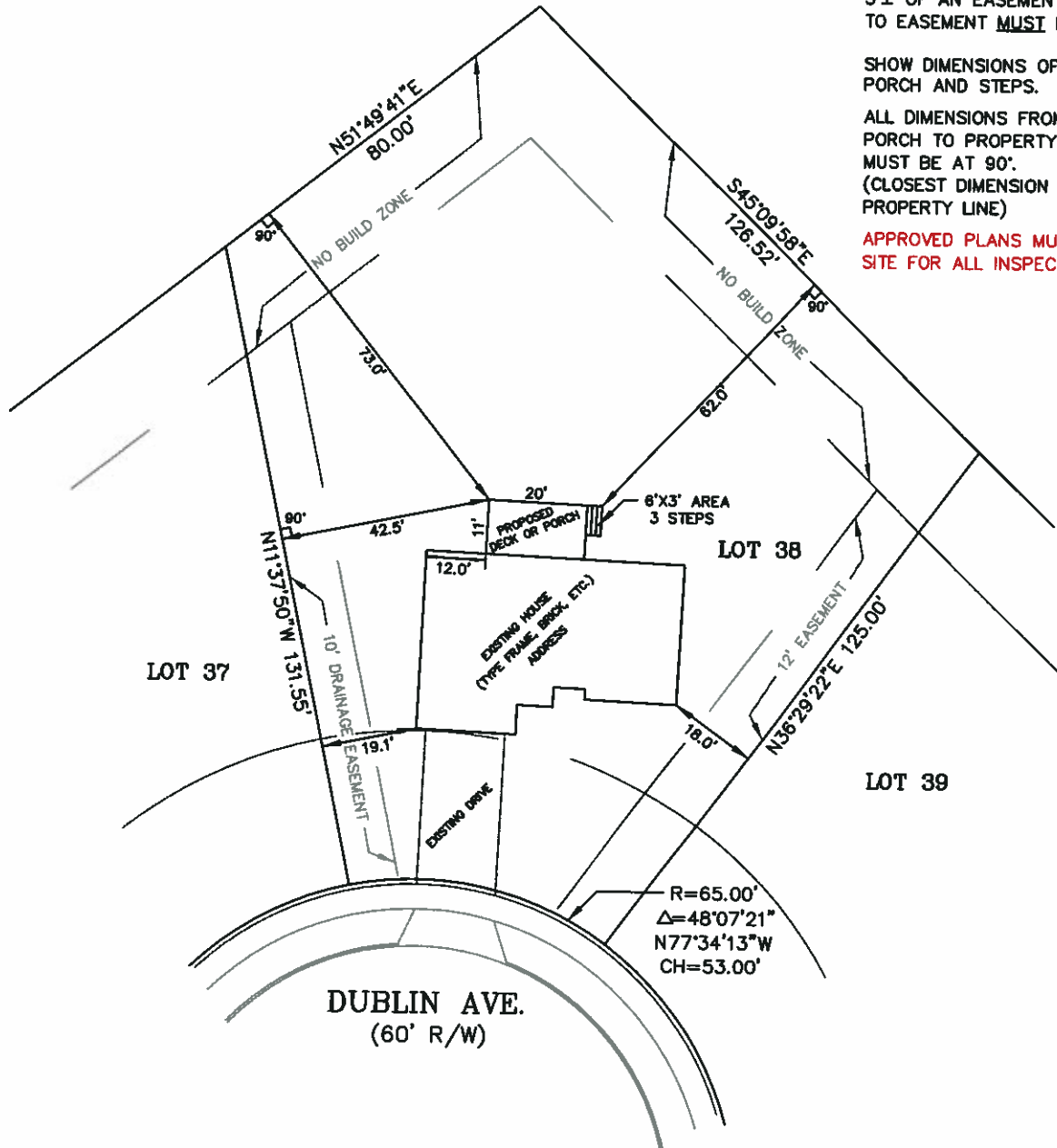

FLOOR PLAN

(SAMPLE ONLY)

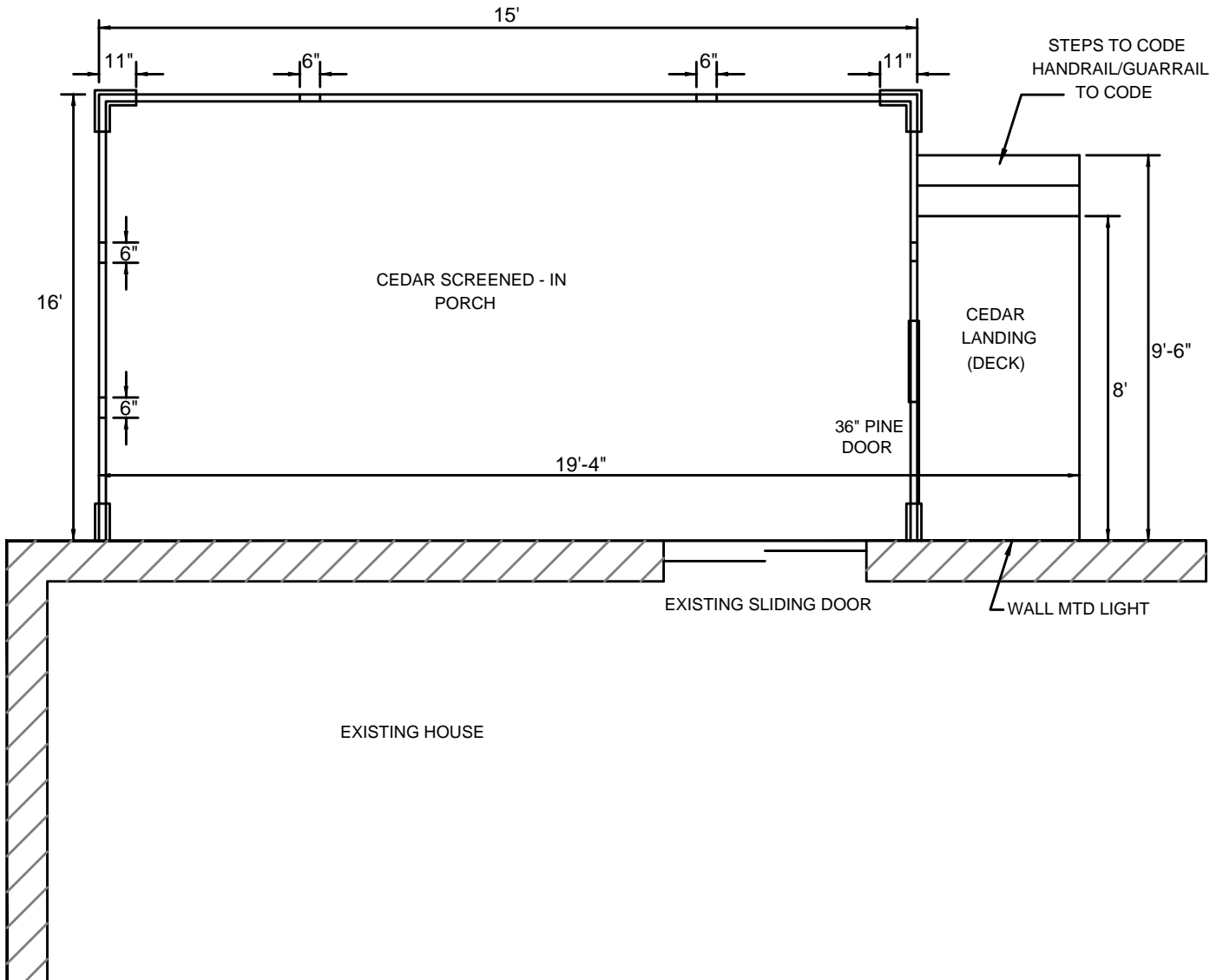



NOTES:

HANDRAIL WITH CIRCULAR 1 1/4" MIN. ~ 2 5/8" MAX. DIAMETER OR PROVIDE EQUIVALENT GRASPABILITY.

HANDRAIL AND GUARDRAILS TO MEET SECTION 315-OHIO RESIDENTIAL CODE 4" MAXIMUM SPACE.

7 3/4" MAX. RISE 10" MIN. RUN PER CITY OF DUBLIN.

UNDERGROUND UTILITIES	
	Two Working Days BEFORE YOU DIG
	
Call 800-362-2764 (Toll free)	
OHIO UTILITIES PROTECTION SERVICE	
NON-MEMBERS MUST BE CALLED DIRECTLY	

FLOOR FRAMING PLAN

(SAMPLE ONLY)

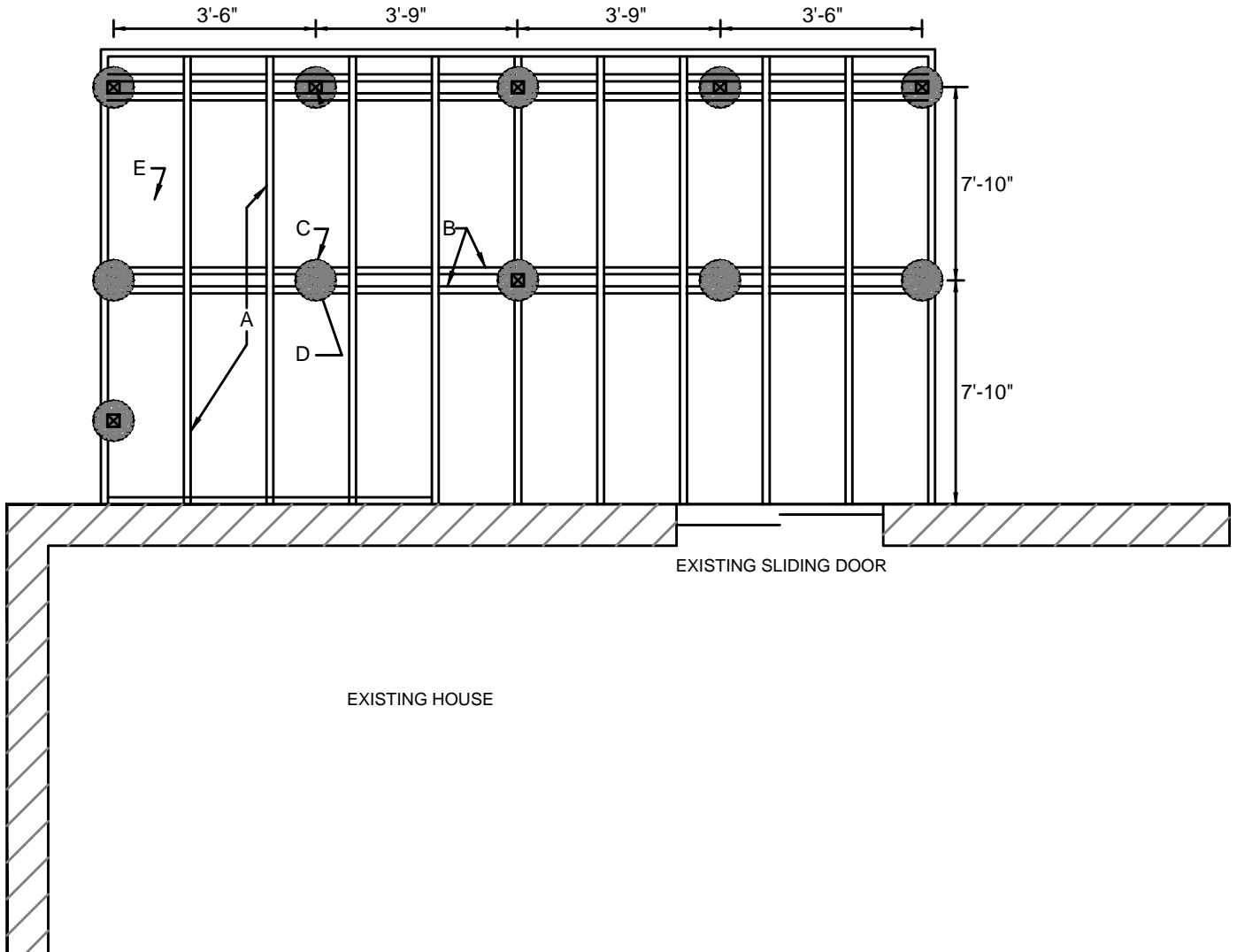

LEGEND

- A = FLOOR JOIST
- B = BEAM W/ 1/2" CARIAGE BOLTS
- C = FOOTING, MIN. 36" BELOW GRADE.
- D = 4X4 PT POST
- E = GRAVEL OVER 6 MIL VISQUEEN.

UNDERGROUND UTILITIES	
	Two Working Days BEFORE YOU DIG
	Call 800-362-2764 (Toll free)
OHIO UTILITIES PROTECTION SERVICE	
NON-MEMBERS MUST BE CALLED DIRECTLY	

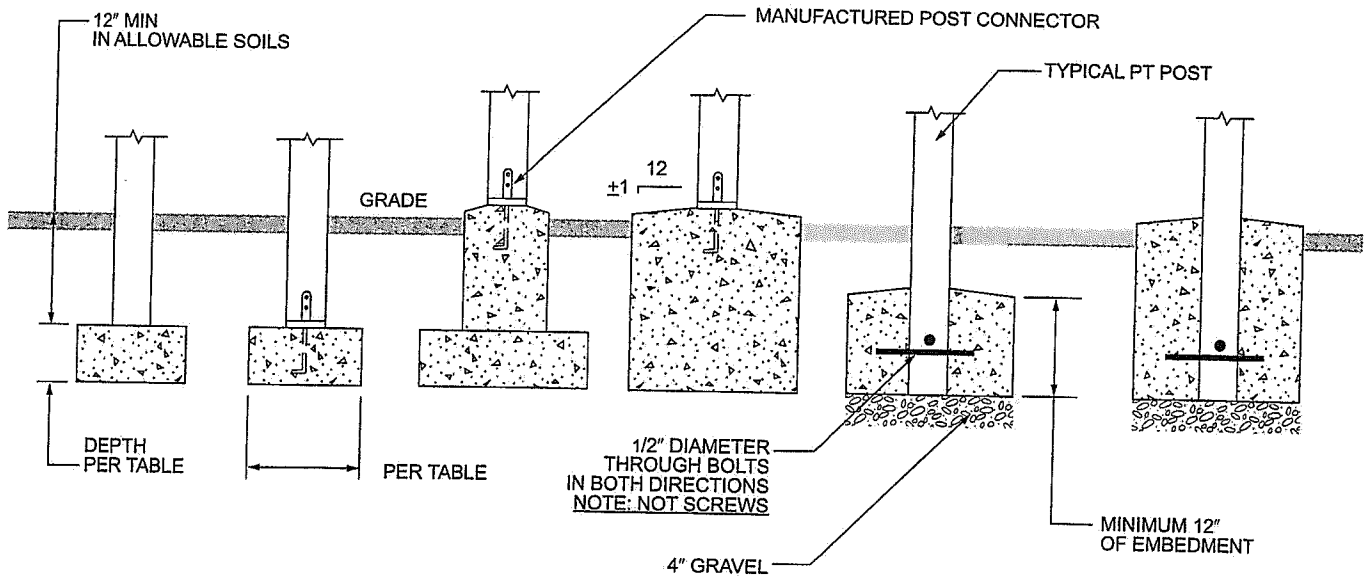

NOTE:
POSTS MUST BE CENTERED ON OR IN FOOTING

For SI: 1 inch = 25.4 mm.

DECK POSTS TO DECK FOOTING CONNECTION

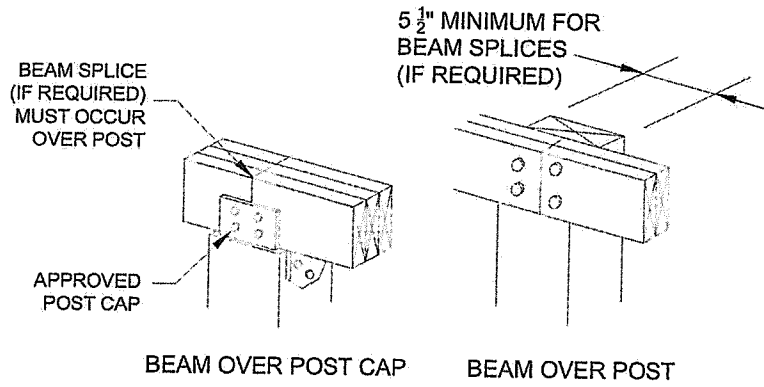

For SI: 1 inch = 25.4 mm.

DECK BEAM TO DECK POST

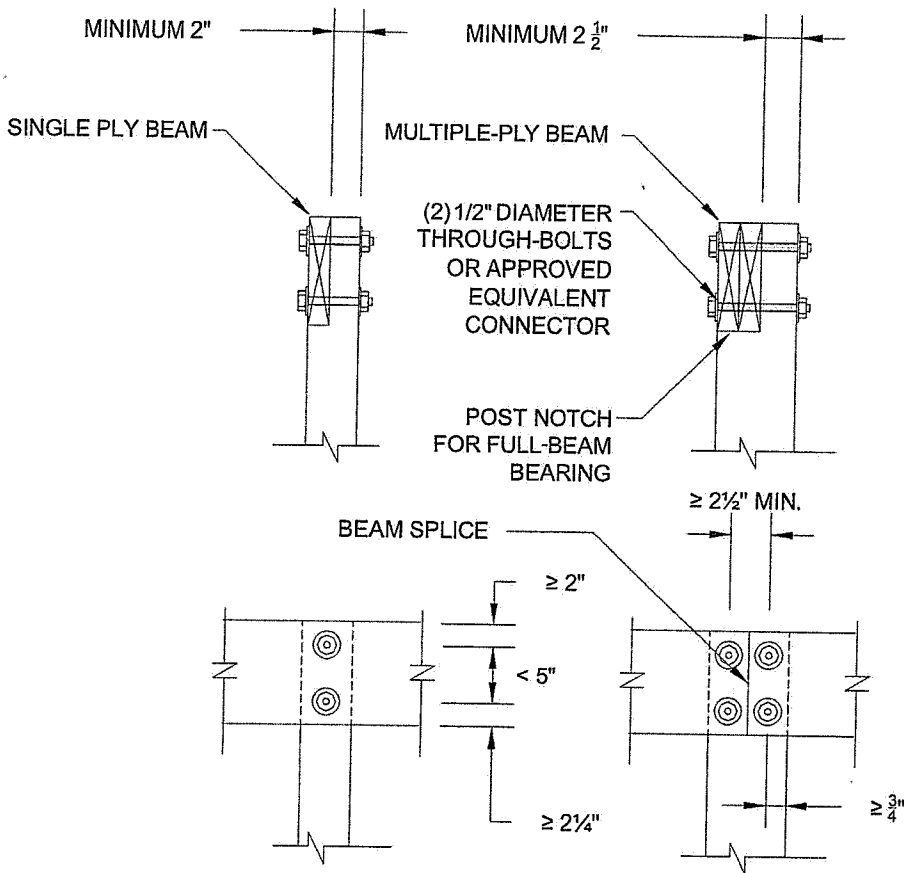

For SI: 1 inch = 25.4 mm.

NOTCHED POST-TO-BEAM CONNECTION

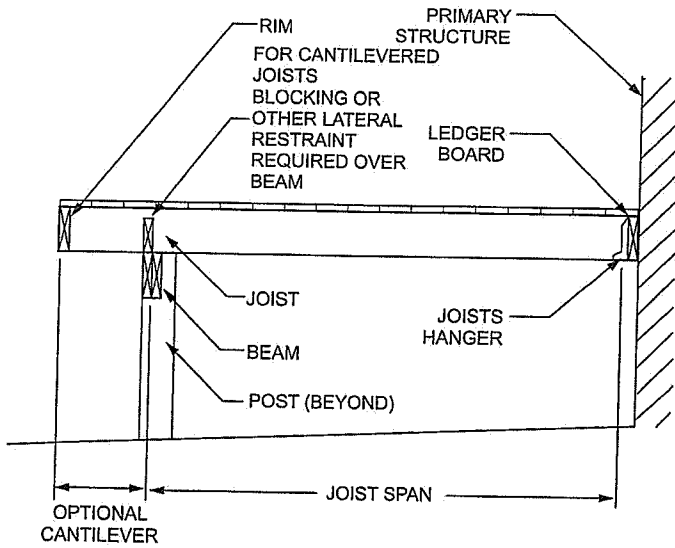

CANTILEVERED JOISTS WITH DROPPED BEAM

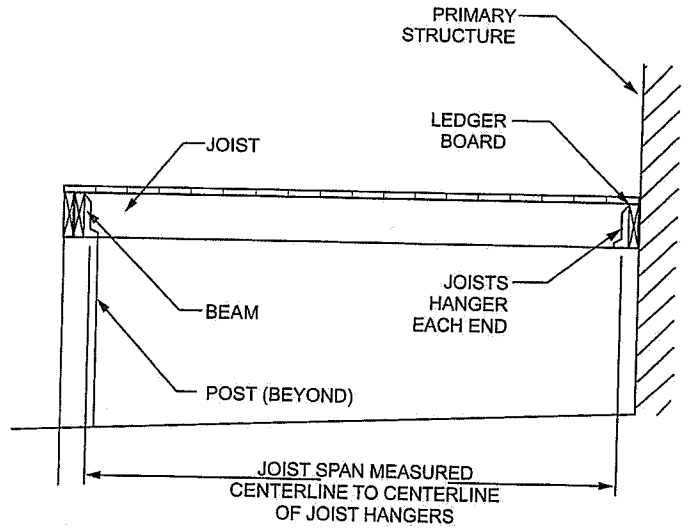

JOISTS WITH FLUSH BEAM

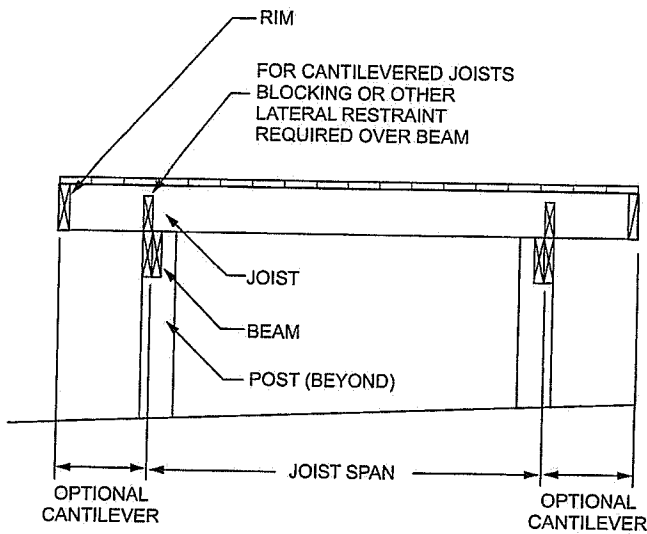

JOISTS ON FREE-STANDING DECK
WITH DROPPED BEAM

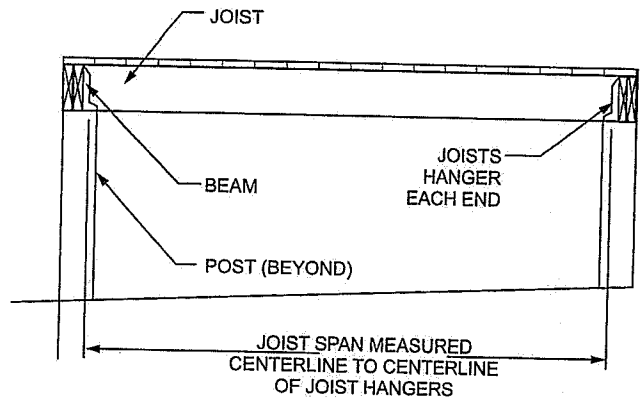

JOISTS ON FREE-STANDING DECK
WITH FLUSH BEAM

TYPICAL DECK JOIST SPANS

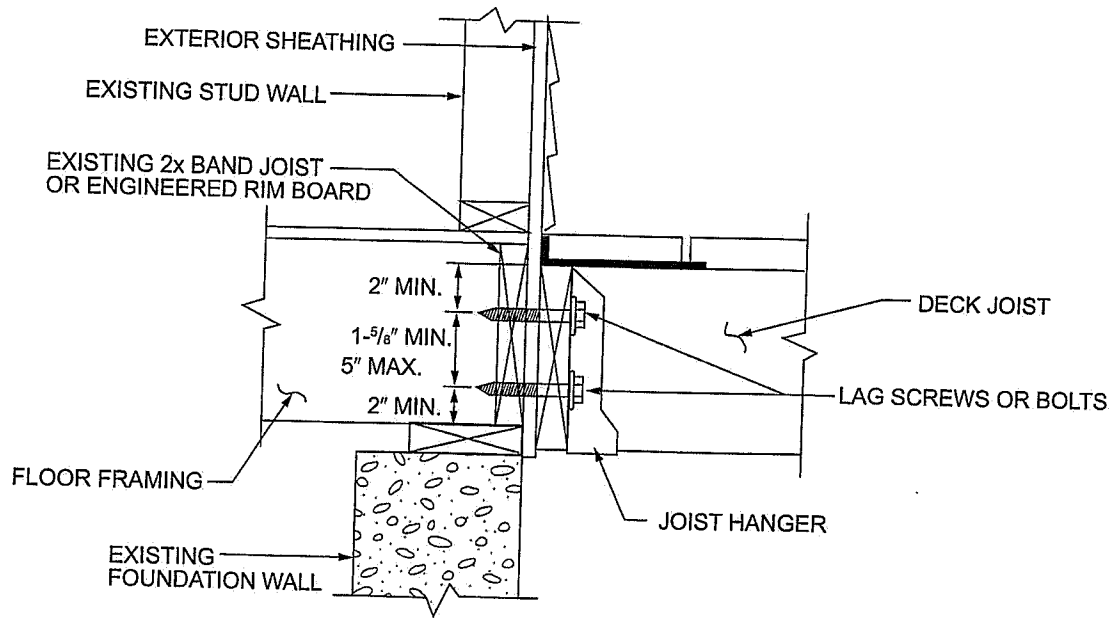

For SI: 1 inch = 25.4 mm.

PLACEMENT OF LAG SCREWS AND BOLTS IN BAND JOISTS

SUBMIT THIS SHEET WITH APPLICATION

Residential Deck

GUARDRAIL/HANDRAIL/STAIRS DETAIL

THE GREATEST RISER HEIGHT OR TREAD DEPTH SHALL NOT EXCEED THE SMALLEST BY MORE THAN 3/8".

CIRCLE EACH DETAIL THAT APPLIES

STAIRS WITH 4 OR MORE RISERS REQUIRE A HANDRAIL ON AT LEAST ONE SIDE WITH ADEQUATE GRASPABILITY.

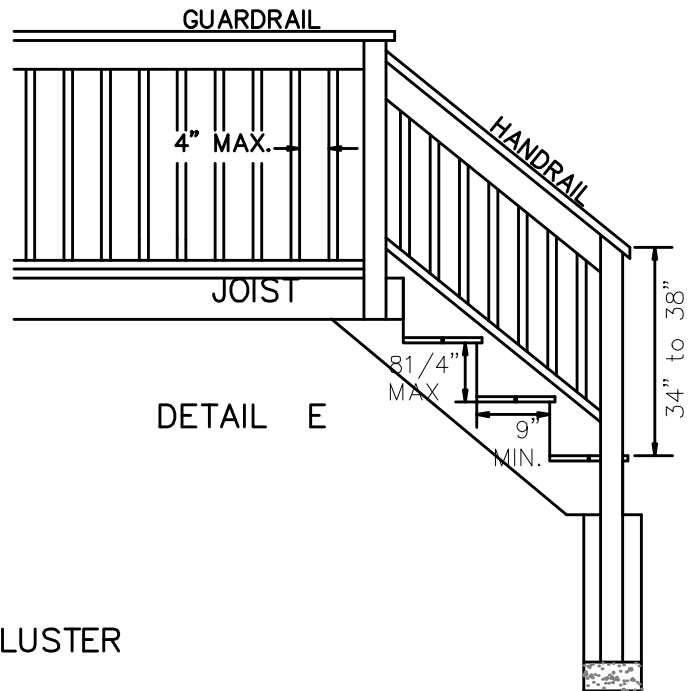

DETAIL E

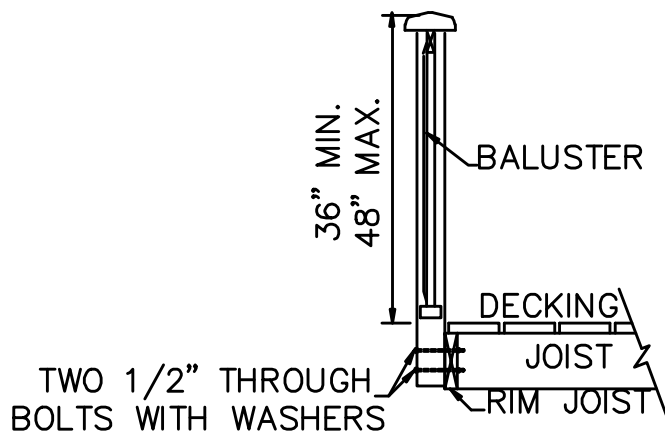

DETAIL D