

\\cmh01a01\proj\01\2021\0326\Draw\04\Sheets\DP\1 - Regional Context Map.dwg, Last Saved By: mmeric, 7/23/2021, 4:46 PM, Last Printed By: Neirci, Megan, 7/23/2021, 9:58 AM
4 Met: 20170444-PDP-1B, 20170444-CS-REF-E, 20170444-CS-REF-PDF-BLDGN, 20170444-CS-REF-PDF-REF-PDF-N

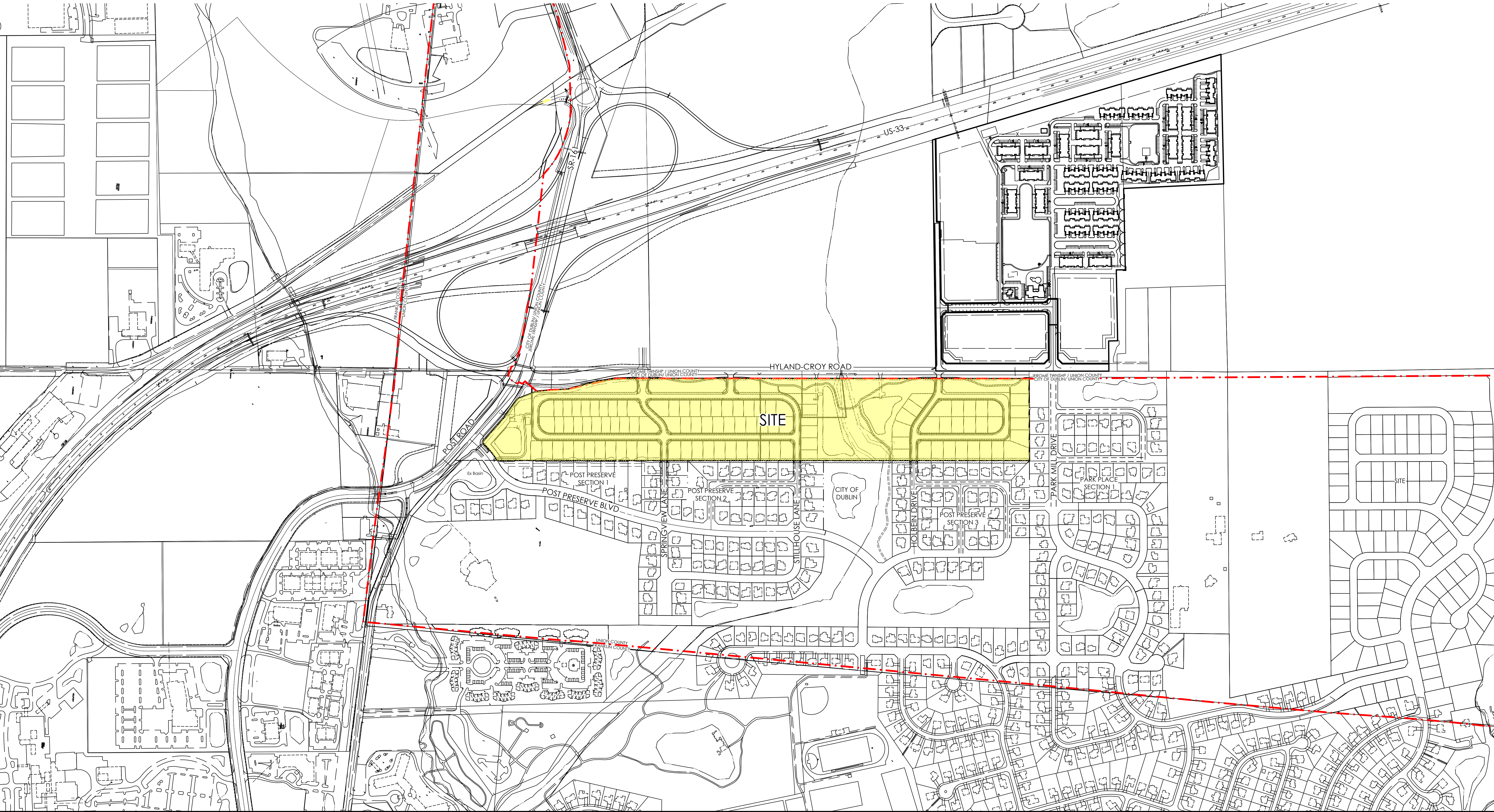

HYLAND GLEN

CITY OF DUBLIN, UNION COUNTY, OHIO
PRELIMINARY DEVELOPMENT PLAN

The Paragon Building Group, LTD.
dba Virginia Homes
485 Metro Place South
Suite 350
Dublin, Ohio 43017

PREPARED BY:



REGIONAL CONTEXT MAP

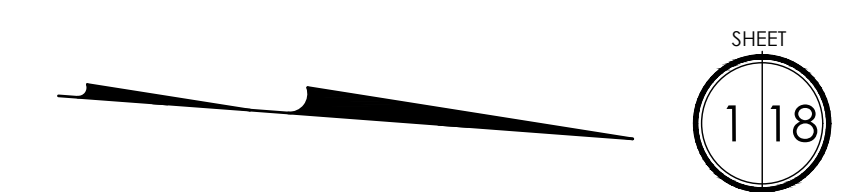
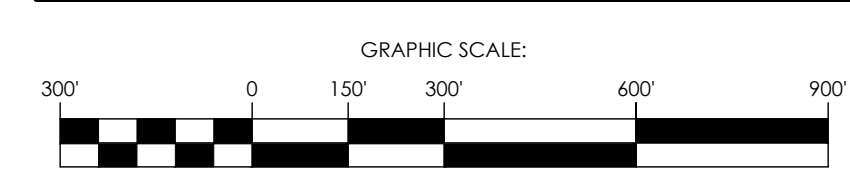

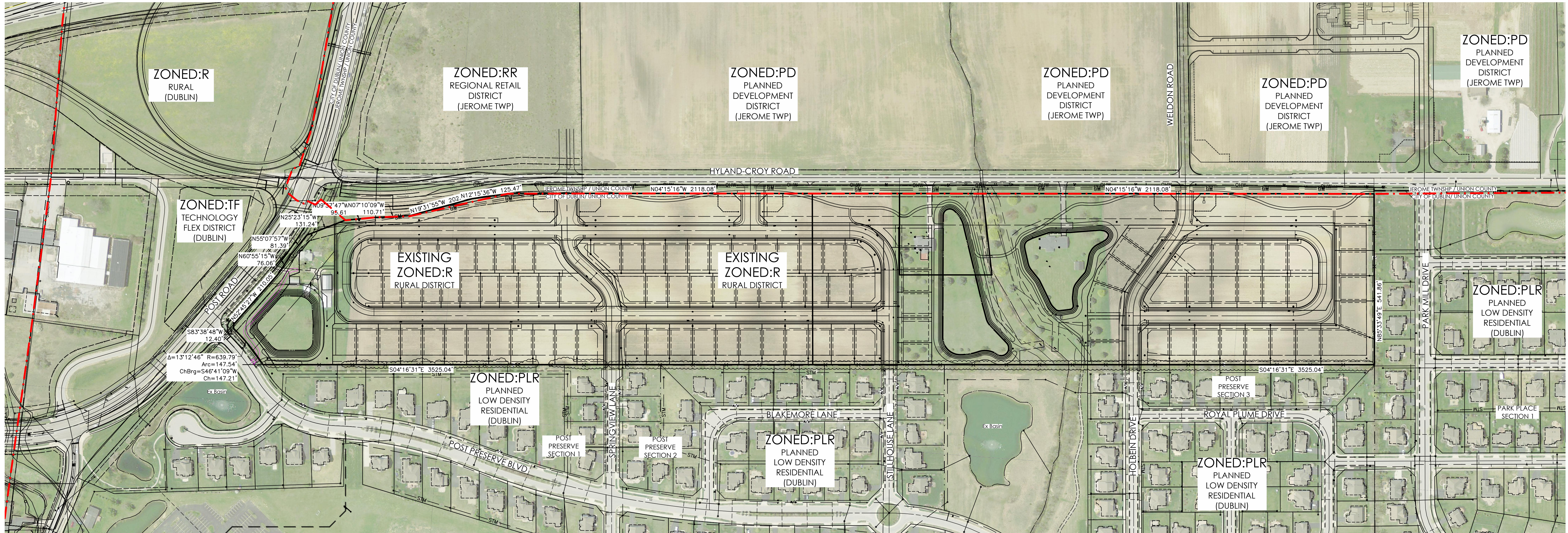

HYLAND GLEN

CITY OF DUBLIN, UNION COUNTY, OHIO

PRELIMINARY DEVELOPMENT PLAN

The Paragon Building Group, LTD.
 dba Virginia Homes
 485 Metro Place South
 Suite 350
 Dublin, Ohio 43017

PREPARED BY:



VICINITY MAP

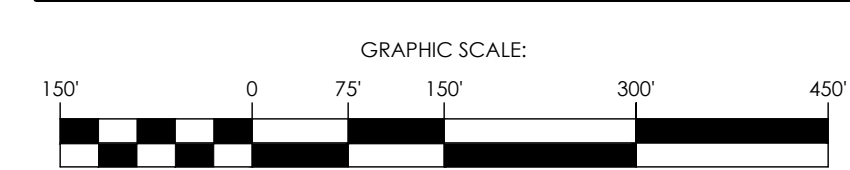

SHEET
 218

\\cmddat01\project01\20210326\Drawings\Sheets\POP\3_Vicinity_Map.dwg, Last Saved By: mmeirci, 7/26/2021 10:45 AM, Last Plotted By: Neicci, Neicci, 7/26/2021 10:46 AM
 4 Web: 20170464.PDF-1b, 20170464.CS-REFR-E, 20170464.CS-REFR-PDF-BLDG-N, 20170464.CS-REFR-PDF-N

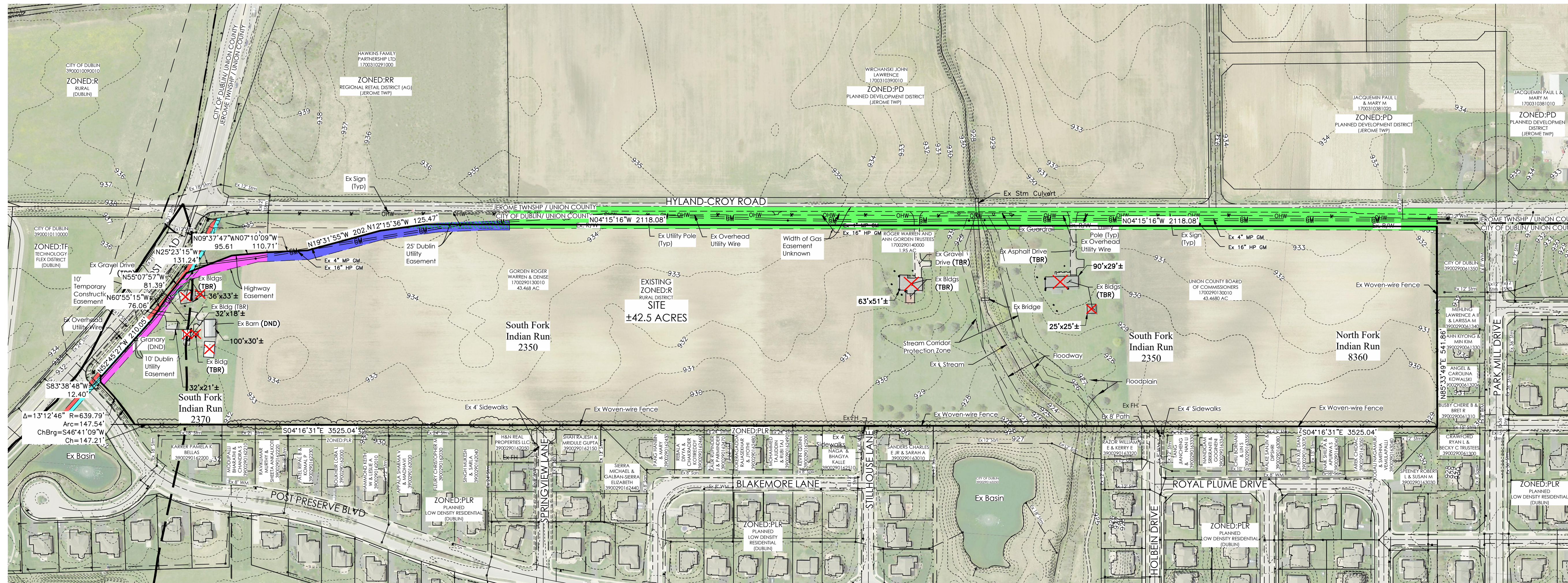

- KEY:**
- Gas Easement
 - Gas Easement
 - 25' Dublin Utility Easement
(No Description of Facilities Contained Within)
 - 10' Dublin Utility Easement
(No Description of Facilities Contained Within)
 - Highway Easement
 - 10' Temporary Construction Easement

NOTES:

See Tree Survey Plan, Sheets 18-19 for tree locations.

TBR - To Be Removed

DND - Do Not Disturb

HYLAND GLEN

CITY OF DUBLIN, UNION COUNTY, OHIO

PRELIMINARY DEVELOPMENT PLAN

The Paragon Building Group, LTD.
dba Virginia Homes
485 Metro Place South
Suite 350
Dublin, Ohio 43017

PREPARED BY:



EXISTING CONDITIONS

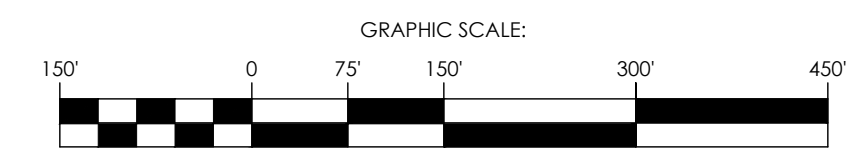

SHEET
318

\\cmddat01\project01\20210326\DWG\04\Sheets\FPP\3 Existing Conditions.dwg, Last Saved By: mmelech, 7/23/2021 1:49 PM, Last Printed By: mmelech, 7/23/2021 1:49 PM
 4 Ref: 20170464.PDF-1B, 20170464.CS-REF-E, 20170464.CS-REF-R, PDF-BLDG-N, 20170464.CS-REF-R, PDF-N



SITE STATISTICS:

TOTAL ACREAGE:	42.5 ACRES
TOTAL NUMBER OF LOTS:	102
GROSS DENSITY:	2.4 LOTS/ACRE
TOTAL OPEN SPACE REQUIRED:	6.46 ACRES/(15.2%)
- LAND DEDICATION:	
- 42.55 X .02 = 0.85 / ACRES	
- .03 X 102 LOTS = 3.06 ACRES	
	3.91 ACRES
- RECREATIONAL FACILITIES:	
- 0.025 X 102 = 2.55 ACRES	
TOTAL OPEN SPACE PROVIDED:	±12.4 ACRES/(29.1%)

HYLAND GLEN

CITY OF DUBLIN, UNION COUNTY, OHIO
PRELIMINARY DEVELOPMENT PLAN

The Paragon Building Group, LTD.
dba Virginia Homes
485 Metro Place South
Suite 350
Dublin, Ohio 43017

PREPARED BY:



ILLUSTRATIVE PLAN

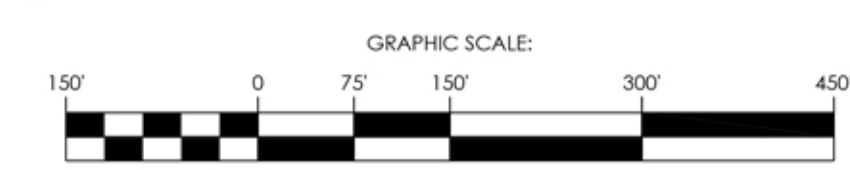

\cmtdata\01\20210326\Draw\04\Sheets\PDF\4 Illustrative Plan.dwg, Last Saved By: mmeier, 7/23/2021 11:14 AM, Last Printed By: Neicci, Megan, 4/17/2017 1:09 PM
 4 Xrefs: 20170464-PDF-1B, 20170464-CS-REF-E, 20170464-CS-REF-P, 20170464-CS-REF-R, 20170464-CS-REF-N

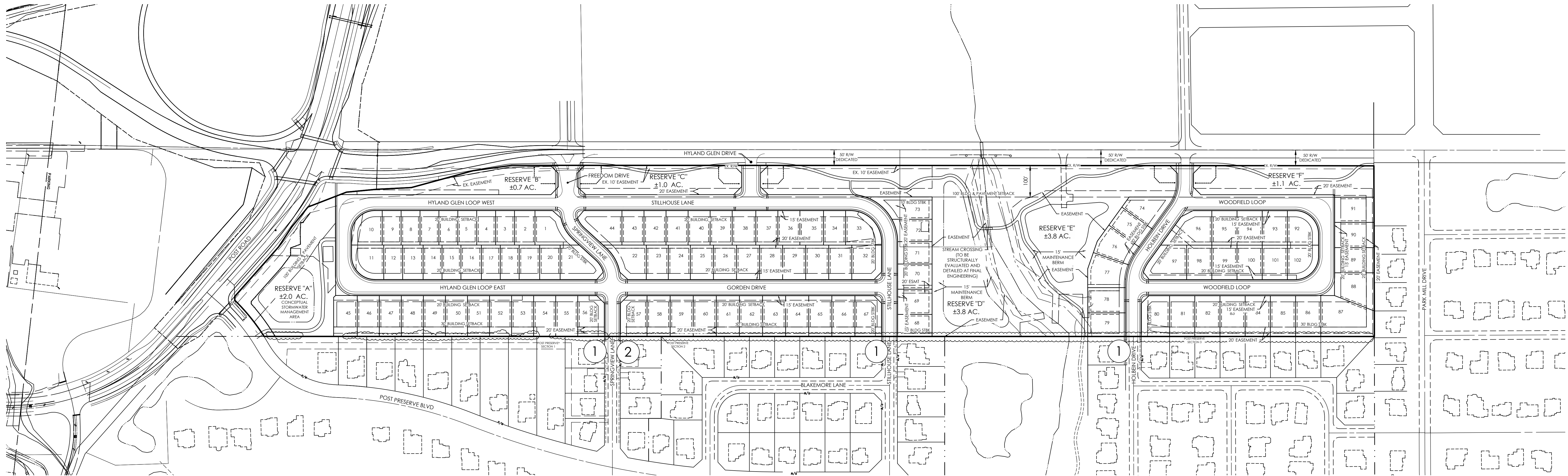

NOTES:

①	Proposed Public Streets will be Connected to Existing Streets
②	Existing Hammerhead at Springview Lane to be Removed; as Existing Easements Allow, with Street Connection to Proposed Development

SITE STATISTICS:

TOTAL ACREAGE:	42.5 ACRES
TOTAL NUMBER OF LOTS:	102
GROSS DENSITY:	2.4 LOTS/ACRE
TOTAL OPEN SPACE REQUIRED:	6.46 ACRES/(15.2%)
- LAND DEDICATION:	
- 42.55 X .02 = 0.85 / ACRES	
- .03 X 102 LOTS = 3.06 ACRES	
	3.91 ACRES
- RECREATIONAL FACILITIES:	
- 0.025 X 102 = 2.55 ACRES	
TOTAL OPEN SPACE PROVIDED:	±12.4 ACRES/(29.1%)

HYLAND GLEN

CITY OF DUBLIN, UNION COUNTY, OHIO
PRELIMINARY DEVELOPMENT PLAN

The Paragon Building Group, LTD.
dba Virginia Homes
485 Metro Place South
Suite 350
Dublin, Ohio 43017

PREPARED BY:



SITE PLAN

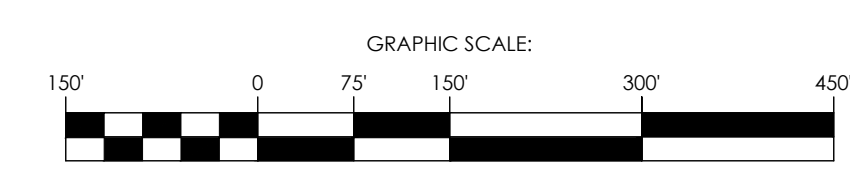

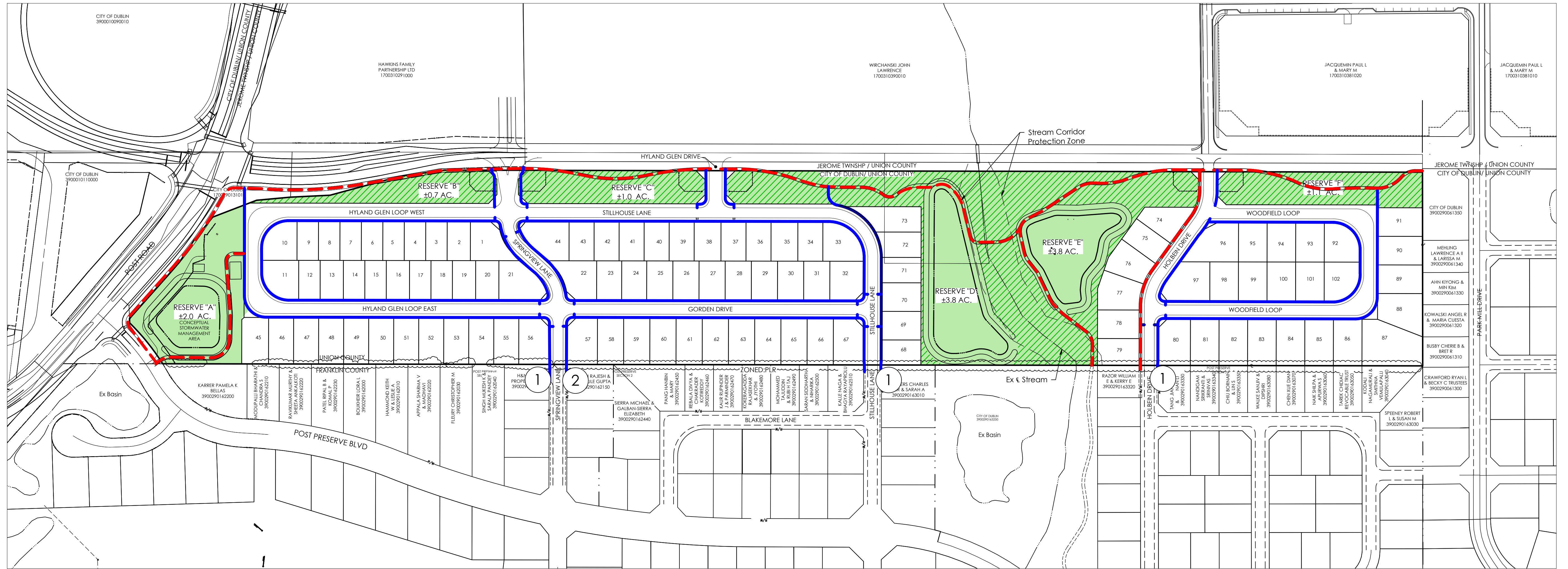

NOTES:

①	Proposed Public Streets will be Connected to Existing Streets
②	Existing Hammerhead at Springview Lane to be Removed; as Existing Easements Allow, with Street Connection to Proposed Development

RESERVE OWNERSHIP/MAINTENANCE PLANS

Reserve	Ownership	Maintained By
Reserve "A"	CITY	CITY
Reserve "B"	CITY	HOA
Reserve "C"	CITY	HOA
Reserve "D"	CITY	City/HOA*
Reserve "E"	CITY	City/HOA*
Reserve "F"	CITY	HOA*

* The City Shall Maintain Storm Water Management Basins and Appurtenances thereto which Serve Storm Water Functionality

KEY

- 8" PEDESTRIAN PATH (OWNED & MAINTAINED BY CITY)
- 5' SIDEWALK
- OPEN SPACE - AREA TO BE MAINTAINED BY CITY
- OPEN SPACE - AREA TO BE MAINTAINED BY HOA

OPEN SPACE

TOTAL OPEN SPACE REQUIRED: 6.46 ACRES/(15.2%)

- LAND DEDICATION:
 - 42.5 X .02 = 0.85 / ACRES
 - .03 X 102 LOTS = 3.06 ACRES
- RECREATIONAL FACILITIES:
 - 0.025 X 102 = 2.55 ACRES

TOTAL OPEN SPACE PROVIDED: ±12.4 ACRES/(29.1%)

HYLAND GLEN

CITY OF DUBLIN, UNION COUNTY, OHIO
PRELIMINARY DEVELOPMENT PLAN

The Paragon Building Group, LTD.
dba Virginia Homes
485 Metro Place South
Suite 350
Dublin, Ohio 43017

PREPARED BY:

Evans, Mechwart, Hambleton & Titon, Inc.
Engineers • Surveyors • Planners • Scientists
5500 New Albany Road, Columbus, OH 43054
Phone: 614.775.4500 Tel. Fax: 688.775.3688
emht.com

OPEN SPACE & CONNECTIVITY PLAN

GRAPHIC SCALE: 150' 0 75 150 300 450'

HYLAND GLEN JULY 26, 2021 20210326

SHEET 618

\\cmf\datad\1\proj\01\20210326\HylandGlen\03\sheet\1\DP17_Clean_Space_Connectivity.dwg, Last Saved By: mmerid, 7/23/2021 1:58 PM, Last Printed By: Nelci, Megan, 7/23/2021 1:59 PM
 4 Wers, 2017/04/14 11:41:11, 2017/04/14 11:41:11, 2017/04/14 11:41:11, 2017/04/14 11:41:11, 2017/04/14 11:41:11

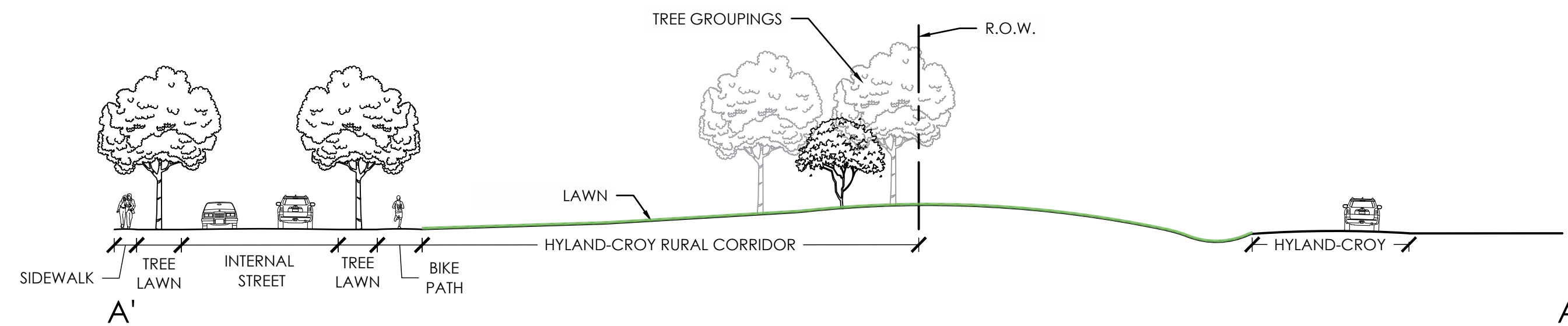

HYLAND-CROY TYPICAL RURAL CORRIDOR SECTION ELEVATION

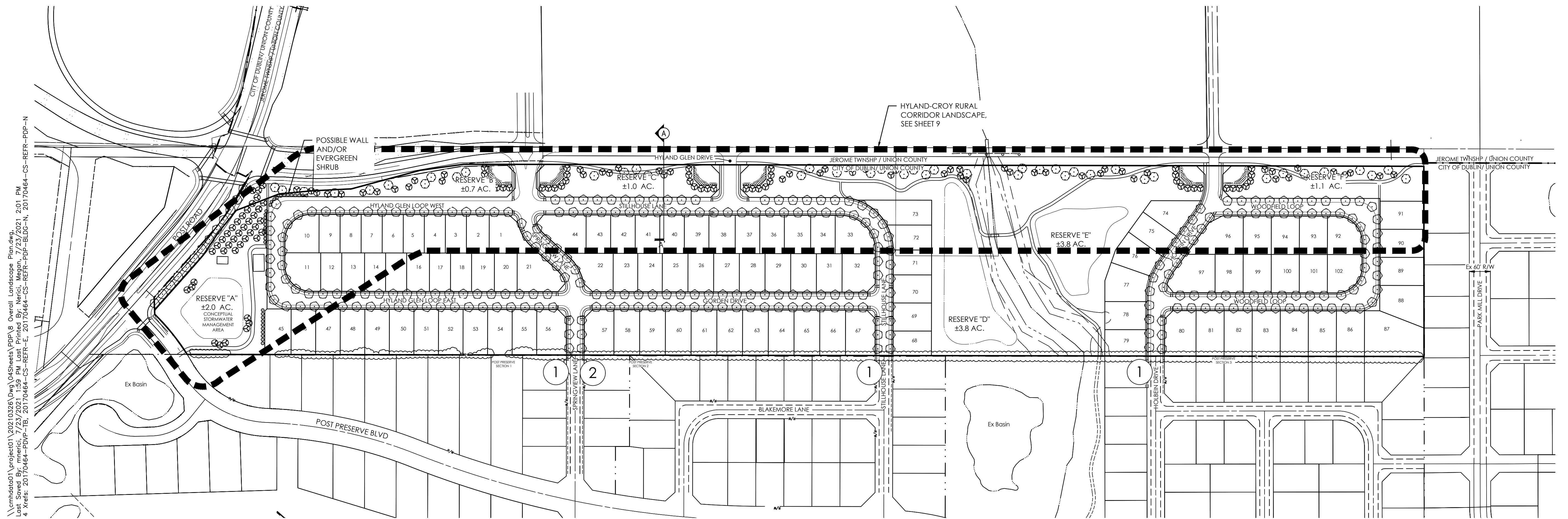

\\erhdata06\project01\20210326\04\Sheets\PPP\8 Overall Landscape Planning
 L:\erhdata06\project01\20210326\04\Sheets\PPP\8 Overall Landscape Planning
 4 Xrefs: 20170464-PDP-IB, 20170464-CS-REFR-E, 20170464-CS-REFR-PDF-BLDG-N, 20170464-CS-REFR-PDF-N

NOTES:	
①	Proposed Public Streets will be Connected to Existing Streets
②	Existing Hammerhead at Springview Lane to be Removed; as Existing Easements Allow, with Street Connection to Proposed Development

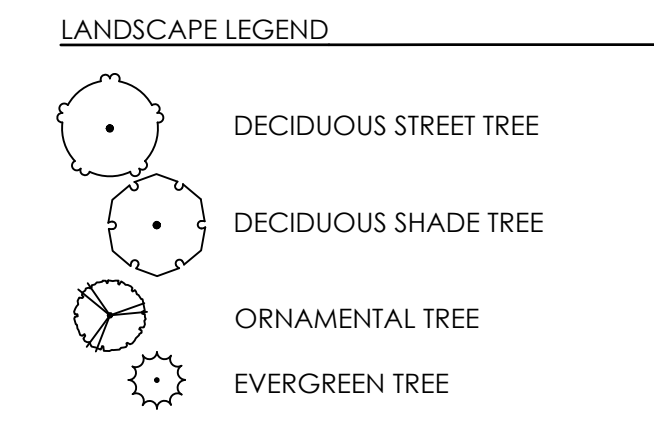

- Notes:
1. Landscape materials shall be selected to be tolerant of wet, dry, and windy conditions.
 2. Stormwater basin shall provide either one (1) fountain or aerator per basin.

HYLAND GLEN

CITY OF DUBLIN, UNION COUNTY, OHIO
PRELIMINARY DEVELOPMENT PLAN

The Paragon Building Group, LTD.
 dba Virginia Homes
 485 Metro Place South
 Suite 350
 Dublin, Ohio 43017

PREPARED BY:

 Evans, Mechwart, Hambleton & Titon, Inc.
 Engineers • Surveyors • Planners • Scientists
 5500 New Albany Road, Columbus, OH 43054
 Phone: 614.775.4500 Tel. Free: 888.775.3648
 emht.com

OVERALL LANDSCAPE PLAN

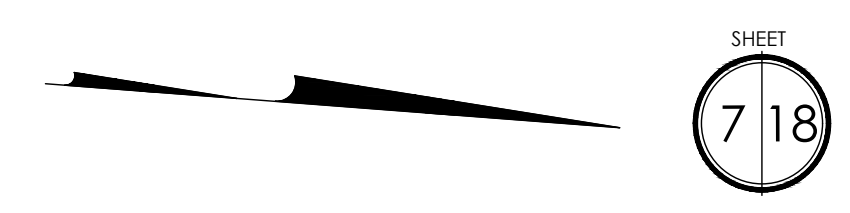
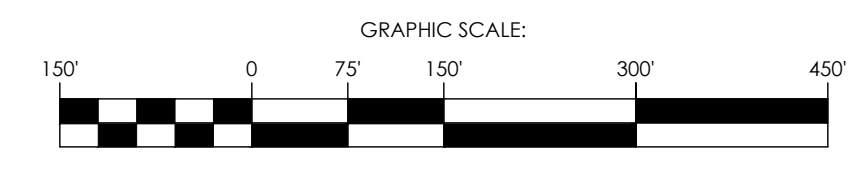

\\cmhdat01\project01\20210326\04Sheets\04Sheets\04\10 Landscape Notes & Details.dwg, Last Saved By: mmerici, 7/23/2021 12:13 PM Last Printed By: Neñici, Megan, 7/23/2021 12:15 PM
4 Xrefs: 20170464-PDP-N, 20170464-CS-REFR-PDP-BLDG-N, 20170464-CS-REFR-PDP-N, 20170464-CS-REFR-PDP-N, 20170464-CS-REFR-PDP-N

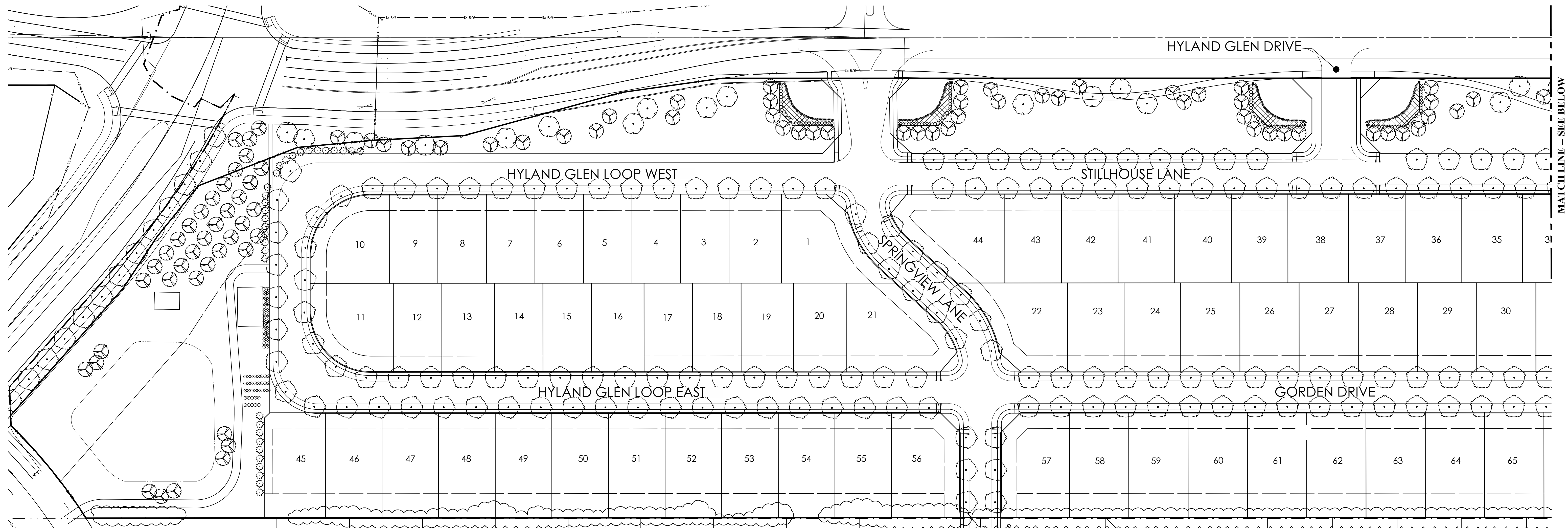

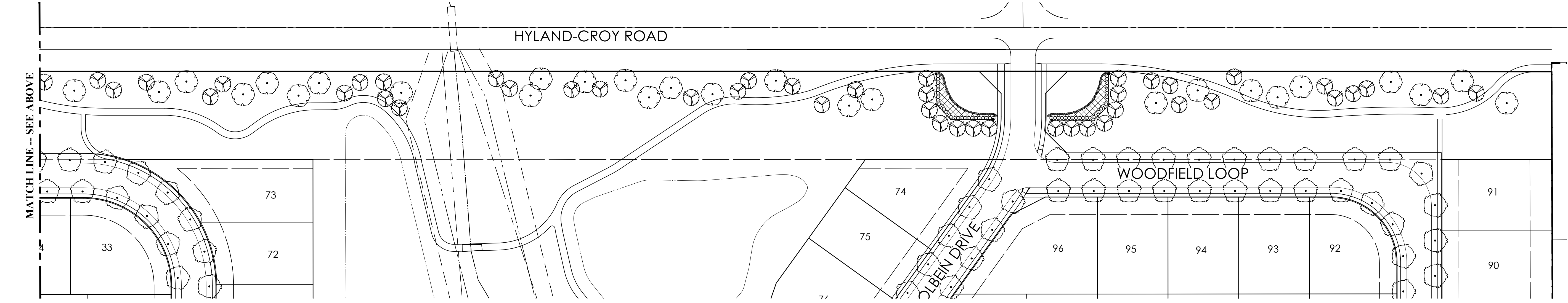

HYLAND-CROY RURAL CORRIDOR
LANDSCAPE ENLARGEMENT

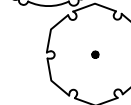

HYLAND-CROY RURAL CORRIDOR
LANDSCAPE ENLARGEMENT

LANDSCAPE LEGEND

-  DECIDUOUS STREET TREE
-  DECIDUOUS SHADE TREE
-  ORNAMENTAL TREE
-  EVERGREEN TREE

NOTE: ALL LANDSCAPING,
FENCING, AND ENTRY
FEATURES ARE CONCEPTUAL
WILL BE PROVIDED AT FDP

HYLAND GLEN

CITY OF DUBLIN, UNION COUNTY, OHIO
PRELIMINARY DEVELOPMENT PLAN

The Paragon Building Group, LTD.
dba Virginia Homes
485 Metro Place South
Suite 350
Dublin, Ohio 43017

PREPARED BY:



HYLAND-CROY RURAL CORRIDOR ENLARGEMENT

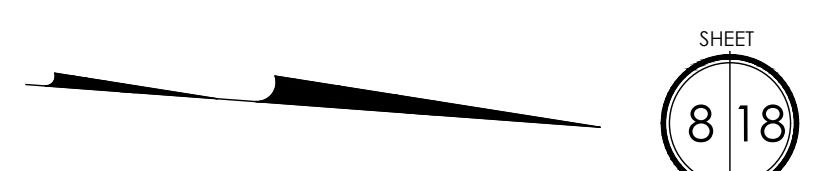
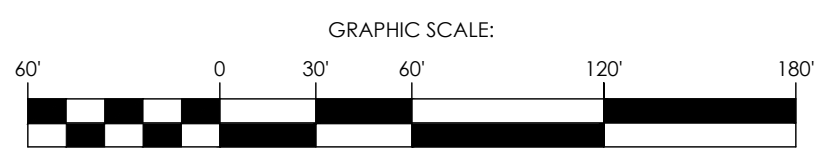

SHEET
8 18

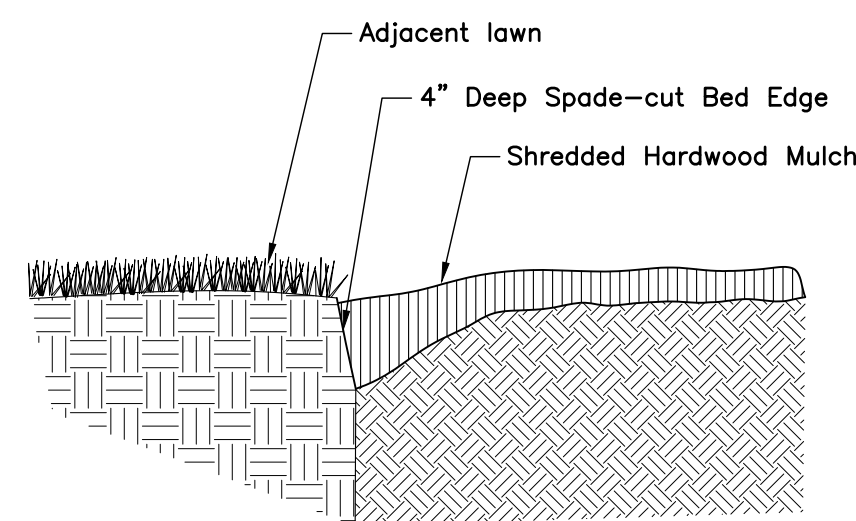

Planting Bed Edge
No Scale

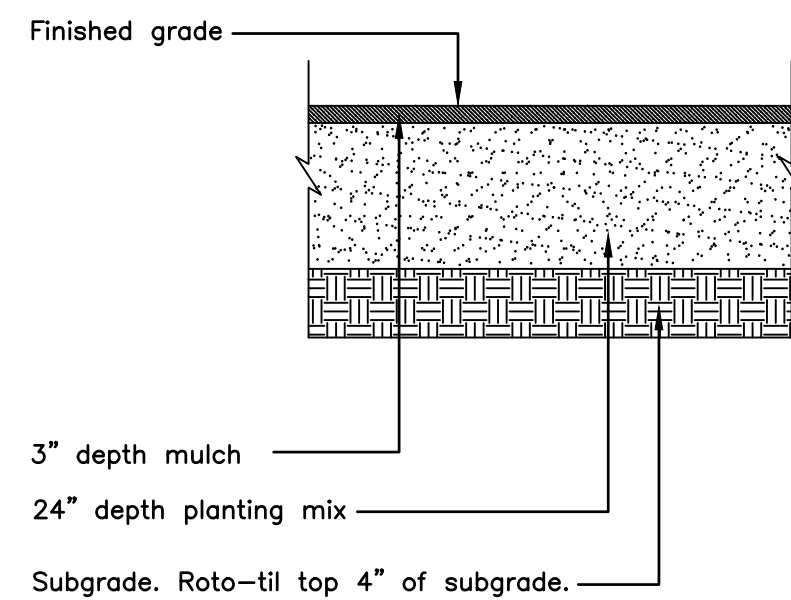

Planting Area Establishment
No Scale

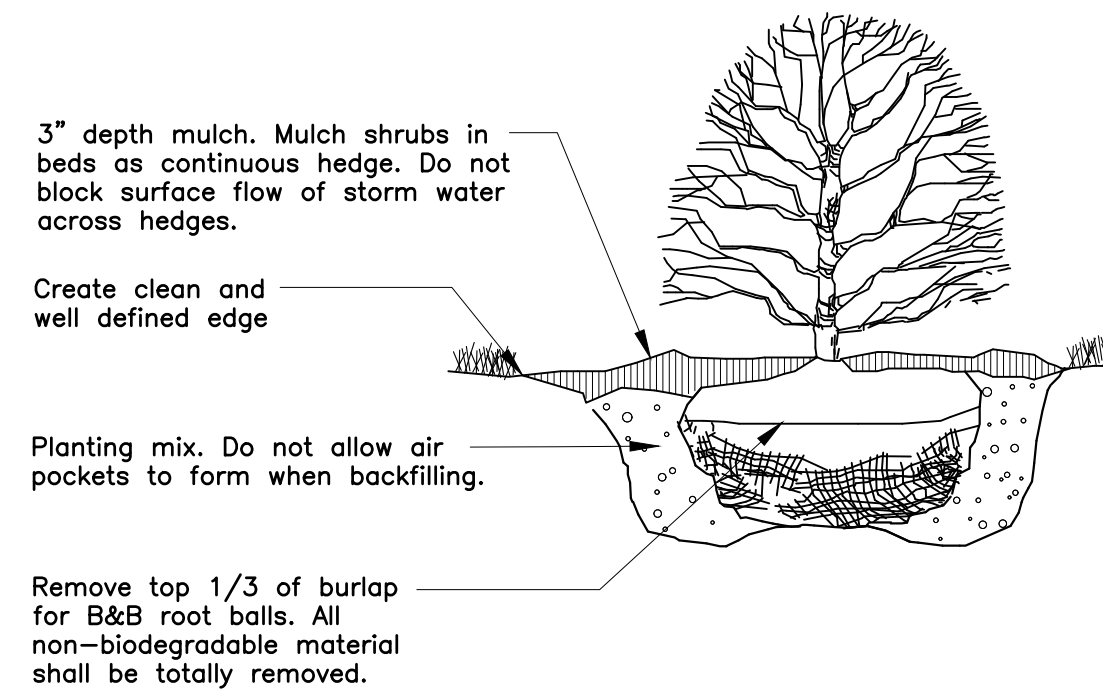

Shrub Planting
No Scale

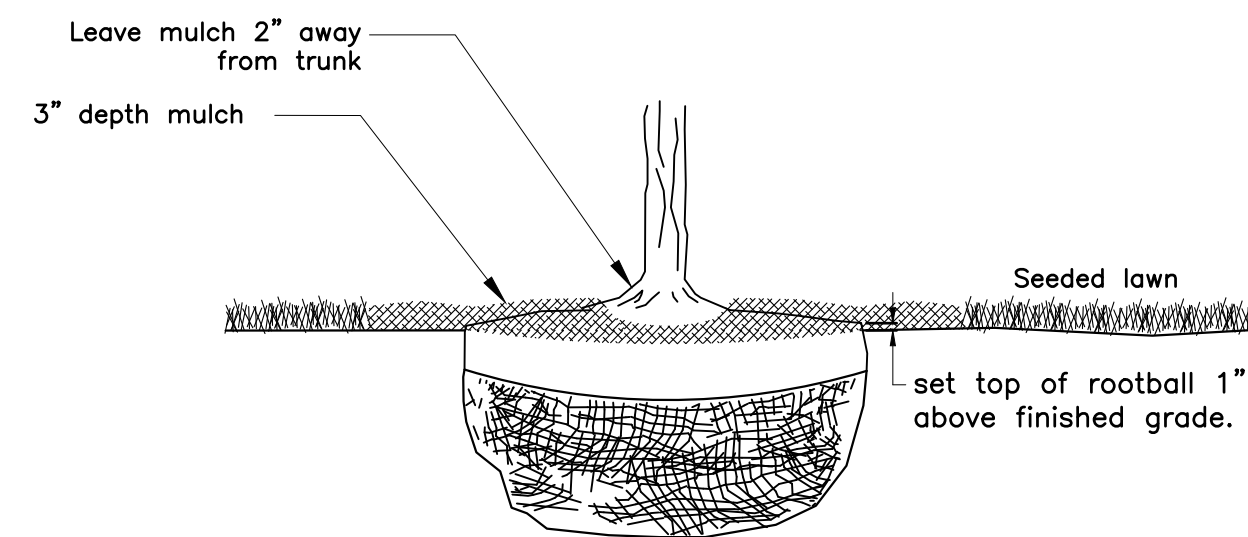

Rootball Setting
No Scale

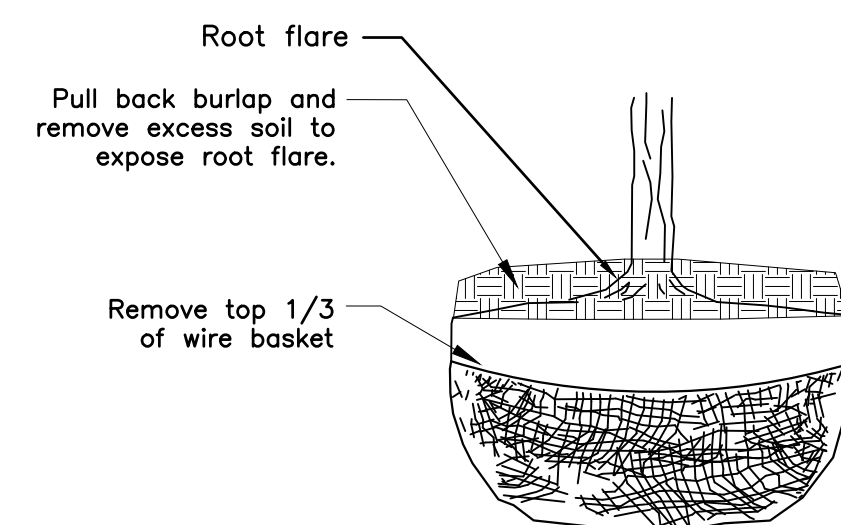

Rootball Preparation
No Scale

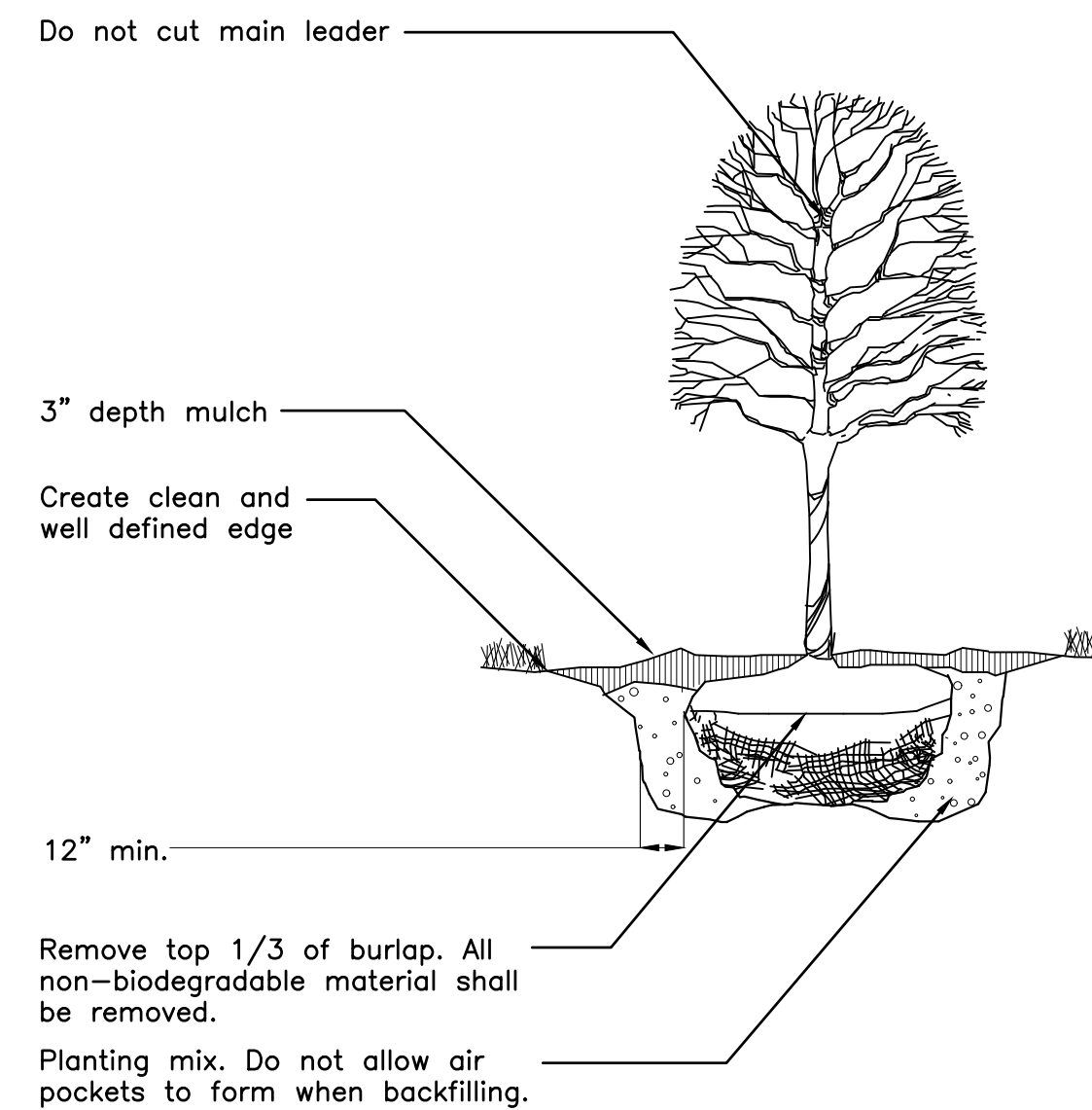

Deciduous Tree Planting
No Scale

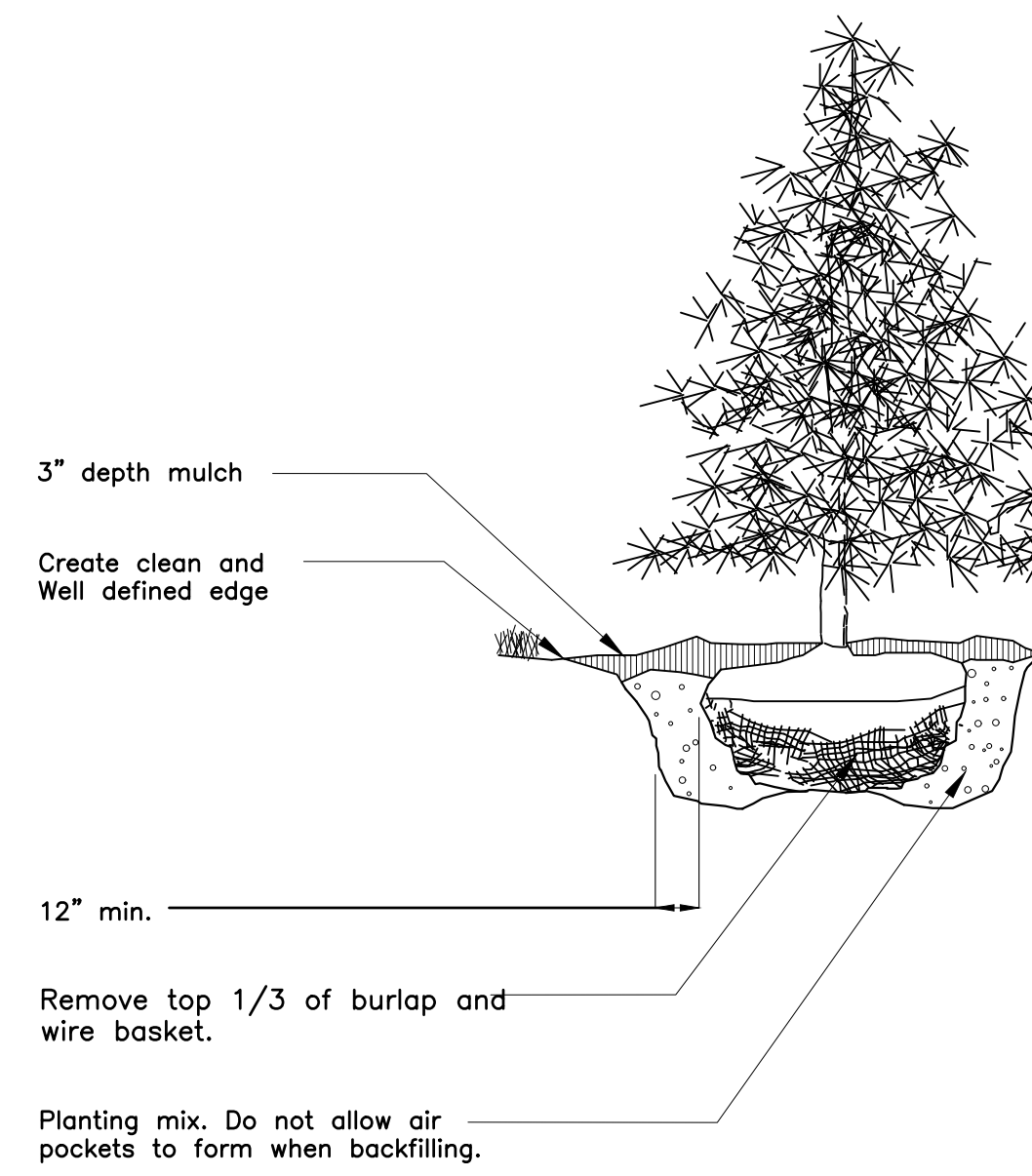

Evergreen Tree Planting
No Scale

GENERAL NOTES

1. Prior to installation, the landscape contractor shall inspect the general site conditions and verify the subgrade, elevations, utility locations and topsoil provided by general contractor. The landscape contractor shall notify the general contractor of any unsatisfactory conditions and work shall not proceed until such conditions have been corrected and are acceptable to the landscape contractor.
2. All plants shall meet or exceed standards set in the American Standard for Nursery Stock, ANSI Z60.1, current edition. All plants shall equal or exceed the measurements and sizes specified in the schedule.
3. Substitutions shall only be permitted with notification and written approval from the Owner. Substituted material shall be equivalent or greater in size than the specified plant. Substituted plants shall have the same essential characteristics and growth habit of the specified plant.
4. Confirm location of all utilities and subsurface drain lines prior to plant installation.
5. A pre-installation conference shall be conducted prior to planting operations with Owner and Contractor present.
6. Contractor may slightly field adjust plant locations as necessary to avoid utilities. Finished planting beds shall be graded to provide positive drainage.
7. Irrigation system, if applicable, shall be complete and operational prior to landscape planting.
8. Contractor shall repair all lawn areas disturbed during construction with seed and warrant a healthy, weed free lawn prior to project acceptance.
9. Seed all areas within contract limits that are not covered by paving, buildings or planting beds unless otherwise noted. Seeding shall not begin until area has received topsoil and finished grade.
10. Mulch planting beds with shredded hardwood mulch of uniform dark brown color. It shall be free of twigs, leaves, disease, pest or other material unsightly or injurious to plants. Average applied thickness shall be 3" depth. Mulch hedges in a continuous bed.
11. Planting beds shall be covered with pre-emergent herbicide applied at product specified rate unless otherwise noted.
12. Bed edge shall be smooth, consistent, hand trenched 4" deep and "V" shaped unless otherwise noted. All excavated material shall be removed from the bed edge and planting bed.
13. All planting bed edges to be smooth flowing arcs or straight lines as shown on plan. Plant locations and layout of beds shall be located by Contractor and approved by Landscape Architect prior to planting.
14. Install all plants in accordance with planting details and specifications.
15. Parking lot and street trees shall have a clear canopy height of 6' min.
16. Trees shall be placed a minimum of 3' from sidewalks and curbs.
17. Planting Mix shall be blended, manufactured soil consisting of three (3) parts topsoil, one (1) part compost, one (1) part sand. Topsoil shall be per ASTM D5268, ph range of 5.5 to 7, min. 4 percent organic material, free of stones and soil clumps 3/4 inch and larger. Compost shall be yard waste compost from an EPA rated Class IV compost facility or Com-til compost from City of Columbus Department of Public Utilities. Sand shall be per Item ASTM C33. Proprietary manufactured Planting Mix such as Kurtz Bros. Professional Blend or Jones SuperSoil may be used. Submit product data for review by Owner. Place Planting Mix in settled 6 inch lifts.
18. Mix Mycorrhizal Fungi into Planting Mix during placement of Planting Mix. Application rate shall be according to manufacturer's written recommendations. Mycorrhizal Fungi shall be a dry, granular inoculant containing vesicular-arbuscular mycorrhizal fungi and ectomycorrhizal fungi.
19. Excavate planting beds to a depth of 24 inches, unless otherwise indicated. Roto-til subgrade of excavation to a depth of 4 inches, unless otherwise indicated. Incorporate a 6 inch lift of planting mix into subgrade. Place remaining Planting Mix in settled 6 inch lifts.
20. Planting beds, including mulch, shall be no higher than 6 inches above adjacent grade and shall not impede surface drainage.
21. Lawn areas shall be backfilled with Planting Mix to a minimum settled thickness of 6 inches. Roto-Til subgrade below lawns to a depth of 4 inches, unless otherwise indicated, prior to placement of Planting Mix.
22. All trees and shrubs shall be fertilized with controlled release tablets of 20-10-5 composition. Size and number of tablets shall be per manufacturer's instructions.
23. Composition and application rate of lawn fertilizer shall be sufficient to amend soil according to recommendations of a qualified soil testing agency. Submit soil test results and amendment recommendations to Owner. Lawn fertilizer shall be in a dry granular form.
24. Contractor to determine plant list quantities from the plan. Graphic representation on plan supersedes in case of discrepancy with quantities on schedule.
25. Any item or areas damaged during construction shall be repaired or replaced to its original condition at the contractor expense.
26. Contractor shall thoroughly water all plants at time of installation and as needed until project acceptance by owner. Contractor shall guarantee all plants installed (except annuals) for one full year from date of acceptance by the Owner. All plants shall be alive and at a vigorous rate of growth at the end of the guarantee period.
27. All annuals to be provided by Contractor from available seasonal stock.
28. Lawn seed mix shall be proportioned by weight as follows: 80 percent Quest, Inferno, Arid 3 and/or Pixie Tall Fescue (select 2). Sodded lawns shall match seeded lawns; 10 percent Caddieshack or GoalKeeper Perennial Ryegrass; 10 percent NuBlue or Blue Chip Kentucky Bluegrass. Seeding rate shall be 8-10 pounds per 1000 square feet.
29. Lawn seed shall not have less than 95 percent germination, not less than 85 percent pure seed, and not more than 0.5 percent weed seed.

\\cmdata01\project01\20210326\Drawings\04\Sheets\pdp\10 Landscape Notes & Details.dwg, Last Saved By: mmerci, 7/22/2021 4:56 PM, Last Printed By: mmerci, 7/23/2021 11:00 AM
 4 Xrefs: 20170464-PDP-TB, 20170464-CS-REFR-E, 20170464-CS-REFR-PDP-TB, 20170464-CS-REFR-BLDG-N, 20170464-CS-REFR-PDP-N

HYLAND GLEN

CITY OF DUBLIN, UNION COUNTY, OHIO
PRELIMINARY DEVELOPMENT PLAN

The Paragon Building Group, LTD.
dba Virginia Homes
485 Metro Place South
Suite 350
Dublin, Ohio 43017

PREPARED BY:



LANDSCAPE NOTES & DETAILS

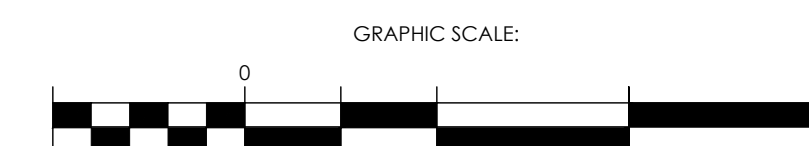

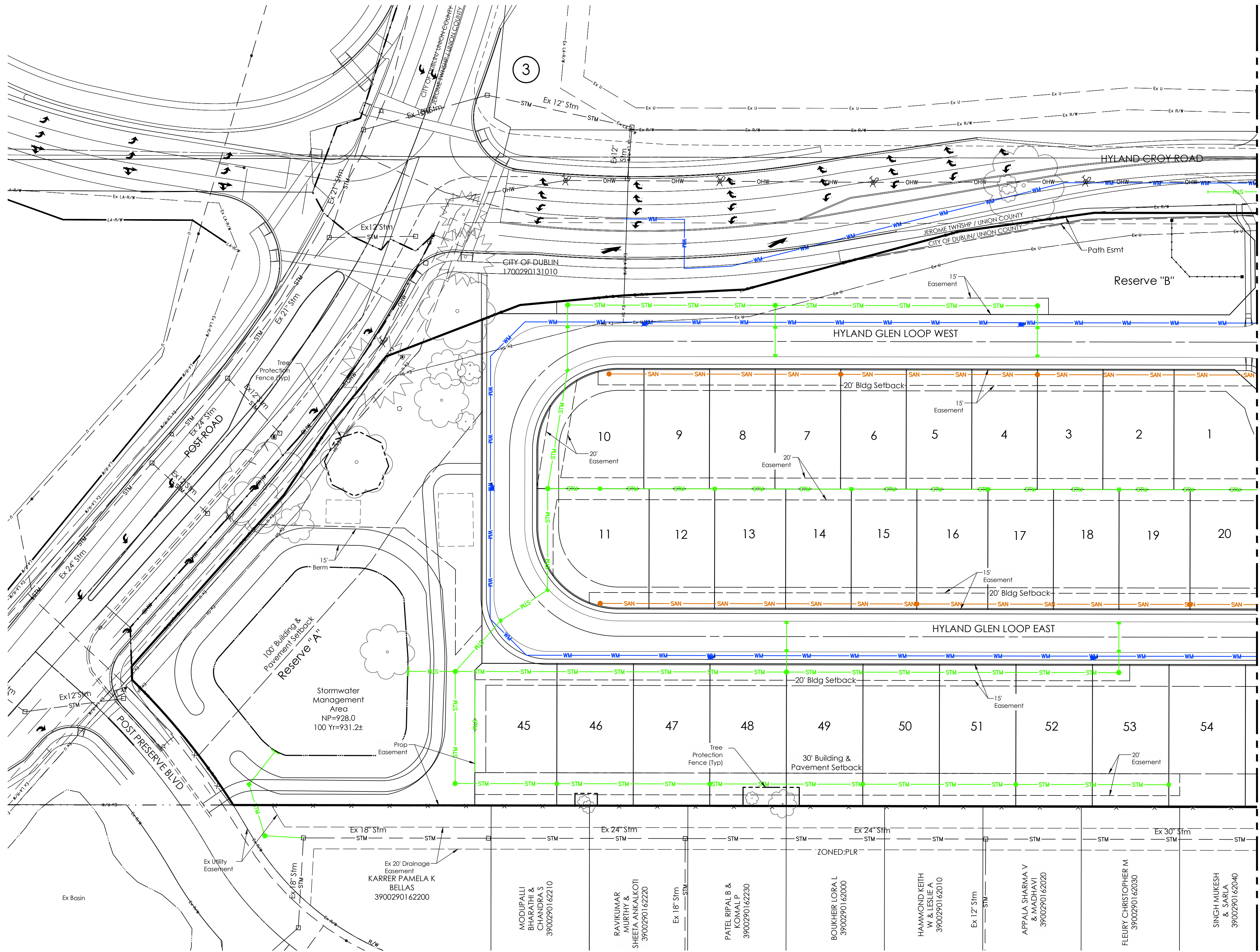

NOTES:

①	Proposed Public Streets will be Connected to Existing Streets
②	Existing Hammerhead at Springview Lane to be Removed; as Existing Easements Allow, with Street Connection to Proposed Development
③	Future Post Road/Hyland Croy Road Improvements Shown for Reference Only

Existing Utilities	
STM	Storm Sewer
SAN	Sanitary Sewer
WM	Water
E	Underground Electric
C	Underground Communication
GM	Gas
UGL	Underground Street Lighting
OHW	Overhead Electric/Communication
Proposed Utilities	
STM	Storm Sewer
SAN	8" Sanitary Sewer Main
WM	Public Water Main

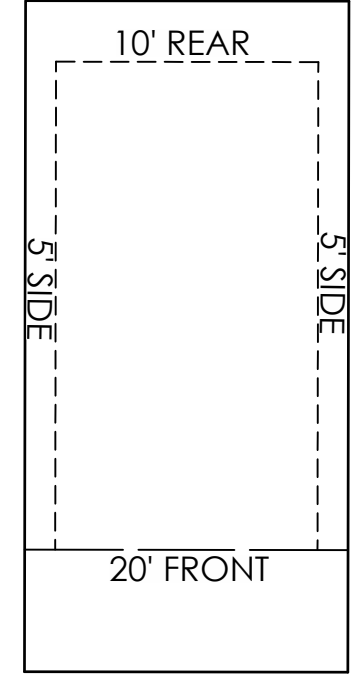

HYLAND GLEN

CITY OF DUBLIN, UNION COUNTY, OHIO
PRELIMINARY DEVELOPMENT PLAN

The Paragon Building Group, LTD.
dba Virginia Homes
485 Metro Place South
Suite 350
Dublin, Ohio 43017

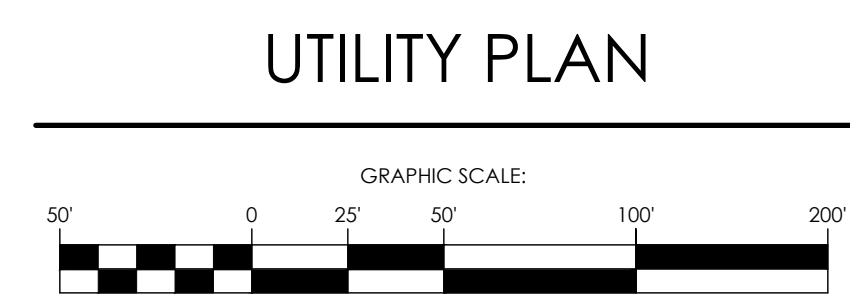

J:\2021\0326\DWG\04sheets\PDF\13 Utility Plan.dwg, Last Saved By: Ivanover, 7/23/2021 11:35 AM, Last Printed By: Berry, Sydney, 7/23/2021 12:44 PM
 4 Xrefs: 20170464-PDPV-1B, 20170464-CS-REFR-E, 20170464-CS-REFR-PDP-BDC-N, 20170464-CS-REFR-PDP-PDP-N

NOTES:

①	Proposed Public Streets will be Connected to Existing Streets
②	Existing Hammerhead at Springview Lane to be Removed; as Existing Easements Allow, with Street Connection to Proposed Development
③	Future Post Road/Hyland Croy Road Improvements Shown for Reference Only

LEGEND

Existing Utilities	
STM	Storm Sewer
SAN	Sanitary Sewer
WM	Water
E	Underground Electric
C	Underground Communication
GM	Gas
UGL	Underground Street Lighting
OHW	Overhead Electric/Communication
Proposed Utilities	
STM	Storm Sewer
SAN	8" Sanitary Sewer Main
WM	Public Water Main

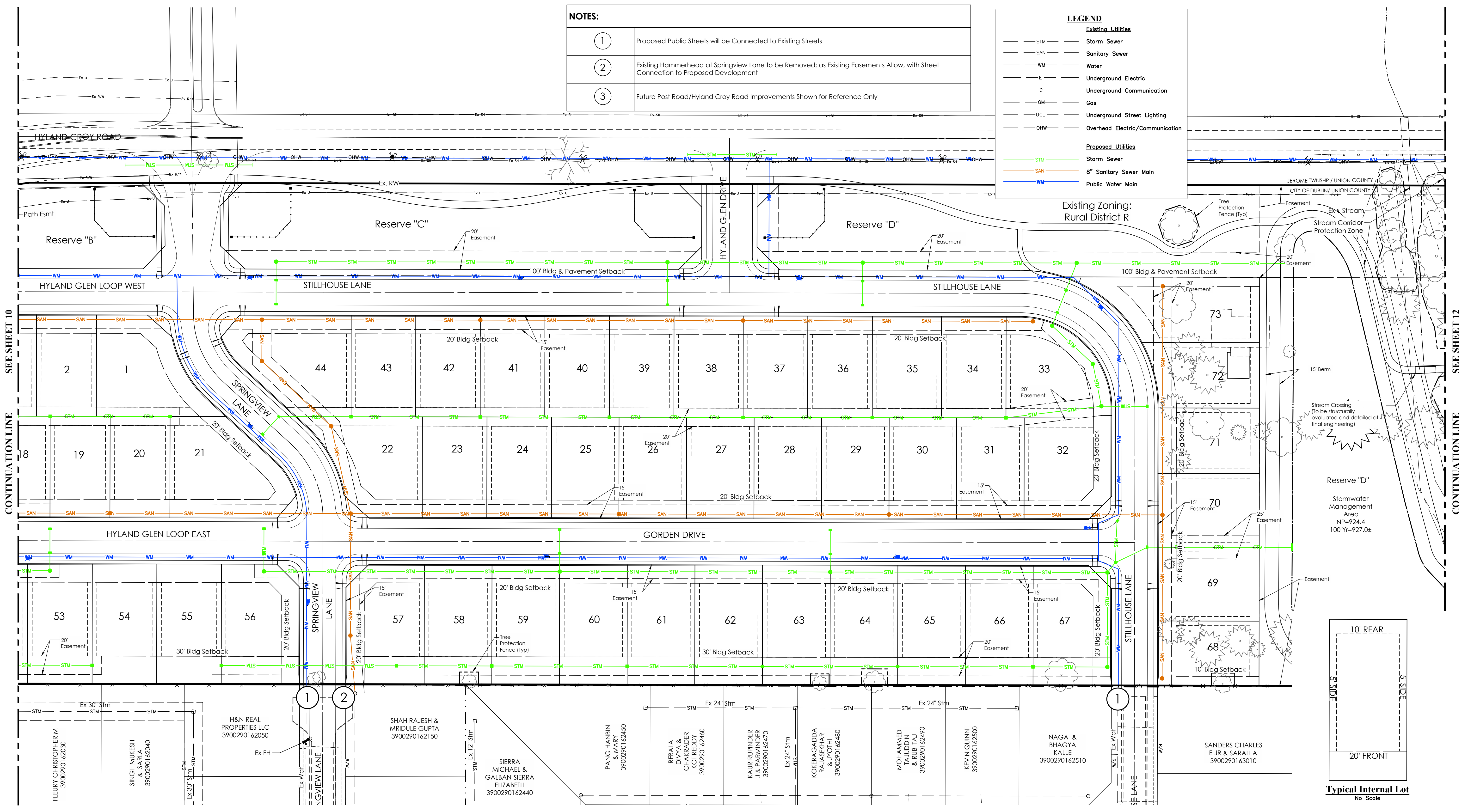

HYLAND GLEN

CITY OF DUBLIN, UNION COUNTY, OHIO
PRELIMINARY DEVELOPMENT PLAN

The Paragon Building Group, LTD.
dba Virginia Homes
485 Metro Place South
Suite 350
Dublin, Ohio 43017

PREPARED BY:

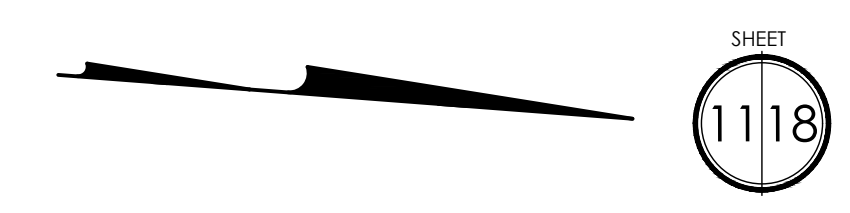
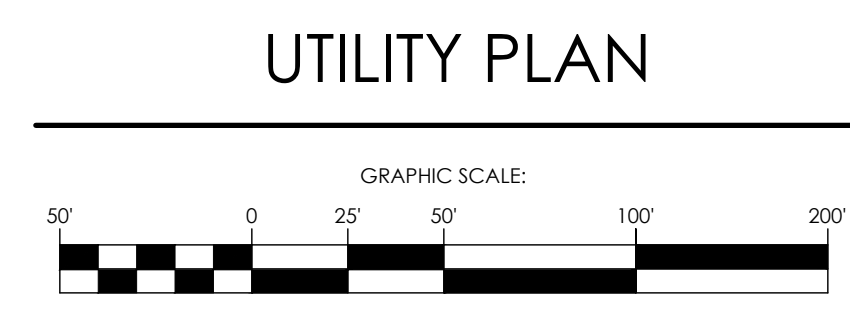

SHEET
1118

I:\2021\0326\Drawings\04\Sheets\PDPA\13_Utility Plan.dwg, Last Saved By: naporver, 7/23/2021 11:35 AM, Last Printed By: Vanover, Linda, 7/23/2021 11:49 AM
 4 Xrefs: 20170464-PDP-1B, 20170464-CS-REFR-E, 20170464-CS-REFR-FDP, 20170464-CS-REFR-PDP-N, 20170464-CS-REFR-PDP-N

J:\2021\0326\DWG\04sheets\PDF\13 Utility Plan.dwg, Last Saved By: Ivanover, 7/23/2021 11:35 AM, Last Printed By: Ivanover, Linda, 7/23/2021 11:50 AM
 4 Xrefs: 20170464-PDPV-1b, 20170464-CS-REFR-E, 20170464-CS-REFR-PDF-BLDG-N, 20170464-CS-REFR-PDF-PDP-N

NOTES:

①	Proposed Public Streets will be Connected to Existing Streets
②	Existing Hammerhead at Springview Lane to be Removed; as Existing Easements Allow, with Street Connection to Proposed Development
③	Future Post Road/Hyland Croy Road Improvements Shown for Reference Only

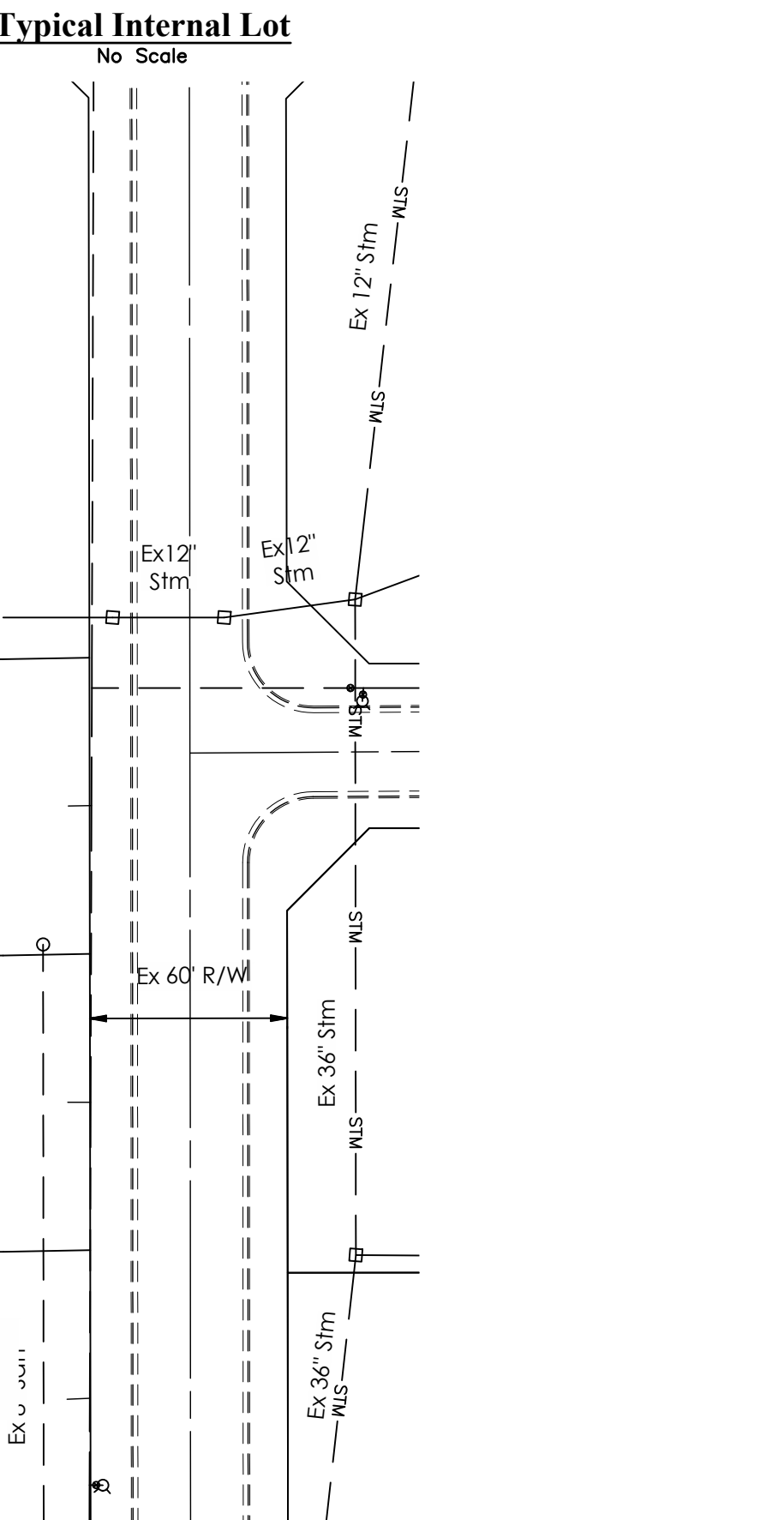
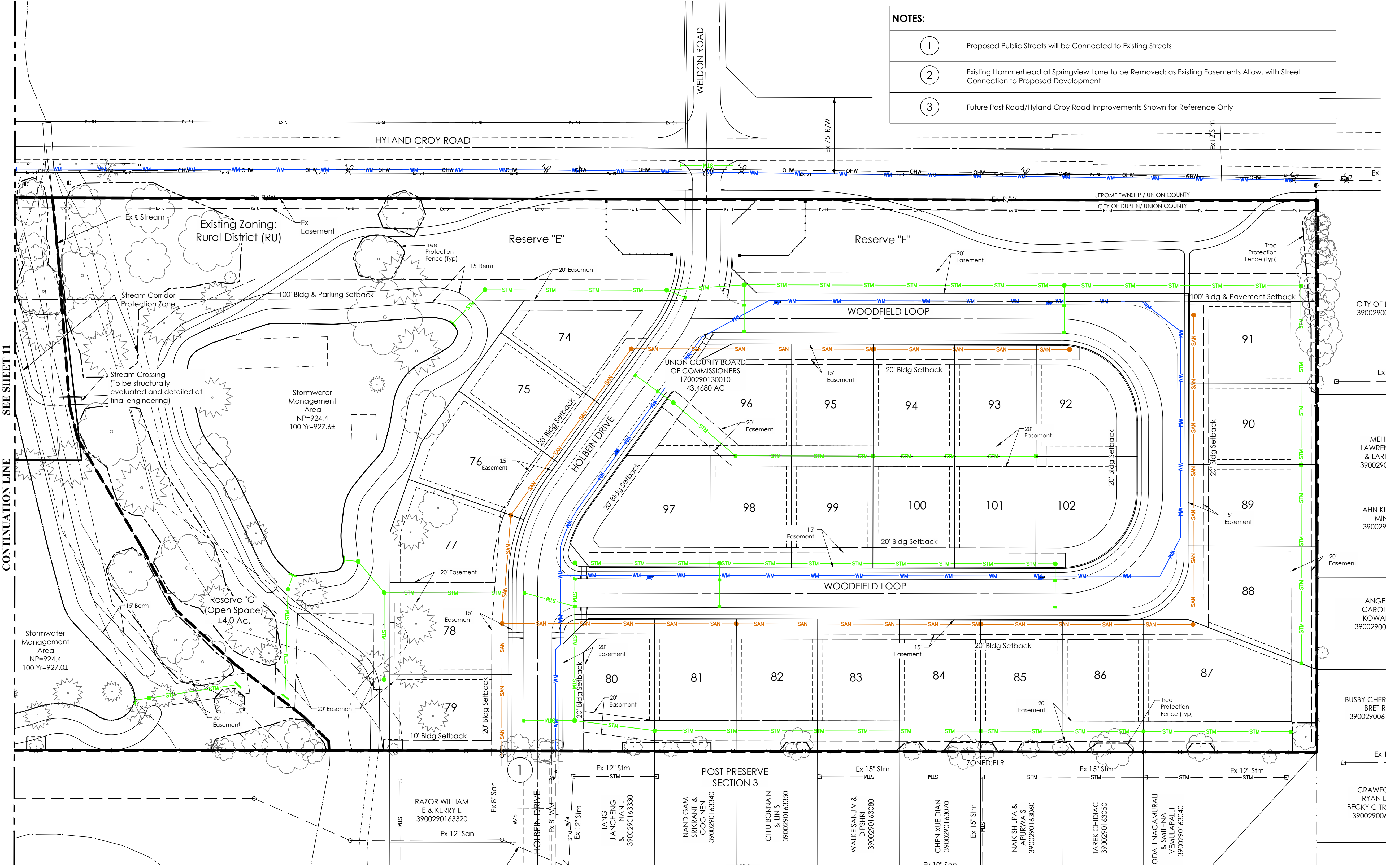
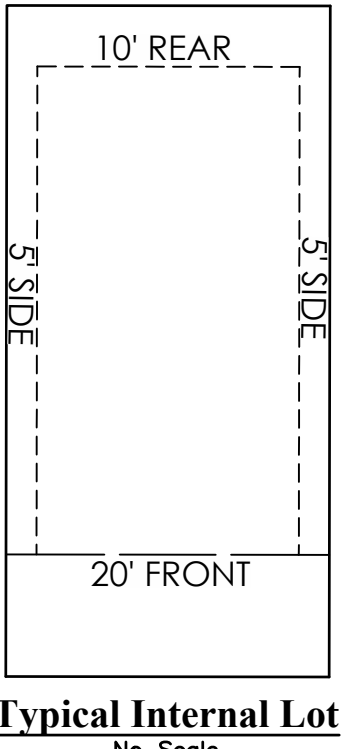

LEGEND

Existing Utilities	
STM	Storm Sewer
SAN	Sanitary Sewer
WM	Water
E	Underground Electric
C	Underground Communication
GM	Gas
UGL	Underground Street Lighting
OHW	Overhead Electric/Communication
Proposed Utilities	
STM	Storm Sewer
SAN	8" Sanitary Sewer Main
WM	Public Water Main

HYLAND GLEN

CITY OF DUBLIN, UNION COUNTY, OHIO
 PRELIMINARY DEVELOPMENT PLAN

The Paragon Building Group, LTD.
 dba Virginia Homes
 485 Metro Place South
 Suite 350
 Dublin, Ohio 43017

PREPARED BY:

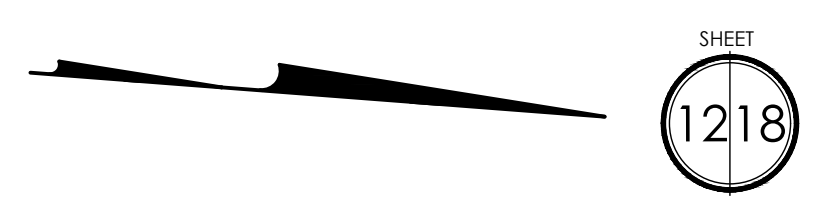
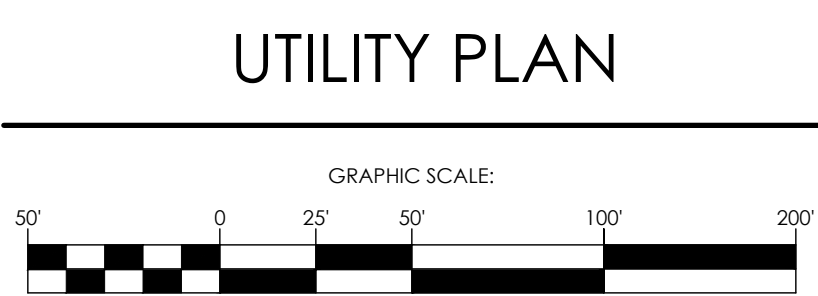

NOTES:

- ① Proposed Public Streets will be Connected to Existing Streets
- ② Existing Hammerhead at Springview Lane to be Removed; as Existing Easements Allow, with Street Connection to Proposed Development
- ③ Future Post Road/Hyland Croy Road Improvements Shown for Reference Only

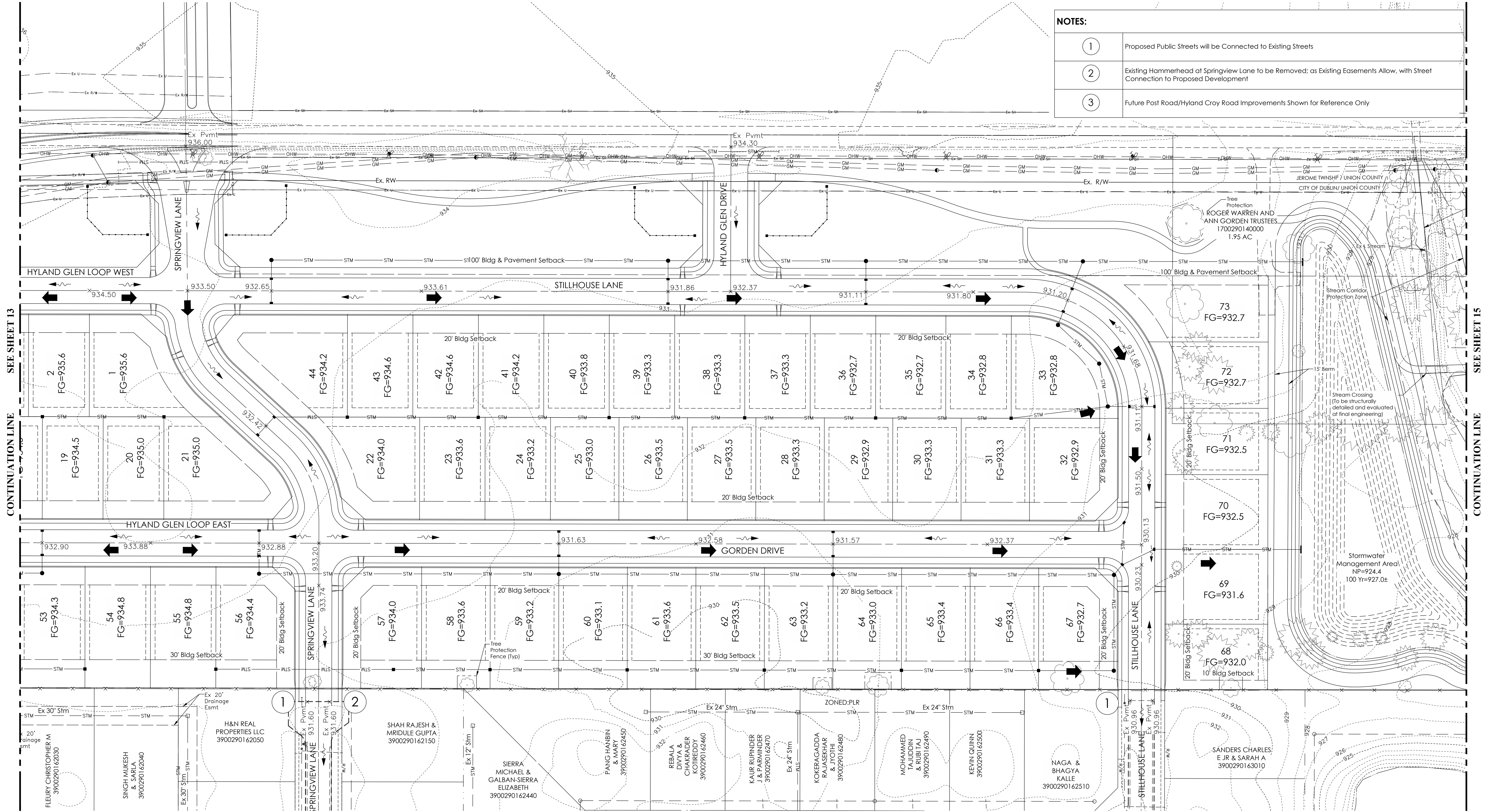

CONTINUATION LINE SEE SHEET 13

CONTINUATION LINE SEE SHEET 15

HYLAND GLEN

CITY OF DUBLIN, UNION COUNTY, OHIO
PRELIMINARY DEVELOPMENT PLAN

The Paragon Building Group, LTD.
dba Virginia Homes
485 Metro Place South
Suite 350
Dublin, Ohio 43017

PREPARED BY:



GRADING PLAN

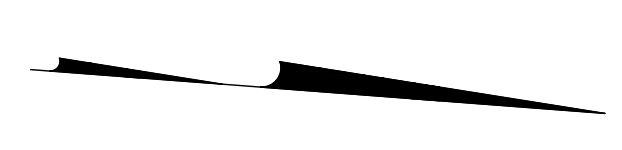
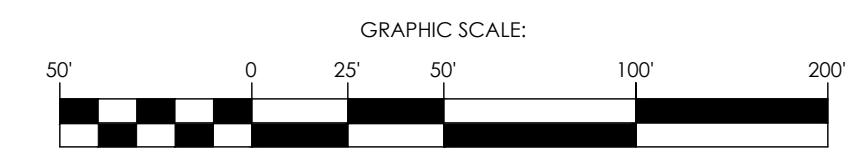

SHEET
1418

L:\2021\0326.Dwg\04\Sheets\PDF\16 Grading Plan.dwg. Last Saved By: Ivanover, 7/23/2021 11:36 AM. Last Printed By: Ivanover, 7/23/2021 11:52 AM. 4 Wre: 20170464.PDF-16_20170464-CS-REF-E_20170464-CS-REF-PDF-BLDG-N_20170464-CS-REF-PDF-N

NOTES:	
①	Proposed Public Streets will be Connected to Existing Streets
②	Existing Hammerhead at Springview Lane to be Removed, as Existing Easements Allow, with Street Connection to Proposed Development
③	Future Post Road/Hyland Croy Road Improvements Shown for Reference Only

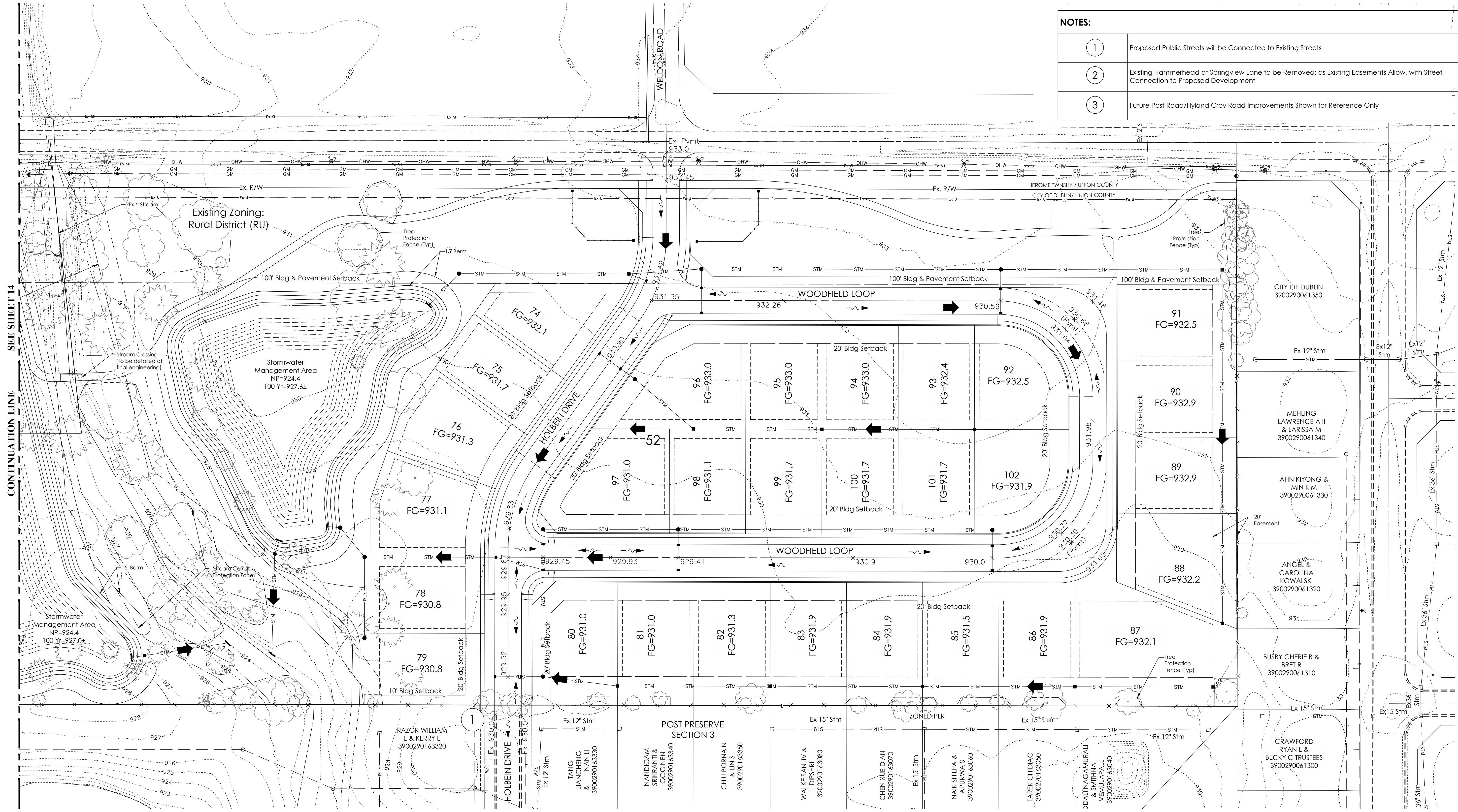

HYLAND GLEN

CITY OF DUBLIN, UNION COUNTY, OHIO
PRELIMINARY DEVELOPMENT PLAN

The Paragon Building Group, LTD.
dba Virginia Homes
485 Metro Place South
Suite 350
Dublin, Ohio 43017

PREPARED BY:

Evans, Mechwart, Hambleton & Thon, Inc.
Engineers • Surveyors • Planners • Scientists
5500 New Albany Road, Columbus, OH 43054
Phone: 614.775.4500 Fax: 614.775.4501
emht.com

GRADING PLAN

GRAPHIC SCALE:

HYLAND GLEN JULY 26, 2021 20210326

SHEET

1518

J:\2021\0326\DWG\04\sheet\PDF\16 Grading Plan.dwg, Last Saved By: Ivanover, 7/23/2021 11:36 AM, Last Printed By: Ivanover, 7/23/2021 11:53 AM
 4 Views: 20170464-FVP-1b, 20170464-CS-REF-E, 20170464-CS-REF-R, 20170464-CS-REF-PDF-N

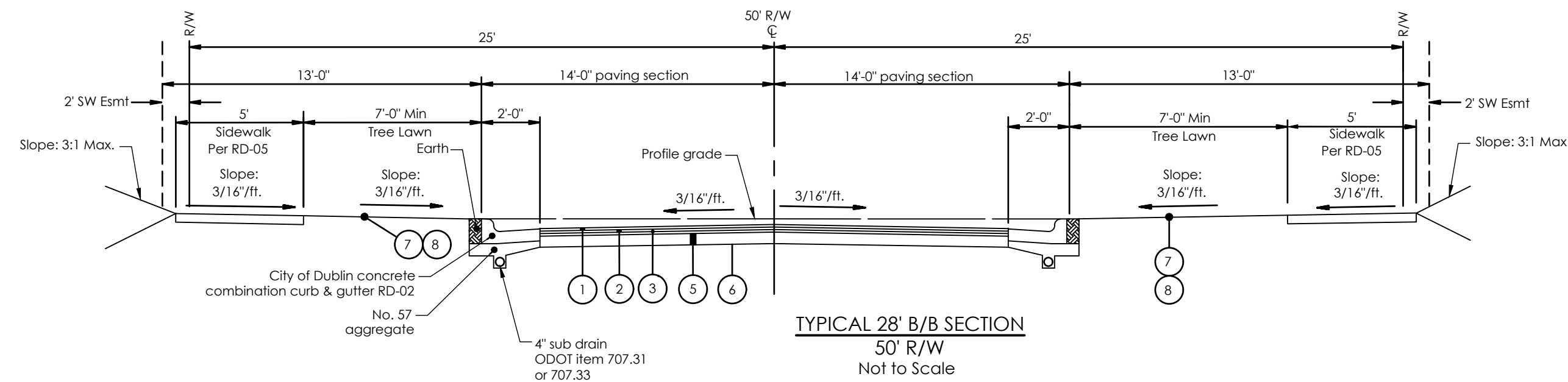

Stillhouse Lane
Hyland Glen Loop East
Hyland Glen Loop West

Springview Lane
Woodfield Loop
Gorden Drive

- PAVEMENT LEGEND**
- ① Item 448, 1.25" Asphalt Concrete, Surface Course, Type 1, Pg 64-22, Medium Traffic. *
 - ② Item 448, 1.75" Asphalt Concrete, Intermediate Course, Type 2, Pg 64-22, Medium Traffic.
 - ③ Item 301, 3" Bituminous Aggregate Base Course
 - ④ Item 301, 6" Bituminous Aggregate Base Course, (2 Courses of 3")
 - ⑤ Item 304, 6" Aggregate Base
 - ⑥ Item 204, Subgrade Compaction
 - ⑦ Item 653 - 3" Topsoil Furnished And Placed
 - ⑧ Item 659, Seeding And Mulching

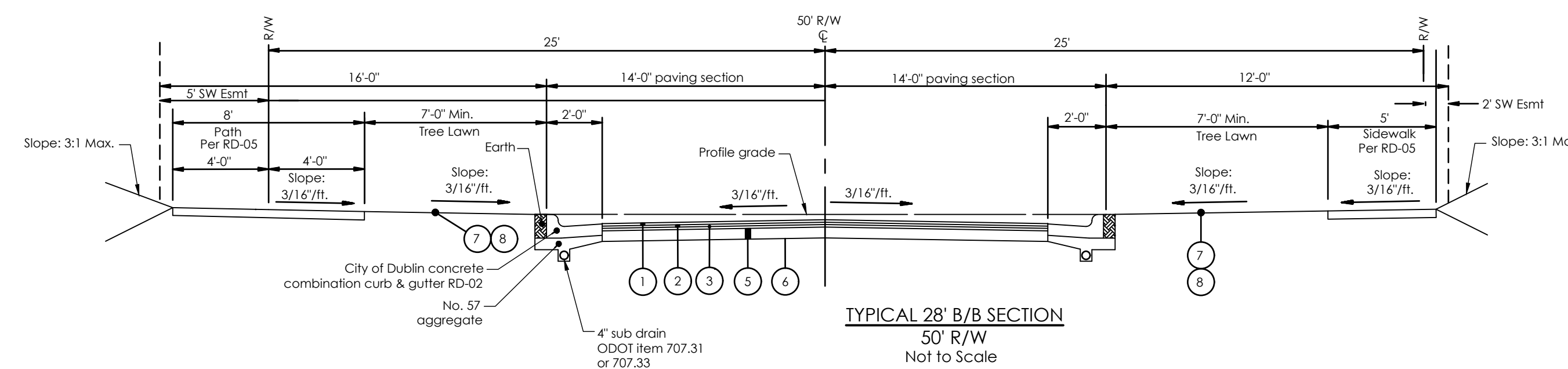

Holbein Drive

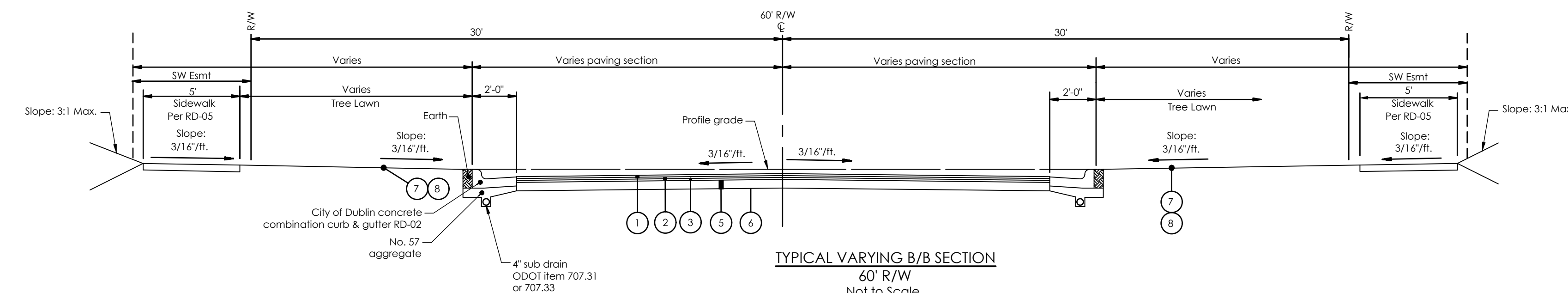
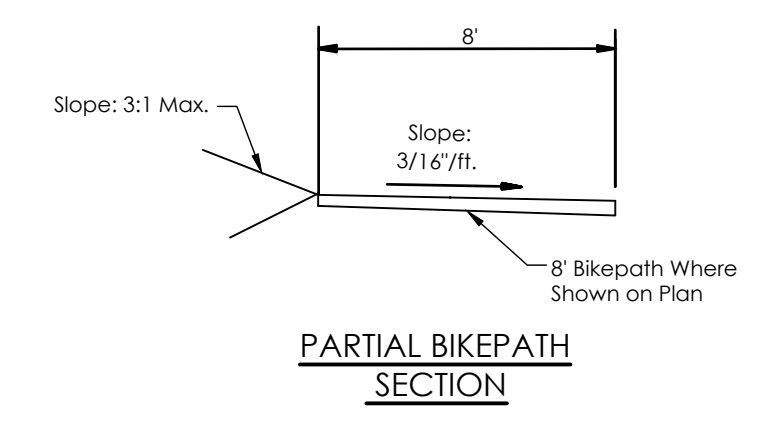

Springview Lane

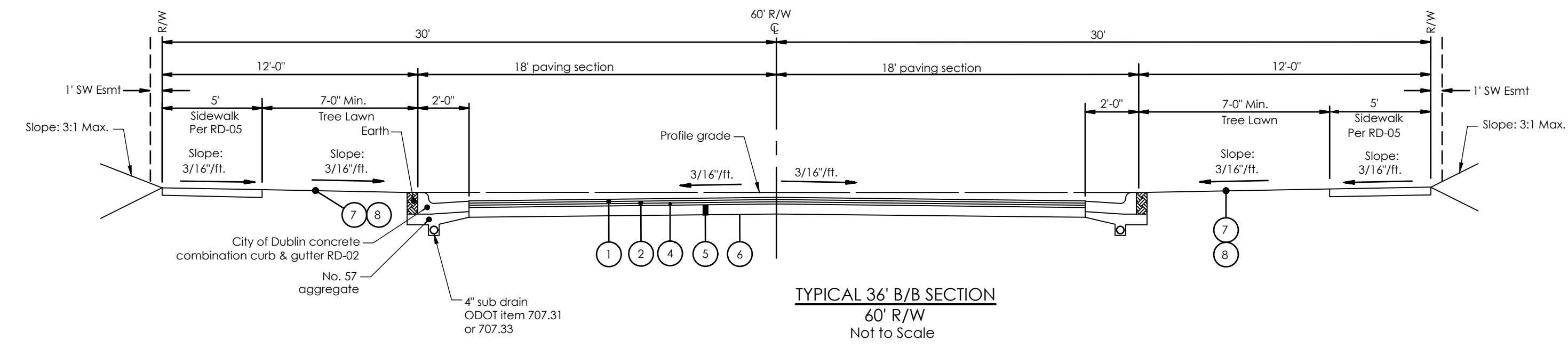

Hyland Glen Drive

HYLAND GLEN

CITY OF DUBLIN, UNION COUNTY, OHIO
PRELIMINARY DEVELOPMENT PLAN

The Paragon Building Group, LTD.
dba Virginia Homes
485 Metro Place South
Suite 350
Dublin, Ohio 43017

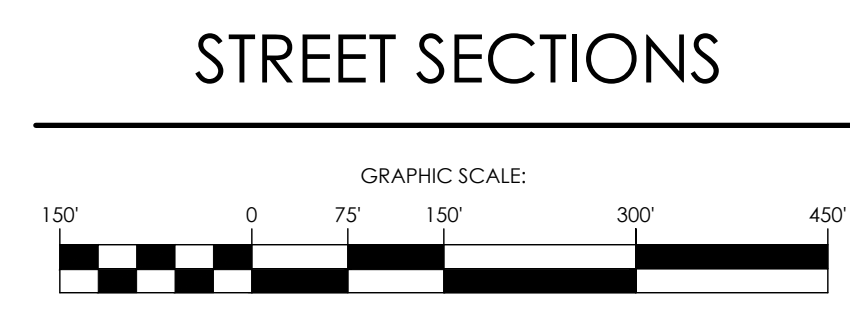

PREPARED BY:

Evans, Mechwart, Hambleton & Tilton, Inc.
Engineers • Surveyors • Planners • Scientists
5500 New Albany Road, Columbus, OH 43054
Phone: 614.775.4500 Fax: 614.775.3688
emht.com

\\cmhdad01\project\10210326\Drawings\Sheets\PDF\17 Sheet Sections.dwg, Last Saved By: Ivanover, 7/23/2021 8:51 AM, Last Printed By: Naili, Megan, 7/23/2021 12:10 PM
 4 Xrefs: 20121422-VG-TREE-NVT-E(Boulton), 20121422-CNF-FB, 20170444-PDP-FB, 20170444-CS-REFR-E

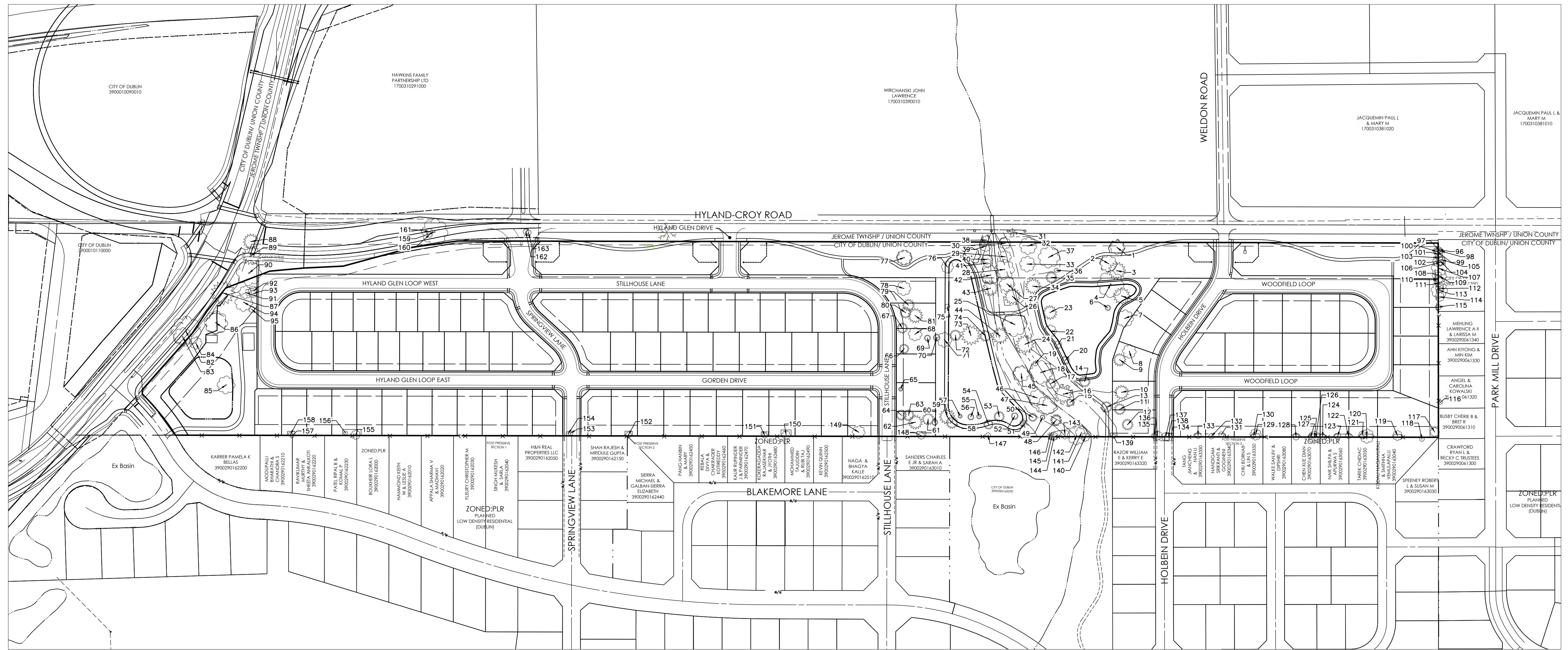

HYLAND GLEN

CITY OF DUBLIN, UNION COUNTY, OHIO

PRELIMINARY DEVELOPMENT PLAN

The Paragon Building Group, LTD.
 dba Virginia Homes
 485 Metro Place South
 Suite 350
 Dublin, Ohio 43017

PREPARED BY:



EXISTING TREE SURVEY

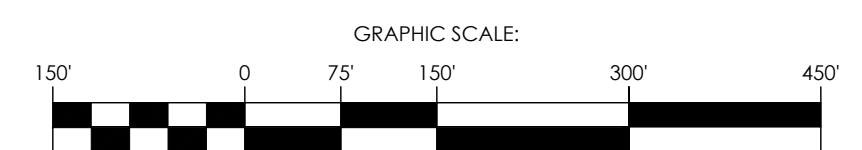

\\cmhdad01\project\1\20210326\Draw\04\sheet\PDF\18 Existing Tree Survey.dwg, Last Saved By: mmealc, 7/23/2021 2:02 PM, Last Printed By: Netici, Megan, 7/23/2021 2:03 PM
 4 Xrefs: 20121422-VG-TREE-NVT-E(Boulton), 20121422-CNF-TB, 20170444-PDVP-TB, 20170444-CS-REFR-E

#	Common Name	Scientific Name	Size (in)	Stems per Tree	Condition	Indicator	Remove Tree	Inches Removed	Inches to Replace
1	Silver Maple	Acer saccharinum	20	1	Good	Deciduous		0	0
2	Sweetgum	Liquidambar styraciflua	23	1	Fair	Deciduous		0	0
3	White Pine	Pinus strobus	25	1	Dead	Coniferous	x	25	0
4	White Ash	Fraxinus americana	37	1	Poor	Deciduous	x	37	0
5	White Pine	Pinus strobus	24	1	Fair	Coniferous	x	24	24
6	Blue Spruce	Picea pungens	8	1	Good	Coniferous	x	8	8
7	Red Maple	Acer rubrum	24	1	Fair	Deciduous	x	24	24
8	Sweetgum	Liquidambar styraciflua	19	1	Good	Deciduous	x	19	19
9	Blue Spruce	Picea pungens	18	1	Good	Coniferous	x	18	18
10	Blue Spruce	Picea pungens	20	1	Good	Coniferous	x	20	20
11	Blue Spruce	Picea pungens	16	1	Good	Coniferous	x	16	16
12	Noway Spruce	Picea abies	16	1	Good	Coniferous	x	16	16
13	Blue Spruce	Picea pungens	16	1	Poor	Coniferous	x	16	0
14	Blue Spruce	Picea pungens	16	1	Fair	Coniferous	x	16	16
15	Noway Spruce	Picea abies	10,14	2	Fair	Coniferous		0	0
16	Blue Spruce	Picea pungens	25	1	Good	Coniferous		0	0
17	Noway Spruce	Picea abies	15	1	Fair	Coniferous		0	0
18	White Ash	Fraxinus americana	33	1	Poor	Deciduous		0	0
19	Black Cherry	Prunus serotina	7	1	Fair	Deciduous		0	0
20	Blue Spruce	Picea pungens	12	1	Good	Coniferous	x	12	12
21	Red Maple	Acer rubrum	11	1	Good	Deciduous	x	11	11
22	Red Maple	Acer rubrum	17	1	Fair	Deciduous	x	17	17
23	Blue Spruce	Picea pungens	20	1	Good	Coniferous	x	20	20
24	Blue Spruce	Picea pungens	26	1	Poor	Coniferous		0	0
25	Red Maple	Acer rubrum	34	1	Fair	Deciduous		0	0
26	Blue Spruce	Picea pungens	23	1	Fair	Coniferous		0	0
27	Red Maple	Acer rubrum	22	1	Good	Deciduous		0	0
28	Red Maple	Acer rubrum	28	1	Fair	Deciduous		0	0
29	Black Locust	Robinia pseudoacacia	17	1	Good	Deciduous		0	0
30	Red Maple	Acer rubrum	16	1	Fair	Deciduous		0	0
31	White Ash	Fraxinus americana	12,10,6	3	Dead	Dead	x	28	0
32	Red Maple	Acer rubrum	24	1	Good	Deciduous		0	0
33	Red Maple	Acer rubrum	22	1	Fair	Deciduous		0	0
34	Blue Spruce	Picea pungens	22	1	Dead	Coniferous	x	22	0
35	Blue Spruce	Picea pungens	16	1	Dead	Coniferous	x	16	0
36	Red Maple	Acer rubrum	6	1	Good	Deciduous	x	6	6
37	Red Maple	Acer rubrum	30	1	Fair	Deciduous		0	0
38	Wild Crabapple	Malus coronaria	12	1	Fair	Deciduous		0	0
39	Sweetgum	Liquidambar styraciflua	16	1	Good	Deciduous		0	0
40	White Poplar	Populus alba	14,12	2	Good	Deciduous		0	0
41	Paper Birch	Betula papyrifera	12,10,8	3	Good	Deciduous		0	0
42	Bitternut Hickory	Carya cordiformis	26	1	Good	Deciduous		0	0
43	Noway Spruce	Picea abies	22	1	Fair	Coniferous		0	0
44	Blue Spruce	Picea pungens	23	1	Dead	Coniferous	x	23	0
45	Red Maple	Acer rubrum	22	1	Good	Deciduous		0	0
46	Sugar Maple	Acer saccharum	23	1	Fair	Deciduous		0	0
47	Sugar Maple	Acer saccharum	27	1	Fair	Deciduous		0	0
48	Blue Spruce	Picea pungens	15	1	Fair	Coniferous		0	0
49	Norway Spruce	Picea abies	7,7	2	Good	Coniferous		0	0
50	White Pine	Pinus strobus	12	1	Poor	Coniferous		0	0
51	White Pine	Pinus strobus	13	1	Dead	Dead	x	13	0
52	White Pine	Pinus strobus	10,6	2	Poor	Coniferous	x	16	0
53	White Pine	Pinus strobus	15	1	Poor	Coniferous	x	15	0
54	White Pine	Pinus strobus	14	1	Poor	Coniferous	x	14	0
55	Blue Spruce	Picea pungens	7	1	Good	Coniferous	x	7	7
56	Norway Spruce	Picea abies	9	1	Good	Coniferous	x	9	9
57	Blue Spruce	Picea pungens	6	1	Good	Coniferous	x	6	6
58	White Pine	Pinus strobus	17	1	Poor	Coniferous	x	17	0
59	White Pine	Pinus strobus	22	1	Fair	Coniferous	x	22	22
60	Blue Spruce	Picea pungens	9	1	Good	Coniferous	x	9	9
61	White Pine	Pinus strobus	17	1	Fair	Coniferous	x	17	17
62	White Pine	Pinus strobus	20	1	Fair	Coniferous	x	20	20
63	White Pine	Pinus strobus	16	1	Fair	Coniferous	x	16	16
64	Blue Spruce	Picea pungens	15	1	Good	Coniferous	x	15	15
65	Blue Spruce	Picea pungens	6	1	Good	Coniferous	x	6	6
66	Blue Spruce	Picea pungens	14	1	Good	Coniferous	x	14	14
67	White Pine	Pinus strobus	15	1	Good	Coniferous	x	15	15
68	Red Maple	Acer rubrum	19	1	Good	Deciduous	x	19	19
69	Blue Spruce	Picea pungens	9	1	Good	Coniferous	x	9	9
70	Blue Spruce	Picea pungens	10	1	Good	Coniferous	x	10	10
71	Red Maple	Acer rubrum	21	1	Good	Deciduous	x	21	21
72	Blue Spruce	Picea pungens	16	1	Good	Coniferous	x	16	16
73	Blue Spruce	Picea pungens	28	1	Good	Coniferous	x	28	28
74	Norway Spruce	Picea abies	16	1	Fair	Coniferous	x	16	16
75	Red Maple	Acer rubrum	7	1	Good	Deciduous	x	7	7
76	Red Maple	Acer rubrum	17	1	Fair	Deciduous	x	17	17
77	Sugar Maple	Acer saccharum	20	1	Good	Deciduous		0	0
78	Black Locust	Robinia pseudoacacia	20	1	Poor	Deciduous	x	20	0
79	Blue Spruce	Picea pungens	17	1	Good	Coniferous	x	17	17
80	Norway Spruce	Picea abies	16	1	Fair	Coniferous	x	16	16
81	Blue Spruce	Picea pungens	21	1	Fair	Coniferous		0	0
82	Tulip Tree Magnolia	Magnolia liliiflora	42	1	Fair	Deciduous		0	0
83	Red Maple	Acer rubrum	25	1	Poor	Deciduous		0	0
84	Bitternut Hickory	Carya cordiformis	17	1	Fair	Deciduous	x	17	17

#	Common Name	Scientific Name	Size (in)	Stems per Tree	Condition	Indicator	Remove Tree	Inches Removed	Inches to Replace
85	Red Oak	Quercus rubra	25	1	Good	Deciduous	x	25	25
86	Red Maple	Acer rubrum	33	1	Good	Deciduous	x	33	33
87	Norway Spruce	Picea abies	34	1	Poor	Coniferous	x	34	0
88	Virginia Pine	Pinus virginiana	22	1	Fair	Coniferous		0	0
89	Norway Spruce	Picea abies	27	1	Fair	Coniferous		0	0
90	Red Oak	Quercus rubra	35	1	Fair	Deciduous		0	0
91	Sugar Maple	Acer saccharum	18	1	Poor	Deciduous	x	18	0
92	Sugar Maple	Acer saccharum	14,7	2	Poor	Deciduous	x	14,7	0
93	Sugar Maple	Acer saccharum	11,7	2	Fair	Deciduous	x	11,7	11,7
94	Black Locust	Robinia pseudoacacia	25	1	Fair	Deciduous	x	25	25
95	Silver Maple	Acer saccharinum	9,7,9,13,9,9	6	Poor	Deciduous	x	9,7,9,13,9,9	0
96	Hackberry	Celtis occidentalis	8	1	Good	Deciduous		0	0
97	Hackberry	Celtis occidentalis	8	1	Good	Deciduous		0	0
98	Black Locust	Robinia pseudoacacia	8	1	Good	Deciduous		0	0
99	Hackberry	Celtis occidentalis	8,6	2	Good	Deciduous		0	0
100	Hackberry	Celtis occidentalis	6,6	2	Good	Deciduous		0	0
101	Hackberry	Celtis occidentalis	11	1	Good	Deciduous		0	0
102	Black Locust	Robinia pseudoacacia	15	1	Poor	Deciduous		0	0
103	Black Locust	Robinia pseudoacacia	10,10	2	Fair	Deciduous		0	0
104	Black Locust	Robinia pseudoacacia	14	1	Fair	Deciduous		0	0
105	Red Mulberry	Morus rubra	9	1	Fair	Deciduous		0	0
106	Black Locust	Robinia pseudoacacia	8	1	Good	Deciduous		0	0
107	Black Locust	Robinia pseudoacacia	22	1	Fair	Deciduous		0	0
108	Black Cherry	Prunus serotina	10	1	Poor	Deciduous		0	0
109	Black Locust	Robinia pseudoacacia	20	1	Fair	Deciduous		0	0
110	Bitternut Hickory	Carya cordiformis	13	1	Poor	Deciduous		0	0
111	Black Locust	Robinia pseudoacacia	15	1	Fair	Deciduous		0	0
112	Black Locust	Robinia pseudoacacia	12	1	Fair	Deciduous		0	0
113	Black Locust	Robinia pseudoacacia	23	1	Fair	Deciduous		0	0
114	Black Locust	Robinia pseudoacacia	13,13,10	3	Poor	Deciduous		0	0
115	Bitternut Hickory	Carya cordiformis	8	1	Good	Deciduous		0	0
116	Bitternut Hickory	Carya cordiformis	6	1	Good	Deciduous		0	0
117	Red Oak	Quercus rubra	13	1	Good	Deciduous		0	0
118	Red Maple	Acer rubrum	7	1	Good	Deciduous		0	0
119	Hackberry	Celtis occidentalis	14	1	Good	Deciduous		0	0
120	Red Maple	Acer rubrum	20	1	Good	Deciduous		0	0
121	Black Cherry	Prunus serotina	11	1	Poor	Deciduous		0	0
122	Black Cherry	Prunus serotina	8	1	Fair	Deciduous		0	0
123	Black Cherry	Prunus serotina	9	1	Good	Deciduous		0	0
124	Black Cherry	Prunus serotina	8	1	Fair	Deciduous		0	0
125	Hackberry	Celtis occidentalis	17,9,9,9	4	Good	Deciduous		0	0
126	Black Cherry	Prunus serotina	7	1	Fair	Deciduous		0	0
127	Black Cherry	Prunus serotina	6	1	Fair	Deciduous		0	0
128	Black Cherry	Prunus serotina	9	1	Fair	Deciduous		0	0
129	Hackberry	Celtis occidentalis	16	1	Good	Deciduous		0	0
130	Hackberry	Celtis occidentalis	6	1	Good	Deciduous		0	0
131	Wild Crabapple	Malus coronaria	8	1	Fair	Deciduous		0	0
132	Black Cherry	Prunus serotina	8	1	Poor	Deciduous		0	0
133	Black Cherry	Prunus serotina	9	1	Fair	Deciduous		0	0
134	Red Mulberry	Morus rubra	6,6	2	Poor	Deciduous	x	12	0
135	Black Cherry	Prunus serotina	8	1	Fair	Deciduous	x	8	8
136	Black Cherry	Prunus serotina	13	1	Poor	Deciduous	x	13	0
137	Black Cherry	Prunus serotina	12,6	2	Fair	Deciduous	x	18	18
138	Bitternut Hickory	Carya cordiformis	12,12,8,6	4	Good	Deciduous	x	38	38
139	Black Walnut	Juglans nigra	6	1	Good	Deciduous		0	0
140	Hackberry	Celtis occidentalis	12	1	Good	Deciduous		0	0
141	Black Walnut	Juglans nigra	17	1	Good	Deciduous		0	0
142	Hackberry	Celtis occidentalis	26	1	Good	Deciduous		0	0
143	Black Locust	Robinia pseudoacacia	13	1	Poor	Deciduous		0	0
144	Red Mulberry	Morus rubra	11	1	Dead	Dead	x	11	0
145	Black Locust	Robinia pseudoacacia	8	1	Dead	Dead	x	8	0
146	Black Locust	Robinia pseudoacacia	7	1	Dead	Dead	x	7	0
147	Black Cherry	Prunus serotina	7	1	Fair	Deciduous		0	0
148	Black Cherry	Prunus serotina	10	1	Fair	Deciduous		0	0
149	Red Mulberry	Morus rubra	18	1	Fair	Deciduous		0	0
150	Hackberry	Celtis occidentalis	12	1	Fair	Deciduous		0	0
151	Hackberry	Celtis occidentalis	8	1	Fair	Deciduous		0	0
152	Black Cherry	Prunus serotina	8	1	Poor	Deciduous		0	0
153	Red Mulberry	Morus rubra	7	1	Fair	Deciduous	x	7	7
154	Black Cherry	Prunus serotina	7	1	Poor	Deciduous	x	7	0
155	Hackberry	Celtis occidentalis	13	1	Good	Deciduous		0	0
156	Wild Crabapple	Malus coronaria	6	1	Poor	Deciduous		0	0
157	Hackberry	Celtis occidentalis	6	1	Good	Deciduous		0	0
158	Black Cherry	Prunus serotina	6	1	Good	Deciduous		0	0
159	Red Mulberry	Morus rubra	37,19,13,10	4	Poor	Deciduous		0	0
160	Red Mulberry	Morus rubra	8,8,8	3	Fair	Deciduous		0	0
161	Red Mulberry	Morus rubra	9	1	Poor	Deciduous		0	0
162	Hackberry	Celtis occidentalis	8,7	2	Poor	Deciduous		0	0
163	Red Mulberry	Morus rubra	8,8,8,6	4	Poor	Deciduous		0	0
164	White Ash	Fraxinus americana	28	1	Dead	Dead	x	28	0

LEGEND

Dead Trees