

PRELIMINARY   
ONLY FOR REVIEW BY HOME OWNER.  
NOT THE FINISHED PRODUCT.

ESTIMATING   
COMPARE PRICES FOR CONSTRUCTION

CONSTRUCTION   
FOR BUILDING PURPOSES

Lyons Residence  
Est. 2021

© COPYRIGHT 2020  
ALL DRAWINGS ARE AND SHALL REMAIN  
THE PROPERTY OF CHATEAUX DESIGNS  
AND MAY NOT BE USED, DUPLICATED  
OR ALTERED WITHOUT THE WRITTEN  
CONSENT OF CHATEAUX DESIGNS

DISCLAIMER NOTE:  
WHOM EVER USES THESE PLANS  
AGREE TO THE FOLLOWING:  
CHATEAUX DESIGNS WILL NOT  
ASSUME LIABILITY FOR ANY DAMAGES  
DUE TO ERRORS, OMISSIONS,  
OR DEFICIENCIES ON THESE PLANS.  
OWNER OR BUILDER MUST COMPLY  
WITH ALL LOCAL BUILDING CODE PRIOR  
TO COMMENCEMENT OF ANY WORK.  
DATE: 9-29-2021  
REVISED:



**FRONT ELEVATION**

1/4" = 1'-0"

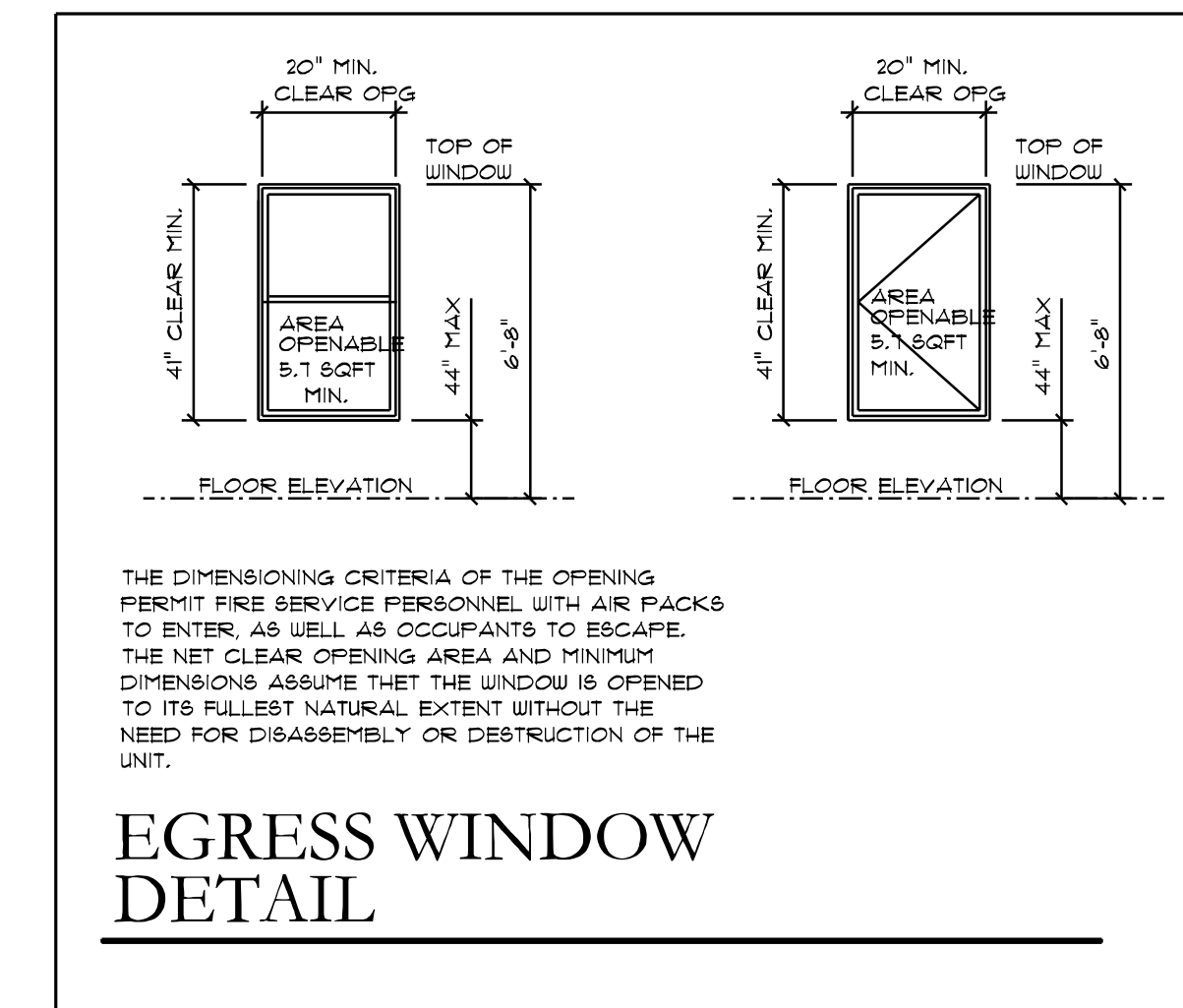
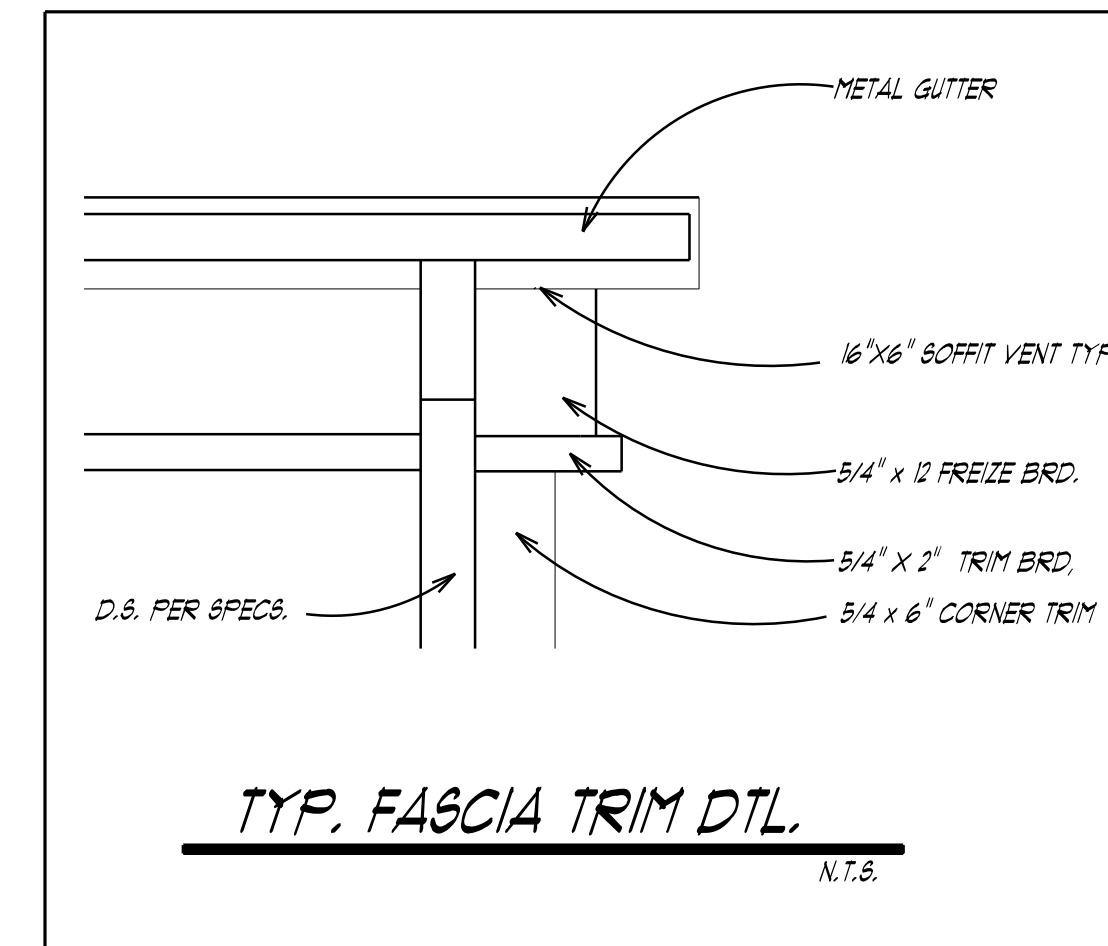
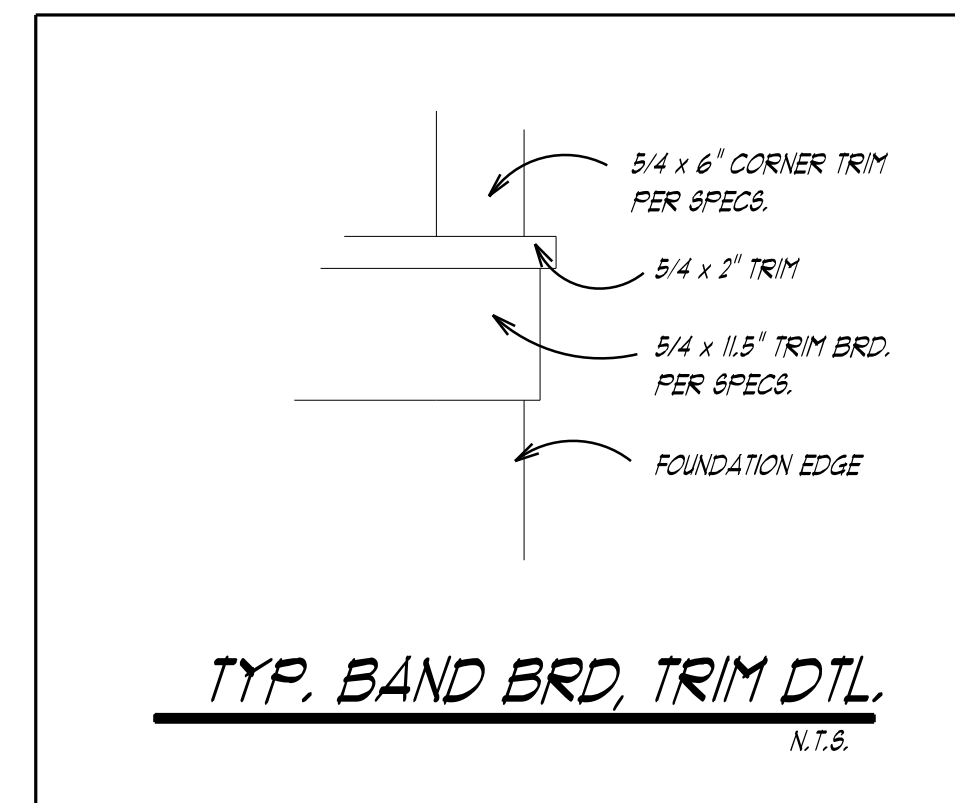
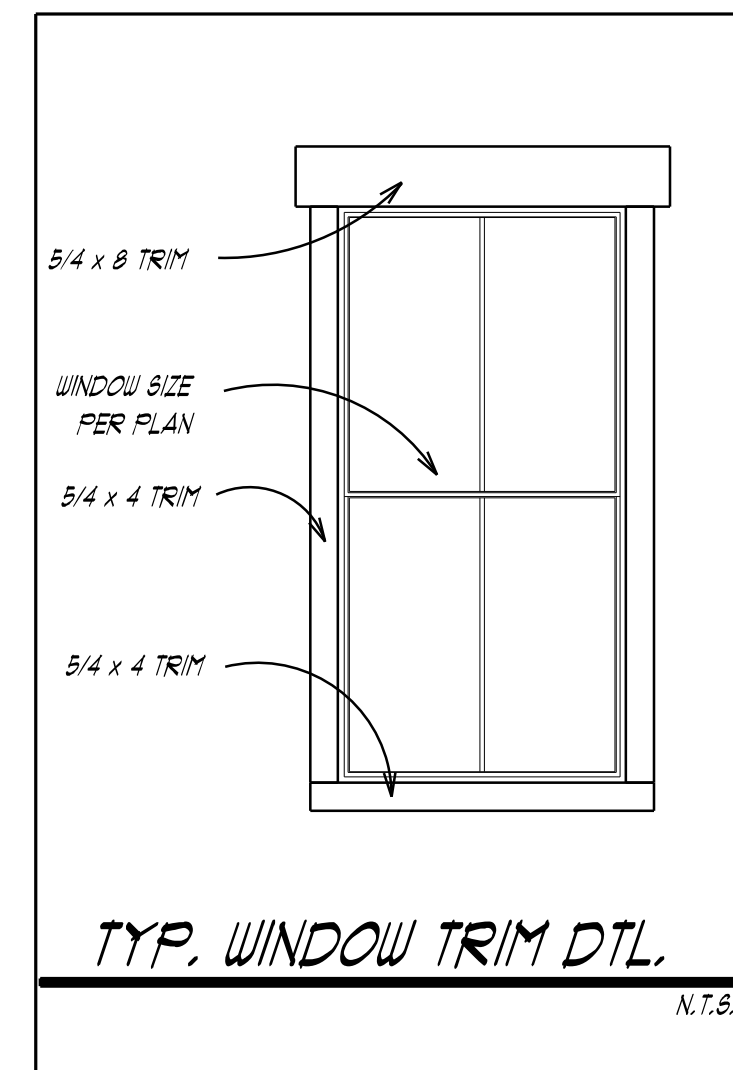

**EXTERIOR ELEVATION LEGEND:**

	30 YR. DIMENSIONAL ASPHALT SHINGLES ( PER SPEC )
	BOARD AND BATON PER. SPECS
	VINYL SHAKE SIDING
	STANDING SEAM METAL ROOF
EXTERIOR TRIM:	5/4x6" TOP & BOTTOM 5/4" x 3.5" SIDES PER SPECS
FASCIA:	1x6 ALUM
GUTTER:	5" OGEE ALUM
SOFFIT:	VINYL ( VENTED )
PORCH POST:	SEE FLOOR PLAN FOR SIZE
RIDGE VENT:	CONT.
WINDOW TYPE:	PER SPECS ( SIZES PER FLOOR PLANS )
WINDOW TRIM:	5/4 x 6 TRIM TOP ( PER SPECS. ) 5/4 x 4 TRIM SIDES ( PER SPECS )

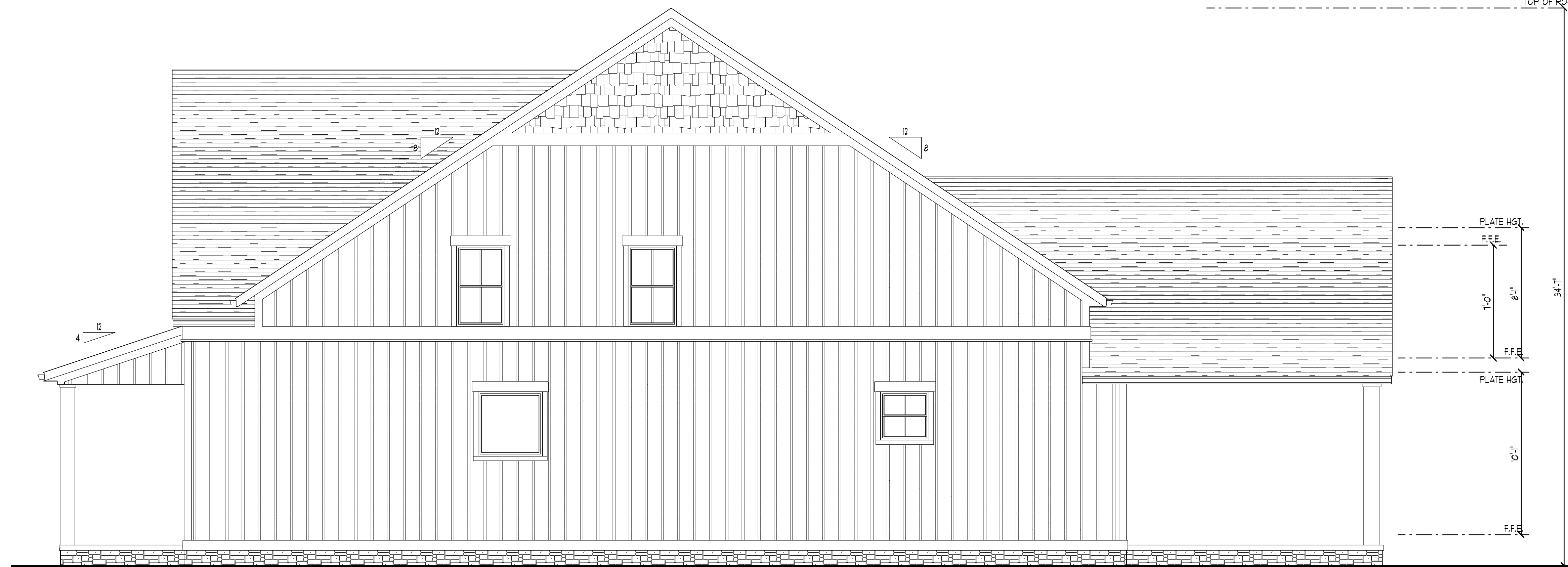





**RIGHT ELEVATION**

1/4" = 1'-0"

PRELIMINARY   
ONLY FOR REVIEW BY HOME OWNER.  
NOT THE FINISHED PRODUCT

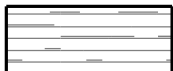
ESTIMATING   
COMPARE PRICES FOR CONSTRUCTION

CONSTRUCTION   
FOR BUILDING PURPOSES

EXTERIOR ELEVATION LEGDEN:	
	30 YR. DIMENSIONAL ASPHALT SHINGLES ( PER SPEC )
	BOARD AND BATON PER. SPECS
	VINYL SHAKE SIDING
	STANDING BEAM METAL ROOF
EXTERIOR TRIM:	5/4"x6" TOP & BOTTOM 5/4" x 3.5" SIDES PER SPECS
FASCIA:	1x6 ALUM
GUTTER:	5" OGEE ALUM
SOFFIT:	VINYL ( VENTED )
PORCH POST:	SEE FLOOR PLAN FOR SIZE
RIDGE VENT:	CONT.
WINDOW TYPE:	PER SPECS ( SIZES PER FLOOR PLANS )
WINDOW TRIM:	5/4" x 6" TRIM TOP ( PER SPECS. ) 5/4" x 4" TRIM SIDES ( PER SPECS. )



LEFT ELEVATION

1/4" = 1'-0"

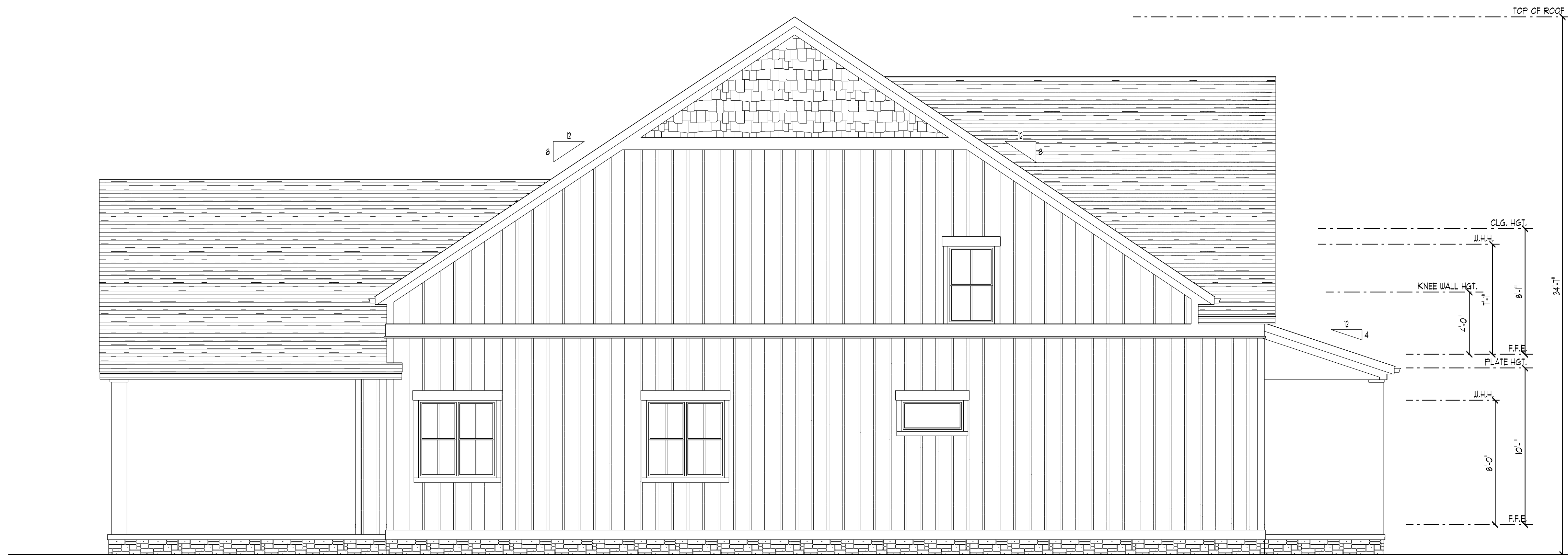

REAR ELEVATION

1/4" = 1'-0"

Lyons Residence  
Est. 2021

© COPYRIGHT 2020  
ALL DRAWINGS ARE AND SHALL REMAIN  
THE PROPERTY OF CHATEAUX DESIGNS  
AND MAY NOT BE USED, DUPLICATED  
OR ALTERED WITHOUT THE WRITTEN  
CONSENT OF CHATEAUX DESIGNS

DISCLAIMER NOTE:  
WHOM EVER USES THESE PLANS  
AGREE TO THE FOLLOWING:  
CHATEAUX DESIGNS WILL NOT  
ASSUME LIABILITY FOR ANY DAMAGES  
DUE TO ERRORS, OMISSIONS,  
OR DEFICIENCIES ON THESE PLANS.  
OWNER OR BUILDER MUST COMPLY  
WITH ALL LOCAL BUILDING CODE PRIOR  
TO COMMENCEMENT OF ANY WORK.  
DATE: 9-29-2021  
REVISED: