

NEUROLOGICAL TRANSITIONAL CENTER

DUBLIN, OH

CONDITIONAL USE PERMIT DRAWINGS - NOT FOR CONSTRUCTION

SEPTEMBER 14, 2022



GWG³
ARCHITECTURE, PLLC

600 Main Street
Suite 300
North Little Rock, AR 72114
Phone: 501-758-7443

www.taggarch.com

CONDITIONAL USE
PERMIT DRAWINGS -
NOT FOR
CONSTRUCTION



NEUROLOGICAL
TRANSITIONAL
CENTER

DUBLIN, OH

PROJECT NAME

INDEX OF DRAWINGS

GENERAL

- G0.1 - COVER PAGE
- G0.2 - EXTERIOR VIEWS

CIVIL

- C0.1 - TITLE SHEET
- C0.2 - GENERAL NOTES General Notes
- C0.3 - LEGEND
- C0.4 - DETAILS
- C0.5 - EXISTING CONDITIONS AND DEMOLITION PLAN
- C0.6 - SITE AND DIMENSION PLAN
- C0.7 - UTILITY PLAN
- C0.8 - EROSION SEDIMENT CONTROL NOTES & DETAILS
- C0.9 - EROSION SEDIMENT CONTROL PLAN
- C1.0 - STORM PROFILES
- C1.1 - BASIN DETAILS
- C1.2 - WATER SERVICE PLAN TITLE SHEET
- C1.3 - WATER SERVICE PLAN & PROFILE

LANDSCAPE

- L0.1 - LANDSCAPE PLAN
- L0.2 - LANDSCAPE DETAILS AND NOTES

ELECTRICAL

- E101 - ELECTRICAL SITE PLAN
- E102 - SITE PLAN PHOTOMETRICS

ARCHITECTURAL

- A1.0 - FLOOR PLAN
- A1.1 - ROOF PLAN
- A2.0 - EXTERIOR ELEVATIONS

LOCATION MAP - NOT TO SCALE

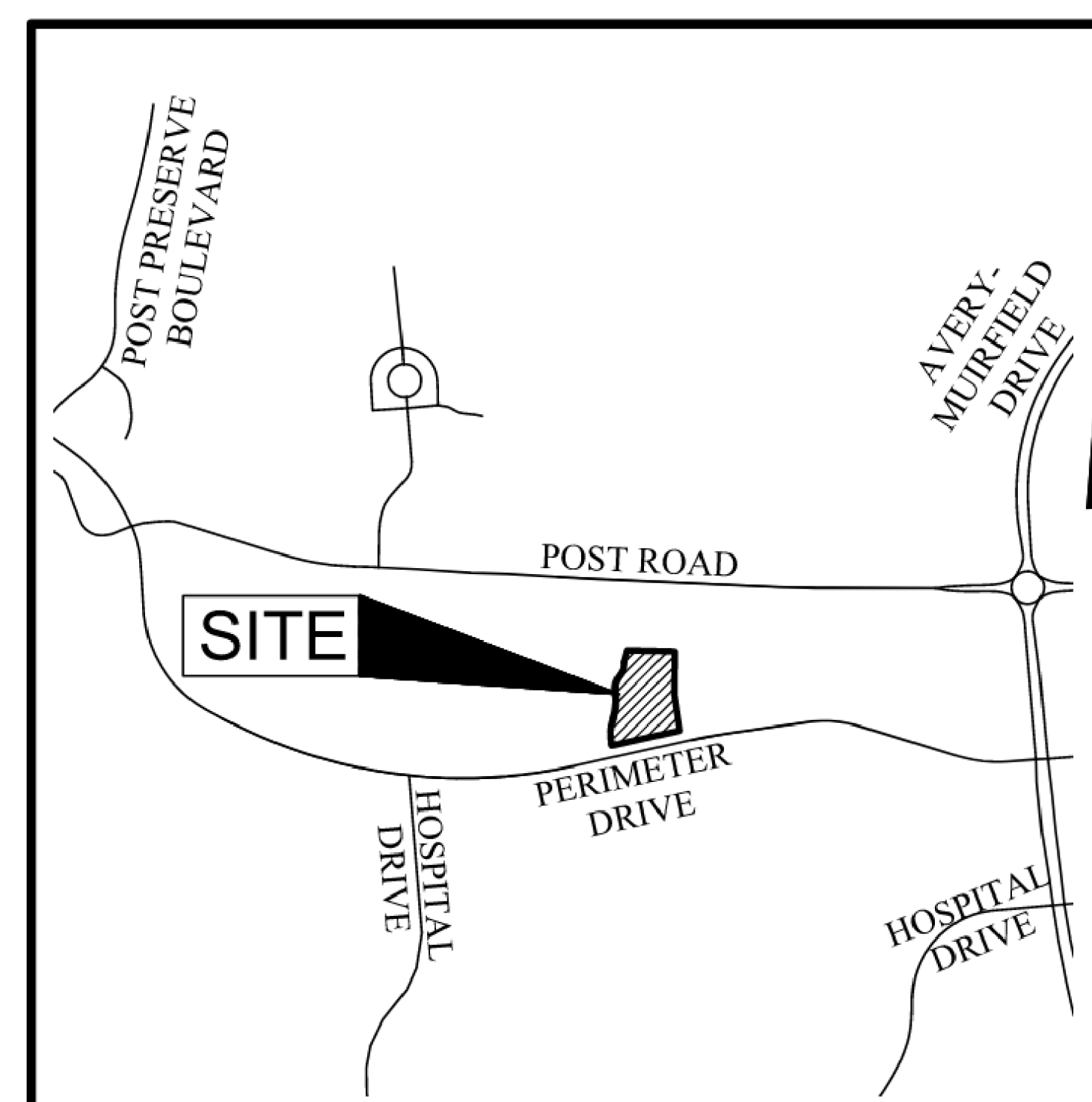

GWG3 ARCHITECTURE, PLLC

600 Main Street, Suite 300
North Little Rock, AR 72114
501-758-7443
taggarch.com

MEPF ENGINEER
HPMB CONSULTING ENGINEERS
2828 E. Trinity Mills Road, Ste 210
Carrollton, TX 75006
Telephone: (214)483-6202
www.hpmbengineers.com

CIVIL ENGINEER
**EMH&T - EVANS, MECHWART,
HAMBLETON & TILTON, INC.**
5500 New Albany Road
Columbus, OH 43054
Phone: (614)775-4500
www.emht.com

STRUCTURAL ENGINEER
ROBBINS ENGINEERING, PLLC
10018 West Markham
Little Rock, AR 72205
Office: 501-664-7575
www.robbins-engineering.com

SEAL

REVISIONS

NO.	DESCRIPTION	DATE
1		

COVER SHEET

SHEET NAME

DATE SEPTEMBER 14, 2022

PROJECT NUMBER 149821

SHEET NUMBER

G0.1



NORHTEAST VIEW
(VIEW FROM ENTRY DRIVE)

GWG³
ARCHITECTURE, PLLC

600 Main Street
Suite 300
North Little Rock, AR 72114
Phone: 501-758-7443

www.taggarch.com

CONDITIONAL USE
PERMIT DRAWINGS -
NOT FOR
CONSTRUCTION



NORH VIEW
(VIEW FROM PARKING DRIVE)



SOUTHEAST VIEW
(VIEW FROM PERIMETER DRIVE)



NEUROLOGICAL
TRANSITIONAL
CENTER

DUBLIN, OH

PROJECT NAME



NORHTEAST VIEW
(OVERHEAD VIEW)



SOUTHEAST VIEW
(OVERHEAD VIEW)

SEAL

REVISIONS

NO.	DESCRIPTION	DATE

EXTERIOR VIEWS

SHEET NAME

DATE SEPTEMBER 23, 2022

PROJECT NUMBER 149821

SHEET NUMBER **G1.1**

CITY OF DUBLIN, FRANKLIN COUNTY, OHIO
FINAL DEVELOPMENT PLAN
 FOR
NEUROLOGICAL
TRANSITIONAL CENTER
 2022

SHEET INDEX

Title Sheet	C0.1
General Notes	C0.2
Legend	C0.3
Details	C0.4
Existing Conditions and Demolition Plan	C0.5
Site and Dimension Plan	C0.6
Utility Plan	C0.7
Erosion Sediment Control Notes & Details	C0.8
Erosion Sediment Control Plan	C0.9
Storm Profiles	C1.0
Basin Details	C1.1
Water Service Plan Title Sheet	C1.2
Water Service Plan & Profile	C1.3
Landscape Plan	L0.1
Landscape Details & Notes	L0.2

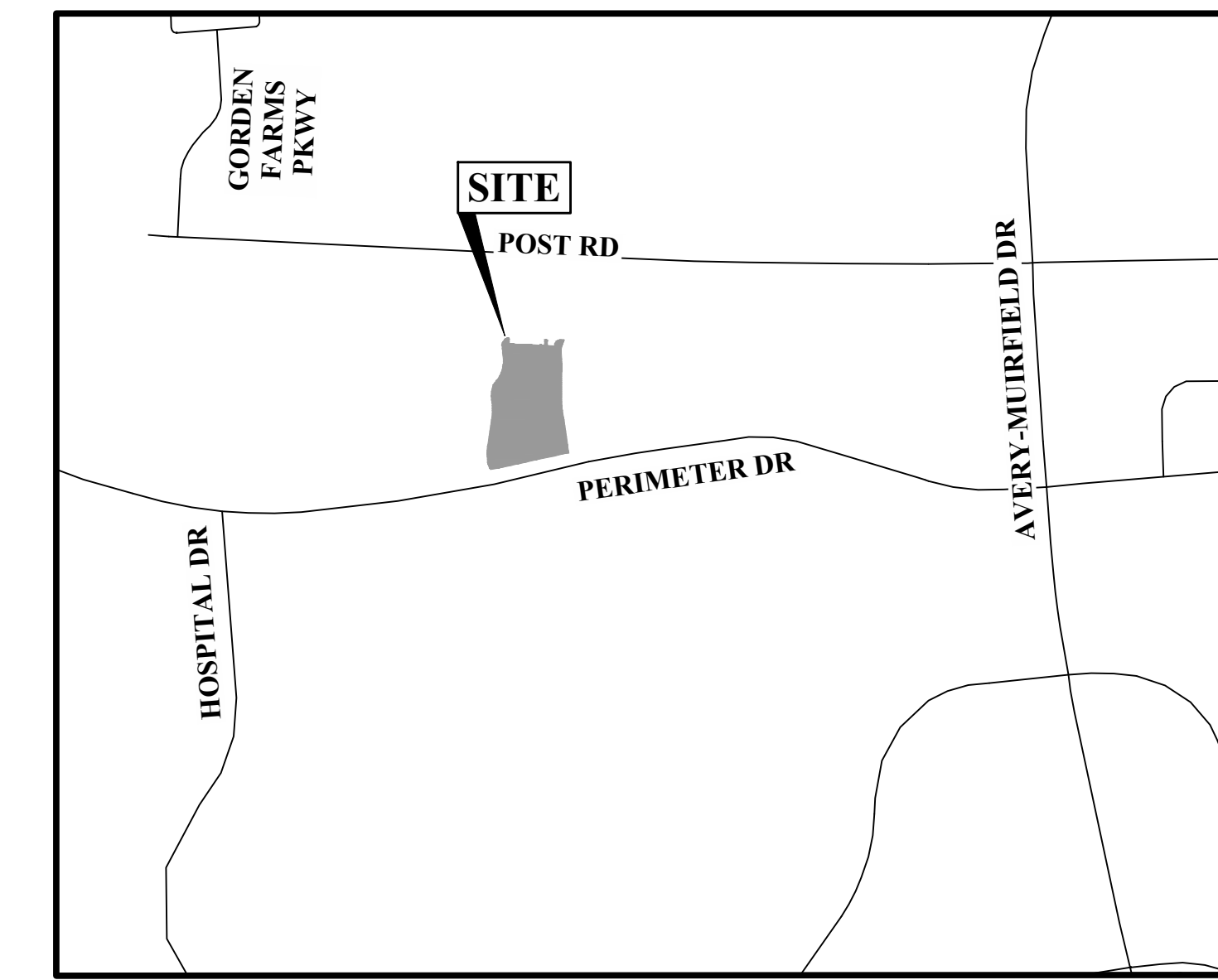

LOCATION MAP
Scale: 1" = 500'

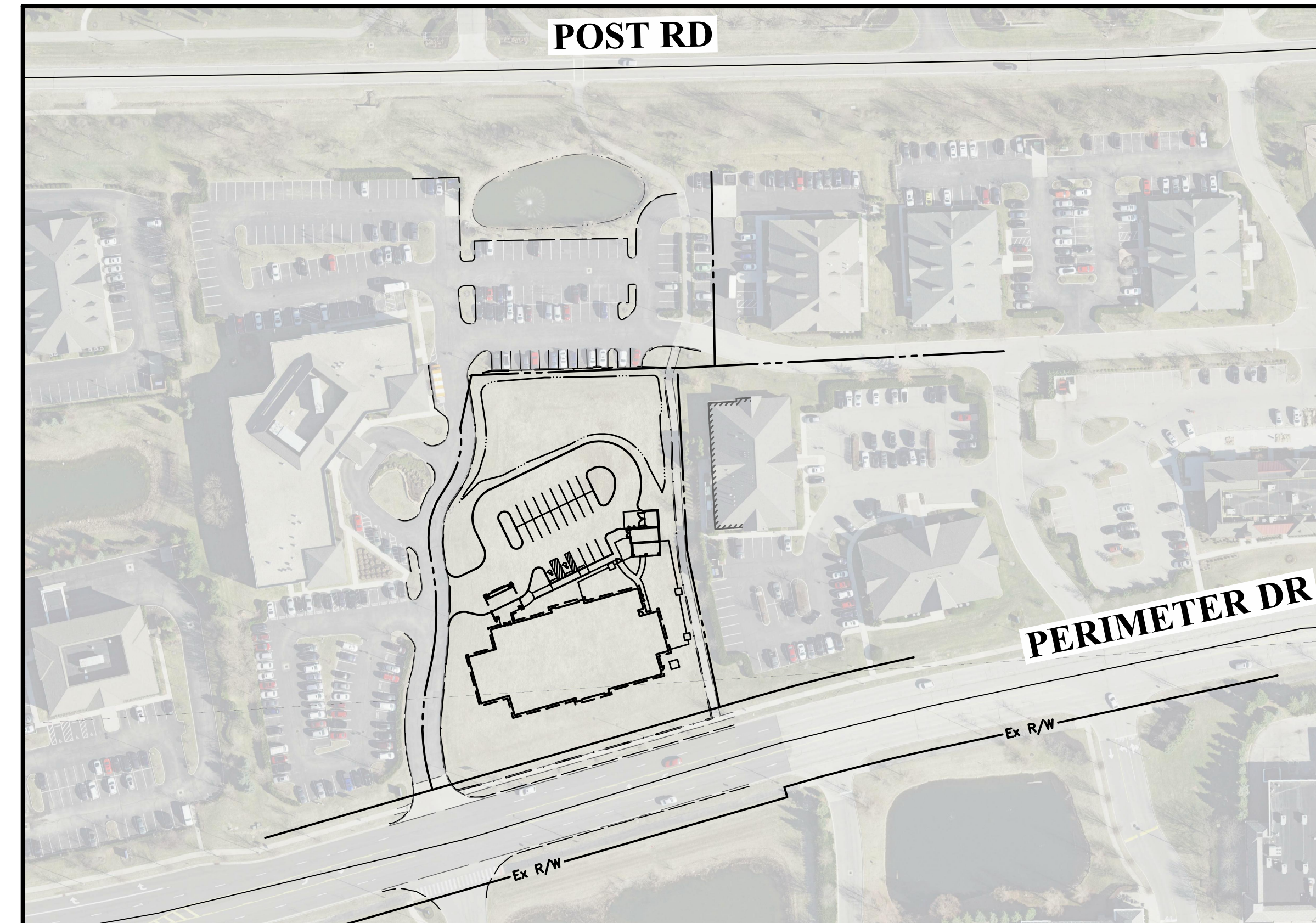

INDEX MAP
Scale: 1" = 100'

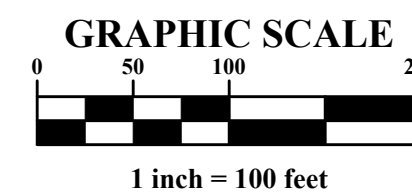

SITE DATA

Site is zoned PCD Riverside North Planned Commerce District.

PROPERTY COVERAGE SUMMARY

Total Area (Acres):	1.99
Building:	0.32
Sidewalk:	0.06
Pavement:	0.58
Percent Impervious Proposed/Provided:	48%
Maximum Lot Coverage Allowed (Per Zoning):	70%

FEMA NOTE

According to the Federal Emergency Management Agency's Flood Insurance Rate Map (dated June 17, 2008), the subject parcel shown hereon lie within Zone "X", Community Panel No. 131k.

DEVELOPER/OWNER

Select Medical
 Nick Belfer
 4714 Gettysburg Road
 Mechanicsburg, PA 17055
 Tel: (717) 215-4411
 Email: NBelfer@selectmedical.com

ENGINEER

EMH&T INC.
 Joe Walker, PE
 5500 New Albany Rd
 Columbus, Ohio 43054
 Tel: (614) 775-4629
 Email: jwalker@emht.com

SURVEYOR

EMH&T INC.
 Heather King, PS
 5500 New Albany Rd
 Columbus, Ohio 43054
 Tel: (614) 775-4120
 Email: hking@emht.com
 Date of Survey: April 30, 2022



MUNICIPALITY APPROVAL

Signature below signify only concurrence with the General Purposes and general location of the Project and does not constitute assurance to operate as intended. All technical Details remain the responsibility of the professional Civil engineer preparing the plans.

 Paul A. Hammersmith, P.E.
 Director of Engineering/City of Engineer

 Jennifer M. Rauch, AICP
 Director of Planning, City of Dublin, Ohio

PREPARED BY:



Registered Engineer No. 80173
 (Please Reference Engineer's Contact Information Above)

_____ Date



600 Main Street
 Suite 300
 North Little Rock, AR 72114
 Phone: 501-758-7443

www.taggarch.com

FINAL
 DEVELOPMENT PLAN
 NOT FOR
 CONSTRUCTION



NEUROLOGICAL
 TRANSITIONAL
 CENTER

DUBLIN, OH

PROJECT NAME _____

SEAL _____

REVISIONS _____

NO.	DESCRIPTION	DATE

TITLE SHEET

SHEET NAME _____

DATE October 19, 2022

PROJECT NUMBER 20220237

SHEET NUMBER **C0.1**

PRELIMINARY
 NOT TO BE USED FOR
 CONSTRUCTION

PLAN SET DATE
 October 19, 2022

\\cmidat001\project01\20220237\Draw\04Sheets\Plan Set\Title Sheet.dwg, Last Saved By: pschoeffer, 10/19/2022 9:59 AM Last Printed By: Walker, Joe, 10/19/2022 3:12 PM (No Xrefs)

GENERAL NOTES

- City of Columbus and Ohio Department of Transportation Construction and Material Specifications, current editions, and any supplements thereto (hereafter referred to as Standard Specifications), shall govern all construction items unless otherwise noted. If a conflict between specifications is found, the more strict specification will apply as decided by the City Engineer. Item Numbers listed refer to City of Columbus Item Numbers unless otherwise noted.
- The City Engineer will not be responsible for means, methods, procedures, techniques, or sequences of construction that are not specified herein. The City Engineer will not be responsible for safety on the work site, or for failure by the Contractor to perform work according to contract documents.
- The Developer or Contractor shall be responsible to obtain all necessary permits including but not limited to Ohio EPA Permits to Install (PTI) and Notices of Intent (NOI), Building Permits, etc.
- The Contractor shall notify the City of Dublin Division of Engineering in writing at least 3 working days prior to beginning construction.
- The Contractor shall be solely responsible for complying with all federal, state and local safety requirements including the Occupational Safety and Health Act of 1970. The Contractor shall exercise precaution always for the protection of employees (including employees) and property. It shall also be the sole responsibility of the Contractor to initiate, maintain and supervise all safety requirements, precautions and programs in connection with the work, including the requirements for confined spaces per 29 CFR 1910.146.
- Following completion of construction of the site improvements and before requesting occupancy, a proof survey shall be provided to the Division of Engineering that documents "as-built" elevations, dimensions, slopes and alignments of all elements of this project. The proof survey shall be prepared, signed and submitted by the Professional Engineer who sealed the construction drawings.
- The Contractor shall restrict construction activity to public right-of-way and areas defined as permanent on-/or temporary construction easements, unless otherwise authorized by the City Engineer.
- The Contractor shall carefully preserve bench marks, property corners, reference points, stakes and other survey reference monuments or markers. In case of willful or careless destruction, the Contractor shall be responsible for restorations. Resetting of markers shall be performed by an Ohio Professional Surveyor as approved by the City Engineer.
- Non-rubber tired vehicles shall not be moved on or across public streets or highways without the written permission of the City Engineer.
- The Contractor shall restore all disturbed areas to equal or better condition than existed before construction. Drainage ditches or water courses that are disturbed by construction shall be restored to the grades and cross-sections that existed before construction.
- Tracking or spilling mud, dirt or debris upon streets, residential or commercial drives, sidewalks or bike paths is prohibited under Section 97.38 of the Dublin Code of Ordinances. Any such occurrence shall be cleaned up immediately by the Contractor at no cost to the City. If the Contractor fails to remove silt, mud, dirt, debris, or spillage, the City reserves the right to remove these materials and clean affected areas, the cost of which shall be the responsibility of the Contractor.
- Disposal of excess excavation within Special Flood Hazard Areas (100-year floodplain) is not permitted.
- All signs, landscaping, structures or other appurtenances within right-of-way disturbed or damaged during construction shall be replaced or repaired to the satisfaction of the City Engineer. The cost of this work shall be the responsibility of the Contractor.
- All field tile broken or encountered during excavation shall be replaced or repaired and connected to the public storm sewer system as directed by the City Engineer. The cost of this work shall be the responsibility of the Contractor.
- All precast concrete products shall be inspected at the location of manufacture. Approved precast concrete products will be stamped or have such identification noting that inspection has been conducted by the City of Columbus. Precast concrete products without proof of inspection shall not be approved for installation.
- Backfill within a 1:1 influence line of existing structures (houses, garages, etc.) or public infrastructure (pavement, curbs, sidewalks, bike paths, etc.) shall be compacted granular backfill according to item 912 of the Standard Specifications or Flowable CDF, Type II according to item 613. Item 911 of the Standard Specifications may be used elsewhere.
- The Contractor shall submit a copy of the approved construction drawings and a list of proposed precast concrete product manufacturers to the City of Columbus Construction Inspection Division before commencing construction.

Send the information to the following address:
Construction Inspection Division
City of Columbus
1800 East 17th Avenue
Columbus, Ohio 43219

Send a copy of the transmittal letter to the following address:
Division of Engineering
City of Dublin
6555 Shier Rings Road
Dublin, Ohio 43016

- All trenches within public right-of-way shall be backfilled according to the approved construction drawings or securely plated during nonworking hours. Trenches outside these areas shall be backfilled or shall be protected by approved temporary fencing or barricades during nonworking hours. Clean-up shall follow closely behind the trenching operation.
- All trees within the construction area not specifically designated for removal shall be preserved, whether shown or not shown on the approved construction drawings. Trees to be preserved shall be protected with high visibility fencing placed a minimum 15 feet from the tree trunk. Trees 6 inches or greater at DBH (Diameter Breast Height) must be protected with fencing placed at the critical root zone or 15 feet, whichever is greater, on the approved construction drawings for removal may not be removed without prior approval of the Division of Engineering.
- Conduit must be directionally bored across streets instead of open cut, unless specifically approved by the City Engineer. Use of pneumatic air ram devices is not permitted. Permits to construct in the right-of-way of existing streets must be obtained from the City of Dublin Division of Engineering before commencing construction. Should open cutting of existing pavement be permitted, Controlled Density Backfill (Type II) shall be used in place of compacted granular backfill, according to item 613 of the Standard Specifications.
- The Contractor shall be responsible for the condition of trenches within the right-of-way and public easements for a period of one year from the final acceptance of the work, and shall make any necessary repairs at no cost to the City.
- Pavements shall be cut in neat, straight lines the full depth of the existing pavement, or as required by the City Engineer. Pavement replacement shall be conducted according to City of Columbus Standard Drawing 1441 Dr. A and applicable City of Dublin standard drawings. The replacement of driveways, handicapped ramps, sidewalks, bike paths, parking lot pavement, etc., shall be provided according to the approved construction drawings and City of Dublin standard construction drawings.
- Tree trimming within the construction zone is to be completed by a certified Arborist. At the completion of the project, the Arborist is to return and trim any broken branches as needed.
- Any modification to the work shown on drawings must have prior written approval by the City Engineer, City of Dublin.
- All inlets shall be channelized.
- Park areas shall be fine-graded and seeded with the following mixture:
Improved Kentucky Bluegrass, 40% of weight (2 varieties in equal parts)
Improved Perennial Rye, 60% of weight (2 varieties in equal parts)
Germination Rate: 85%
Application Rate: 7 lbs per 1000 sq ft or as directed by the Division of Parks & Recreation, City of Dublin, Ohio.
- Traffic control and other regulatory signs shall be Type S with a square post anchor base installation and meet all requirements of ODOT TC-41.20 and applicable City of Dublin specifications.
- Street signs shall meet all City of Dublin specifications with lettering colored in white displayed over a brown background. Sign tubing shall be brown in color and conform with the Type S, square post anchor base installation requirements of ODOT TC-41.20.

UTILITIES

- The following utilities are known to be located within the limits of this project:

Columbia Gas of Ohio Rob Caldwell – Leader Field Engineering 3550 Johnny Applesseed Ct. Columbus, Ohio 43231 Office: 614-818-2104 Cell: 614-370-1908 Customer Service: 1-800-344-4077 Damage Prevention: 1-866-632-6243 columbiagas_columbuseng@nsource.com Also copy: rcaldwell@nsource.com	City of Dublin Division of Engineering 6555 Shier Rings Road Dublin, Ohio 43016 (614)-410-4631 Charter Communications/Spectrum (aka Time Warner Communications) 3760 Interchange Road Columbus, Ohio 43221 DL-MOH-CONSTRUCTION-FRELO- TEAM@charter.com	Verizon Business (aka MCI/VO) 757 Commerce Ct Lewis Center, OH 43035 Cell: 614-593-6885 (Maurice Jones) Cell: 614-818-0361 (Bob Dilow) vs.net.columbus@verizon.com Also Copy: john.cornell@verizonwireless.com michael.henno@verizonwireless.com michael.sond@verizonwireless.com even.christianson@verizonwireless.com
American Electric Power Paul Paxton (City Projects/Distribution) Engineering Liaison Coordinator 777 Hopewell Drive Heath, Ohio 43056 Office: 740-348-5322 AEP Solution Center: 800-277-2177 ppaxton@aep.com Also copy: AEP Telecom Uno Blanuso ohfberrlocate@aep.com	City of Columbus Division of Water 210 Dublin Road, 2nd Floor Columbus, Ohio 43215 (614) 645-7877 AT&T of Ohio Tom Zeman 111 North 4th Street Columbus, OH 43215 (614) 222-7162	Breezeline (fka WOW) 3675 Corporate Drive Columbus, Ohio 43231 DL_CMHP@ATLANTACB.COM mfrey@breezeline.com

- The Contractor shall give notice of intent to construct to Ohio Utilities Protection Service (telephone number 800-362-2764), Producer's Underground Protection Service (telephone number 614-587-0486), and to owners of underground utilities that are not members of a registered underground protection service. Notice shall be given at least 2 working days before start of construction.
- The identity and locations of existing underground utilities in the construction area have been shown on the approved construction drawings as accurately as provided by the owner of the underground utility. The City of Dublin and the City Engineer assumes no responsibility for the accuracy or depths of underground utilities shown on the approved construction drawings. If damage is caused, the Contractor shall be responsible for repair of the same and for any resulting contingent damage.
- Location, support, protection and restoration of all existing utilities and appurtenances, whether shown or not shown on the approved construction drawings, shall be the responsibility of the Contractor.
- When unknown or incorrectly located underground utilities are encountered during construction, the

Contractor shall immediately notify the owner and the City Engineer.

- Public street lighting may be in the vicinity of this project. Contact the City of Dublin, Division of Engineering at 410-4637, two days prior to beginning work.

TRAFFIC CONTROL

- Traffic control shall be furnished, erected, maintained, and removed by the Contractor according to Ohio Manual of Uniform Traffic Control Devices (OMUTCD), current edition.
- All traffic lanes of public roadways shall be fully open to traffic from 7:00 AM to 9:00 AM and from 4:00 PM to 6:00 PM unless authorized differently by the City Engineer. At all other hours the Contractor shall maintain minimum one-lane two-way traffic. Uniformed, off-duty police officers shall replace flagmen designated by the OMUTCD, and shall be present whenever one-lane, two-way traffic control is in effect. Police cruisers may be required as directed by the City Engineer.
- If the City Engineer determines that the Contractor is not providing proper provisions for traffic control, the City Engineer shall assign uniformed, off-duty police officers to the project at no cost to the City.
- Steady-burning, Type "C" lights shall be required on all barricades, drums, and similar traffic control devices in use at night.
- Access from public roadways to all adjoining properties for existing residents or businesses shall be maintained throughout the duration of the project for mail, public water and sanitary sewer service, and emergency vehicles. The Contractor shall provide a traffic control plan detailing the proposed maintenance of traffic procedures. The traffic control plan must incorporate any traffic control details contained herein. The traffic control plan proposed by the Contractor must be approved by the City Engineer prior to construction.

EROSION AND SEDIMENT CONTROL

- The Contractor or Developer is responsible for submitting a Notice of Intent (NOI) to be reviewed and approved by the Ohio EPA. The NOI must be submitted to OEPA 45 days prior to the start of construction survey reference monuments or markers. In case of willful or careless destruction, the Contractor shall be responsible for restorations. A project location map must be submitted with the NOI. A sediment and erosion control plan must be submitted to the City Engineer for approval. If a sediment and erosion control plan has been submitted with the approved construction drawings, this plan must be made available at the project site at all times. The design of erosion control systems shall follow the requirements of Ohio EPA, Item 207 of Ohio Department of Transportation Standard Specifications, and the City Engineer. An Indiana NPDES Stormwater Discharge Permit may be required. The Contractor shall be considered the permittee.
- The Contractor shall provide sediment control at all points where storm water runoff leaves the project, including waterways, overland sheet flow, and storm sewers.
- Accepted methods of providing erosion/sediment control include but are not limited to: sediment basins, silt filter fence, aggregate check dams, and temporary ground cover. Hay or straw bales are not permitted.
- The Contractor shall provide adequate drainage of the work area at all times consistent with erosion control practices.
- Disturbed areas that will remain unworked for 30 days or more shall be seeded or protected within seven calendar days of the disturbance. Other sediment controls that are installed shall be maintained until vegetative growth has been established. The Contractor shall be responsible for the removal of all temporary sediment devices at the conclusion of construction but not before growth of permanent ground cover.

BLASTING (IF PERMITTED)

- The Contractor must obtain a blasting permit from Washington Township Fire Department prior to blasting for rock excavation. The Contractor shall submit blasting reports upon completion of blasting to the City Engineer, the Owner, and the Owner's engineer. Top of rock elevations shall be shown on "As-Built" construction drawings.

SANITARY SEWERS

- Connections to the sanitary sewer will be permitted upon receiving an OEPA Permit to Install (PTI), and upon receiving a satisfactory letter from the design engineer stating that the project has been constructed as per the plans, and all of the conditions of the PTI have been met. The developer is responsible for obtaining all required Ohio EPA approvals and paying review fees.
- Sanitary sewage collection systems shall be constructed in accordance with the rules, regulations, standards and specifications of the City of Dublin, Ohio EPA, Ohio Department of Health and the current edition of the Great Lakes – Upper Mississippi River Board (Ten States) – Recommended standards for wastewater facilities.
- The minimum requirements for sanitary sewer pipe with diameters 8 inches to 10 inches shall be PVC sewer pipe ASTM D3034, SDR 35. Pipe for 6 inch diameter house service lines shall be PVC pipe ASTM D3034, SDR 35. Pipe for depths greater than 28 feet. Pipe materials and related structures shall be shop tested in accordance with City of Columbus Construction Inspection Division quality control requirements.
- The minimum requirements for sanitary sewer pipes with diameters 12 inches to 30 inches shall be PVC sewer pipe, ASTM D3034, SDR 35 or SanITite HP pipe, ASTM F2736. Sanitary sewer pipes with diameters 30 inches to 60 inches shall be PVC sewer pipe, ASTM D3034, SDR 35 or SanITite HP pipe, ASTM F2764.
- All in-line wye and tee connections in concrete sewers, 18 inch diameter and larger, shall be either Kor-N-Tee or Kor-N-Seal connections conforming to the manufacturer's recommendations.
- Granular backfill shall be compacted granular material according to Item 912 of the Standard Specifications or Controlled Density Backfill according to Item 613, Type II of the Standard Specifications as directed by the City Engineer.
- All manhole lids shall be provided with continuous self-sealing gaskets. The approved construction drawings shall show where bolt-down lids are required. Sanitary sewer manholes shall be precast concrete or as approved by the City Engineer and conform to the City of Dublin sanitary manhole standard drawing. Manhole lids shall include City of Dublin logo.
- All PVC sewer pipes shall be deflection tested no less than 60 days after completion of backfilling operations. All other requirements shall be according to Item 901.21 of the Standard Specifications.
- Temporary bulkheads shall be placed in pipes at locations shown on the approved construction drawings and shall remain in place until the Permit to Install (PTI) has been issued by the OEPA and the sewers have been approved for use by the City Engineer. The cost for furnishing, installing, maintaining, and removing bulkheads shall be included in the contract unit bid price for the various sanitary sewer items.
- All sanitary sewers including sanitary sewer service lines shall be subjected to and pass infiltration or exfiltration tests according to Item 901 of the Standard Specifications and must be approved for use by the City Engineer before any service connections are tapped into sewers.
- For sanitary sewer infiltration, leakage through joints shall not exceed 100 gallons per inch of tributary sewer diameter per 24 hours per mile of length or the computed equivalent. All sanitary sewers shall be tested.

- At the determination of the City Engineer, the Contractor may be required to perform a TV inspection of the sanitary sewer system prior to final acceptance by the City. This work shall be completed by the Contractor at his expense.
- Visible leaks or other defects observed or discovered during TV inspection shall be repaired to the satisfaction of the Engineer.
- Roof drains, foundation drains, field tile or other clean water connections to the sanitary sewer system are strictly prohibited according to Section 51.23 of the Dublin Code of Ordinances.

- All water lines shall be located at least 10 feet horizontally and 18 inches vertically, from sanitary sewers and storm sewers, to the greatest extent practicable. Where sanitary sewers cross water mains or other sewers or other utilities, trench backfill shall be placed between the pipes crossing and shall be compacted granular material according to Item 912 of the Standard Specifications. In the event that a water line must cross within 18 inches of a sanitary sewer, the sanitary sewer shall be concrete encased or consist of ductile iron pipe material.
- Service risers shall be installed where the depth from weys to proposed ground elevation exceeds 10 feet. Tops of risers shall be no less than 9 feet below proposed ground elevation if basement service is intended.

- Where service risers are not installed, a minimum 5-foot length of sanitary sewer service pipe of the same size as the wye opening shall be installed.
- The Contractor shall furnish and place, as directed, approved wye poles made of 2 inches x 2 inches lumber at all wye locations, ends of extended services, or at the end of each riser where risers are required. Wye poles shall be visible before acceptance by the City. The cost of these poles shall be included in the contract unit price for the various sewer items.
- Existing sanitary sewer flows shall be maintained at all times. Costs for pumping and bypassing shall be included in the Contractor's unit price bid for the related items.
- The Contractor shall furnish all material, equipment, and labor to make connections to existing manholes. The sewer pipe to manhole connections shall be flexible and watertight. All holes shall be neatly cored. The sewer pipe barrel at the springline shall not extend more than 1 inch beyond the inside face of the manhole. To maintain flexibility in the connection, a 1-inch space shall be left between the end of the pipe inside the manhole and the concrete channel. This space shall be filled with a waterproof flexible joint filler. Any metal that is used shall be Type 300 Series Stainless Steel. The connection may be any of the following types:
 - Rubber sleeve with stainless steel bonding.
 - Kor-N-Seal as manufactured by National Pollution Control Systems, Inc.
 - Lock Joint Flexible Manhole Sleeve as manufactured by Interpace Corporation.
 - Or equal as approved by the City Engineer.
- Press Wedge II as manufactured by Press-Seal Gasket Corporation.
- Dura Seal III as manufactured by Dura Tech, Inc.
- Link-Seal as manufactured by Thunderline Corporation.
- Or equal as approved by the City Engineer.

The cost for this work along with a new channelized base for the manhole shall be included in the unit bid price for the related items of work.

WATERLINE

- An approved water supply capable of supplying the required fire flow for fire protection shall be provided to premises upon which by the contractor's expense. The use of sheet piling and bracing shall be determined per the means and methods of the Contractor. No separate payment shall be made for sheeting and bracing. At ALL times the Contractor shall be required to excavation in a manner that is safe to all workers and the general public. All OSHA requirements shall be upheld and sound safety practices shall be exercised at all times. Removal of sheeting and bracing items upon completion of work will be required as directed by the City of Columbus representatives.
- All water line materials shall be provided and installed according to current specifications of the City of Columbus Division of Water.
- All public water pipe with a diameter 3 inches to 8 inches shall be Ductile Iron, Class 53. Public water pipe 12 in diameter or larger shall be Ductile Iron, Class 54. Public water pipe 20 inches in diameter or larger may be prestressed concrete pipe. Private water pipe shall meet the approval of the City of Columbus Division of Water prior to approval of the construction drawings.

- Only fire hydrants conforming to City of Columbus standards will be approved for use.
- Public water lines shall be disinfectant by the City of Columbus Division of Water. Requests for water line chlorination shall be made through the City of Dublin Division of Engineering. The cost for chlorination shall be paid for by the Contractor.
- All water lines shall be disinfectant according to Item 801.13 of the Standard specifications. Special attention is directed to applicable sections of American Water Works Association specification C-651, particularly for flushing (Section 5) and for chlorinating valves and fire hydrants (Section 7). Pressure testing shall be performed in accordance with Section 801.12 of the City of Columbus Construction and Material Specifications. When water lines are ready for disinfection, the City of Dublin shall submit two (2) sets of "as-built" plans, and a letter stating that the water lines have been pressure tested and need to be disinfectant, to the City of Columbus, Division of Water. The Contractor shall be responsible for all costs associated with the disinfection construction per this plan. Pressure testing shall be performed in accordance with Section 801.12 of the City of Columbus Construction and Material Specifications.
- The Contractor shall paint all fire hydrants according to City of Dublin standards. The cost of painting fire hydrants shall be included in the contract unit price for fire hydrants.

- No water taps or service connection permits (e.g., to curb stops or meter pits) may be issued until adjacent public water lines serving the construction site have been disinfectant by the City of Columbus Division of Water and have been accepted by the City Engineer. A tap permit for each water service must be obtained from the City of Dublin and the City of Columbus Division of Water before making any taps into public water lines.
- The Contractor shall notify the City of Columbus Division of Water at 645-7788 and the City of Dublin Division of Engineering at least 24 hours before tapping into existing water lines.
- All water main stationing shall be based on street centerline stationing.
- All bends, joint deflections and fittings shall be backed with concrete per City of Columbus standards.
- The Contractor shall give written notice to all affected property owners at least 1 working day but not more than 3 working days prior to any temporary interruption of water service. Interruption of water service shall be minimized and must be approved by the City Engineer.
- Water meters shall be installed inside proposed structures unless a meter pit installation is approved by the City of Columbus Division of Water. Meter pits must conform to standard drawings L-7103, A&B for 5/8" through 1" meters or L-6317, A,B,C&D for 1-1/2" or larger meters.
- Water lines to be installed in embankment areas shall be placed after the embankment has been placed and compacted according to the Standard Specifications.
- Curb stop boxes shall be located at least 1 foot inside the right-of-way and set at finished grade.
- If the top of the operating nut of any valve is greater than 36 inches below finished grade, an extension stem shall be furnished to bring the top of the operating nut to within 24 inches of finished grade elevation.
- All water lines shall be placed at a minimum depth of 4 feet measured from top of finished grade to top of water line. Water lines shall be set deeper at all points where necessary to clear existing or proposed utility lines or other underground restrictions by a minimum of 18 inches.
18. Two 3/4 inch taps shall be installed within 2 feet of the end of the line on all dead-end water lines.

STORM SEWERS

- All storm water detention and retention areas and major flood routing swales shall be constructed to finish grade and hydrate-seeded and hydrate-mulched according to Items 203 and 659 of the Standard Specifications.
- Where private storm sewers connect to public storm sewers, the last run of private storm sewer connecting to the public storm sewer shall be Reinforced Concrete Pipe conforming to ASTM Designation C76, Wall B, Class IV for pipe diameters 12 inches to 15 inches, Class III for 18 inches to 24 inch pipes, and 27 inches and larger pipe shall be Class II, unless otherwise shown on the approved construction drawings. Inspection is required by the City of Dublin's Division of Engineering.
- Granular backfill shall be compacted granular material according to Item 912 of the Standard Specifications or Controlled Density Backfill according to Item 613, Type II of the Standard Specifications as directed by the City Engineer.
- All storm sewers shall be Reinforced Concrete Pipe conforming to ASTM Designation C76, Wall B, Class IV for pipe diameters 12 inches to 15 inches, Class III for 18 inches to 24 inch pipes, and 27 inches and larger pipe shall be Class II, unless otherwise shown on the approved construction drawings.
- Headwalls shall be required at all storm sewer inlets or outlets to and from stormwater management facilities. Natural stone and/or brick approved by the City Engineer shall be provided on all visible headwalls surfaces.
- Storm inlets or catch basins shall be channelized and have bicycle safe grates. Manhole lids shall include City of Dublin logo and curb in-belt and catch basin grates shall induce engraved lettering: "DUMP NO WASTE; DRAINS TO RIVER."
- Storm sewer outlets greater than 18 inches in diameter accessible from stormwater management facilities or watercourses shall be provided with safety grates, as approved by the City Engineer.
- HP Storm and HP SanITite or approved equal are approved alternatives to reinforced concrete pipe in paved and non paved areas as approved by the City Engineer. This includes applications inside the right-of-way.
- HP Storm and HP SanITite or approved equal pipe joints shall be watertight according to requirements of ASTM D3212. Pipes shall be joined with a gasketed integral bell & spigot joint meeting the requirements of ASTM F2881 (HP Storm) and ASTM F2764 (HP SanITite). Gaskets shall be installed by pipe manufacturer and covered with removable, protective wrap to ensure the gasket is free from debris. A joint lubricant available from the manufacturer shall be used on the gasket and bell during joint assembly.
- All bedding material shall be in accordance with City of Columbus standard construction drawing AA-S149.
- Backfill material shall be placed in accordance with Item 911 or Item 912 of the City of Columbus Construction Material Specifications (CMS).
- Backfill material in areas located outside the public right-of-way shall be placed in accordance with Item 901 of the City of Columbus (CMS).
- All HP Storm and Hp SanITite pipe (for storm sewer) shall be mandrel tested in accordance with City of Columbus Item 901.21, with the exception that the waiting period prior to testing shall be 30 days.

MAIL DELIVERY

- The Contractor shall be responsible to ensure that U.S. Mail delivery within the project limits is not disrupted by construction operations. This responsibility is limited to relocation of mailboxes to a temporary location that will allow the completion of the work and shall also include the restoration of mailboxes to their original location or approved new location. Any relocation of mailbox services must be first coordinated with the US Postal Service and the homeowner.
- Before relocating any mailboxes, the Contractor shall contact the U.S. Postal Service and relocate mailboxes according to the requirements of the Postal Service.

USE OF FIRE HYDRANTS

- The Contractor shall make proper arrangements with the Dublin Service Department and the Columbus Division of Water for the use of fire hydrants when used for work performed under this contract and provide the City of Dublin a copy of the Hydrant Usage Permit obtained from the City of Columbus. The Contractor shall also send copies of permits obtained from Dublin and Columbus to the Washington and/or Perry Township Fire Department. Permits shall be kept at the construction site at all times.
- Before the final estimate is paid, the Contractor shall submit a letter from the City of Columbus Division of Water to the City Engineer stating that the Contractor has returned the Siamese Valve to the City of Columbus and has paid all costs arising from the use of the fire hydrants.

MISCELLANEOUS - DEVELOPER NOTES

- High Density Polyethylene (HDPE) corrugated pipe with integrally formed smooth interior wall, ADS N-12 or approved equal, is an approved alternate to reinforced concrete pipe in paved and non-paved areas.
- HDPE pipe joints shall be made using watertight couplers with "O"-ring gasket, ADS WT of approved equal, where rubber "O"-ring gasket (ASTM C-361) pipe is required on approved construction plans or within contract documents. All other pipe shall have a bell and spigot joint with rubber gasket meeting ASTM F477.
- All bedding material shall be in accordance with City of Columbus Standard Construction Drawing AA-S149.
- Backfill material shall be placed in accordance with Item 911 of the City of Columbus Construction Material Specifications (CMS).
- Backfill material in areas located outside the public right-of-way shall be placed in accordance with City of Columbus Standard Construction Drawing AA-S155.
- Height of cover shall be in accordance with the Ohio Department of Transportation (ODOT) Location and Design (L&D) Manual, Volume Two, Section 100B.3.1.
- All HDPE pipe shall be mandrel tested in accordance with City of Columbus Item 901.21, with the exception that the waiting period prior to testing shall be 30 days.
- For any and all installations requiring the minimization of trench water migration, anti-seep collars shall be installed in accordance with the ODOT L&D Manual, Volume Two Section 111B.4.1.2 and ODOT Standard Hydraulic Construction Drawing WC-1.2.

AS-BUILTS

- As-builts of the site, utilities and stormwater management facilities shall be performed per requirements of the City of Dublin Administrative Policy & Procedure #08-030 prior to obtaining occupancy for the building.

SHEETING & BRACING

- Any sheeting and bracing necessary to install the proposed project improvements shall be furnished, installed, and maintained by the Contractor at the Contractor's expense. The use of sheet piling and bracing shall be determined per the means and methods of the Contractor. No separate payment shall be made for sheeting and bracing. At ALL times the Contractor shall be required to excavation in a manner that is safe to all workers and the general public. All OSHA requirements shall be upheld and sound safety practices shall be exercised at all times. Removal of sheeting and bracing items upon completion of work will be required as directed by the City of Columbus representatives.

ITEM SPECIAL - DEWATERING

In the event that dewatering is necessary, the Contractor is required to prepare a dewatering plan that will describe how the dewatering operation will be completed and how the pump effluent will be managed. Reference the soils report for discussion of groundwater consideration. The cost for dewatering operations shall be included in the price bid for the storm and sanitary sewer improvement. This plan will be presented to the City for review prior to any dewatering operations. The Contractor shall be solely responsible to the O.D.N.R. for the registry, maintenance and abandonment of any withdrawal devices used in the construction of this project.

Installation of any well, well point pit, or other withdrawal device used for the purpose of removing groundwater for the purpose of removing groundwater from an aquifer. This is in accordance with the applicable requirements of the Ohio Department of Natural Resources.

Installation of any well, well point, pit or other device used for the purpose of lowering the groundwater level to facilitate construction of this project shall be properly abandoned in the provisions of Section 3745-9-10 of the Ohio Administrative Code or as directed by the Ohio Department of Natural Resources Director or his representatives. The Contractor is solely responsible to the Ohio Department of Natural Resources (O.D.N.R.) for registry, maintenance, and abandonment of any withdrawal devices used in the construction of this project.

The Contractor shall be required to complete and file a Well Log and a Drilling Report Form with O.D.N.R., Division of Water, within 30 days of the completion of installation of any well, well point, pit or other device used for the purpose of removing groundwater from an aquifer. This is in accordance with Sections 1521.01 and 1521.05 of the Ohio Revised Code. In addition, any such facility that has a capacity to withdraw waters of the state in an amount greater than 100,000 gallons per day from all sources shall be registered by the Contractor with the Chief of the O.D.N.R., Division of Water, within three months of the completion of the facility. In accordance with Section 1521.16 of the Ohio Revised Code. Copies of the necessary paperwork can be obtained at O.D.N.R., Division of Water, Fountain Square, Columbus, Ohio, 43224-1387. Phone: (614)265-8717.

The Contractor shall furnish and operate suitable pumping equipment of such capacity adequate to dewater the trench should water be encountered. The trench shall be sufficiently dewatered so that the placement of bedding and the laying and joining of pipe is made on firm, dry ground. If dewatering operations should be required to dewater the trench, the Contractor shall be responsible for the removal and replacement of any equipment, such as pumps, hoses, and materials shall be removed and replaced by Item 906, stone foundation and shall be included in the price bid for the various sewer items.

The Contractor shall convey all trench water to a natural drainage channel or storm sewer without damage to property. The Contractor shall be responsible to place and maintain the necessary sediment control measures to filter the dewatering discharge. Direct discharge of sediment laden water to the City's sewer system or a receiving stream is a violation of Ohio EPA and City of Columbus regulations; the Contractor will be held liable for the violation and subsequent fines.

The cost of any dewatering operations required for the construction of the storm sewer shall be included in the price bid for the various sewer items. No separate payment shall be made.

If during construction of the sewer, the water wells belonging to nearby residences are dewatered, for possible storm flows that may typically be expected during the seasons that the work is in progress. The Contractor shall provide a watertight seal to the well is unable to be recommissioned after construction, a tap to a waterline shall be provided if available or another well dug, at no extra cost to the residents.

ITEM SPECIAL - BYPASS PUMPING (COMPLETE)

Bypass pumping is required wherever the flow in any sewer is disrupted by construction of new sewer segments, sewer systems, manholes, or associated activities. Bypass pumping must provide for possible storm flows that may typically be expected during the seasons that the work is in progress. The Contractor shall provide a contingency plan to prevent damage during high flows. The City will not be responsible for damages due to high flows.

The Contractor shall convey all water to a natural drainage channel or storm sewer without damage to property by utilizing proper erosion and sediment controls. Direct discharge of sediment laden water to the City's sewer system or a receiving stream is a violation of Ohio EPA and City of Columbus regulations. The Contractor will be held liable for any violation and subsequent fines. The Contractor shall be responsible to place and maintain the necessary sediment control measures to filter the dewatering discharge. Cost for the above shall be included in the price bid for the project improvements.

Bypass pumping shall be polyethylene with butt-fused joints, the pump and bypass lines shall be of adequate capacity and size to handle average and peak flows.

Bypass pumping or fluming shall continue until work in the section of sewer involved has been completed, tested, inspected, and approved for use. Coordinate with City Inspector for pumping system maintenance requirements.

Under no circumstances will dumping of raw sewage on private property or City streets be allowed. Raw sewage spilled shall be leamed and disinfected by the contractor. Spills must be reported immediately to the dispatcher of the sewer maintenance operation center (SMOC). 614-645-7102.

The cost of the bypass pumping including all labor, material, and equipment shall be paid at the lump sum special "Bypass Pumping (Complete)". The cost of any bypass pumping required for the construction of storm sewers shall be included in the price bid for the various sewer items.



600 Main Street
Suite 300
North Little Rock, AR 72114
Phone: 501-758-7443

www.taggarch.com

FINAL
DEVELOPMENT PLAN
NOT FOR
CONSTRUCTION



Evans, Mechwart, Hambleton & Tilton, Inc.
Engineers + Surveyors + Planners + Scientists
5502 New Albany Road, Columbus, OH 43054
Phone: 614.775.4500 Toll Free: 888.775.5348
emht.com

Bypass pumping or fluming shall continue until work in the section of sewer involved has been completed, tested, inspected, and approved for use. Coordinate with City Inspector for pumping system maintenance requirements.

Under no circumstances will dumping of raw sewage on private property or City streets be allowed. Raw sewage spilled shall be leamed and disinfected by the contractor. Spills must be reported immediately to the dispatcher of the sewer maintenance operation center (SMOC). 614-645-7102.

The cost of the bypass pumping including all labor, material, and equipment shall be paid at the lump sum special "Bypass Pumping (Complete)". The cost of any bypass pumping required for the construction of storm sewers shall be included in the price bid for the various sewer items.



NEUROLOGICAL
TRANSITIONAL
CENTER

DUBLIN, OH

PROJECT NAME

SEAL

REVISIONS

NO.	DESCRIPTION	DATE

GENERAL NOTES

SHEET NAME

October 19, 2022

DATE

PROJECT NUMBER 2022037

C0.2

SHEET NUMBER

J:\2022\20237\DWG\945Sheets\Plan Set\20220237 General Notes.dwg, Last Saved By: pschoeffer, 8/16/2022 4:49 PM, Last Printed By: pschoeffer, Phillip, 10/19/2022 9:29 AM (No Xrefs)

FINAL
DEVELOPMENT PLAN
NOT FOR
CONSTRUCTION



NEUROLOGICAL
TRANSITIONAL
CENTER

DUBLIN, OH

PROJECT NAME _____

SEAL _____

REVISIONS

NO.	DESCRIPTION	DATE

LEGEND

SHEET NAME _____

DATE October 19, 2022

PROJECT NUMBER 20220237

SHEET NUMBER **C0.3**

LEGEND

EXISTING CONDITIONS		PROPOSED LAYOUT	
-----	CENTERLINE SURVEY	-----	CENTERLINE CONSTRUCTION
=====	EDGE OF PAVEMENT	=====	EDGE OF PAVEMENT
-----	CURB	-----	BACK OF CURB
-----	SIDEWALK	-----	FACE OF CURB
-----	DRIVEWAY	-----	SIDEWALK/BIKEPATH
X X X X X	FENCE	X X X X X	FENCE
-----	GUARDRAIL	-----	GUARDRAIL
-----	CORP LINE	-----	RIGHT OF WAY
-----	RIGHT OF WAY	-----	PERMANENT SIDEWALK EASEMENT
-----	Ex. SH	-----	UTILITY EASEMENT
-----	Ex. R/W	-----	SEWER EASEMENT
-----	PROPERTY LINE	-----	TEMP. CONSTRUCTION EASEMENT
-----	LOT LINE	-----	CONSTRUCTION LIMITS
-----	INTERNAL LOT LINE	-----	SWALE
-----	DITCH	-----	WATER MAIN
-----	WM	-----	WM
X X X X X	WATER TO BE ABANDONED	-----	WS
-----	WS	-----	DWS
-----	WATER SERVICE	-----	DWS
-----	SANITARY	-----	FWS
-----	STORM	-----	FWS
-----	COMBINATION STORM & SEWER	-----	STM
-----	GAS	-----	STM
-----	GS	-----	RD
-----	GAS SERVICE	-----	RD
-----	TELEPHONE	-----	GM
-----	C	-----	GM
-----	ELECTRIC	-----	C
-----	OHE-OHC	-----	C
-----	OVERHEAD ELECTRIC COMMUNICATION	-----	COB
-----	COC-DOT	-----	COB
-----	COLUMBUS DEPT OF TECHNOLOGY	-----	E
-----	CATV	-----	E
-----	CABLE TV	-----	EDB
-----	FO	-----	EDB
-----	LIGHTING	-----	FO
-----	TR	-----	FO
-----	TRAFFIC	-----	UGL
-----	STEM	-----	UGL
-----	STEM	-----	TR
-----	STEM	-----	TR
-----	STEM	-----	NT
-----	STEM	-----	NT

EXISTING SYMBOLS	PROPOSED SYMBOLS
○ FIRE HYDRANT	● SAN/STM MANHOLE
⊗ WATER VALVE	● SAN/STM CLEANOUT
○ SANITARY MANHOLE	■ CURB INLET
○ STORM MANHOLE	■ CATCH BASIN
⊕ GRATED STM MANHOLE	■ YARD DRAIN
⊕ CURB INLET MANHOLE	⊕ STM MANHOLE W/ GRATE
⊕ CURB & GUTTER INLET	⊕ GUY ANCHOR
⊕ CATCH BASIN	⊕ LIGHT POLE
⊕ GAS VALVE	⊕ SIGNAL POLE
⊕ GAS METER	⊕ SIGNAL PULL BOX
⊕ PULLBOX	⊕ PULLBOX
⊕ EMERGENCY CALL BOX	
⊕ TRAFFIC PULL BOX	
⊕ SIGNAL CONTROLLER	
▭ BUILDING	
▭ PARKING BLOCK	
▭ SIGNS	
▭ BENCHMARK	
▭ SOIL BORING	
▭ GUY ANCHOR	
▭ HEDGE/SHRUB	
○ TREES	
○ STUMP	
○ BUSH	
○ TREES TBR	

ABBREVIATIONS	
Ex	EXISTING
Prop	PROPOSED
1"WS	1" WATER SERVICE
6"SS	6" SANITARY SERVICE
6"RD	6" ROOF DRAIN
1"GS	1" GAS SERVICE
WM	WATER MAIN
WV	WATER VALVE
WSB	WATER SERVICE BOX
NF	NOT FOUND
MH	MANHOLE
CB	CATCH BASIN
C&G	CURB & GUTTER
CI	CURB INLET
CIMH	CURB INLET MANHOLE
GM	GAS MAIN
OHC	OVERHEAD COMM.
OHE	OVERHEAD ELECTRIC
UGE	UNDERGROUND ELECTRIC
DB	DUCT BANK
CATV	CABLE TELEVISION
UGL	UNDERGROUND LIGHTING
SGNL	TRAFFIC SIGNAL
(PA)	PREVIOUSLY ABANDONED
Vert	VERTICAL
Horz	HORIZONTAL
DW	DEFLECTION
CL	CENTERLINE
EP	EDGE OF PAVEMENT
(DND)	DO NOT DISTURB
(FIP)	FILL IN PLACE
(TBA)	TO BE ABANDONED
(TBAO)	TO BE ABANDONED (BY OTHERS)
(TBR)	TO BE REMOVED
(TBR)	TO BE REMOVED (BY OTHERS)
(TBR)	TO BE REMOVED AND SALVAGED
(TBR)	TO BE RELOCATED
(TBR)	TO BE RELOCATED (BY OTHERS)
(TBV)	TO BE VACATED
(ATG)	ADJUST TO GRADE
(ATG)	ADJUST TO GRADE (BY OTHERS)
(RTG)	RECONSTRUCT TO GRADE
(R&R)	REMOVE AND RESET
(R&B)	REMOVE AND REBUILD
(REM)	REMOVE
(APP)	AS PER PLAN
(BO)	BY OTHERS

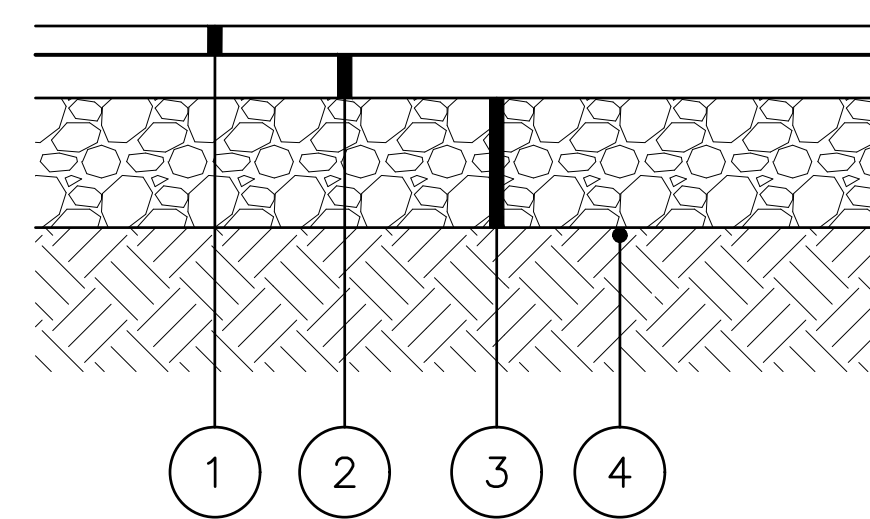

- ① Item 441, 1 1/4" Asphalt Concrete, Surface Course, Type 1, Medium Traffic, PG 64-22
- ② Item 441, 1 3/4" Asphalt Concrete, Intermediate Course, Type 2, Medium Traffic, PG 64-22
- ③ Item 304, 8" Aggregate Base
- ④ Item 204, Subgrade Compaction

LIGHT DUTY PAVEMENT SECTION
No Scale

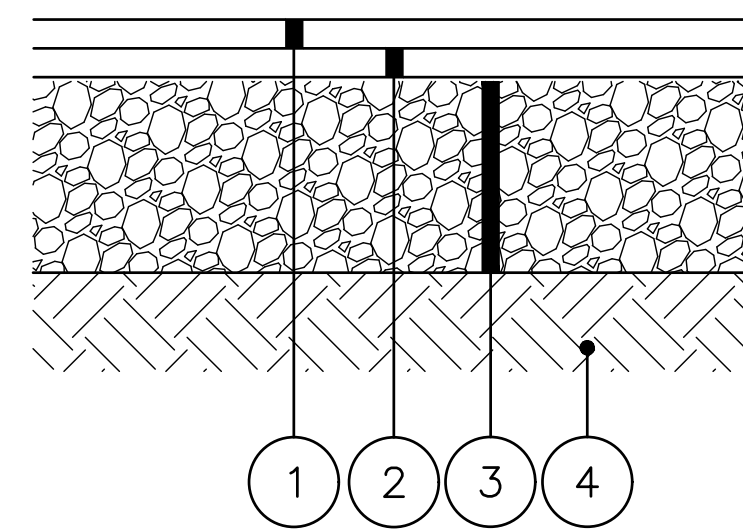

- ① Item 441, 1 1/4" Asphalt Concrete, Surface Course, Type 1, Medium Traffic, PG 64-22
- ② Item 441, 2 3/4" Asphalt Concrete, Intermediate Course, Type 2, Medium Traffic, PG 64-22
- ③ Item 304, 10" Aggregate Base
- ④ Item 204, Subgrade Compaction

HEAVY DUTY PAVEMENT SECTION
No Scale

NOTES:

Pavement sections are per geotechnical report from Geotechnical Consultants Inc. dated 09/06/2022.

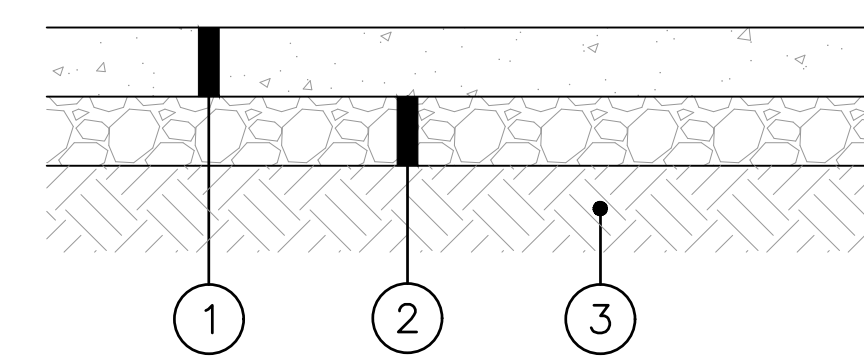

- ① Item 608, 4" Concrete Walk.
- ② Item 304, 4" Aggregate Base.
- ③ Item 204, Subgrade Compaction.

NOTES:

See Landscape Plans for joint and finish specifications.

CONCRETE WALK - PER DUBLIN STD DWG RD-05

No Scale

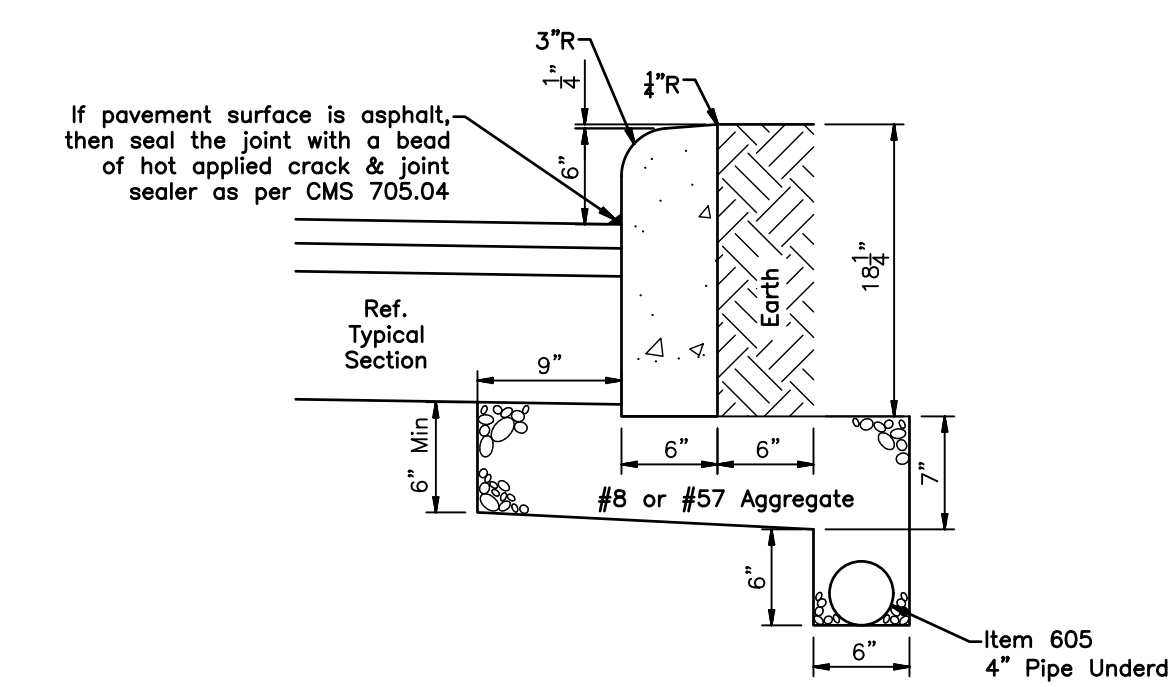

Note:

All Exposed Surfaces of Concrete Curb shall have a Brush Finish.

STRAIGHT 18" CONCRETE CURB

No Scale

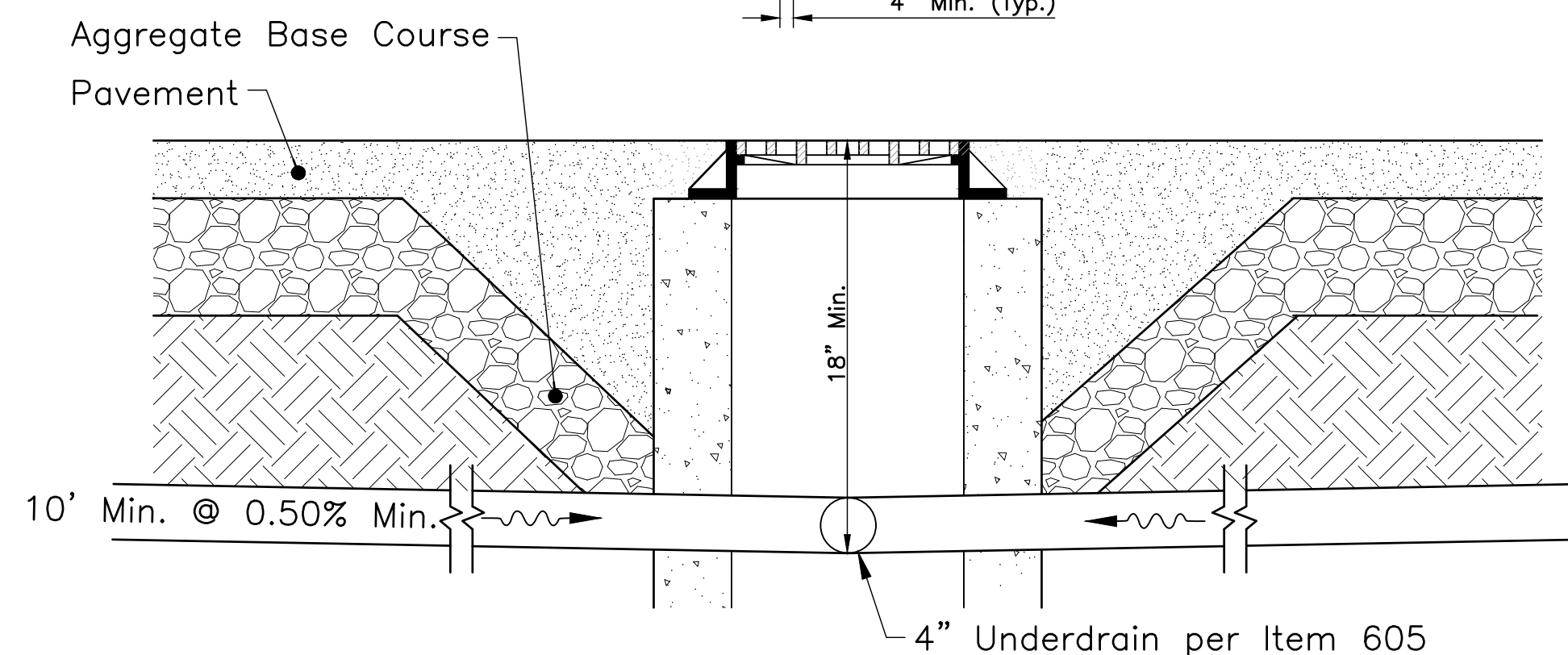
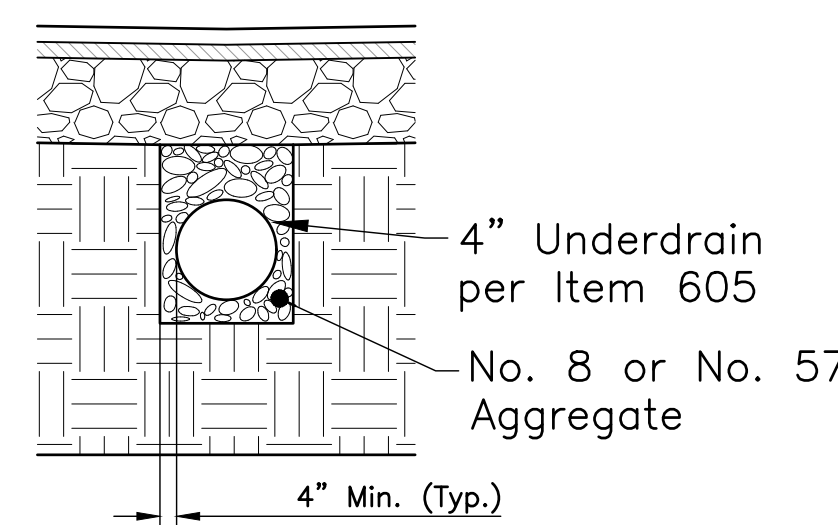

NOTES:

- 1. Extend 4" underdrains 10' minimum as shown on grading plan. Minimum 2'-6" of cover on underdrains. Slope to drain towards structure.
- 2. The Contractor shall initially set the top of casting for an inlet structure within the paved areas to the elevation of the intermediate pavement course.
- 3. Prior to final paving of surface course the Contractor shall adjust the top of casting to finish pavement grade.

TYPICAL SECTION FOR STRUCTURES WITHIN PAVEMENT

No Scale

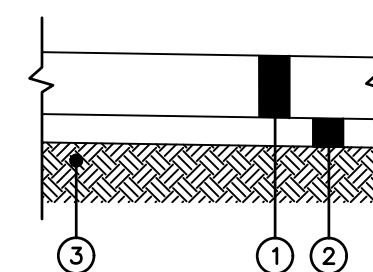

CONCRETE PAVEMENT SECTION

No Scale

- ① Item 452, 8" Air-Entrained Portland Cement Concrete Pavement, Class MS
- ② Item 304, 4" Aggregate Base
- ③ Item 204, Subgrade Compaction

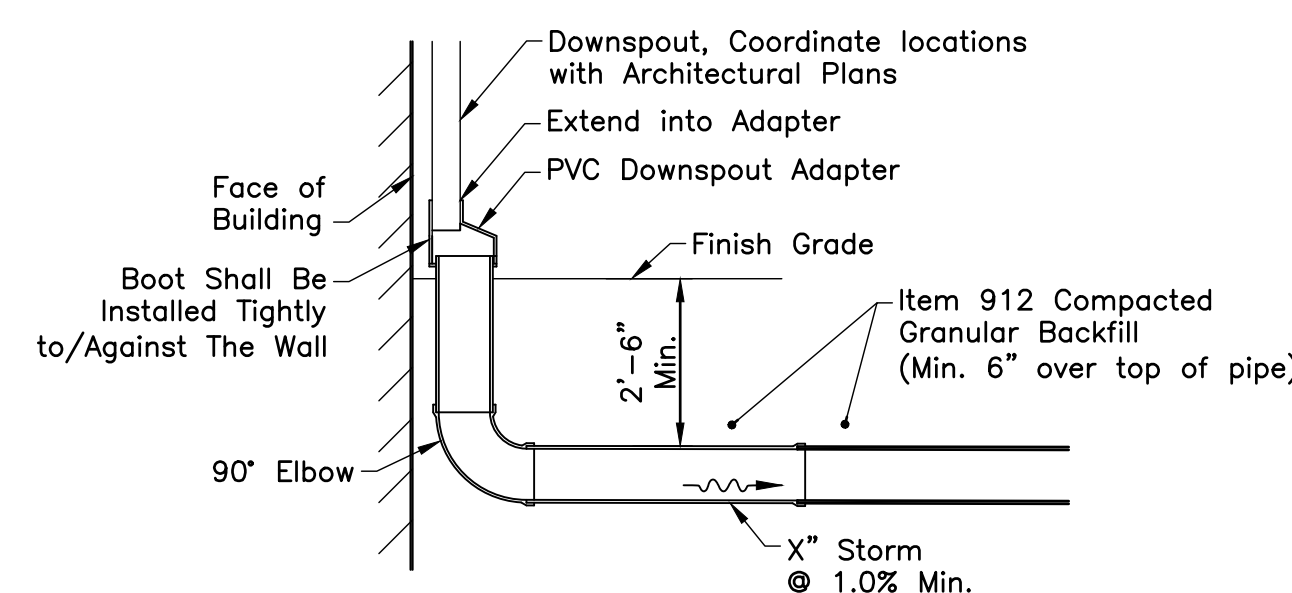

DOWNSPOUT CONNECTION DETAIL

No Scale

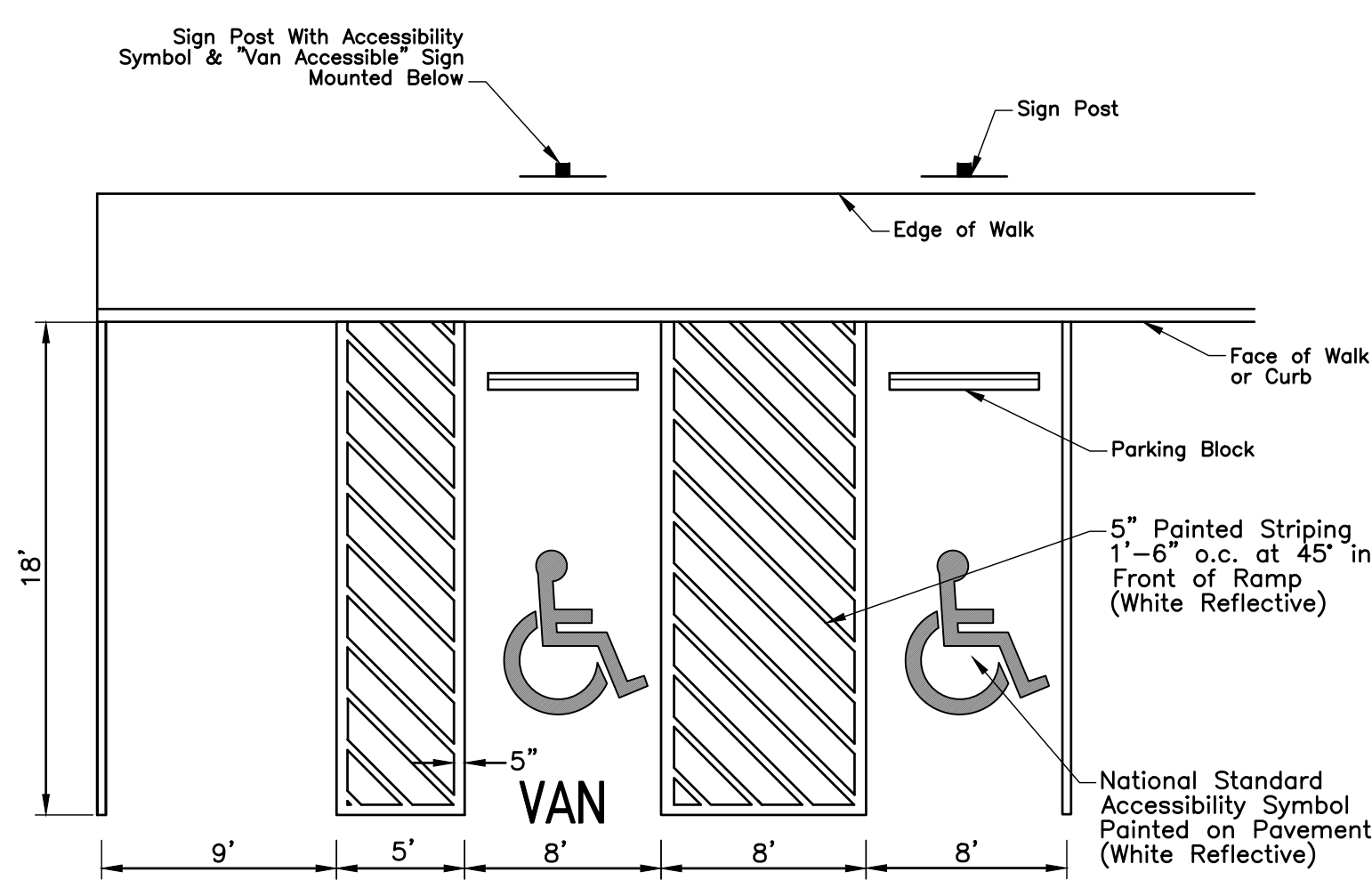

NOTES:

- 1. Pavement shall have a maximum 2.00% slope in all directions in the area of handicap parking spaces and associated striping.
- 2. Handicap parking sign shall conform with current State and Local codes and regulations.
- 3. Transition from flush curb to full height curb as designated on Grading Plan. Slope walk to match curb.

ADA PARKING STRIPING DETAIL

No Scale

NO.	DESCRIPTION	DATE

J:\2022\20237\DWG\045\Sheets\Plan_Sea\Plan_Sheets.dwg, Last Saved By: pschaeffer, 10/19/2022 9:28 AM, Last Printed By: pschaeffer, Phillip, 10/19/2022 9:29 AM (No Xrefs)

MATCH LINE - SEE BELOW

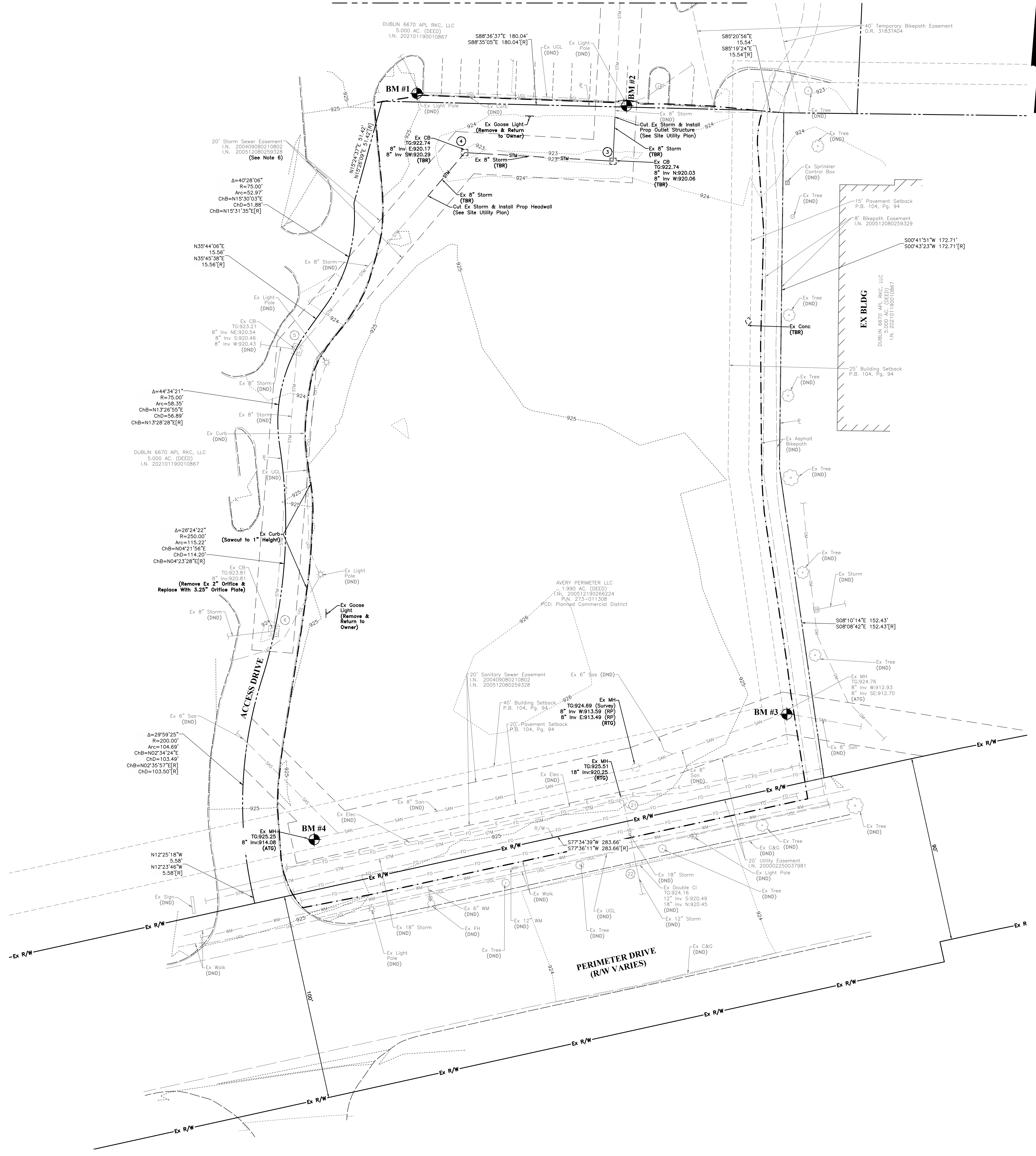

NOTES:

- 1. The existing conditions & demolition plan depict site conditions prior to any construction activity being performed within this area. The Contractor shall complete a field visit prior to starting construction to verify site conditions and demolition within the limits of disturbance.
2. CAUTION: The existing utilities on this plan are shown in their approximate location. The Contractor shall be responsible for contacting OUPS and to field locate existing utilities prior to construction.
3. Any existing storm inlets impacted by the new construction activities will need the appropriate inlet protection for sediment control.
4. Contractor shall use extreme caution while performing any work around the existing utilities and ensure all regulations and requirements have been met. Contractor shall contact the utility companies to protect/cover their lines as appropriate and ensure that when performing tree removals near the overhead utilities that no damage occurs to the overhead utilities and poles. If damage occurs the Contractor shall stop work immediately within the general vicinity and contact the utility owner to report damage to the utility.
5. Contractor shall protect existing hardscape and landscape that is to remain. Damage caused by the construction of this project must be repaired/replaced to the next adjacent joint as needed to create a uniform final condition that eliminates random joint patterns. No additional payment shall be made.
6. Easement adjustments to be further coordinated with the City of Dublin and the developer during the engineering permit review process.

SURVEYED BY:

EMH&T INC.
Heather King, PS
5500 New Albany Rd
Columbus, Ohio 43054
Tel: (614) 775-4120
Email: hking@emht.com
Date of Survey: April 30, 2022

BENCH MARKS

The elevations shown on this map are based on the North American Vertical Datum of 1988. Said elevations are based upon positional solutions derived from RTK GPS observations using the Ohio Department of Transportation Virtual Reference System equipment and software and the National Geodetic Survey's GEOID12B model at traverse control points were then transferred by conventional leveling procedures to the permanent benchmarks listed hereon. (Fieldwork Completed 4/2019).

- BM #1 Chiseled square on the south side of a concrete light pole base located 90 feet southeast of the northeast corner of 6670 Perimeter Drive. N:767807 E:1782181 Elev. = 926.77 (NAVD 88)
BM #2 Chiseled square on the south side of a concrete light pole base located 180 feet southeast of the northeast corner of 6670 Perimeter Drive. N:767801 E:1782283 Elev. = 926.27 (NAVD 88)
BM #3 Chiseled triangle on the east side of a sanitary manhole rim located 60 feet north of Perimeter Drive and 270 feet east of the entrance drive of 6670 Perimeter Drive. N:767505 E:1782361 Elev. = 924.76 (NAVD 88)
BM #4 Chiseled triangle on the east side of a sanitary manhole rim located 50 feet north of Perimeter Drive and 30 feet east of the entrance drive of 6670 Perimeter Drive. N:767444 E:1782131 Elev. = 925.25 (NAVD 88)

SURVEY NOTE:

- 1. This survey was prepared using documents of record, prior plats of survey, and observed evidence located by an actual field survey.

BASIS OF BEARING:

- 1. The bearings shown on this survey are based on the Ohio State Plane Coordinate System, South Zone, NAD 83 (2011). The portion of the centerline of Perimeter Drive, having a bearing of North 77° 34' 39" East and monumented as shown hereon, is designated as the 'basis of bearings' for this survey.



600 Main Street
Suite 300
North Little Rock, AR 72114
Phone: 501-758-7443

www.taggarch.com

FINAL DEVELOPMENT PLAN NOT FOR CONSTRUCTION



Evans, Mechwart, Hambleton & Tilton, Inc.
Engineers + Surveyors + Planners + Scientists
5500 New Albany Road, Columbus, OH 43054
Phone: 614.775.4500 Toll Free: 888.775.3448
emht.com



NEUROLOGICAL TRANSITIONAL CENTER

DUBLIN, OH

PROJECT NAME _____

SEAL _____

REVISIONS

Table with 3 columns: NO., DESCRIPTION, DATE

EXISTING CONDITIONS AND DEMOLITION PLAN

SHEET NAME _____

DATE October 19, 2022

PROJECT NUMBER 20220237

SHEET NUMBER C0.5

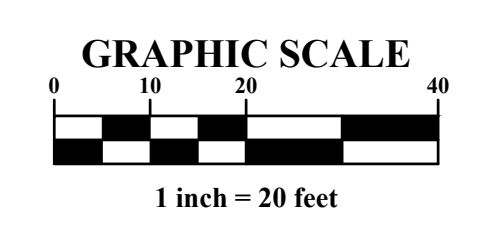

MATCH LINE - SEE ABOVE

J:\2022\20237\DWG\945Sheets\Plan_Sea\Plan_Sheets.dwg, Last Saved By: pschoeffler, 10/19/2022, 9:59 AM, Last Printed By: pschoeffler, Phillip, 10/19/2022, 3:27 PM (No Xrefs)

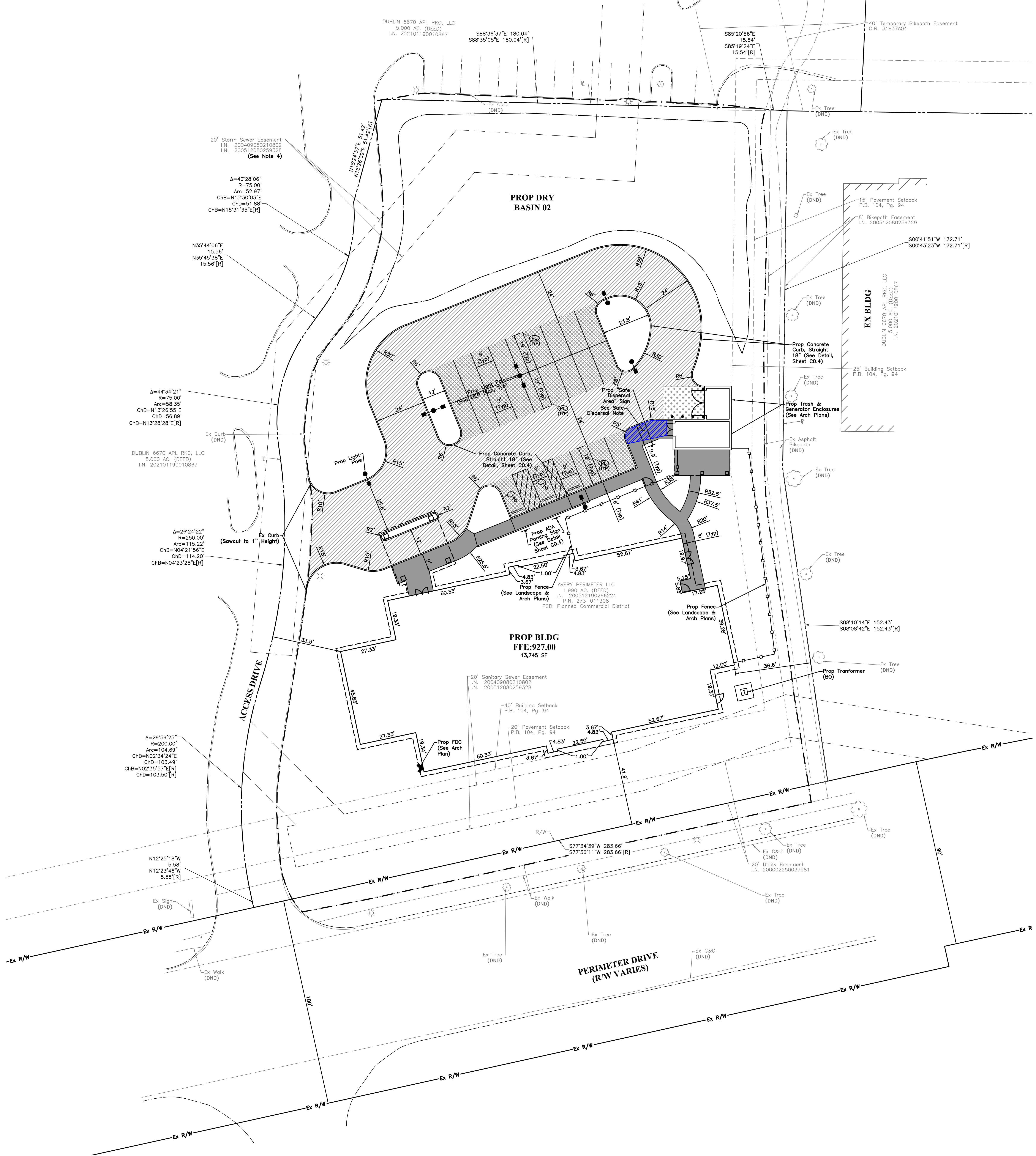

NOTES:

- Items To Be Abandoned/Removed have NOT been shown for clarity purposes. See Existing Conditions & Demolition Plan On Sheet C0.5 for additional information.
- All dimensions within pavement are given from face of curb or edge of pavement/sidewalk. All radii are 5' unless otherwise noted.
- Proposed pavement markings shall be per Item 644 unless otherwise noted.
- Easement adjustments to be further coordinated with the City of Dublin and the developer during the engineering permit review process.
- Reference Landscape Plan, Sheet L0.1, for Sight Distance Triangles.

ITEM 644 LINE SPECIFICATIONS (Except Where Noted)	
XW	Crosswalk Line, 10" White
A	Lane Arrow
PL	Parking Line, 4" White
PS	Parking Line (Reference Landscape Architect Plans)
CH	Channelizing Line, 10" White
R	Removal of Pavement Marking
SL	Stop Line, 20" White
WP	Word on Pavement, 22"
WE	Edge Line, 5" White
YE	Yellow Edge Line, 5"
YT	Transverse Line, 20" Yellow
DY	Center Line, 5" Solid Double Yellow
CSD	Center Line, 5" Solid & Dashed Yellow

LEGEND

- Item 608 - 4" Concrete Walk (See Detail, Sheet C0.4)
- Proposed Heavy Duty Pavement (See Detail, Sheet C0.4)
- Proposed Light Duty Pavement (See Detail, Sheet C0.4)
- Proposed Concrete Pavement (See Detail, Sheet C0.4)
- Proposed Safe Dispersal Area (See Safe Dispersal Note)

PARKING TABLE

Total Parking Required:	15 Spaces
Parking Provided:	24 Spaces
ADA Parking Required:	2 Spaces
ADA Parking Provided:	2 Spaces

BUILDING HEIGHT TABLE

Allowable Building Height:	35'-0"
Building Height:	22'-0"

Note: These heights were derived based on PUD text.

SAFE DISPERSAL NOTE:

- Due to security reasons and Per Code 1028.5, this project is proposing a safe dispersal area (as an exception to the unobstructed access to public way). This safe dispersal area:
- Accommodates more than 5 square feet for each person (135 SF required to meet code and 155 SF provided).
 - The area is located on the same lot and not less than 50 feet (15240 mm) away from the building requiring egress.
 - The area will be permanently maintained and identified as a safe dispersal area.
 - The area has multiple safe and unobstructed paths of travel from the building.



600 Main Street
Suite 300
North Little Rock, AR 72114
Phone: 501-758-7443

www.taggarch.com

**FINAL
DEVELOPMENT PLAN
NOT FOR
CONSTRUCTION**



Evans, Mechwart, Hambleton & Tilton, Inc.
Engineers + Surveyors + Planners + Scientists
5500 New Albany Road, Columbus, OH 43054
Phone: 614.775.4500 Toll Free: 888.775.3648
emht.com



**NEUROLOGICAL
TRANSITIONAL
CENTER**

DUBLIN, OH

PROJECT NAME _____

SEAL _____

REVISIONS

NO.	DESCRIPTION	DATE

**SITE AND DIMENSION
PLAN**

SHEET NAME _____

DATE October 19, 2022

PROJECT NUMBER 20220237

SHEET NUMBER **C0.6**

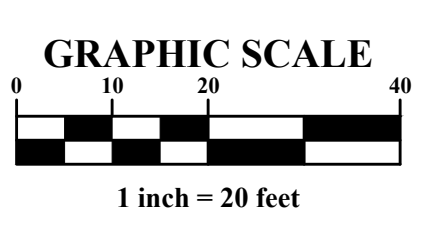

SITE NARRATIVE

PLAN DESIGNER: EMHT Inc.
Joe Walker, PE
5500 New Albany Road
Columbus, Ohio 43054
Tel: (614) 775-4629
Fax: (614) 775-4800

OWNER/DEVELOPER: Select Medical
Nick Belfer
4714 Gettysburg Road
Mechanicsburg, PA 17055
Tel: (717) 215-4411

PROJECT DESCRIPTION: This project consists of a new medical office building, parking lot and site infrastructure.

DISTURBED AREA: 1.85 Acres

EXISTING SITE CONDITIONS: Pre-Development conditions of this site consist of green space.

RECEIVING STREAM: The stormwater runoff from the site drains to the the South Fork of Indian Run.

ADJACENT AREAS: This project is bordered by Post Road to the north, Associated Orthodontics to the east, the Perimeter Professional Center to the west, and Perimeter Drive to the south.

EROSION AND SEDIMENT MEASURES: ESC measures for this site consist of perimeter controls, inlet protection, and Stormtech Isolation Rows.

PERMANENT STABILIZATION: Disturbed areas will be stabilized per the temporary and permanent seeding requirements on this sheet.

MAINTENANCE: It is the Contractor's responsibility to maintain the sedimentation and erosion control features on this project. Any sediment or debris which has reduced the efficiency of a control shall be removed immediately. Should a structure or feature become damaged, the Contractor shall repair or replace at no additional cost to the owner.

CONSTRUCTION SEQUENCE:

1. Ensure a copy of the SWPPP and NOI approval letter are available on-site during working hours.
2. Remove existing orifice plate from existing structure 1 & modify structure per detail on sheet C1.1.
3. Remove existing orifice plate from existing structure 2.
4. Construct sediment basin. Ensure the permanent water quality orifice is not installed during the sediment basin phase. Cut existing 8" storm and connect it to the sediment basin.
5. Install construction entrance.
6. Install perimeter controls and inlet protection as shown on the plan.
7. Begin clearing and grading activities.
6. Disturbed areas that are to remain idle for more than 14 days shall be temporarily stabilized.
7. Commence the construction of the site infrastructure.
8. Permanently stabilize the remaining disturbed areas.
9. Convert the sediment basin to the final dry stormwater basin per the grading and landscape plans.
10. Once vegetation is established, remove the erosion and sediment controls. Reseed any disturbed areas.

SCHEDULE: The Contractor shall provide a schedule of operations to the owner. Sedimentation and erosion control features shall be placed in accordance with this schedule.

OHIO EPA NPDES FACILITY PERMIT NUMBER: Pending

SITE CONTACT: Select Medical
Nick Belfer
4714 Gettysburg Road
Mechanicsburg, PA 17055
Tel: (717) 215-4411

BMP Installation	Nick Belfer	Tel: 717 215-4411	Email: NBelfer@selectmedical.com
BMP Maintenance	Same as above	Same as above	Same as above
Site Stabilization and BMP Removal	Same as above	Same as above	Same as above

TABLE 2: TEMPORARY STABILIZATION

AREA REQUIRING TEMPORARY STABILIZATION	TIME FRAME TO APPLY EROSION CONTROL
Any areas within 50 feet of a surface water of the state and at final grade	Within two days of the most recent disturbance if the area will remain idle for more than fourteen days
For all construction activities, any disturbed areas that will be dormant for more than 21 days but less than one year, and not within 50 feet of a surface water of the state	Within seven days of the most recent disturbance within the area
Disturbed areas that will be idle over winter	For residential subdivisions, disturbed areas must be stabilized at least seven days prior to transfer of permit coverage for the individual lot(s)
	Prior to the onset of winter weather

TABLE 1: PERMANENT STABILIZATION

AREA REQUIRING PERMANENT STABILIZATION	TIME FRAME TO APPLY EROSION CONTROL
Any areas that will lie dormant for one year or more	Within seven days of the most recent disturbance
Any areas within 50 feet of a surface water of the state and at final grade	Within two days of reaching final grade
Any areas at final grade	Within seven days of reaching final grade within that area

TEMPORARY SEEDING SPECIES SELECTION

SEEDING DATES	SPECIES	LB./1,000 ² FT.	LB. PER AC.
MARCH 1 TO AUGUST 15	OATS	3	128 LB.(4 BUSHEL)
	TALL FESCUE	1	40 LB.
	ANNUAL RYEGRASS	1	40 LB.
AUGUST 16 TO NOVEMBER 1	PERENNIAL RYEGRASS	1	40 LB.
	TALL FESCUE	1	40 LB.
	ANNUAL RYEGRASS	1	40 LB.
	ANNUAL RYEGRASS	1.25	55 LB.
	PERENNIAL RYEGRASS	3.25	142 LB.
	CREeping RED FESCUE	0.4	17 LB.
NOV. 1 TO SPRING SEEDING	KENTUCKY BLUEGRASS	0.4	17 LB.
	OATS	3	128 LB.(3 BUSHEL)
	TALL FESCUE	1	40 LB.
	ANNUAL RYEGRASS	1	40 LB.
	WHEAT	3	120 LB.(2 BUSHEL)
	TALL FESCUE	1	40 LB.
NOV. 1 TO SPRING SEEDING	ANNUAL RYEGRASS	1	40 LB.
	PERENNIAL RYEGRASS	1	40 LB.
	TALL FESCUE	1	40 LB.
	ANNUAL RYEGRASS	1	40 LB.
	ANNUAL RYEGRASS	1.25	40 LB.
	PERENNIAL RYEGRASS	3.25	40 LB.
NOV. 1 TO SPRING SEEDING	CREeping RED FESCUE	0.4	40 LB.
	KENTUCKY BLUEGRASS	0.4	40 LB.
	KENTUCKY BLUEGRASS	0.4	40 LB.

NOTE: OTHER APPROVED SEED SPECIES MAY BE SUBSTITUTED.

TEMPORARY MULCHING RATES

STRAW	STRAW SHALL BE UNROTTED SMALL GRAIN STRAW APPLIED AT THE RATE OF 2 TONS/AC. OR 90 LB./1,000 SQ. FT. (TWO TO THREE BALES). THE STRAW MULCH SHALL BE SPREAD UNIFORMLY BY HAND OR MECHANICALLY SO THE SOIL SURFACE IS COVERED. FOR UNIFORM DISTRIBUTION OF HAND-SPREAD MULCH, DIVIDE AREA INTO APPROXIMATELY 1,000 SQ.FT. SECTIONS AND PLACE TWO 45-LB. BALES OF STRAW IN EACH SECTION.
HYDROSEEDERS	WOOD CELLULOSE FIBER SHOULD BE USED AT 2,000 LB./AC. OR 46 LB./1,000 SQ. FT.
OTHER	ACCEPTABLE MULCHES INCLUDE MULCH MATTINGS AND ROLLED EROSION CONTROL PRODUCTS APPLIED ACCORDING TO MANUFACTURER'S RECOMMENDATIONS OR WOOD MULCH/CHIPS APPLIED AT 10-20 TONS/AC.

PERMANENT SEEDING

SEED MIX	LB./ACRE	LB./1,000 ² FT.	NOTES
KENTUCKY BLUEGRASS	100-120	2	
PERENNIAL RYEGRASS		2	
KENTUCKY BLUEGRASS	100-120	2	FOR SHADED AREAS
CREeping RED FESCUE		1-1/2	

NOTE: OTHER APPROVED SEED SPECIES MAY BE SUBSTITUTED.

SEDIMENT AND EROSION CONTROL NOTES

MAINTENANCE: It is the Contractor's responsibility to maintain the sedimentation and erosion control features on this project. Any sediment or debris which has reduced the efficiency of a control shall be removed immediately. Should a structure or feature become damaged, the Contractor shall repair or replace at no additional cost to the Owner.

INSPECTIONS: The NPDES permit holder along with the Contractor shall provide qualified personnel to conduct site inspections ensuring proper functionality of the erosion and sedimentation controls. All erosion and sedimentation controls are to be inspected once per every seven calendar days and within 24 hours of a 0.5" storm event or greater that occurs over a 24 hour period. Records of the site inspections shall be kept and made available to jurisdictional agencies if requested.

CONTRACTORS RESPONSIBILITIES: Details have been provided on the plans in an effort to help the Contractor provide erosion and sedimentation control. The details shown on the plan shall be considered a minimum. Additional or alternate details may be found in the Ohio's Rainwater and Land Development Manual. The Contractor shall be solely responsible for providing necessary and adequate measures for proper control of erosion and sediment runoff from the site along with proper maintenance and inspection in compliance with the NPDES General Permit for Storm Discharges Associated with Construction Activity.

The Contractor shall provide a schedule of operations to the Owner. The schedule should include a sequence of the placement of the sedimentation and erosion control measures that provides for continual protection of the site throughout the earth moving activities.

Prior to construction operations in a particular area, all sedimentation and erosion control features shall be in place. Field adjustments with respect to locations and dimensions may be made by the Engineer, City of Dublin and the Ohio EPA.

The Contractor shall place inlet protection for the sedimentation control immediately after construction of the catch basins or inlets.

It may become necessary to remove portions of sedimentation controls during construction to facilitate the grading operations in certain areas. However, the controls shall be replaced upon grading or during any inclement weather.

The Contractor shall be responsible to have the current Storm Water Pollution Prevention Plan immediately available or posted on site.

The contractor is responsible for ensuring that offsite soil borrow and export areas have Ohio EPA NPDES permit coverage and that appropriate erosion and sediment controls are properly installed and maintained.

Street cleaning (on an as-needed basis) is required through the duration of this construction project. This includes sweeping, power cleaning and (if necessary) manual removal of dirt or mud in the street gutters.

The Contractor shall be responsible to ensure that no solid or liquid waste is discharged into storm water runoff. Untreated sediment-laden runoff shall not flow off of site without being directed through a control practice.

Direct discharge of sediment laden water to the City's sewer system or a receiving stream is a violation of Ohio EPA and City of Dublin regulation; the Contractor will be held liable for the violation and subsequent fines.

The cost for temporary channels, sediment dams, sediment basins, and other appurtenant earth moving operations shall be included in the price bid for erosion and sedimentation control quantities.

This plan must be posted on-site. A copy of the SWPPP plan and the approved EPA Stormwater Permit (with the site-specific NOI number) shall be kept on-site at all times.

PERMANENT AND TEMPORARY SEEDING

The limits of seeding and mulching are as shown within the plan as indicated by the limits of disturbance. All areas not designated to be seeded shall remain under natural ground cover. Those areas disturbed outside the seeding limits shall be seeded and mulched at the Contractor's expense.

Seeding Provided per Item 659

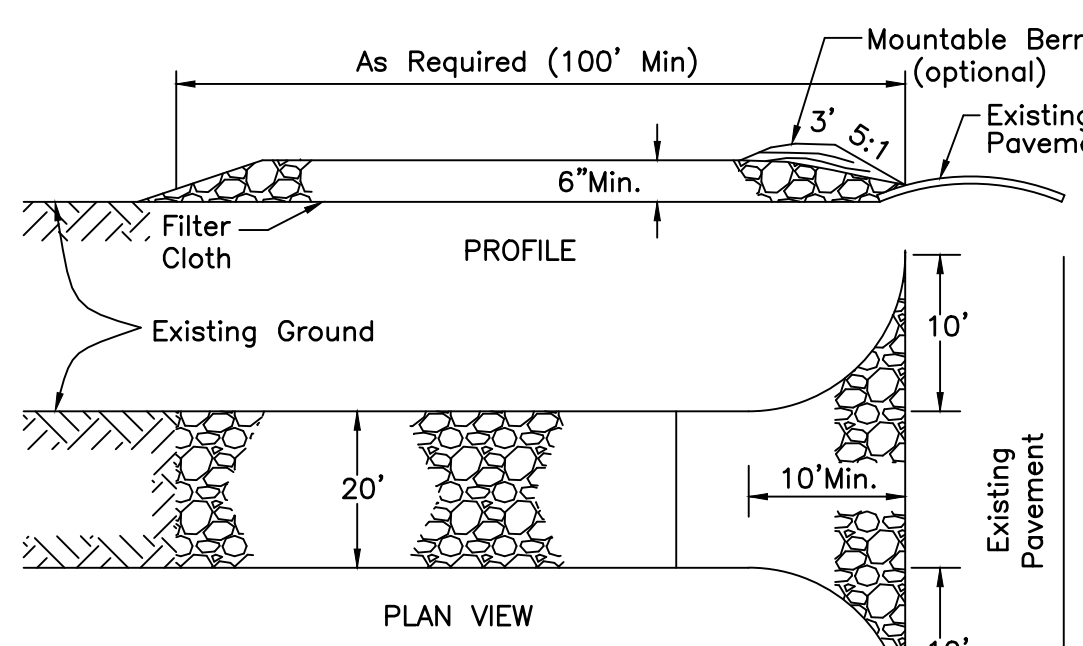

TEMPORARY CONSTRUCTION ENTRANCE

Not to Scale

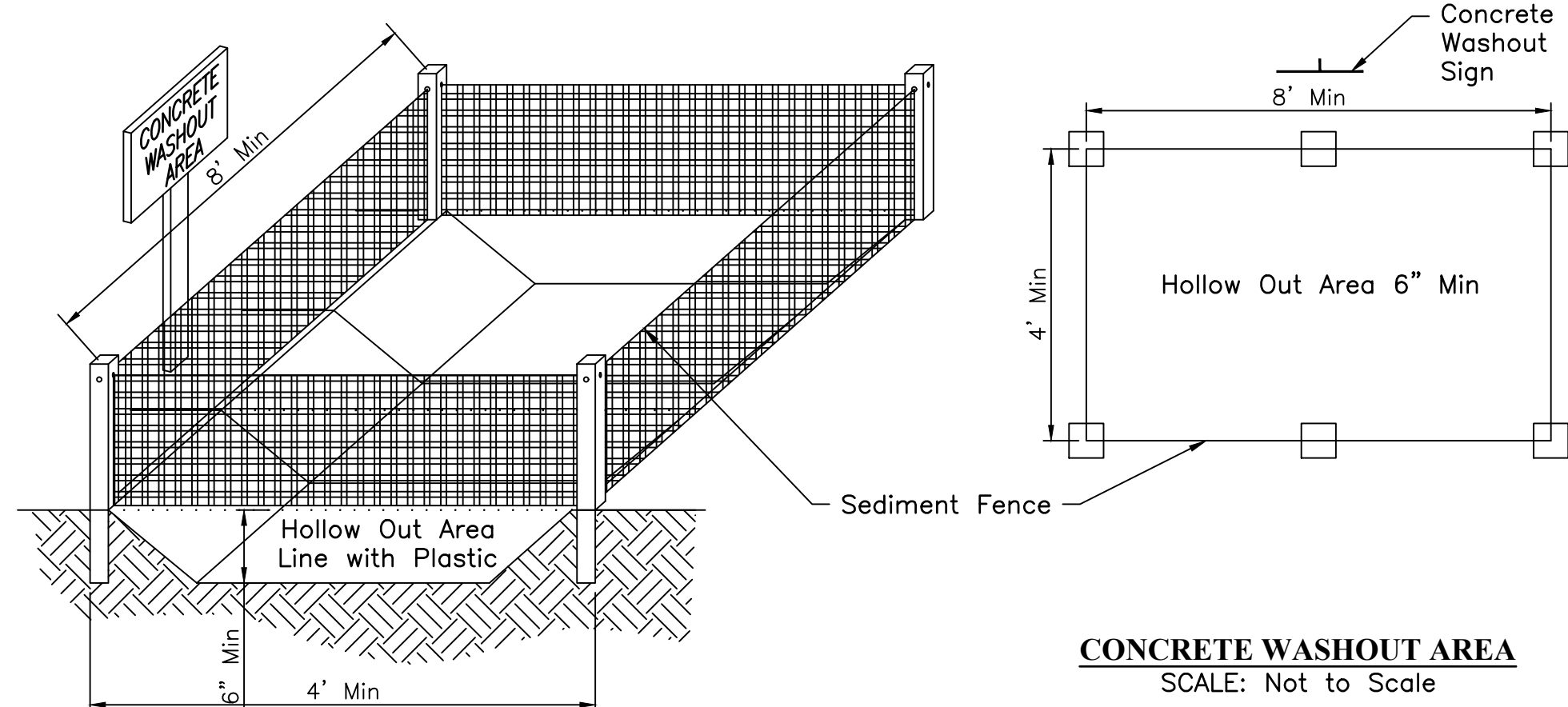

CONCRETE WASHOUT AREA

SCALE: Not to Scale

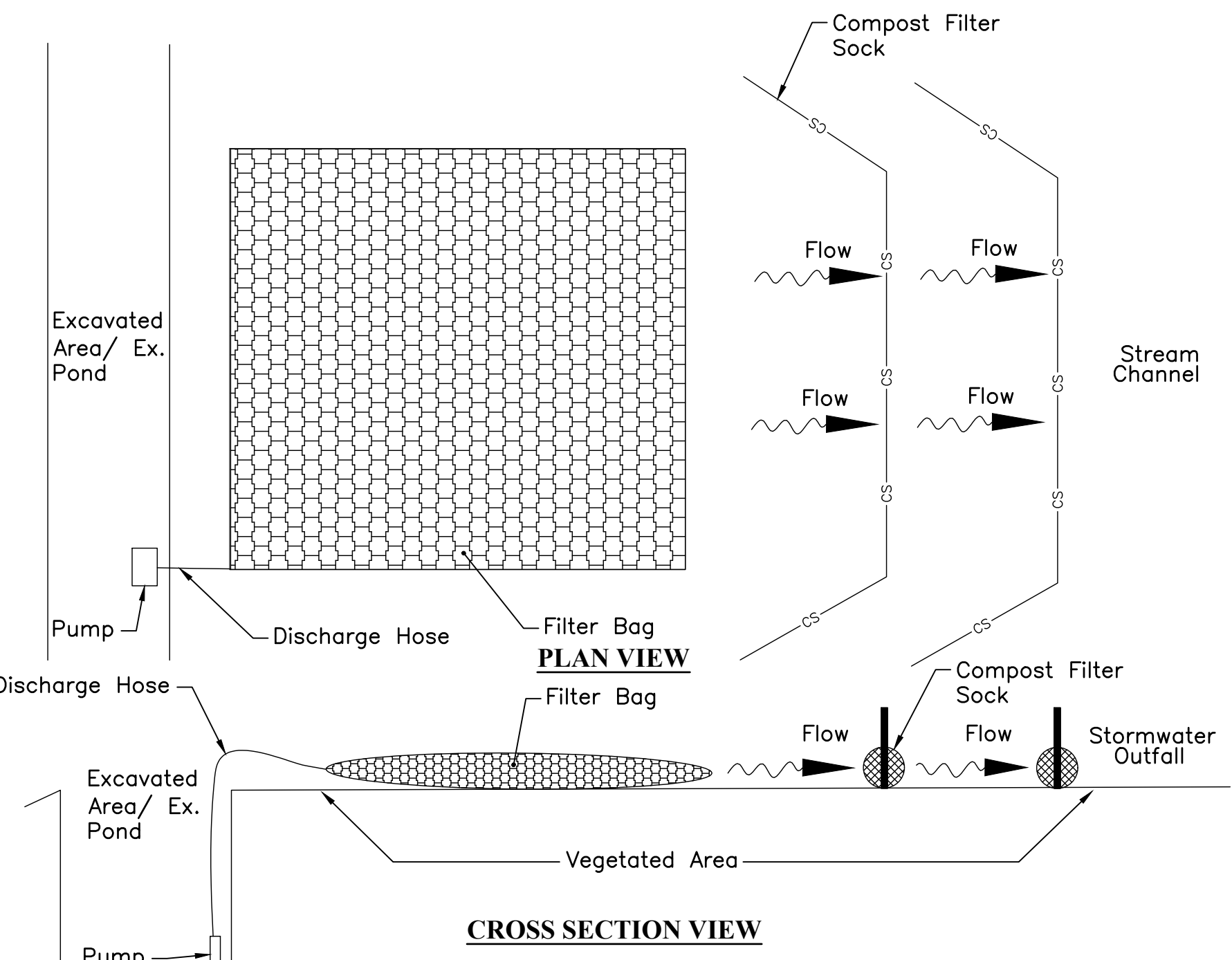

INSTALLATION: The Contractor shall pump muddy water encountered within excavated areas into a filter fabric bag. The bag shall be placed within a level undisturbed area as far away from the stormwater outfall as possible. Perimeter controls such as compost filter socks shall be utilized along the downstream side of the bag. The perimeter controls shall be installed to ensure that the water flowing out of the bag does not flow around the ends of the controls, upon completion, the bag shall be removed to an area away from the stormwater outfall and opened. The accumulated sediment shall be spread out to allow to dry and stabilized with vegetation. Filterbag shall be sized for pump rate.

MAINTENANCE: The filter bag shall be replaced when the bag is half filled with sediment.

The Contractor shall contact the Owner/Engineer for consultative services if dewatering activities overwhelm the filter bag and perimeter controls.

DEWATERING FILTER BAG

Not to Scale

CONSTRUCTION SPECIFICATION NOTES

1. Stone Size - Use 2" stone, or reclaimed or recycled concrete equivalent.
2. Length - One-Hundred (100) foot minimum.
3. Thickness - Not less than six (6) inches.
4. Width - Twenty (20) foot minimum, but not less than the full width at points where ingress or egress occurs.
5. Geotextile - will be placed over the entire area prior to placing of stone.
6. Surface Water - All surface water flowing or diverted toward construction entrances shall be piped across the entrance. If piping is impractical, a mountable berm with 5:1 slopes will be permitted. Cost of pipe shall be included in the price bid for the Stabilized Construction Entrance.
7. Maintenance - The entrance shall be maintained in a condition which will prevent tracking or flowing of sediment onto public right-of-way. This may require periodic top dressing with additional stone as conditions demand and repair and/or cleanout of any measures used to trap sediment. All sediment spilled, dropped, washed or tracked onto public rights-of-way must be removed immediately.
8. Washing - Wheels shall be cleaned to remove sediment prior to entrance onto public right-of-ways. When washing is required, it shall be done on an area stabilized with stone and which drains into an approved sediment trapping device. The Contractor's bid shall include costs associated with manning and operating the wheel wash station.
9. Periodic inspection and needed maintenance shall be provided after each rain.

Notes:

1. Concrete trucks shall utilize areas to washout trucks.
2. Accumulated concrete shall be removed from the site and disposed of properly.
3. The cost associated with excavating, placement of fence, maintaining and removing the concrete washout area shall be included in the price bid for Item 207 - Concrete Washout Area for the project. A quantity of 1 Each has been carried to the General Summary.
4. As an alternative, contractor shall use a roll off box with liner.

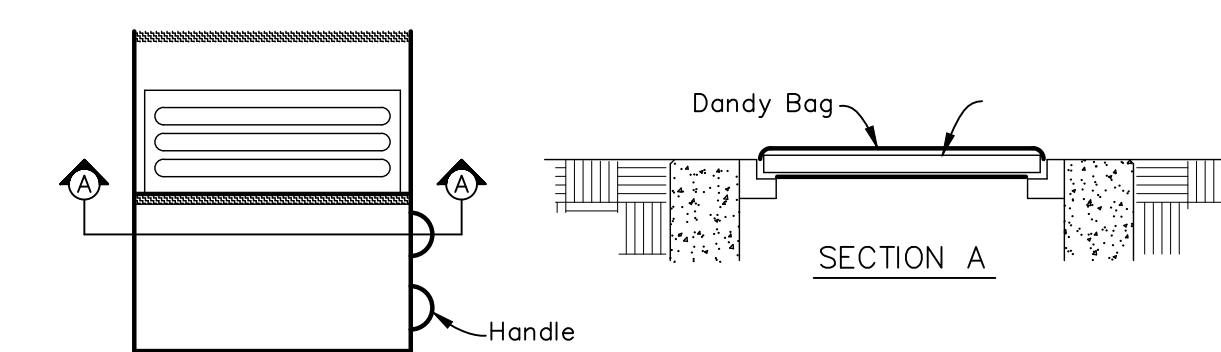

INSTALLATION:

Stand grate on end. Place Dandy Bag over grate. Roll grate over so that open end is up. Pull up slack. Tuck flap in. Be sure end of grate is completely covered by flap or Dandy Bag will not fit properly. Holding handles, carefully place Dandy Bag with grate inserted into catch basin frame so that red dot on the top of the Dandy Bag is visible.

MAINTENANCE:

With a stiff bristle broom or square point shovel remove silt & other debris off surface after each event.

DANDY BAG SEDIMENT FILTER DETAIL

Not To Scale

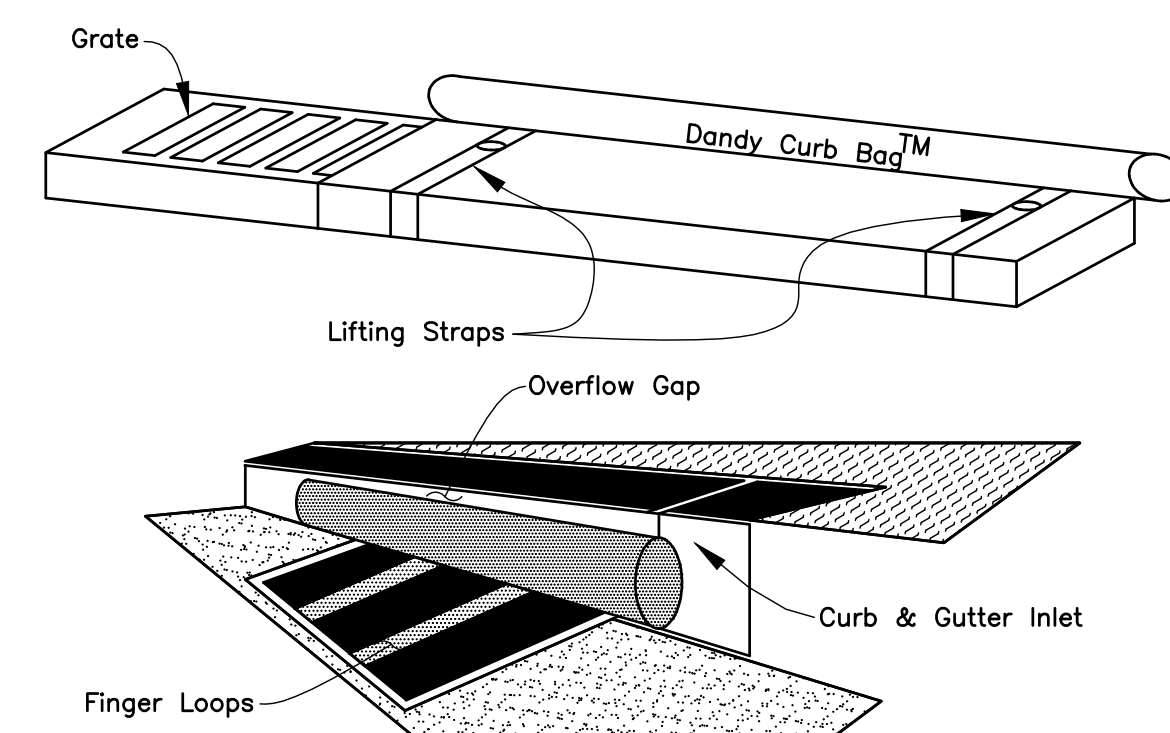

DANDY CURB BAG DETAIL

Not To Scale

Installation:

Stand Grate on End. Slide the Dandy Curb Bag on with Dam on Top of the Grate. Pull all Excess Down. Lay Unit on its side. Carefully Tuck Flap in. Press Velcro Strips Together. Install the Unit Making Sure Front Edge of Grate is Inserted in. Frame First then Lower Back into Place. Press Velcro Dots Together which are Located Under Lifting Straps. This Insures Straps Remain Flush with Gutter.

Maintenance:

With a Stiff Bristle Broom Sweep Silt and Other Debris off Surface After Each Event.

SEDIMENT FENCE:

This sediment barrier utilizes standard strength or extra strength synthetic filter fabrics. It is designed for situations in which only sheet or overland flows are expected. Material Properties are listed in the provided table.

1. The height of a silt fence shall not exceed 36-inches (higher fences may impound volumes of water sufficient to cause failure of the structure).
2. The filter fabric shall be purchased in a continuous roll cut to the length of the barrier to avoid the use of joints. When joints are necessary, filter cloth shall be spliced together only at a support post, with a minimum of 6 inch overlap, and securely secured.
3. Posts shall be spaced a maximum of 10 feet apart at the barrier location and driven securely into the ground (minimum of 12-inches). Wood posts will be a minimum of 3/2" long when extra strength fabric is used without the wire support fence, post spacing shall not exceed 6 feet.
4. A trench shall be excavated approximately 4-inches wide and 6-inches deep along the line of posts and upslope from the barrier.
5. When standard strength filter fabric is used, a wire mesh support fence shall be fastened securely to the upslope side of the posts using heavy duty wire staples at least 1-inch long, tie wires or hog rings. The wire shall extend into the trench a minimum of 2-inches and shall not extend more than 36-inches above the original ground surface.
6. The standard strength filter fabric shall be stapled or wired to the fence, and 8-inches of the fabric shall be extended into the trench. The fabric shall not extend more than 36-inches above the original ground surface. Filter fabric shall not be stapled to existing trees.
7. When extra strength filter fabric and closer post spacing are used, the wire mesh support fence may be eliminated. In such a case, the filter fabric is stapled or wired directly to the posts with all other provisions of Item No. 6 applying.
8. The trench shall be backfilled and soil compacted over the filter fabric.
9. Silt fences shall be removed when they have served their useful purpose, but not before the upslope area has been permanently stabilized.
10. To prevent water ponded by the silt fence from flowing around the ends, each end shall be constructed upslope so that the ends are at a higher elevation.

MAINTENANCE:

Silt fences and filter barriers shall be inspected immediately after each rainfall and at least daily during prolonged rainfall. Sediment deposits should be removed after each storm event.

Any required repairs shall be made should the fabric on a silt fence or filter barrier decompose or become ineffective prior to the end of the expected usable life.

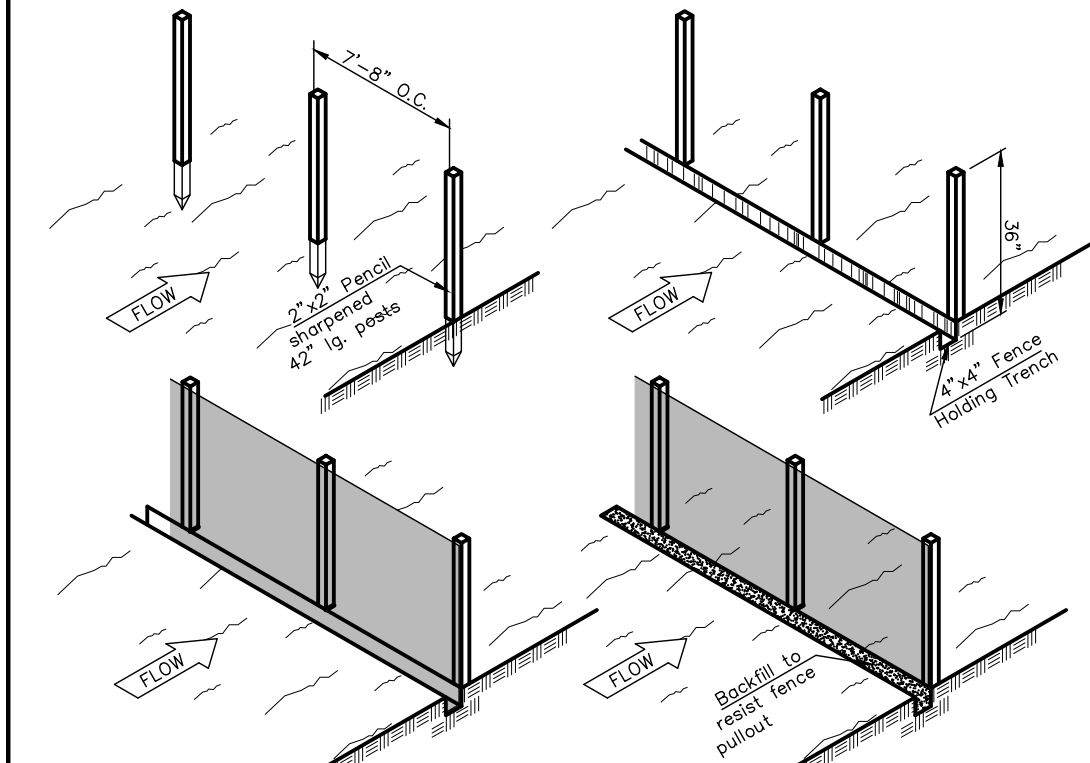

MATERIAL PROPERTIES	VALUES	TEST METHOD
Grab Tensile Strength	90 lb. Minimum	ASTM 1682
Mullen Burst Strength	190 psi Minimum	ASTM 3786
Slurry Flow Rate	0.3 gal./min./ft ² Maximum	
Equivalent Opening Size	40-80	U.S. Std. Siew CW-02215
Ultraviolet Radiation Stability	90% Minimum	ASTM-G-26

GWG3
ARCHITECTURE, PLLC

600 Main Street
Suite 300
North Little Rock, AR 72114
Phone: 501-758-7443

www.taggarch.com

FINAL DEVELOPMENT PLAN
NOT FOR CONSTRUCTION

EMHT
Evans, Mechwart, Hambleton & Tilton, Inc.
Engineers + Surveyors + Planners + Scientists
5500 New Albany Road, Columbus, OH 43054
Phone: 614.775.4500 | Toll Free: 888.775.3448
emht.com

Select MEDICAL

NEUROLOGICAL TRANSITIONAL CENTER

DUBLIN, OH

PROJECT NAME _____

SEAL _____

REVISIONS _____

NO.	DESCRIPTION	DATE

EROSION SEDIMENT CONTROL NOTES & DETAILS

SHEET NAME _____

DATE October 19, 2022

PROJECT NUMBER 20220237

C0.8

SHEET NUMBER _____

A:\2022\20237\DWG\045\Sheets\Plan Set\20220337 Erosion Sediment Control Plan.dwg, Last Saved By: pschoeffler, 10/19/2022 9:01 AM, Last Printed By: pschoeffler, 10/19/2022 9:29 AM (No Xrefs)

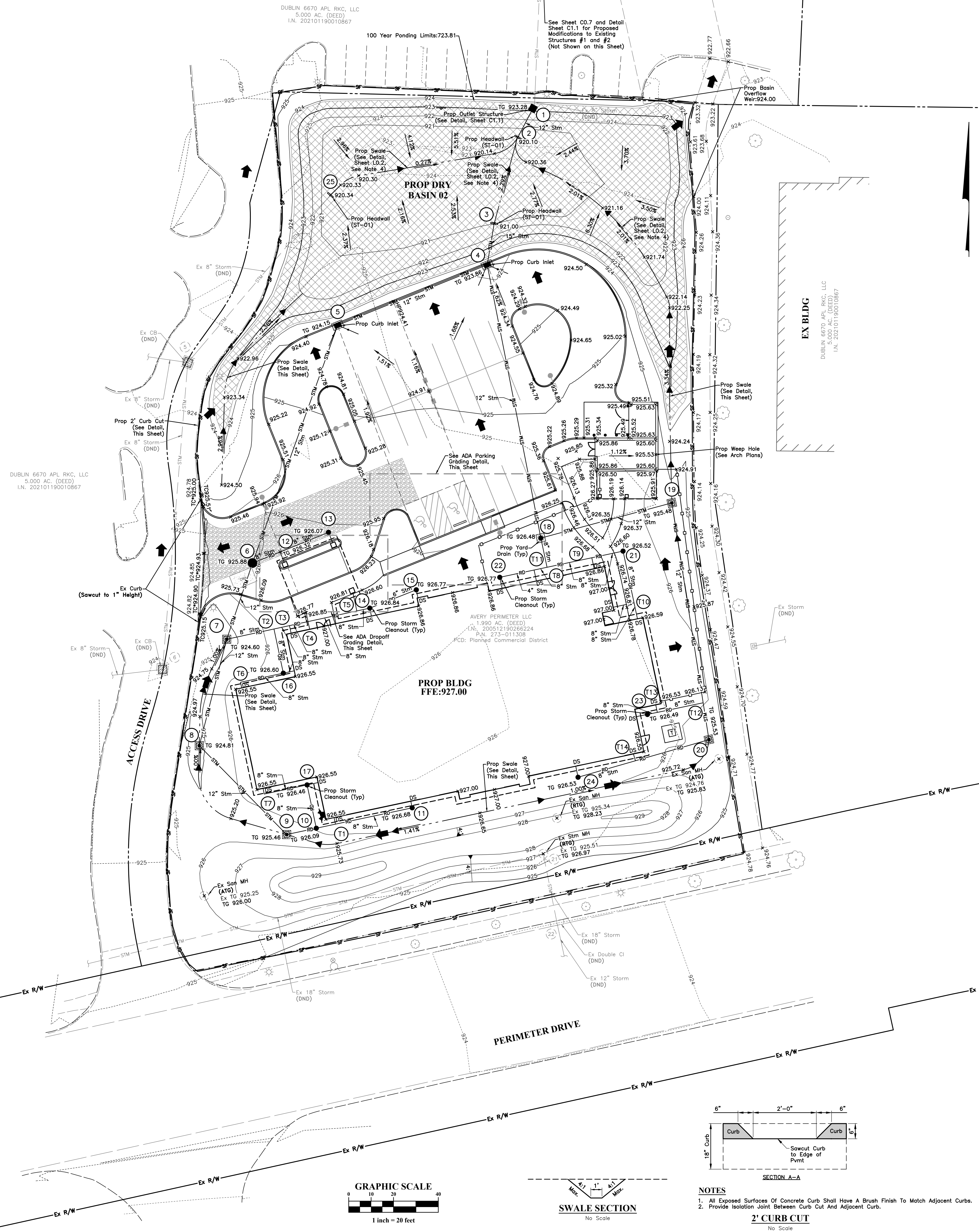

NOTES:

1. Prior to construction operations in a particular area, all sedimentation and erosion control features shall be in place.
 2. The Contractor shall be solely responsible for providing the necessary and adequate measures for proper control of the erosion and sediment runoff from the site along with proper maintenance and inspection in compliance with the NPDES General Permit for Storm Discharges Associated with Construction Activity.
 3. The Contractor shall install additional control measure and make field adjustments throughout the duration of the project as directed by the Engineer, City of Dublin of the Ohio EPA.
 4. The decorative stone swale has been shown based on various discussion with Dublin staff. Dublin staff has indicated that the intent/desire is for swale to drain basin completely (to avoid standing water/moss/algae area) and the developer and design engineer agree/store the same intent/desire. The design engineer has noted, "due to the need for project to intercept and connect to the existing storm sewer piping that was previously permitted (by others) and approved by the City, there are NO options to increase this swales slope beyond the 0.27% proposed." The design engineer has also noted that a concrete swale would provide the most positive drainage results. Design engineer has illustrated a decorative stone swale instead of concrete swale based on discussions with the City's planning department (adjustment was made/requested due to aesthetic purposes).
- The decorative stone section (and 2%+ basin side slopes) design intent is to promote infiltration. Decorative stone swales are typically specified to include an underdrain, but due to the existing pipe elevations, an underdrain is unable to be proposed for this project. If the decorative stone swale is not operating as intended, the developer commits to submitting a plan revision to Dublin for an alternative option to be approved and constructed (i.e. concrete swale, modified landscaping, etc.).

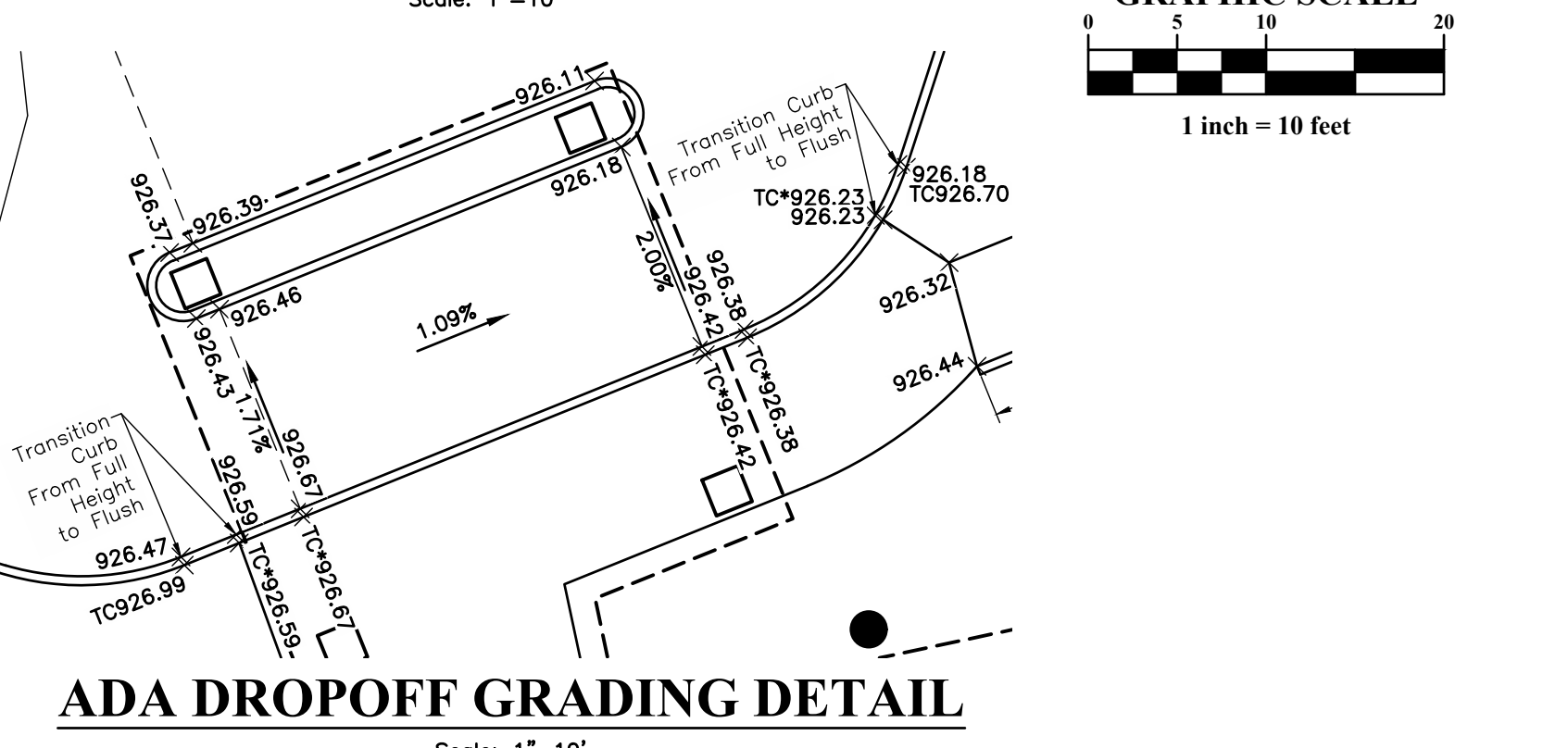
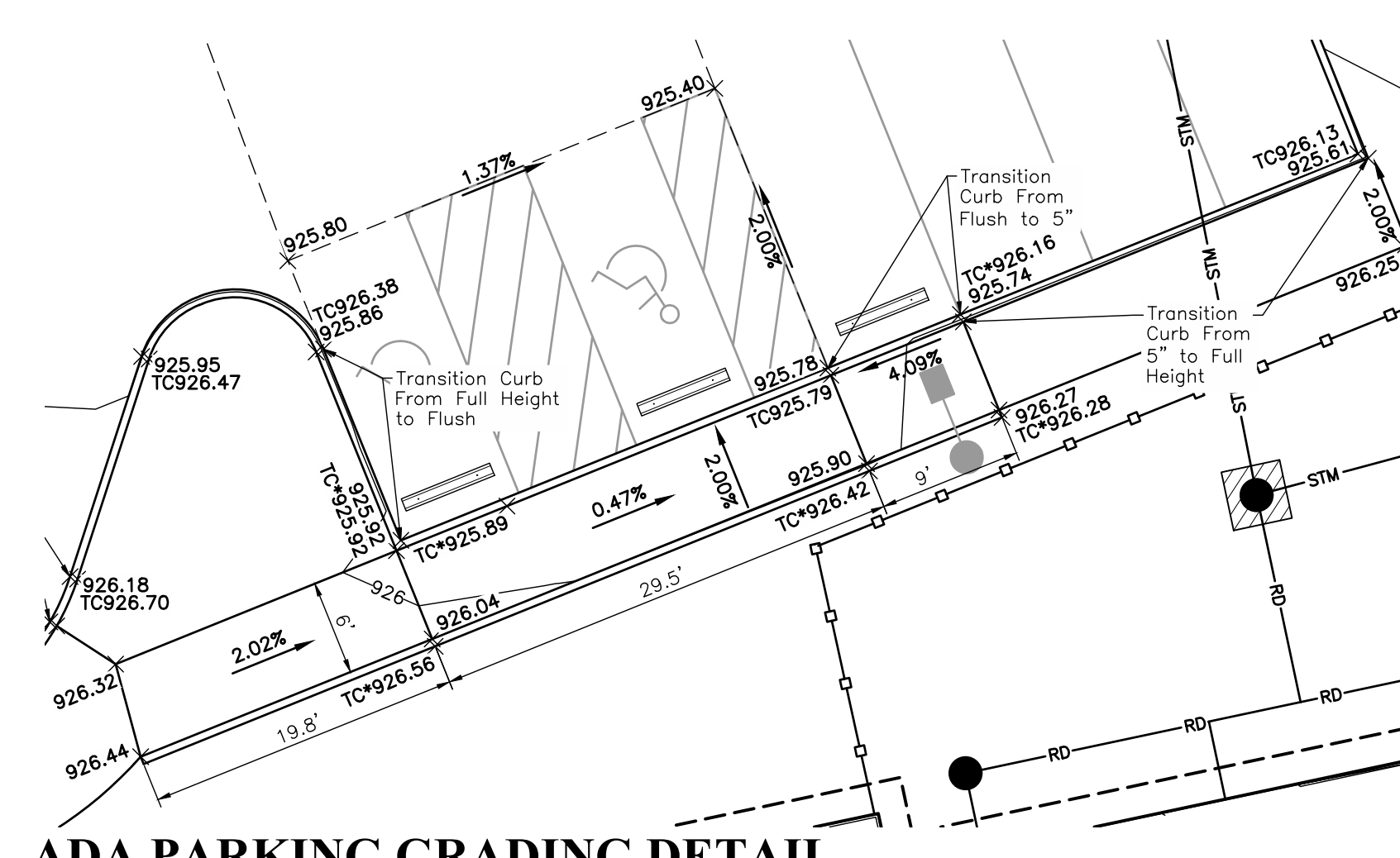

Storm Event (Recurrence Interval)	Peak Inflow Rates (cfs)	Basin 02 Proposed Release Rates (cfs)	Maximum W.S.E., T.O.B. = 924.00 (feet)	Storage Volume Utilized (cu-ft)
1	4.30	0.31	921.97	8,972.62
2	5.38	0.32	922.27	11,899.98
5	6.66	0.31	922.68	16,389.15
10	7.67	0.30	923.01	20,232.89
25	9.05	0.30	923.40	25,334.77
50	10.21	0.30	923.61	28,248.38
100	11.49	0.34	923.81	31,382.50

DRY BASIN 02 DATA TABLE

LEGEND	
	Flood Routing Arrow
	Flow Arrow
	Existing Contours
	Proposed Contours
	Prop Downspout Connection (See Detail, Sheet C0.4)
	Top of Walk/Finished Grade
	Top of Rim/Grate
	Top of Curb
	Curb Reveal Varies/Not Full Height
	Limits of Disturbance
	Compost Filter Sock (See Detail, Sheet C0.8)
	Stabilized Construction Entrance (See COC Std Dwg 2230)
	Concrete Washout Area (See Detail, Sheet C0.8)
	Dandy Bag and Dandy Curb Bag Inlet Protection (See Detail, Sheet C0.8)

- NOTES**
1. All Exposed Surfaces Of Concrete Curb Shall Have A Brush Finish To Match Adjacent Curbs.
 2. Provide Isolation Joint Between Curb Cut And Adjacent Curb.
- 2' CURB CUT**
 No Scale



600 Main Street
 Suite 300
 North Little Rock, AR 72114
 Phone: 501-758-7443

www.taggarch.com

**FINAL DEVELOPMENT PLAN
 NOT FOR CONSTRUCTION**



NEUROLOGICAL TRANSITIONAL CENTER

DUBLIN, OH

PROJECT NAME _____

SEAL _____

REVISIONS _____

NO.	DESCRIPTION	DATE

EROSION SEDIMENT CONTROL PLAN

SHEET NAME _____

DATE October 19, 2022

PROJECT NUMBER 20220337

C0.9
 SHEET NUMBER

U:\20220237\DWG\45Sheets\Plan Set\20220237 Storm Profiles.dwg, Last Saved By: pschoeffe, 10/19/2022 9:20 AM Last Printed By: Schoeffe, Phillip, 10/19/2022 9:30 AM (No Xrefs)

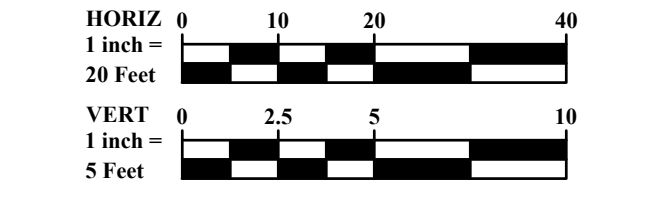
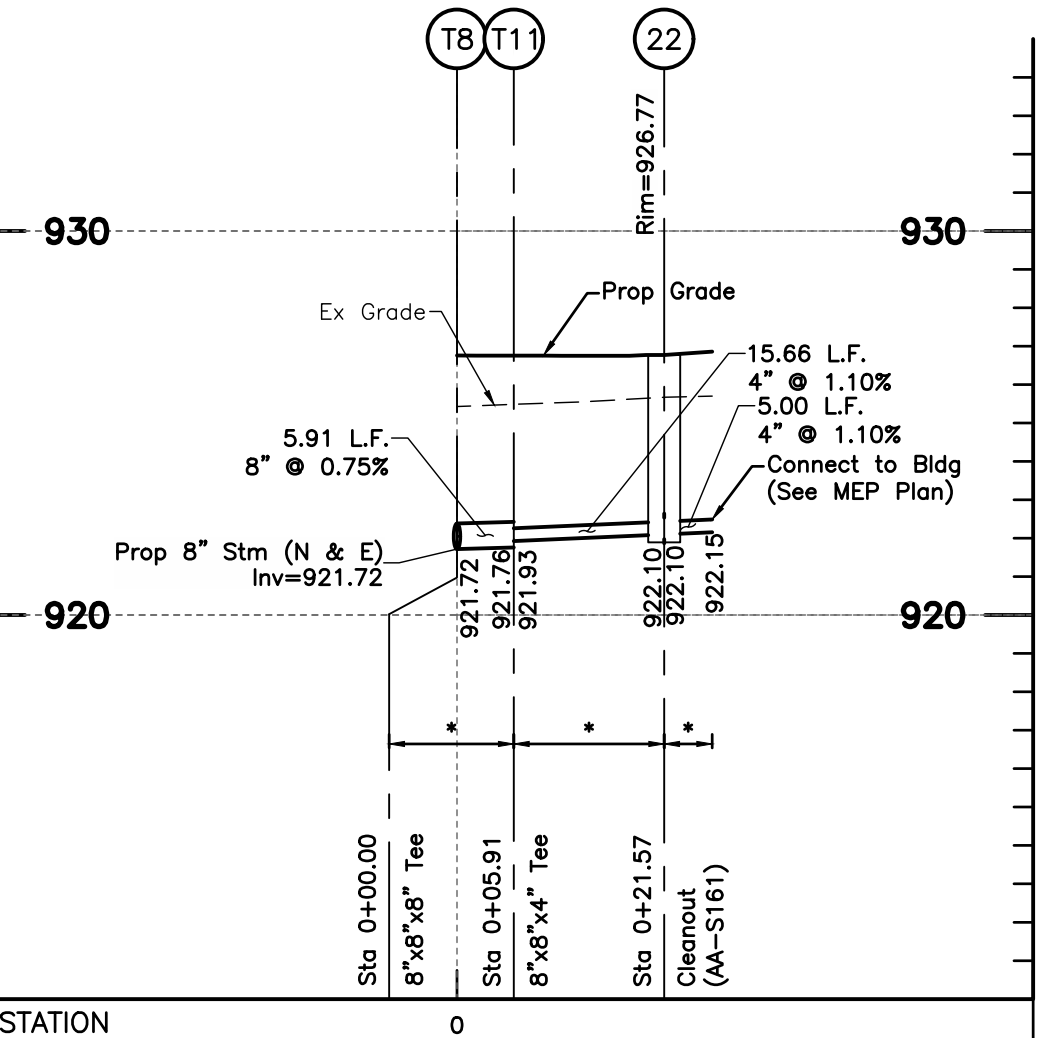
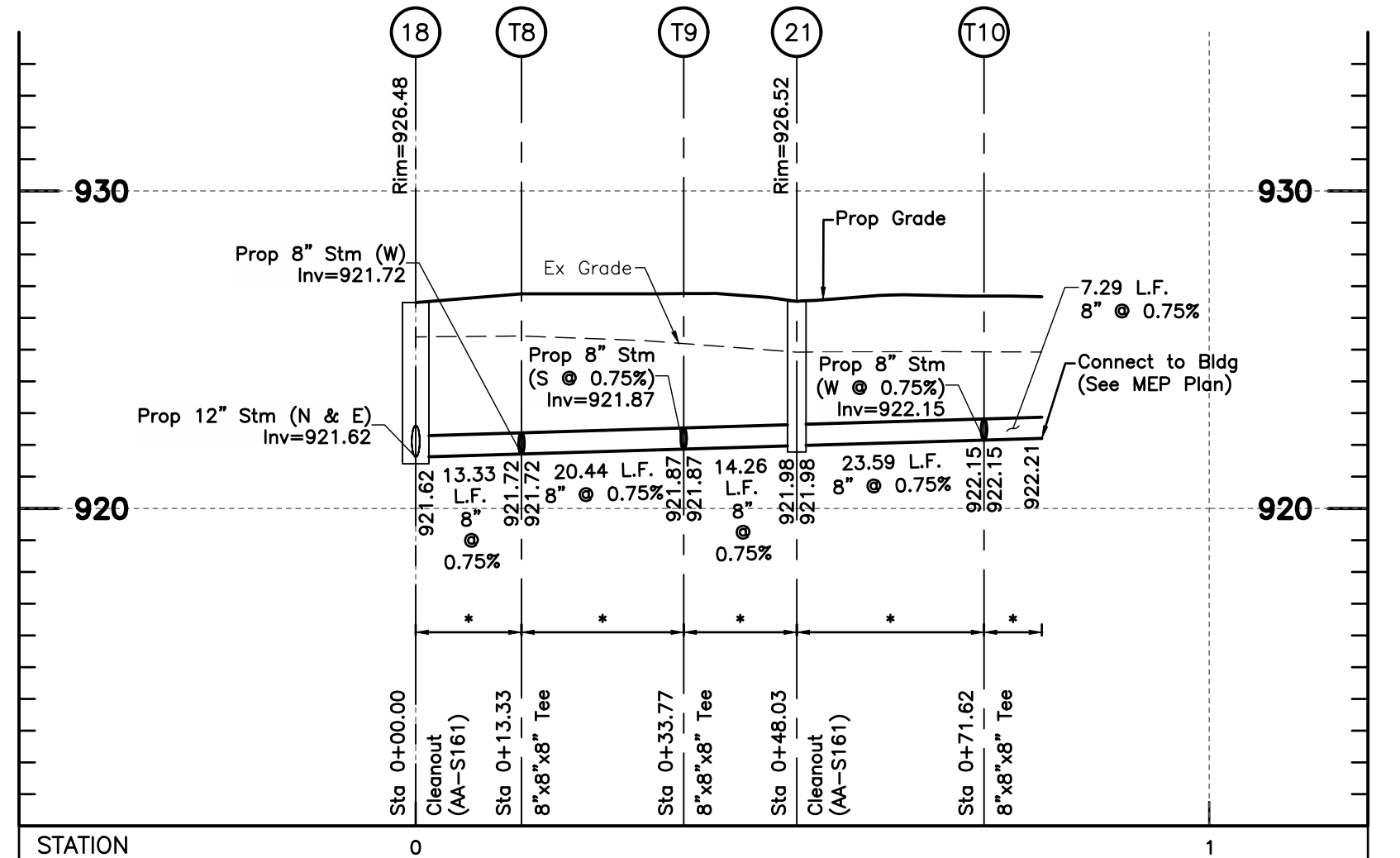
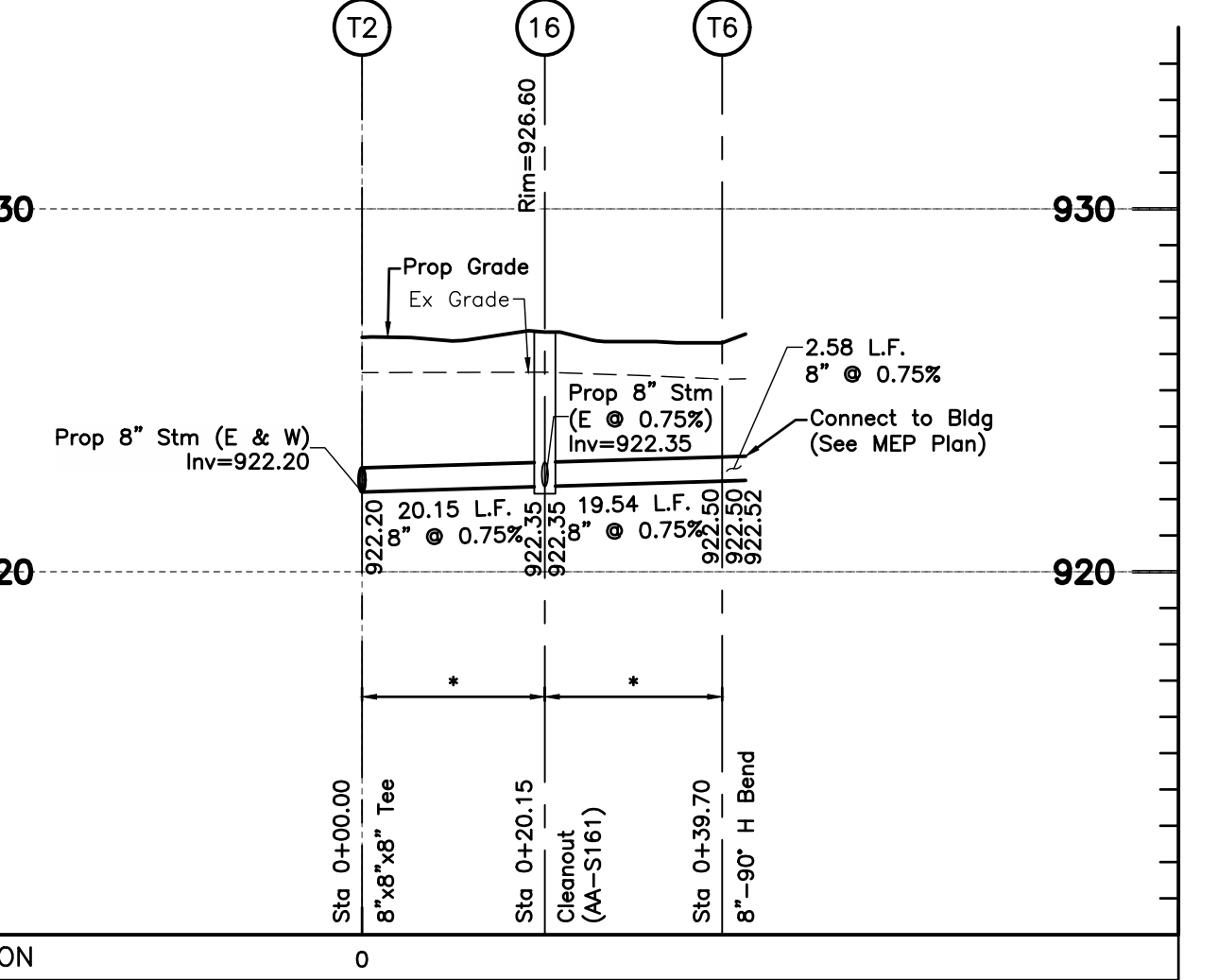
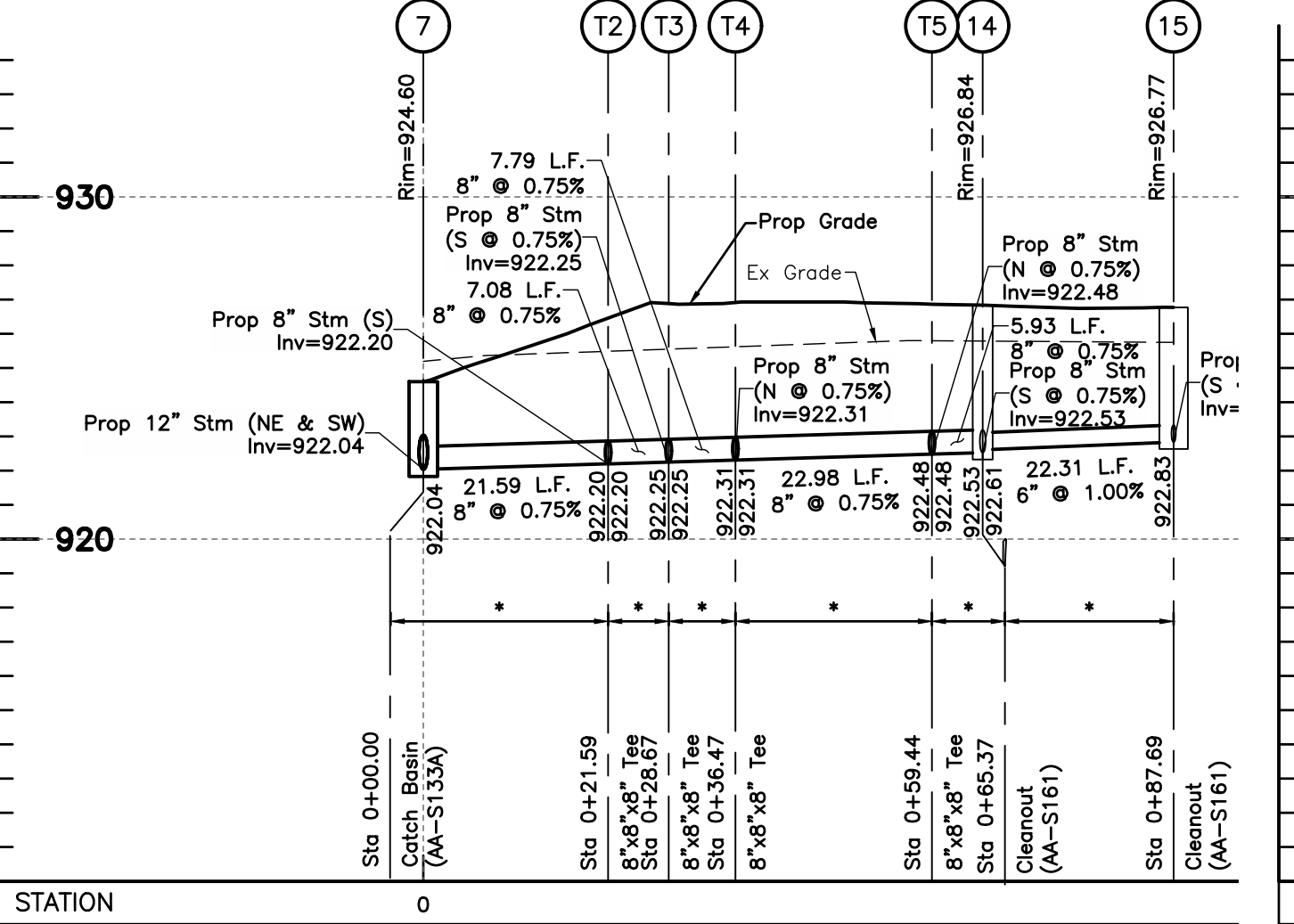
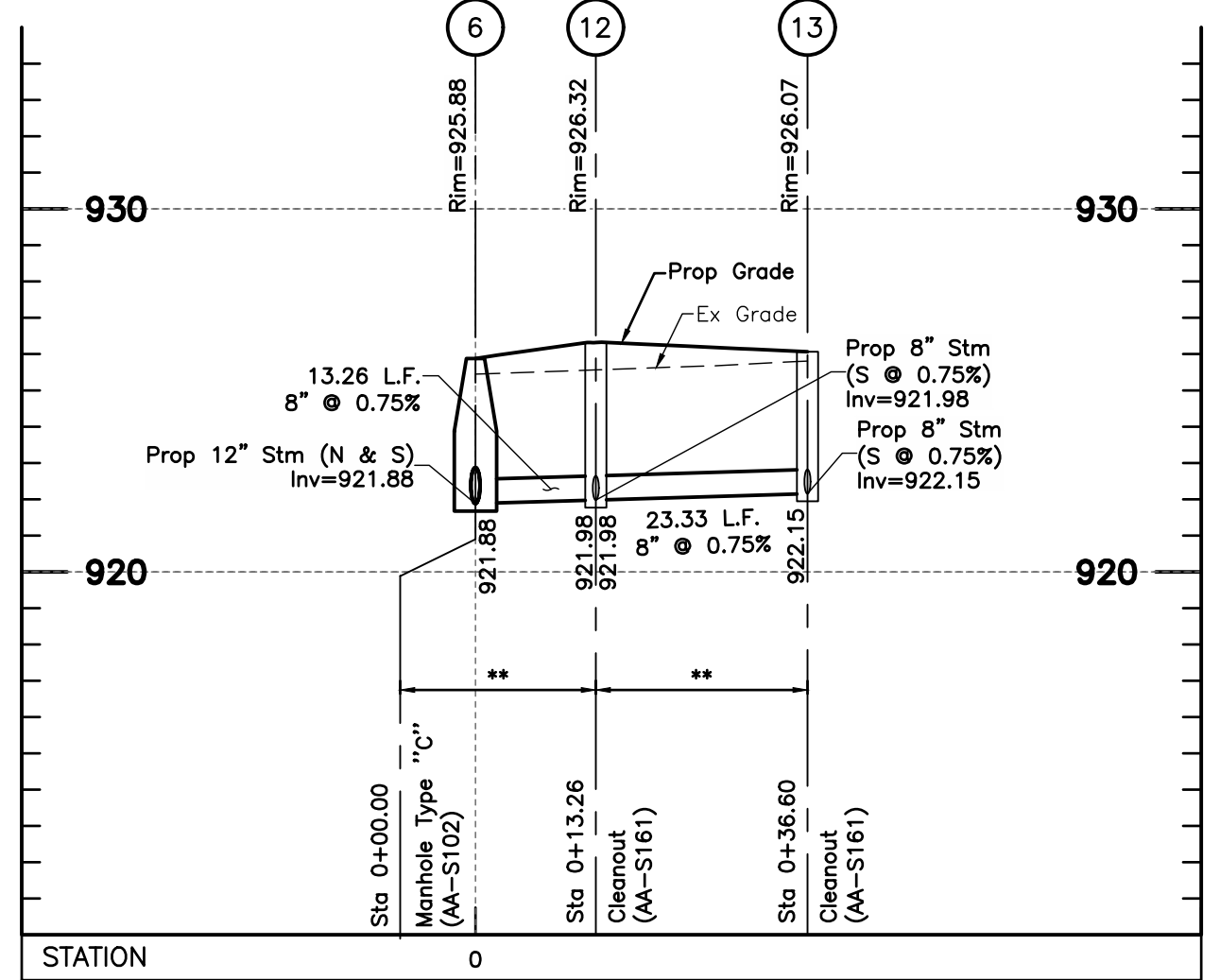
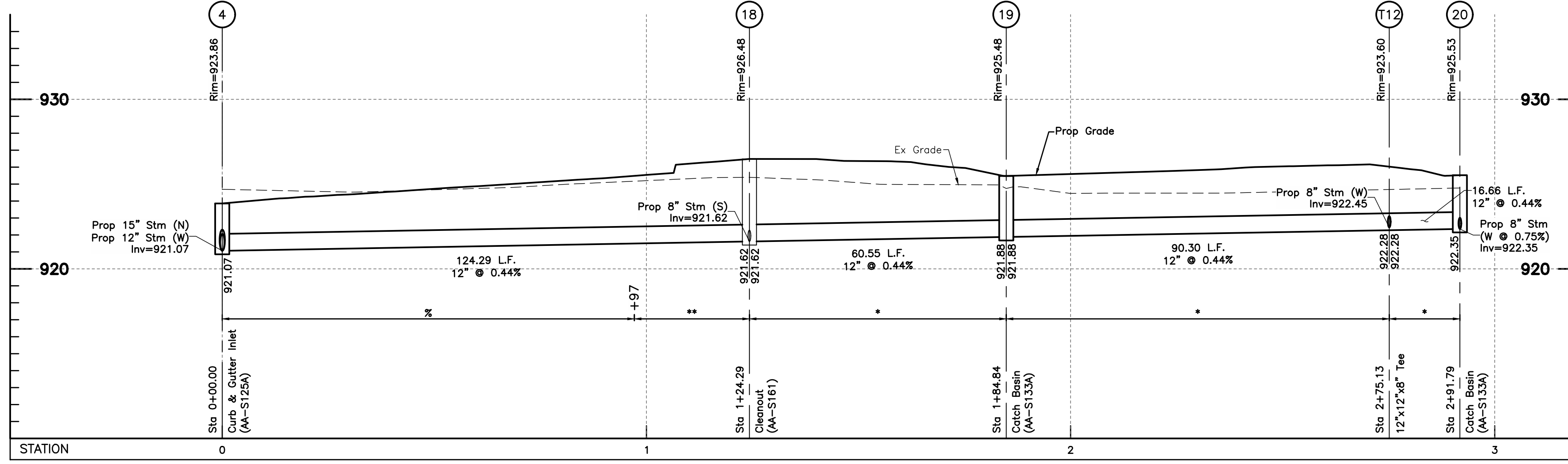
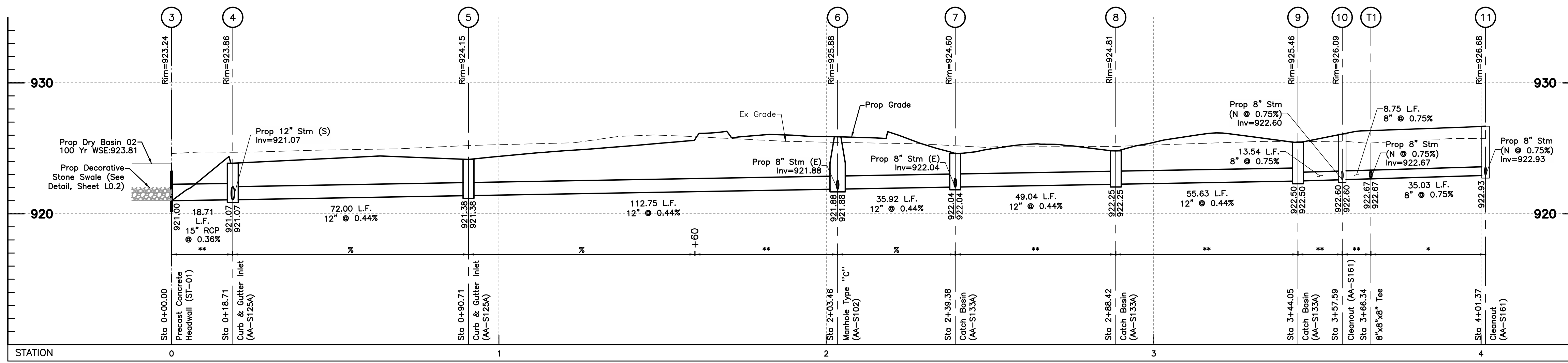

STRUCTURE COORDINATES			
STRUCTURE #	NORTHING - PLAN	EASTING - PLAN	EASTING - AS BUILT
T8	767591.0035	1782283.0478	
T11	767589.7747	1782277.2667	
T9	767595.2526	1782303.0382	
T10	767575.1394	1782321.8924	
T2	767563.4578	1782161.1310	
T3	767564.9637	1782168.0525	
T4	767566.6205	1782175.6677	
T13	767526.2348	1782332.2874	
T5	767571.5335	1782198.1156	
T6	767539.8811	1782146.2067	
T7	767489.7956	1782156.8102	
T14	767504.6420	1782332.4992	
T12	767530.5244	1782352.7478	
T1	767476.3492	1782188.5920	
1	767795.7943	1782276.7426	
2	767782.9337	1782270.0313	
3	767744.4571	1782259.4510	
4	767726.0031	1782256.3415	
5	767699.0314	1782189.5843	
6	767592.8878	1782151.5605	
7	767588.8681	1782140.0359	
8	767511.3800	1782127.7890	
9	767471.7154	1782166.7920	
10	767474.5300	1782180.0332	
11	767483.6326	1782222.8577	
12	767597.8567	1782163.8590	
13	767606.5975	1782185.4933	
14	767572.7656	1782203.9119	
15	767580.9286	1782224.6802	
16	767543.7441	1782165.3213	
17	767493.8586	1782175.9248	
18	767604.0427	1782280.2762	
19	767619.7317	1782338.7587	
20	767514.0658	1782355.3288	
21	767598.2175	1782316.9870	
22	767586.5182	1782261.9458	
23	767525.3093	1782327.8729	
24	767497.2954	1782296.9061	
25	767757.1257	1782186.3422	

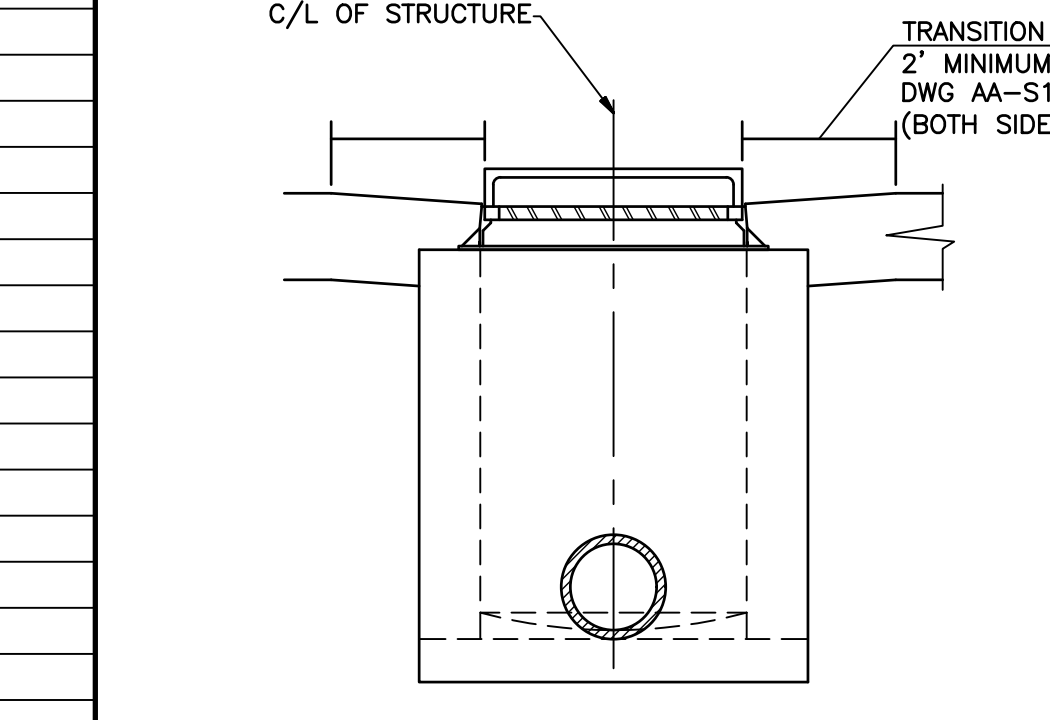
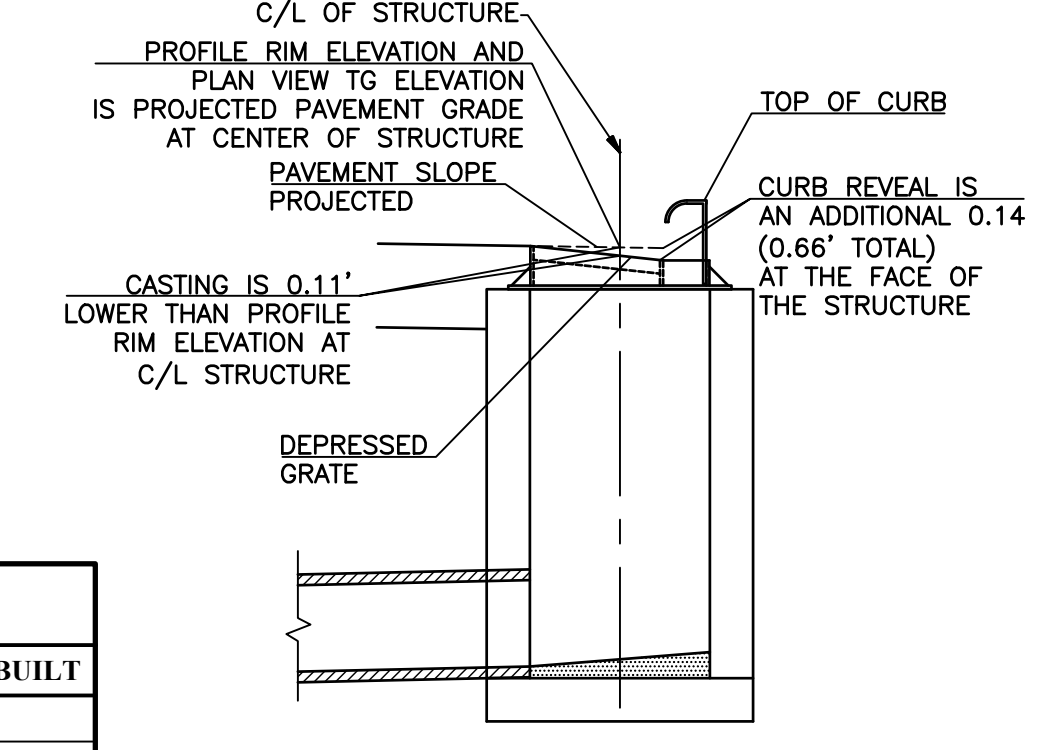

- SEE CITY OF COLUMBUS STD. DWGS. AA-S125A AA-S128 FOR ADDITIONAL INFORMATION.
- THE TOP OF BONNET SHALL BE THE SAME AS THE TOP OF CURB ELEVATION. THE EDGE OF PAVEMENT SHALL BE 3/8" HIGHER THAN THE GRATE WHENEVER THEY MEET/TOUCH.
- TYPICAL CROSS SLOPE OF PAVEMENT DOES NOT MATCH THE CROSS SLOPE OF THE CASTING. RIM ELEVATION AND TO ELEVATION ON THE PLAN IS THE PROJECTED PAVEMENT GRADE AND DOES NOT REPRESENT THE ACTUAL CASTING ELEVATION. PER STD DWG AA-S128 THE GRATE SLOPE IS 2" OVER 18". SEE DETAIL ABOVE FOR ADDITIONAL INFORMATION.

CURB & GUTTER INLET DETAIL
NOT TO SCALE

RIM = Top of Grate at Finished Grade
Backfill Shall Be Compacted To The Density Of The Adjacent Suitable Soil Unless Otherwise Noted.

- ** Compacted Backfill Per 911 & General Notes
- ** Compacted Granular Backfill, Per 912 & Gen. Notes
- % Concrete Encased w/ Compacted Granular Backfill to subgrade.
- # W/ 30" Opening, MOD, As Per Plan
- Elevation shown per interpolation of record drawings or typical assumed depth for this utility. Contractor to field verify invert and location of existing utility prior to ordering materials.
- Invert shown per site survey. Contractor to field verify invert and location of existing utility prior to ordering materials.
- + Pipe runs (denoted with "+") are to be sanitary grade (watertight) pipe and have watertight joints per City of Columbus Construction and Material Specification 901.15. This applies to full pipe length, from structure to structure.
- Trench Dams per City of Columbus Construction and Material Specification 901.11. This applies to full pipe length, from structure to structure.

All curing of existing structures for storm sewer installation shall be included in price of 901. No separate payment will be made.

All structures within sidewalk areas shall be equipped with an ADA compliant frame and casting. Payment shall be included within the price of the structure. No separate payment will be made.

The reference/staking point for all curb and gutter inlets shown on this plan are 6" in front of the face of curb, unless otherwise noted. Contractor shall reference the City of Columbus Standard Drawings to determine the center of the structures base relative to this point. Reference Curb & Gutter Detail on this sheet for additional information.

LINE	BEARING	LENGTH	SIZE
1-2	S27°33'29"W	14.51'	12"
3-4	S09°33'52"W	18.71'	15"
4-5	S68°00'00"W	72.00'	12"
4-18	S11°06'11"E	124.29'	12"
5-6	S19°42'32"W	112.75'	12"
6-7	S18°42'52"W	35.92'	12"
7-8	S14°27'40"W	49.04'	12"
7-12	N77°43'32"E	21.59'	8"
8-9	S44°31'05"E	55.63'	12"
9-10	N78°00'00"E	13.54'	8"
10-17	N12°00'00"W	19.76'	8"
10-11	N78°00'00"E	8.75'	8"
11-BLDG	N12°00'00"W	3.00'	8"
12-BLDG	S22°00'00"E	5.00'	8"
12-13	N68°00'00"E	23.33'	8"
13-BLDG	S22°00'00"E	5.00'	8"
14-BLDG	S11°29'56"E	3.61'	8"
14-15	N68°32'33"E	22.31'	6"
15-BLDG	S11°29'56"E	3.61'	8"

LINE	BEARING	LENGTH	SIZE
16-BLDG	N78°00'00"E	5.00'	8"
16-16	S78°00'00"W	19.54'	8"
17-BLDG	N78°00'00"E	5.00'	8"
18-19	N74°58'58"E	60.55'	12"
18-18	S12°00'00"E	13.33'	8"
19-112	S08°54'44"E	90.30'	12"
20-114	S73°59'02"W	34.16'	8"
21-BLDG	S12°00'00"E	23.59'	8"
22-BLDG	S12°00'00"E	5.00'	4"
22-111	N78°00'00"E	15.66'	4"
23-BLDG	S78°54'19"W	5.00'	8"
24-BLDG	N12°00'00"W	5.04'	8"
11-BLDG	N12°00'00"W	3.00'	8"
11-11	N78°00'00"E	35.03'	8"
T2-16	S12°00'00"E	20.15'	8"
T2-13	N77°43'32"E	7.08'	8"
T3-BLDG	S12°00'00"E	3.44'	8"
T3-14	N77°43'32"E	7.79'	8"
T4-BLDG	N12°00'00"W	4.33'	8"
T4-15	N77°39'17"E	22.98'	8"

LINE	BEARING	LENGTH	SIZE
T5-BLDG	N12°00'00"W	8.25'	8"
T5-14	N78°00'00"E	5.93'	8"
T6-BLDG	S12°00'00"E	2.58'	8"
T7-BLDG	N12°00'00"W	2.58'	8"
T7-17	N78°00'00"E	19.54'	8"
T8-19	N78°00'00"E	20.44'	8"
T8-111	S78°00'00"W	5.91'	8"
T9-BLDG	S12°00'00"E	5.00'	8"
T9-21	N78°00'00"E	14.26'	8"
T10-BLDG	S12°00'00"E	7.29'	8"
T10-11	S78°00'00"W	9.51'	8"
T11-BLDG	S12°00'00"E	5.00'	8"
T12-20	S08°54'44"E	16.66'	12"
T12-113	S78°09'33"W	20.91'	8"
T13-BLDG	S12°00'00"E	3.42'	8"
T13-23	S78°09'33"W	4.51'	8"
T14-BLDG	N16°00'58"W	3.18'	8"
T14-24	S73°59'02"W	26.63'	8"

FINAL DEVELOPMENT PLAN
NOT FOR CONSTRUCTION



NEUROLOGICAL TRANSITIONAL CENTER

DUBLIN, OH

PROJECT NAME _____

SEAL _____

NO.	DESCRIPTION	DATE

STORM PROFILES

SHEET NAME _____

DATE October 19, 2022

PROJECT NUMBER 20220237

NO.	DESCRIPTION	DATE

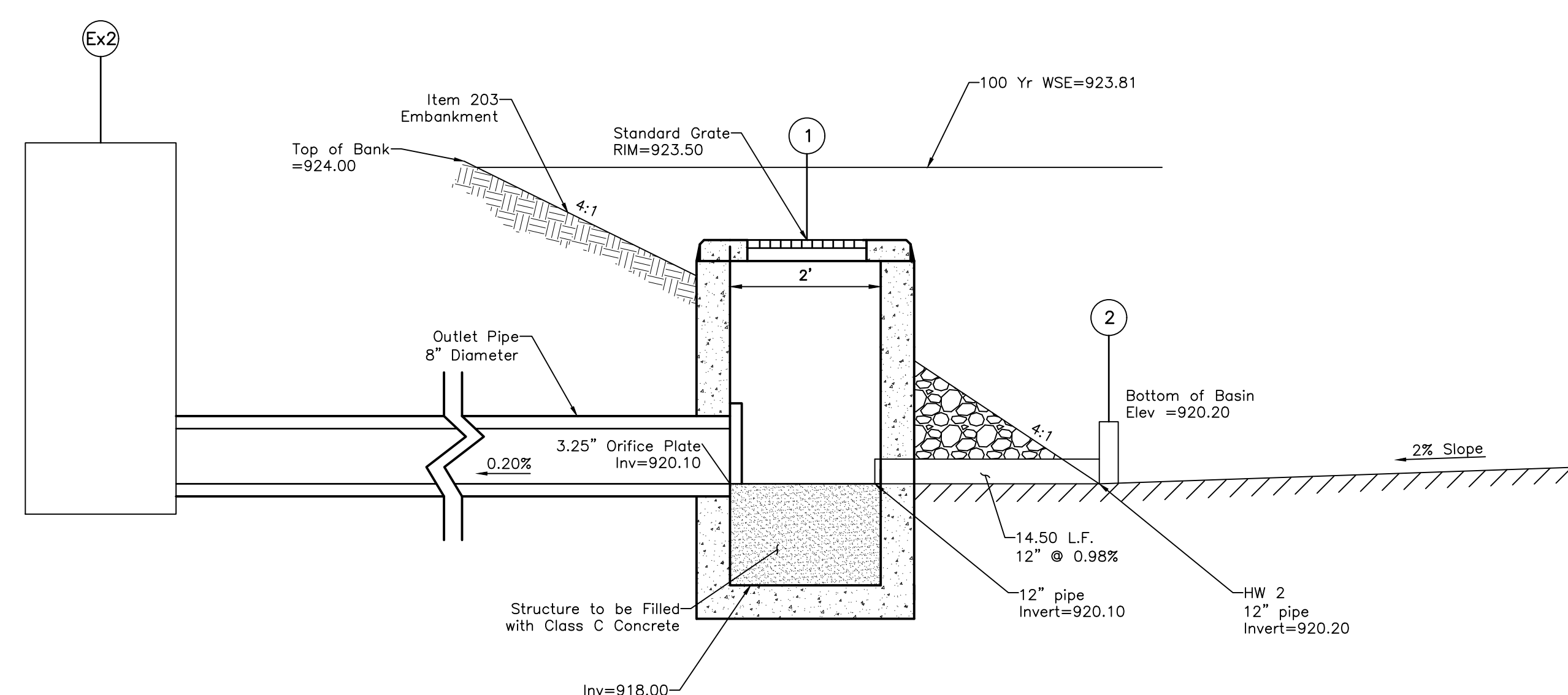

PROPOSED DRY BASIN #2 PERMANENT BASIN OUTLET STRUCTURE #1
Not to Scale

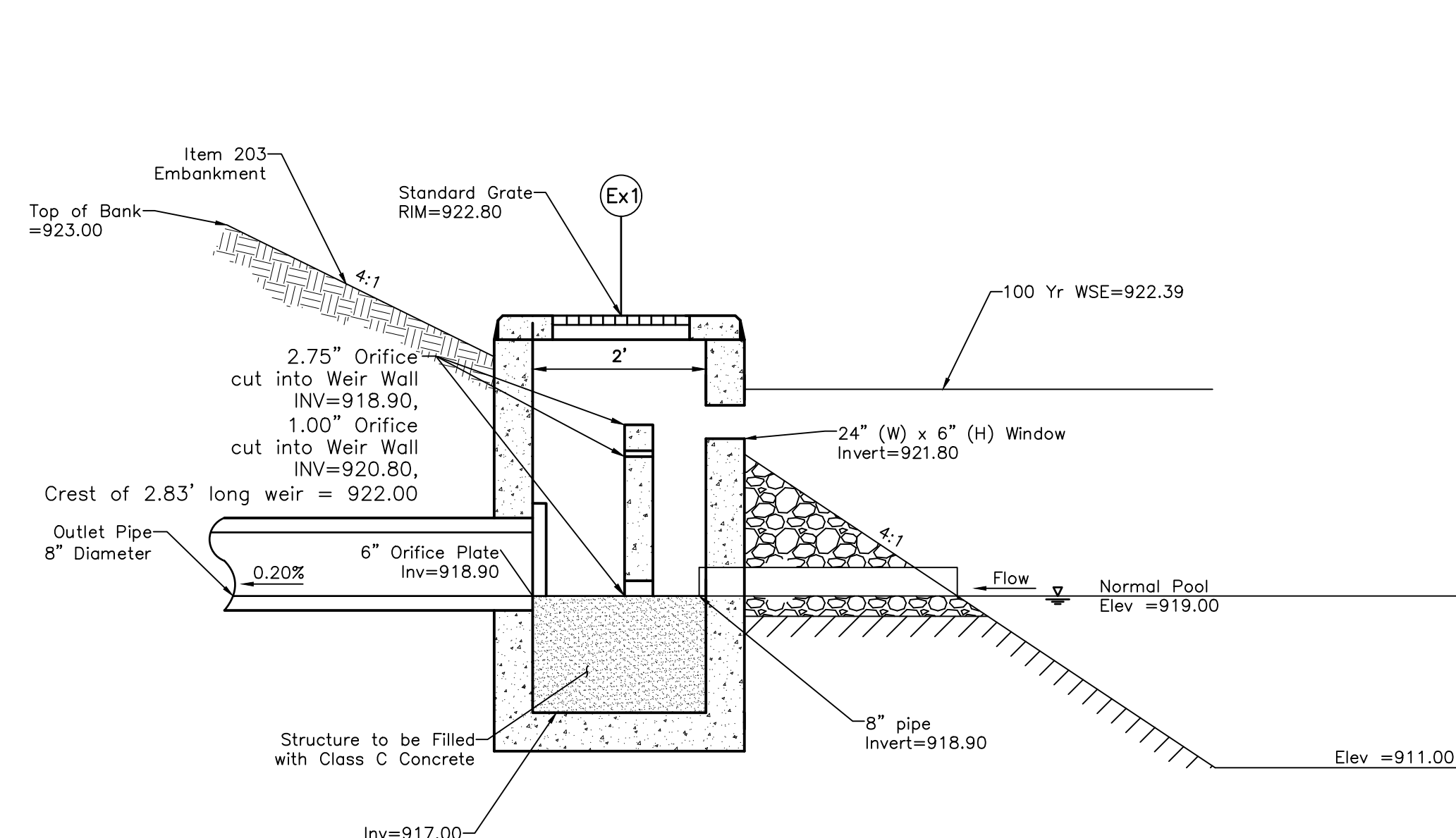

EXISTING WET BASIN #1 PERMANENT BASIN OUTLET STRUCTURE #1 MODIFIED
Not to Scale

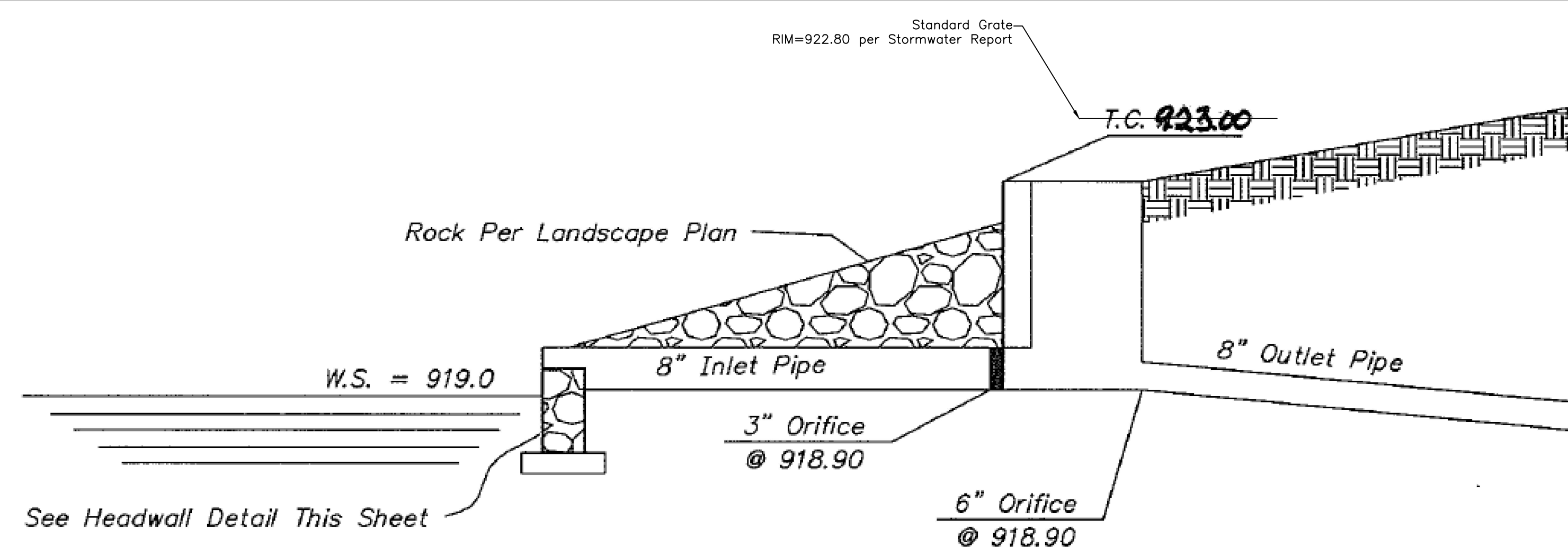

**CATCH BASIN #1 / BASIN
OUTLET STRUCTURE DETAIL**
NO SCALE

EXISTING WET BASIN #1 PERMANENT BASIN OUTLET STRUCTURE #1 PER PLANS/REPORT
Not to Scale

FINAL
DEVELOPMENT PLAN
NOT FOR
CONSTRUCTION



NEUROLOGICAL
TRANSITIONAL
CENTER

DUBLIN, OH

PROJECT NAME _____

SEAL _____

REVISIONS _____

NO.	DESCRIPTION	DATE

WATER SERVICE
PLAN TITLE SHEET

SHEET NAME _____

DATE October 19, 2022

PROJECT NUMBER 20220237

SHEET NUMBER **C1.2**

BENCH MARKS

The elevations shown on this map are based on the North American Vertical Datum of 1988. Said elevations are based upon positional solutions derived from RTK GPS observations using the Ohio Department of Transportation Virtual Reference System equipment and software and the National Geodetic Survey's GEOID12B model at traverse control points numbered 201, 202, 203, 204, 205, 206, 207, 208, 209, 210 and 211. Elevations from said traverse control points were then transferred by conventional leveling procedures to the permanent benchmarks listed hereon. (Fieldwork Completed 04/2019).

- BM#1 Chiseled square on the south side of a concrete light pole base located 90 feet southeast of the northeast corner of 6670 Perimeter Drive.
N:767807 Elev. = 926.77 (NAVD 88)
E:1782181
- BM#2 Chiseled square on the south side of a concrete light pole base located 180 feet southeast of the northeast corner of 6670 Perimeter Drive.
N:767801 Elev. = 926.27 (NAVD 88)
E:1782283
- BM#3 Chiseled triangle on the east side of a sanitary manhole rim located 60 feet north of Perimeter Drive and 270 feet east of the entrance drive of 6670 Perimeter Drive.
N:767505 Elev. = 924.76 (NAVD 88)
E:1782361
- BM#4 Chiseled triangle on the east side of a sanitary manhole rim located 50 feet north of Perimeter Drive and 30 feet east of the entrance drive of 6670 Perimeter Drive.
N:767444 Elev. = 925.25 (NAVD 88)
E:1782131

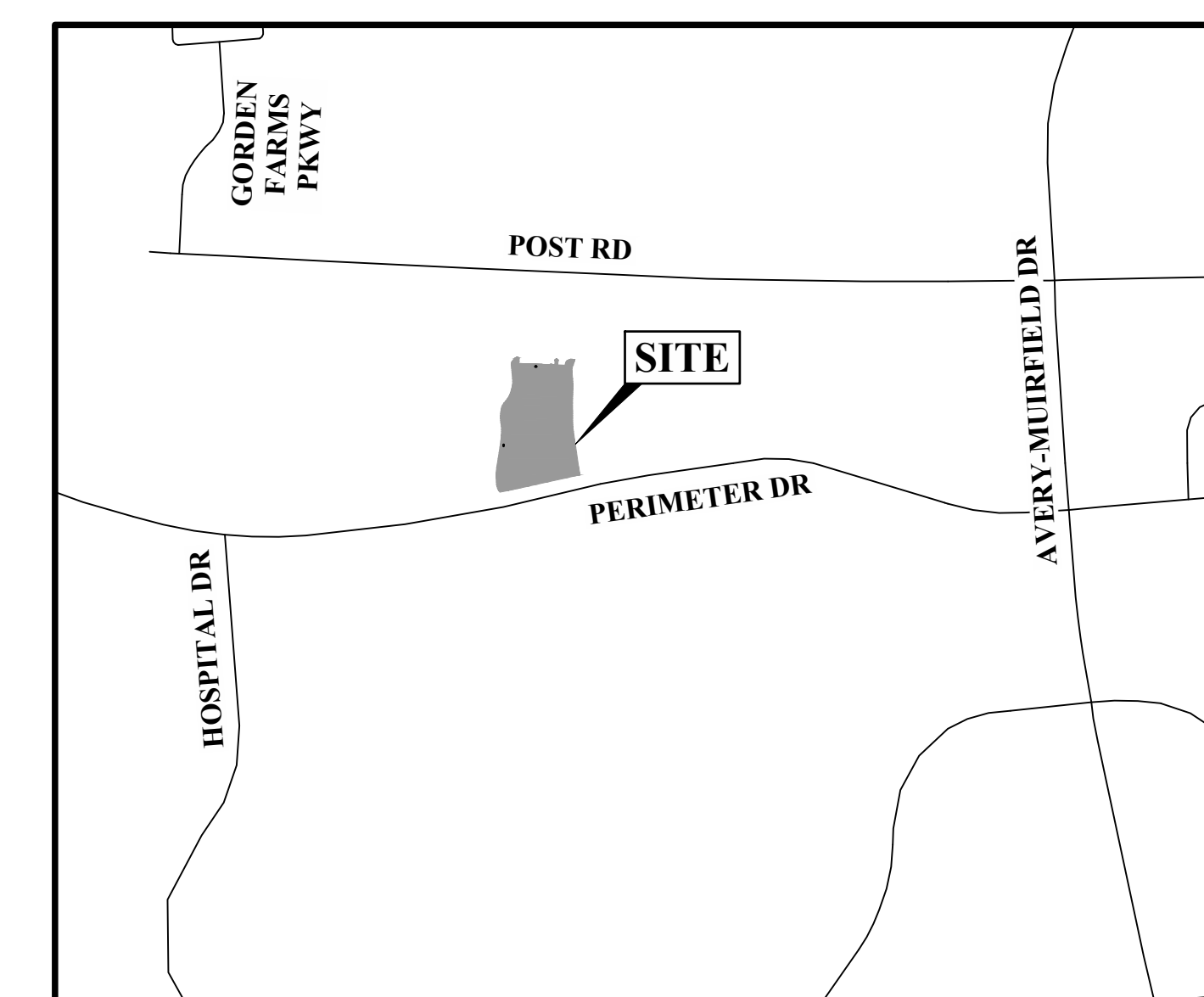

LOCATION MAP
Not to Scale

SHEET INDEX

TITLE	SHEET
TITLE SHEET	1
PLAN & PROFILE	2

DEVELOPER/OWNER

Select Medical
Nick Belfer
4714 Gettysburg Road
Mechanicsburg, PA 17055
Tel: (717) 215-4411
Email: NBelfer@selectmedical.com

ENGINEER

EMH&T INC.
Joe Walker, PE
5500 New Albany Rd
Columbus, Ohio 43054
Tel: (614) 775-4629
Email: jwalker@emht.com

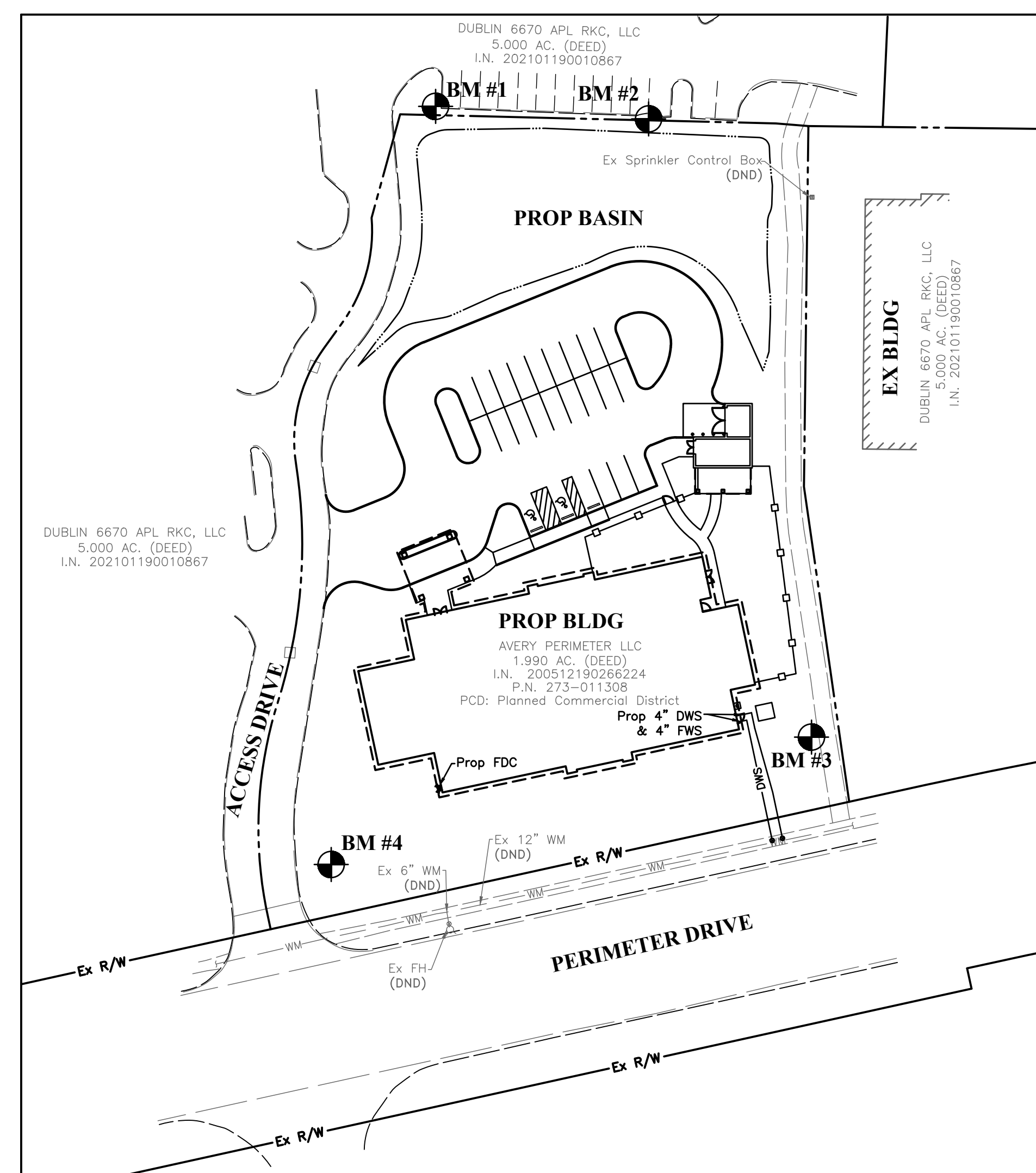

INDEX MAP
Scale: 1" = 50'

GRAPHIC SCALE

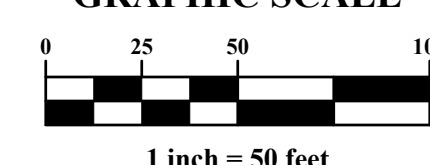

STANDARD CONSTRUCTION DRAWINGS

The Standard Drawings listed on these plans shall be considered a part thereof:

City of Columbus		
L-6306	L-6312	L-6640
L-6309	L-6316	L-9002C
L-6310	L-6317A&B	L-9002G
L-6311	L-6637	

EASEMENT REFERENCE

REVISIONS



REGISTERED ENGINEER NO. DATE

APPROVED FOR GENERAL ARRANGEMENTS

ONLY.
DIVISION OF WATER
CITY OF COLUMBUS

NEUROLOGICAL
TRANSITIONAL CENTER
DUBLIN OH
TITLE SHEET
PID: 273-011308

WSP-XXXX

1 / 2

NO.	DESCRIPTION	DATE

CITY OF COLUMBUS WATER SERVICE PLAN NOTES

NO WATER SERVICE CONSTRUCTION, BEFORE OR AFTER THE WATER METER(S), SHALL BEGIN PRIOR TO FEE PAYMENT TO THE UTILITY PERMITS OFFICE AT 111 N. FRONT STREET (614-645-7330).

THE CITY OF COLUMBUS, CONSTRUCTION AND MATERIAL SPECIFICATIONS (CMSC), 2018 EDITION AND ALL REVISIONS, INCLUDING SPECIAL PROVISIONS AND SUPPLEMENTAL SPECIFICATIONS SHALL GOVERN THIS IMPROVEMENT, UNLESS OTHERWISE NOTED.

ALL WATER LINE MATERIALS AND INSTALLATIONS SHALL BE IN ACCORDANCE WITH THE CURRENT APPROVED MATERIALS LIST AND RULES AND REGULATIONS OF THE CITY OF COLUMBUS, DIVISION OF WATER, UNLESS OTHERWISE SHOWN ON THE PLANS OR APPROVED BY THE CITY OF COLUMBUS DIVISION OF WATER. ONLY PRODUCTS LISTED ON THE CURRENT APPROVED MATERIALS LIST WILL BE PERMITTED TO BE INSTALLED.

IT SHALL BE UNLAWFUL FOR ANY PERSON TO PERFORM ANY WORK ON THE PUBLIC WATER DISTRIBUTION SYSTEM WITHOUT FIRST SECURING A LICENSE TO ENGAGE IN SUCH WORK, AS INDICATED IN COLUMBUS CITY CODE SECTIONS 1103.02 AND 1103.05. THIS WORK INCLUDES ANY ATTACHMENTS, ADDITIONS TO OR ALTERATIONS IN ANY CITY SERVICE PIPE OR APPURTENANCES (INCLUDING WATER SERVICE LINES AND WATER SERVICE TAPS). THIS REQUIREMENT MAY BE MET BY UTILIZATION OF A SUBCONTRACTOR WHO POSSESSES A CITY OF COLUMBUS WATER CONTRACTOR LICENSE OR A COMBINED WATER/SEWER CONTRACTOR LICENSE TO PERFORM THIS WORK. UTILIZATION OF A SUBCONTRACTOR MUST MEET THE LICENSING REQUIREMENTS OF CITY OF COLUMBUS BUILDING CODE, IN PARTICULAR SECTIONS 4114.119 AND 4114.529.

FOR ANY EMERGENCIES THAT OCCUR AFTER NORMAL WORKING HOURS INVOLVING THE WATER DISTRIBUTION SYSTEM, PLEASE CONTACT THE DIVISION OF WATER DISTRIBUTION MAINTENANCE OFFICE AT 614-645-7788.

SITE UTILITY CONTRACTOR SHALL OBTAIN A RIGHT OF WAY PERMIT PRIOR TO THE START OF ANY WATER SERVICE LINE AND/OR WATER SERVICE TAP INSTALLATION OR ANY PLACEMENT OF WATER SERVICE MATERIALS INTO THE PUBLIC RIGHT OF WAY.

THERE SHALL BE A 10 FOOT MINIMUM HORIZONTAL AND 18 INCH VERTICAL SEPARATION BETWEEN WATER SERVICE TAP(S), WATER SERVICE LINE(S), PRIVATE WATER SYSTEMS AND ANY SANITARY AND/OR STORM SEWER SYSTEMS.

EXISTING RIGHT OF WAY LINE(S), PROPOSED RIGHT OF WAY LINE(S) AND/OR WATER MAIN EASEMENT LINES SHALL BE STAKED AT 10 FOOT INCREMENTS BY A STATE OF OHIO LICENSED SURVEYOR WHEN THE WATER SERVICE TAP(S) AND/OR WATER SERVICE(S) ARE INSTALLED AND INSPECTED BY THE COLUMBUS DIVISION OF WATER.

ALL INSPECTIONS REQUIRE A 24 HOUR ADVANCE NOTICE.

SITE UTILITY CONTRACTOR SHALL FLUSH ALL WATER SERVICES PRIOR TO ANY WATER METER INSTALLATION. THE CITY OF COLUMBUS IS NOT RESPONSIBLE FOR ANY CITY WATER METER DAMAGE CAUSED BY NON-FLUSHING.

SITE UTILITY CONTRACTOR SHALL CALL COLUMBUS DIVISION OF WATER AT 614-645-7330 FOR INSPECTION OF 2" AND SMALLER WATER SERVICE TAPS FROM THE WATER MAIN THRU THE CURB STOP AND WATER SERVICES FROM THE CURB STOP THRU THE WATER METER SETTING.

SITE UTILITY CONTRACTOR SHALL CALL COLUMBUS DIVISION OF WATER AT 614-645-7330 FOR INSPECTION AND HYDROSTATIC TEST OF 3" AND LARGER WATER SERVICE TAPS FROM THE WATER MAIN THRU THE CONTROL VALVE AND WATER SERVICES FROM THE CONTROL VALVE THRU THE WATER METER SETTING. HYDROSTATIC TEST SHALL BE PER CMSC ITEM 801.14 AND SHALL BE PERFORMED FROM THE WATER MAIN THRU THE WATER METER SETTING.

ALL 3" THRU 12" WATER SERVICE PIPE SHALL BE ONLY DUCTILE IRON FROM THE CITY WATER MAIN THRU THE CITY WATER METER SETTING(S) INCLUDING THE METER BYPASS.

ALL EXPOSED WATER MAIN AND ALL WATER SERVICE PIPE 3" AND LARGER SHALL BE POLYWRAPPED PER CMSC ITEM 801.03 TO A POINT 10 FEET BEYOND THE RIGHT OF WAY VALVE(S).

3" AND LARGER METER SETTING(S) SHALL BE PER COLUMBUS DIVISION OF WATER STANDARD DETAIL DRAWINGS L-6317 A-E.

2" AND LARGER METERS SHALL BE PURCHASED AT THE UTILITY PERMITS OFFICE AT 111 N. FRONT STREET AND PICKED UP AT UTILITY METERING SERVICES AT 3568 INDIANOLA AVENUE.

BACKFLOW PREVENTION ASSEMBLY(S) SHALL BE INSTALLED, WHERE REQUIRED, PER COLUMBUS DIVISION OF WATER STANDARD DETAIL DRAWINGS L-9002 A THRU G. CONTRACTOR(S) SHALL CALL 614-645-6674 WITH BACKFLOW PREVENTION QUESTIONS. CONTRACTOR(S) SHALL CALL 614-645-5781 TO SCHEDULE BACKFLOW PREVENTION INSPECTION REQUESTS.

DOMESTIC WATER SERVICE BACKFLOW PREVENTER(S) SHALL MEET THE ASSE #1013 APPROVAL/STANDARD AND SHALL BE SIZED TO MATCH THE CITY WATER METER.

THE FIRE WATER SERVICE BACKFLOW PREVENTER(S) SHALL MEET THE APPROPRIATE ASSE APPROVAL/STANDARD AND SHALL BE EQUIPPED WITH A DETECTOR METER THAT IS (IRON 100R (TOWER) OR 100R (REMOTE) COMPATIBLE, MEASURES IN CUBIC FEET AND MEETS THE AWWA C-700 STANDARD. FIRE WATER BACKFLOW PREVENTER(S) SHALL BE SIZED TO MATCH THE FIRE WATER SERVICE SIZE AND EQUIPPED WITH O.S.&Y. VALVES.

IF DOMESTIC AND/OR FIRE WATER SERVICE METER(S) AND THEIR BACKFLOW PREVENTER(S) ARE TO BE LOCATED IN A METER ROOM INSIDE A BUILDING, THERE WILL BE A WALL OR CEILING MOUNTED GAS OR ELECTRIC THERMOSTATICALLY OPERATED HEATER. THE HEATER SHALL BE SIZED PER THE HEATER MANUFACTURER SPECS TO MAINTAIN A 40 DEGREE FAHRENHEIT INSIDE TEMPERATURE AT AN OUTSIDE TEMPERATURE OF MINUS 30 DEGREE FAHRENHEIT.

BACKFLOW PREVENTION DEVICES MUST BE TESTED AT THE TIME OF INSTALLATION BY A TESTER APPROVED BY THE DIVISION OF WATER BACKFLOW COMPLIANCE OFFICE. A COMPLETE LIST OF APPROVED TESTERS CAN BE FOUND AT WWW.COLUMBUS.GOV/BACKFLOW/CONSUMERS. RESULTS MUST BE SUBMITTED THROUGH THE ONLINE WEB SUBMITAL SYSTEM AT WWW.COLUMBUS.TOWNTTEST.COM.

UNDERGROUND PRIVATE WATER SYSTEMS BEYOND METERS

SITE UTILITY CONTRACTOR SHALL CALL CITY OF NEW ALBANY FOR INSPECTION OF UNDERGROUND PRIVATE DOMESTIC AND/OR FIRE WATER SYSTEM(S) AFTER THE CITY WATER METER(S). THIS WILL INCLUDE DOMESTIC WATER LOOPS AND FIRE WATER LOOPS INCLUDING PRIVATE FIRE HYDRANTS THRU THE SITE BEFORE COVERING.

SITE UTILITY CONTRACTOR SHALL CALL CITY OF NEW ALBANY FOR FLUSHING AND/OR PRESSURE TEST INSPECTION OF PRIVATE FIRE SYSTEM AFTER THE CITY FIRE WATER SERVICE METER AND BACKFLOW PREVENTER.

4" AND LARGER PIPE MATERIAL FOR THE UNDERGROUND PRIVATE WATER SYSTEM AFTER THE CITY WATER METER SHALL BE DUCTILE IRON, C-900 OR C-909 PIPE ONLY TO A POINT 5' OUTSIDE THE BUILDING FOOTPRINT.

FIRE PROTECTION SYSTEM USES WATER ONLY. THE SITE DOES NOT HAVE ACCESS TO AN AUXILIARY WATER SYSTEM AND THE SYSTEM IS NOT SUBJECT TO CHEMICAL ADDITIVES.

NOTES:

All Valves include Standard Valve Boxes unless otherwise noted.

Water stationing based on E Fire Water Service (FWS).

DWS Domestic Water Service Before Meter

FWS Fire Water Service Before Meter

All Backfill within Right-Of-Way shall be CDF.

Water Service and Water line to be lowered a minimum of 1.5' below storm sewer/underdrain in case of conflict. See COC Std Detail L-7401.

Contractor to verify elevation and location of existing utility before construction.

LEGEND

— STM —	Storm Sewer	— SAN —	Sanitary Sewer	— WM —	Water Main	— UGL —	Lighting Conduit	— E —	Electric Duct Bank	— OHE —	Overhead Electric Lines	— FO —	Fiber Optic Duct Bank
○	Fire Hydrant	○	Manhole	□	Catch Basin	□	Electric Duct Bank Manhole	□	Communication Manhole	○	Relocated Fire Hydrant (FH)	○	Water Valve
○	Water Valve	○	Light Pole	□	Manhole	□	Manhole	□	Manhole	○	Fire Department connection (FDC)	○	Site Light Pole (See MEP Plan)

PROPOSED

— STM —	Storm Sewer	— RD —	Roof Drain	— SAN —	Sanitary Sewer	— SAS —	Sanitary Service (SAS)	— FWS —	Public Fire Water Service	— DWS —	Private Domestic Water Service
---------	-------------	--------	------------	---------	----------------	---------	------------------------	---------	---------------------------	---------	--------------------------------

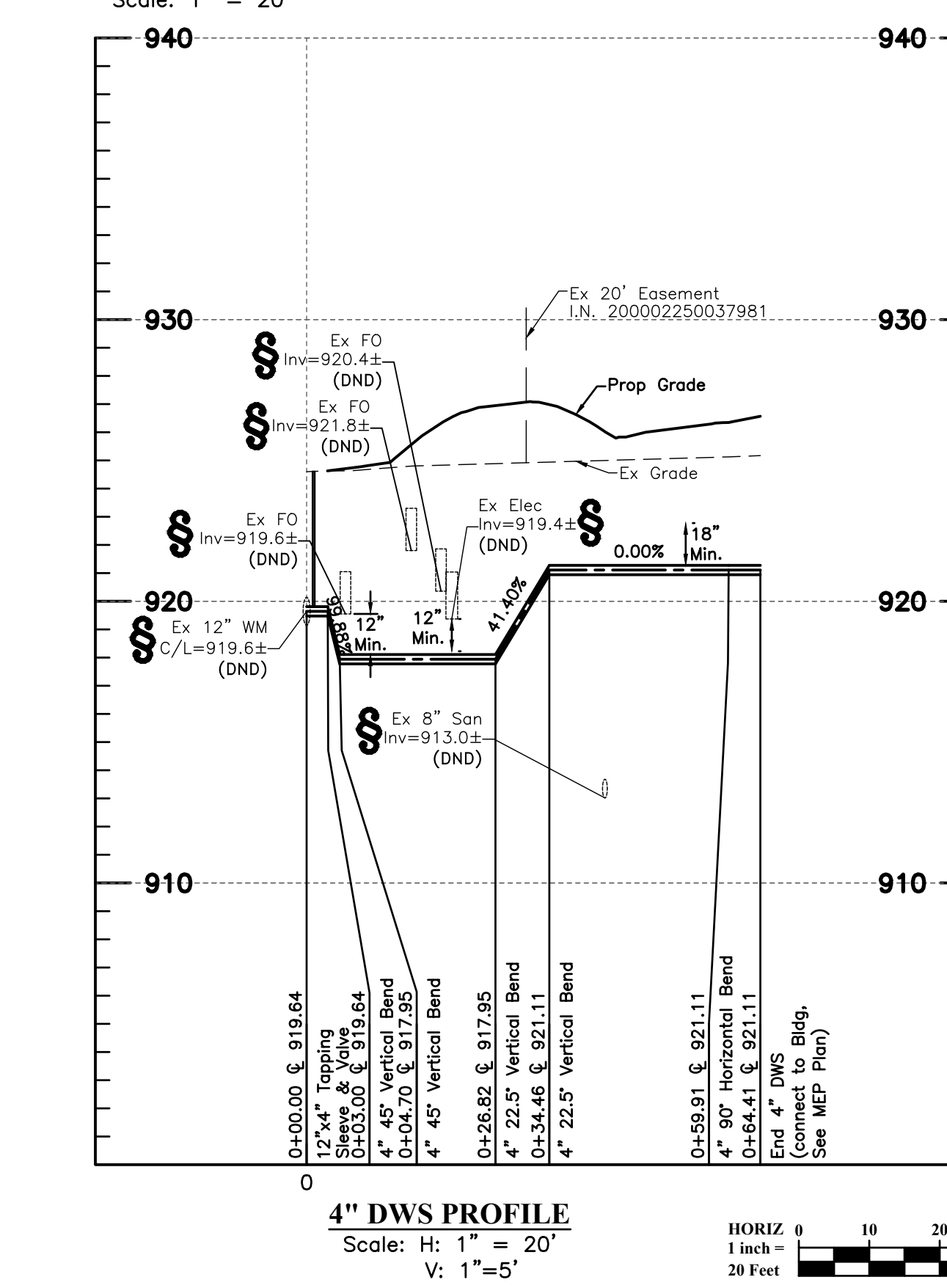
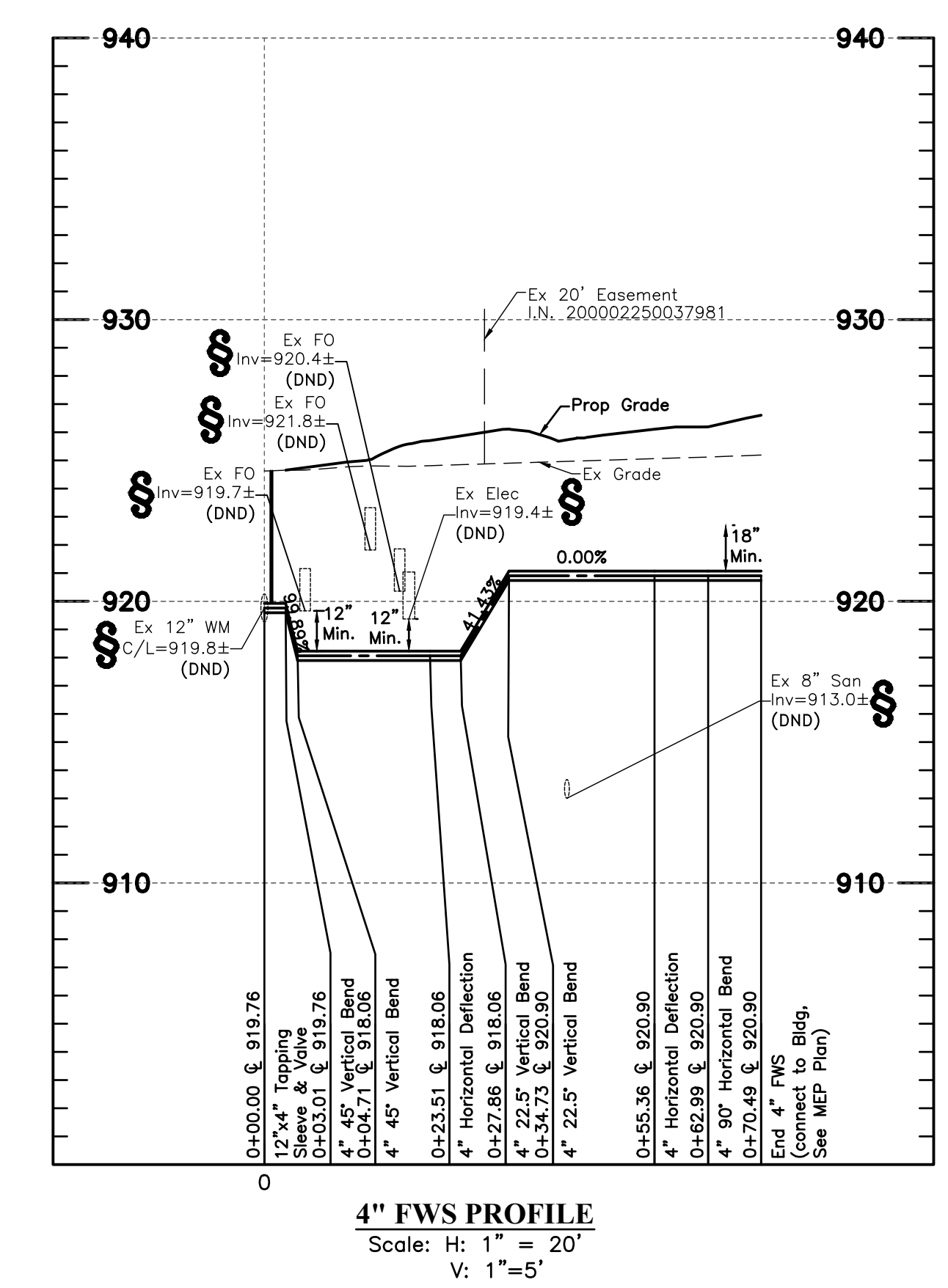
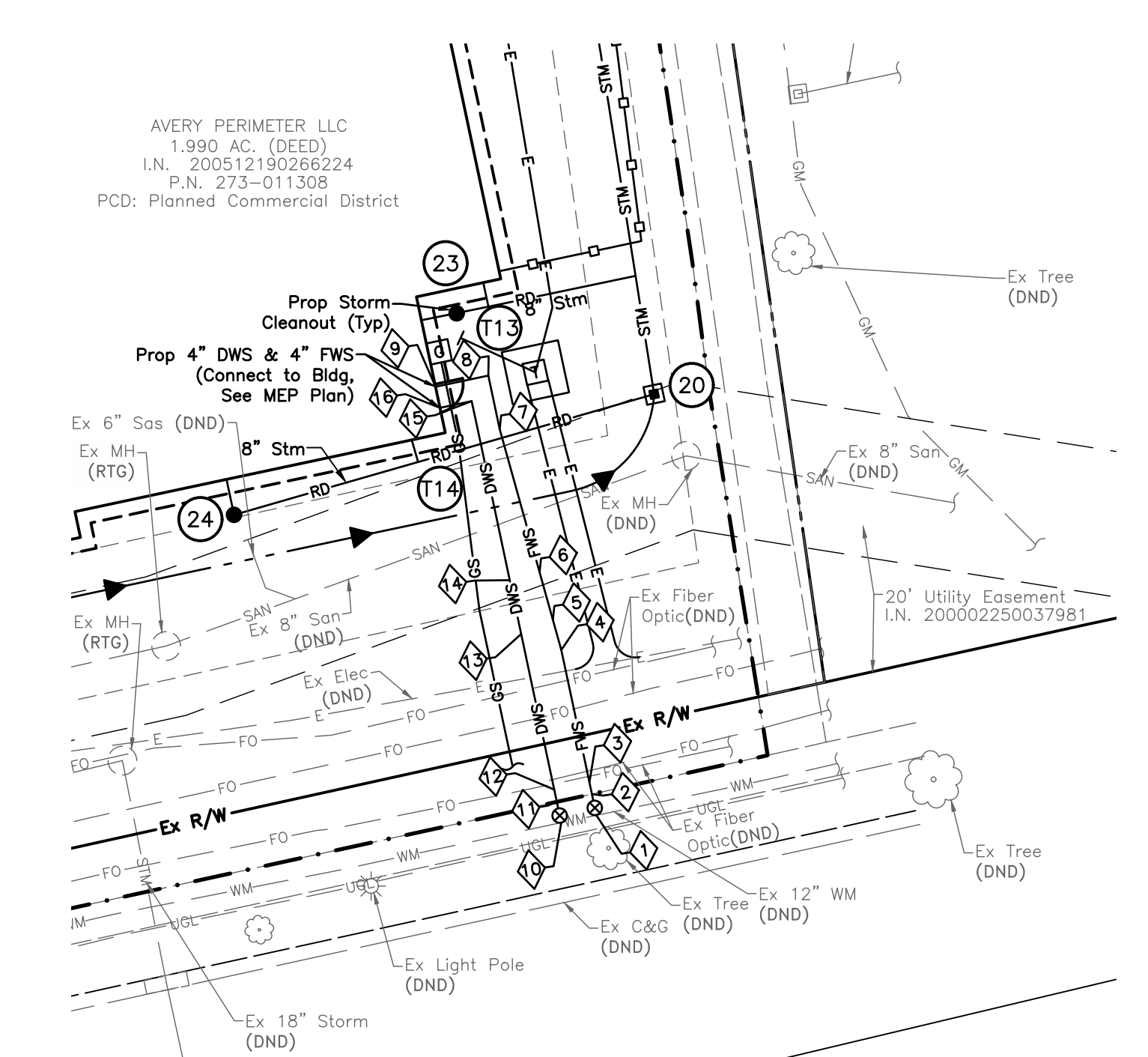

SURVEY COORDINATE TABLE FOR 4" FWS & DWS

REF	ITEM	NORTHING	EASTING
1	12"x4" Tapping Sleeve & Valve	767455.5186	1782347.3079
2	4" 45° Vertical Bend	767458.4645	1782346.6818
3	4" 45° Vertical Bend	767460.1274	1782346.3283
4	4" Horizontal Deflection	767478.5147	1782342.4200
5	4" 22.5° Vertical Bend	767482.7063	1782341.2497
6	4" 22.5° Vertical Bend	767489.3178	1782339.4037
7	4" Horizontal Deflection	767509.1957	1782333.8538
8	4" 90° Horizontal Bend	767516.6565	1782332.2680
9	End 4" FWS	767515.0972	1782324.9319
10	12"x4" Tapping Sleeve & Valve	767454.4968	1782342.4134
11	4" 45° Vertical Bend	767457.4347	1782341.7889
12	4" 45° Vertical Bend	767459.0976	1782341.4355
13	4" 22.5° Vertical Bend	767480.7273	1782336.8379
14	4" 22.5° Vertical Bend	767488.2004	1782335.2495
15	Null Structure	767513.0983	1782329.9573
16	End 4" DWS	767512.1627	1782325.5556

ESTIMATE OF QUANTITIES

Item	Quantity	Unit	Description
B01	135	L.F.	4" Water Pipe and Fittings
B03	2	Each	12"x4" Tapping Sleeve & Valve
Spec	Lump	Sum	Survey Coordinates

EASEMENT REFERENCE

REVISIONS



**NEUROLOGICAL
TRANSITIONAL CENTER
DUBLIN OH
PLAN & PROFILE
PID: 273-011308**

WSP-XXXX

J:\20220237\DWG\945Sheets\Plan_Sets\20220237_Landscape_Plan.dwg, Last Saved By: pschoeffer, 10/19/2022 9:59 AM, Last Printed By: pschoeffer, 10/19/2022 3:22 PM (No Xrefs)

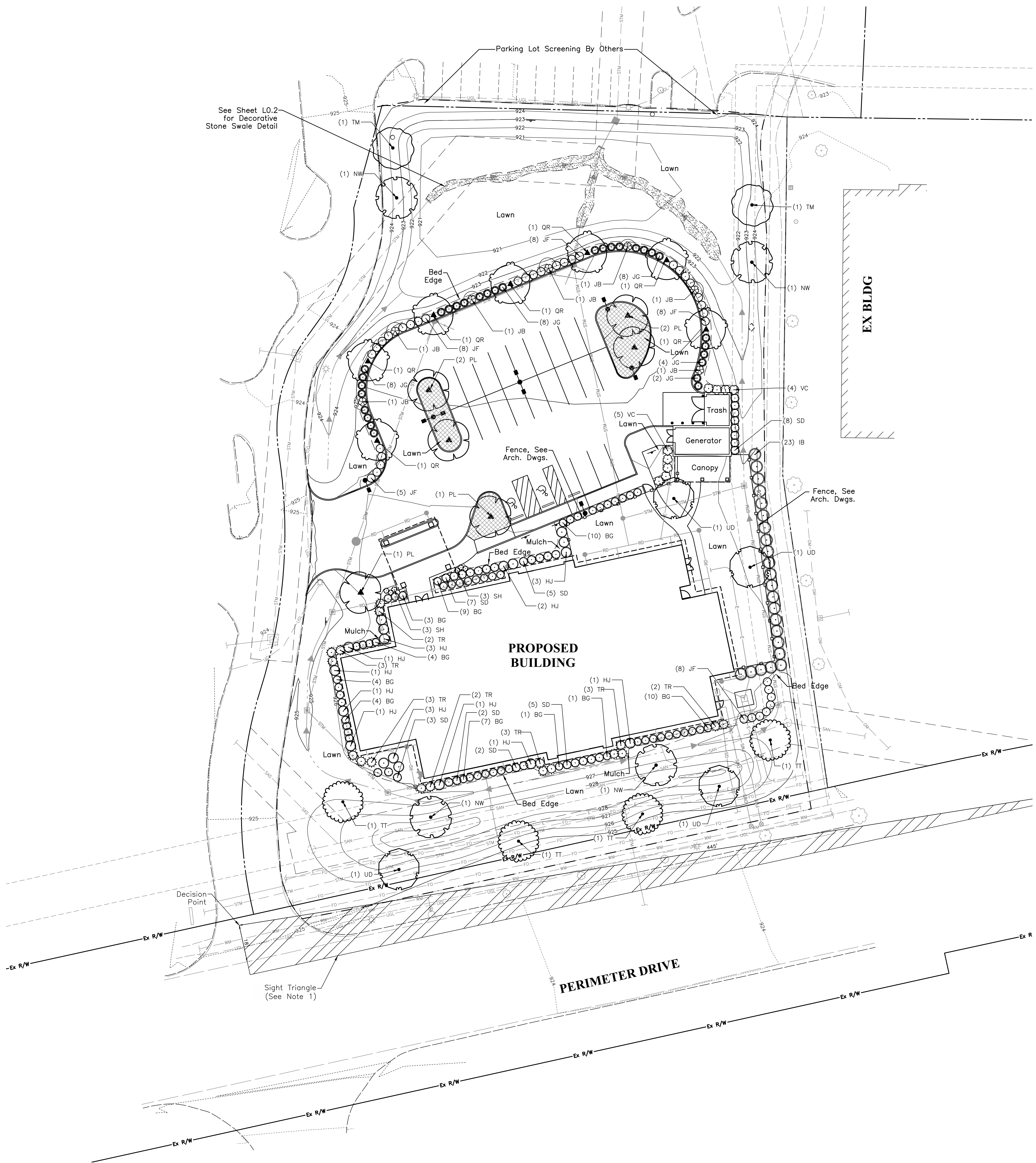

Landscape Calculations

- 153.133 - Minimum Landscape Requirements:
- ▲ (A) Perimeter buffer landscape requirements
 - (5) Vehicular use area perimeter requirements. Appendix B. Evergreen hedge provided.
 - ±280 LF / 40 = 7 Perimeter Trees Required
 - 7 Perimeter Trees Provided
 - ▲ (B) Interior Landscaping for Vehicular Use Areas:
 - One Tree per peninsula or island counted towards required landscape area.
 - 3 islands provided = 3 Trees Required
 - 3 Trees Provided
 - (2): Landscape Area: For each 100 SF a minimum of 5 SF of landscaped area required.
 - ±15,900 SF VUA (5%) = ±795 SF Landscape Area Required
 - ±1,320 SF Landscape Provided
 - (3): Tree planting Requirement: Following number and size of trees are required within interior landscaped area. One tree for every 5,000 SF of total ground coverage of structures and VUA.
 - 1 Tree / 5,000 SF Ground Coverage
 - ±30,000 SF / 5000 SF = 6 Trees Required, 2" Caliper
 - 6 Trees Provided, 2" Caliper
 - (D): Additional Site Planting Requirements
 - (2) Site Planting Requirements: 1" in tree size for every 1,500 SF of building ground coverage
 - ±14,150 SF Building Ground Coverage
 - ±14,150 / 1,500 = ±9.43 Caliper Required (5 trees at 2" caliper)
 - 28" Caliper Provided (14 Site Trees at 2" caliper)
 - 54" Total Caliper Provided (14 Site Trees + 13 Parking Lot Trees)

PLANT SCHEDULE

SITE TREES	CODE	QTY	BOTANICAL / COMMON NAME	SIZE	CONDITION
	NW	4	Nyssa sylvatica 'Wildfire' Wildfire Black Gum	2" Cal.	B&B
	TM	2	Taxodium distichum 'Mickelson' Shawnee Brave Bald Cypress	6" Ht.	B&B
	TT	4	Tilia tomentosa 'Sterling' Sterling Silver Linden	2" Cal.	B&B
	UD	4	Ulmus parvifolia 'Dynasty' Dynasty Lacebark Elm	2" Cal.	B&B
PARKING LOT TREES	CODE	QTY	BOTANICAL / COMMON NAME	SIZE	CONDITION
	PL	6	Platanus x acerifolia 'Liberty' Liberty London Plane Tree	2" Cal.	B&B
	QR	7	Quercus rubra Red Oak	2" Cal.	B&B
SHRUBS	CODE	QTY	BOTANICAL / COMMON NAME	SIZE	CONDITION
	BG	53	Buxus x 'Glencoe' Chicagoled Green Boxwood	24" Ht.	Cont.
	HJ	18	Hydrangea paniculata 'Jane' Little Lime Panicle Hydrangea	24" Ht.	Cont.
	IB	23	Ilex x meserveae 'Blue Boy' Blue Boy Holly	36" Ht.	Cont.
	JG	30	Juniperus chinensis 'Gold Coast' Gold Coast Juniper	24" Ht.	Cont.
	JF	37	Juniperus chinensis 'Sea Green' Sea Green Juniper	24" Ht.	Cont.
	JB	7	Juniperus virginiana 'Burkii' Burk Eastern Redcedar	4" Ht.	Cont.
	SD	32	Spiraea x bumalda 'Denistar' Superstar Spiraea	24" Ht.	Cont.
	TR	18	Thuja occidentalis 'Rheingold' Rheingold Arborvitae	24" Ht.	Cont.
	VC	9	Viburnum carlesii 'Cayuga' Cayuga Koreonspice Viburnum	30" Ht.	Cont.
GRASSES	CODE	QTY	BOTANICAL / COMMON NAME	SIZE	CONDITION
	SH	6	Sporobolus heterolepis Prairie Dropseed	#2	Cont.

NOTE:
1. Sight Distance Triangle shown, per Policy No. 08-013, to illustrate compliance with the proposed site grading and landscape features.

PRELIMINARY
NOT TO BE USED FOR CONSTRUCTION

PLAN SET DATE
October 19, 2022

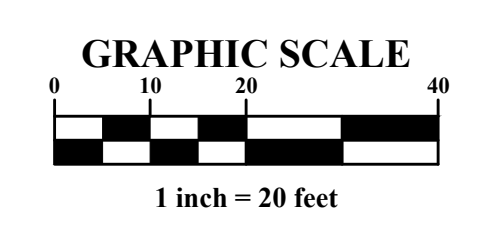

600 Main Street
Suite 300
North Little Rock, AR 72114
Phone: 501-758-7443

www.taggarch.com

FINAL DEVELOPMENT PLAN
NOT FOR CONSTRUCTION



NEUROLOGICAL TRANSITIONAL CENTER

DUBLIN, OH

PROJECT NAME _____

SEAL _____

REVISIONS

NO.	DESCRIPTION	DATE

LANDSCAPE PLAN

SHEET NAME _____

DATE October 19, 2022

PROJECT NUMBER 20220237

SHEET NUMBER **L0.1**

J:\20220237\DWG\945Sheets\Plan Set\20220237 Landscape Plan.dwg, Last Saved By: pschoeffer, 10/19/2022 9:19 AM, Last Printed By: pschoeffer, Phillip, 10/19/2022 9:35 AM (No Xrefs)

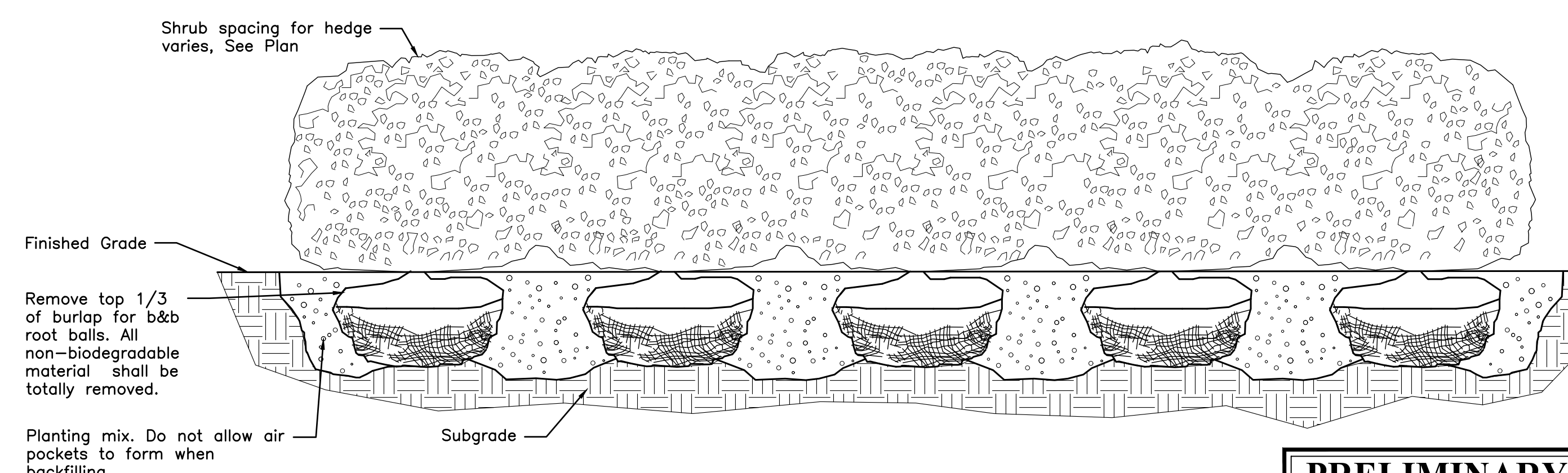
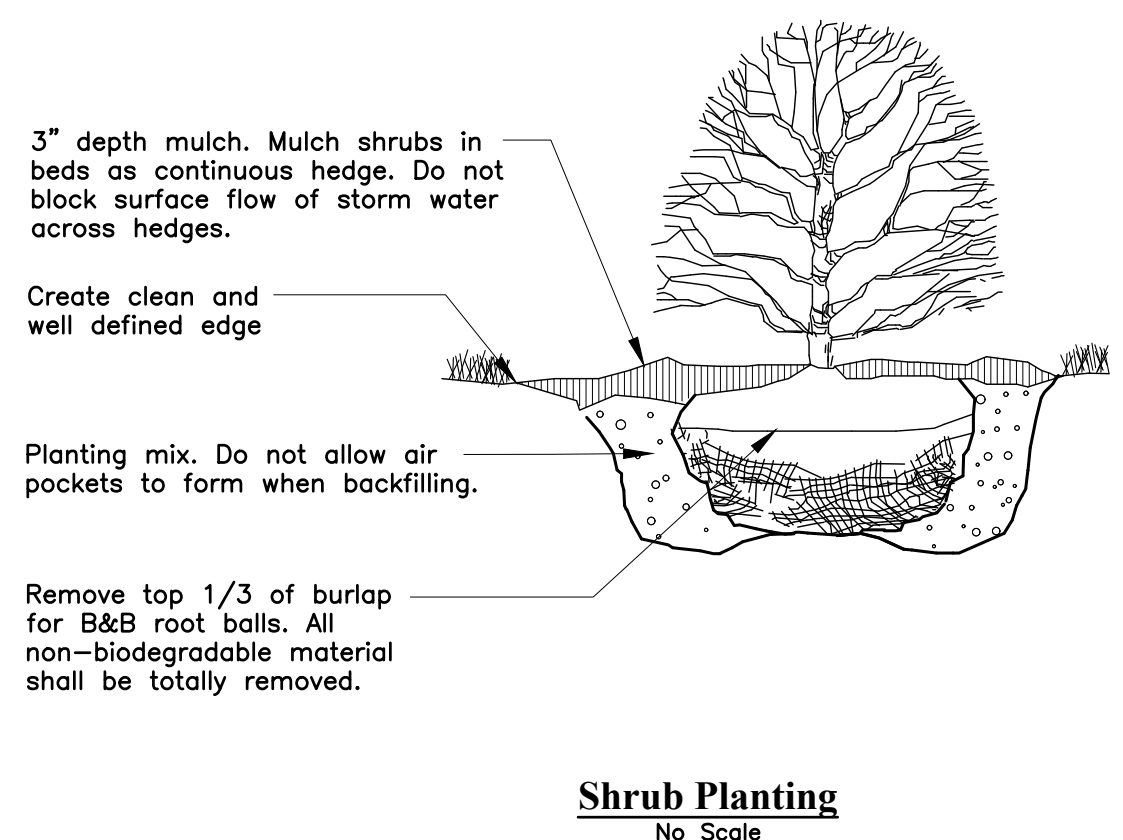
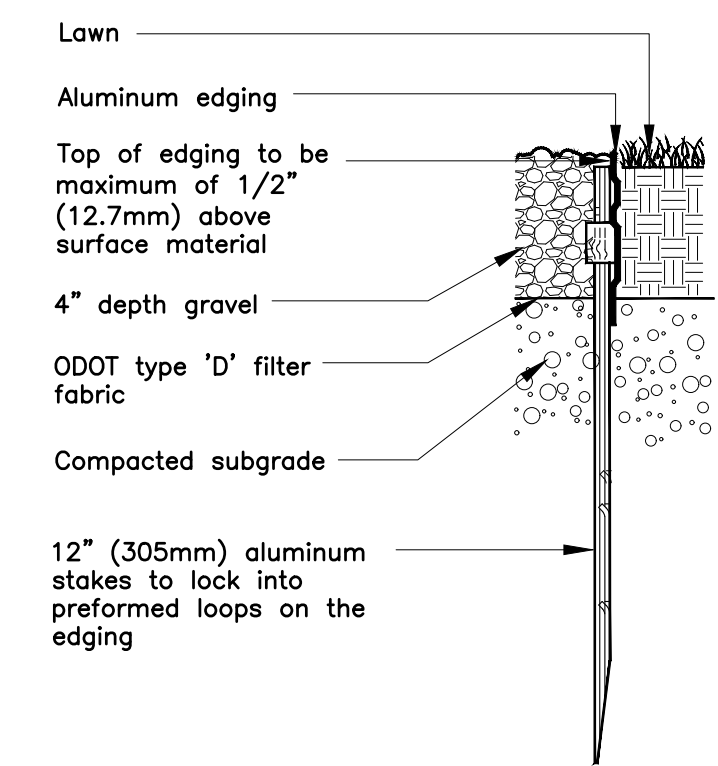
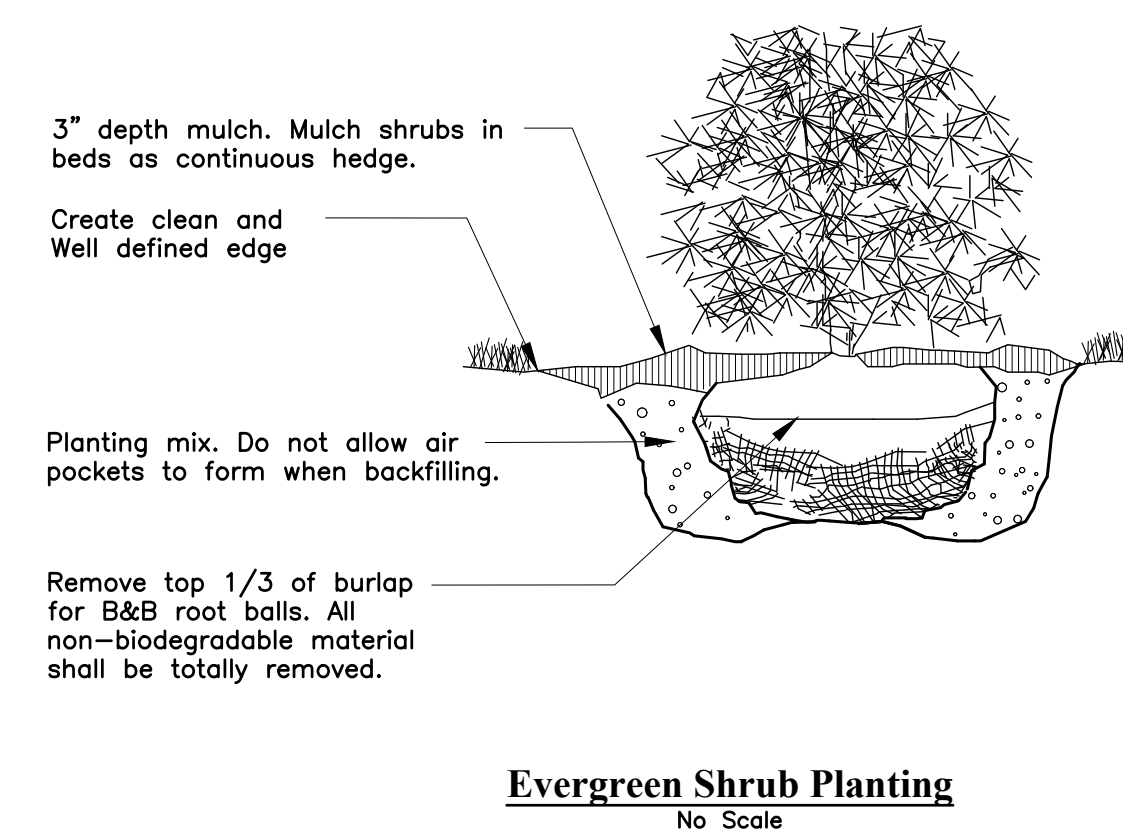
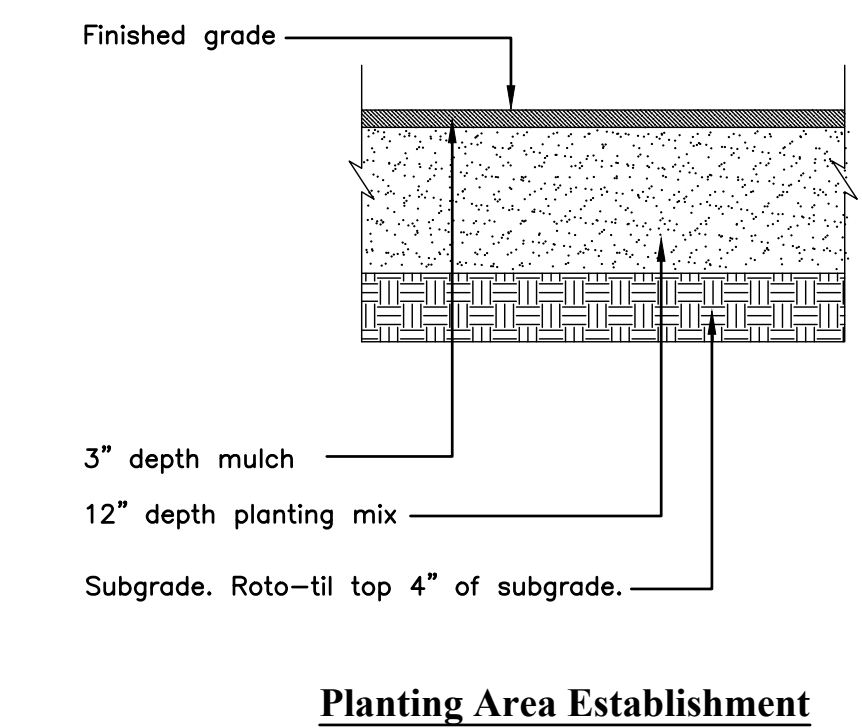
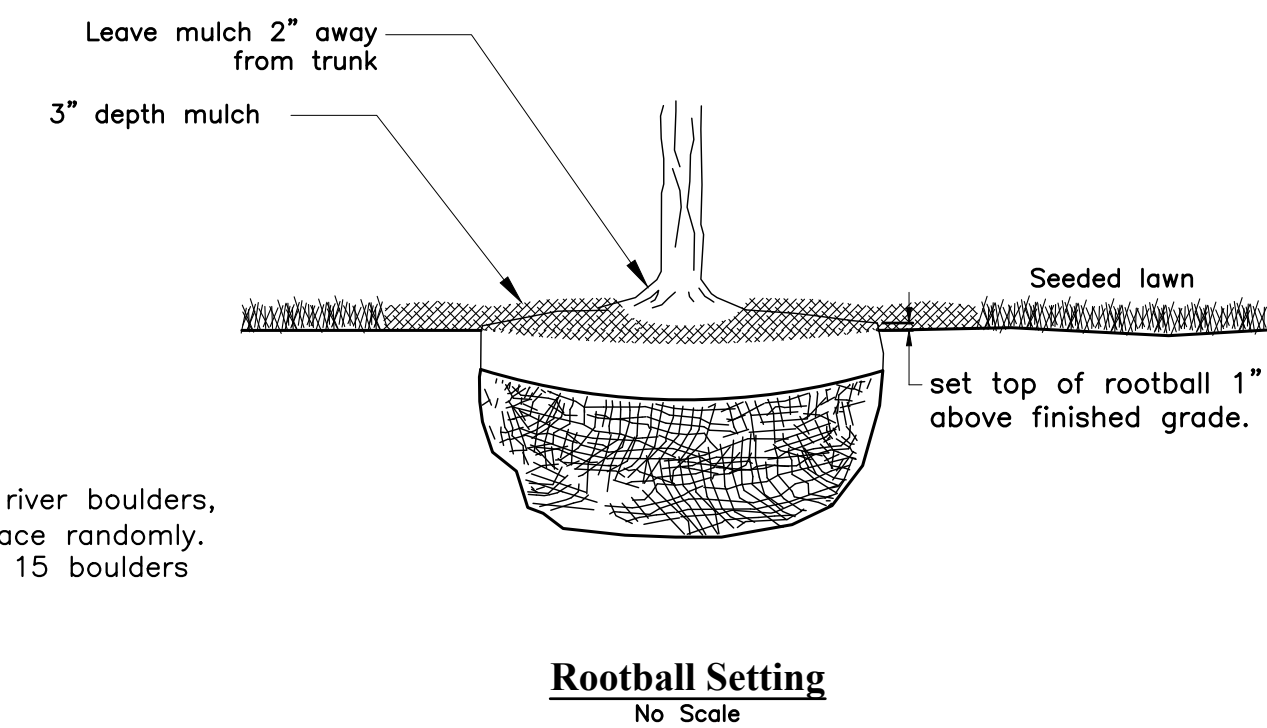
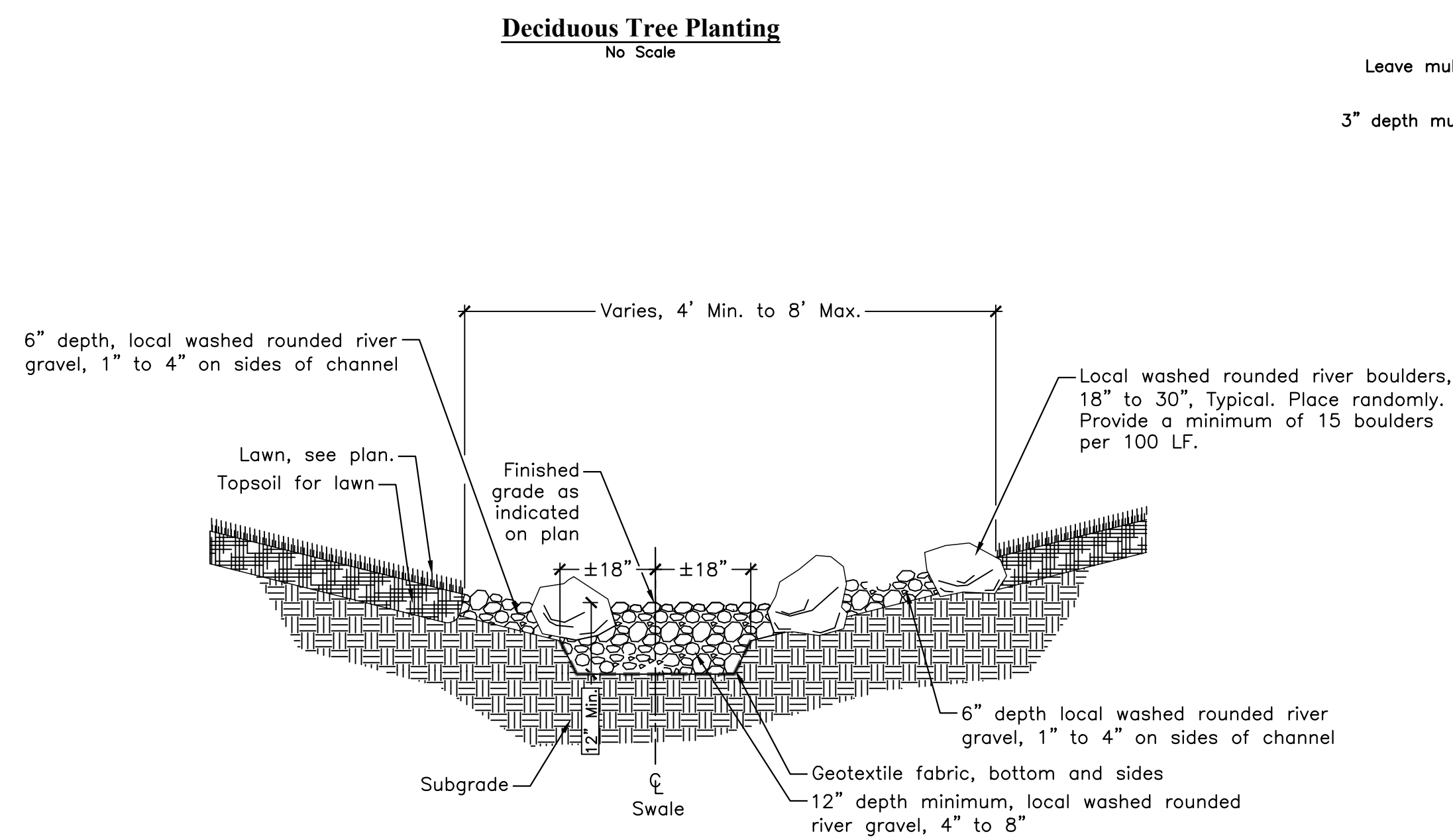
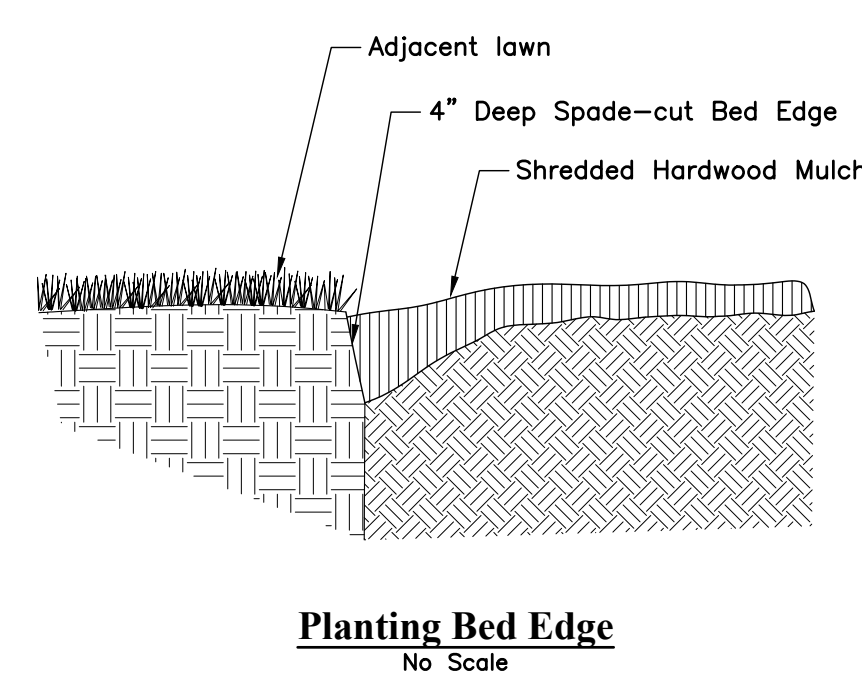
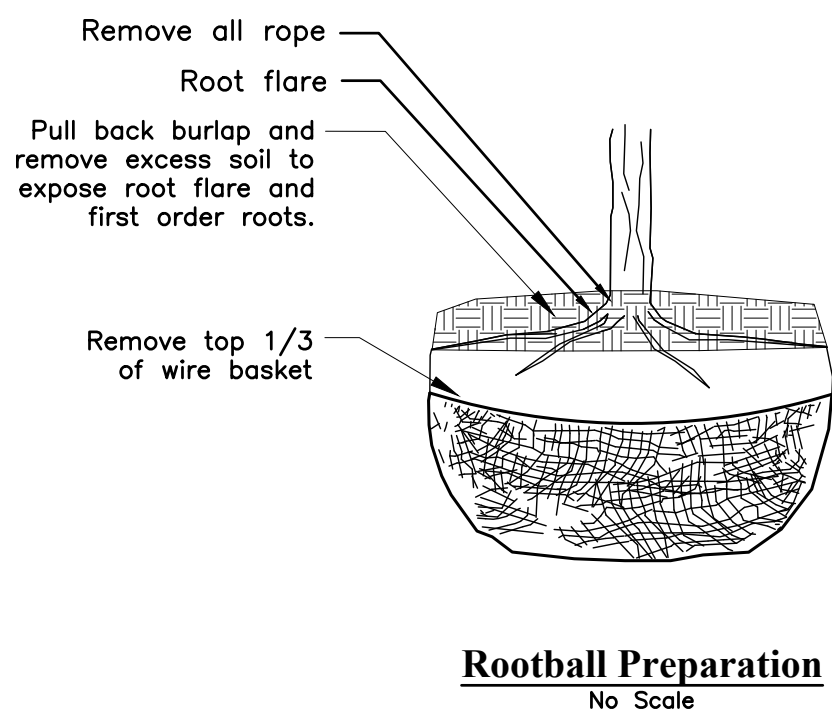
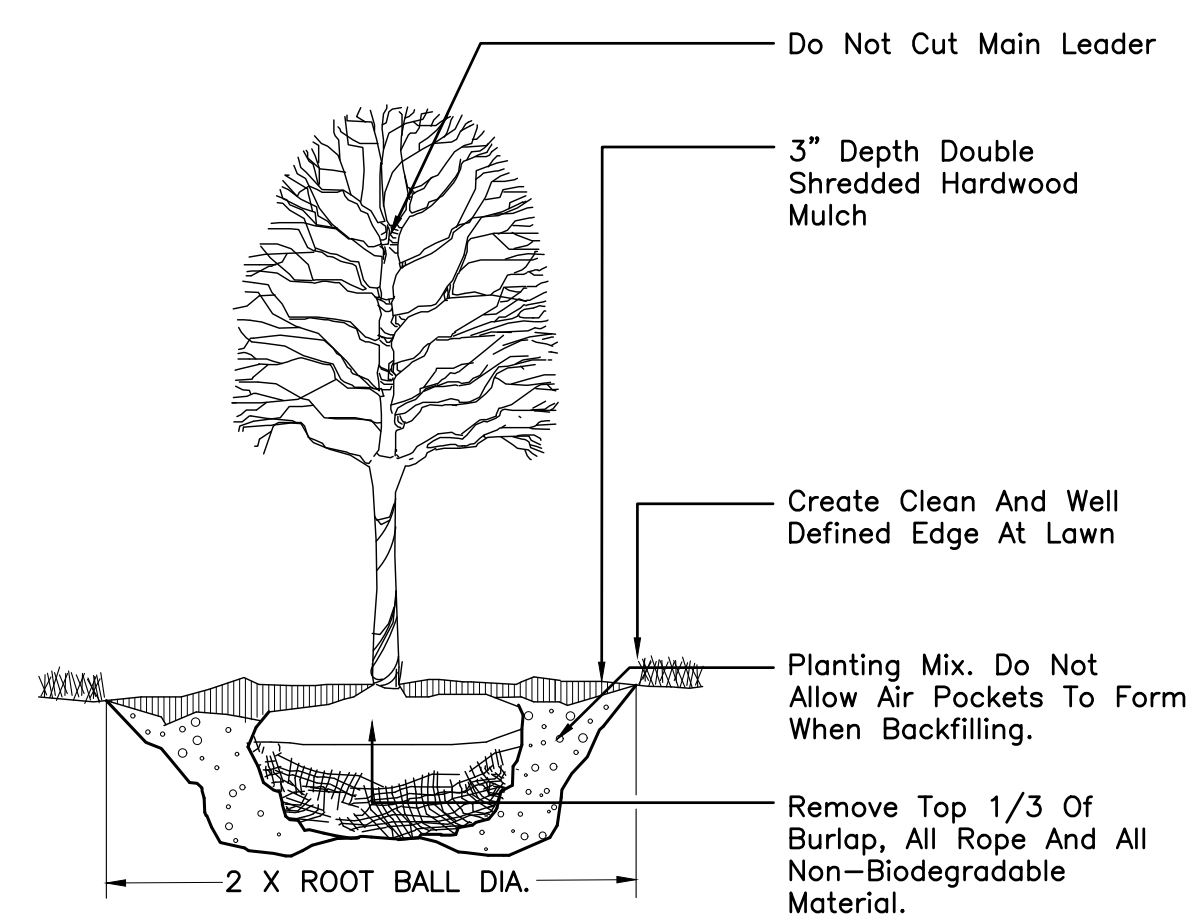

- GENERAL NOTES**
- Prior to installation, the landscape contractor shall inspect the general site conditions and verify the subgrade, elevations, utility locations and topsoil provided by general contractor. The landscape contractor shall notify the general contractor of any unsatisfactory conditions and work shall not proceed until such conditions have been corrected and are acceptable to the landscape contractor.
 - All plants shall meet or exceed standards set in the American Standard for Nursery Stock, ANSI Z60.1, current edition. All plants shall equal or exceed the measurements and sizes specified in the schedule.
 - Substitutions shall only be permitted with notification and written approval from the Owner. Substituted material shall be equivalent or greater in size than the specified plant. Substituted plants shall have the same essential characteristics and growth habit of the specified plant.
 - Confirm location of all utilities and subsurface drain lines prior to plant installation.
 - A pre-installation conference shall be conducted prior to planting operations with Owner and Contractor present.
 - Contractor may slightly field adjust plant locations as necessary to avoid utilities. Finished planting beds shall be graded to provide positive drainage.
 - Irrigation system, if applicable, shall be complete and operational prior to landscape planting.
 - Contractor shall repair all lawn areas disturbed during construction with seed and warrant a healthy, weed free lawn prior to project acceptance.
 - Seed all areas within contract limits that are not covered by paving, buildings or planting beds unless otherwise noted. Seeding shall not begin until area has received topsoil and finished grade.
 - Mulch planting beds with shredded hardwood mulch of uniform dark brown color. It shall be free of twigs, leaves, disease, pest or other material unsightly or injurious to plants. Average applied thickness shall be 3" depth. Mulch hedges in a continuous bed.
 - Planting beds shall be covered with pre-emergent herbicide applied at product specified rate unless otherwise noted.
 - Bed edge shall be smooth, consistent, hand trenched 4" deep and "V" shaped unless otherwise noted. All excavated material shall be removed from the bed edge and planting bed.
 - All planting bed edges to be smooth flowing arcs or straight lines as shown on plan. Plant locations and layout of beds shall be located by Contractor and approved by Landscape Architect prior to planting.
 - Install all plants in accordance with planting details and specifications.
 - Parking lot and street trees shall have a clear canopy height of 6' min.
 - Trees shall be placed a minimum of 3' from sidewalks and curbs.
 - Planting Mix shall be blended, manufactured soil consisting of three (3) parts topsoil, one (1) part compost, one (1) part sand. Topsoil shall be per ASTM D5268, pH range of 5.5 to 7, min. 4 percent organic material, free of stones and soil clumps 3/4 inch and larger. Compost shall be yard waste compost from an EPA rated Class IV compost facility or Com-til compost from City of Columbus Department of Public Utilities. Sand shall be per ASTM C33. Proprietary manufactured Planting Mix such as Kurtz Bros. Professional Blend or Jones SuperSoil may be used. Submit product data for review by Owner. Place Planting Mix in settled 6 inch lifts.
 - Mix Mycorrhizal Fungi into Planting Mix during placement of Planting Mix. Application rate shall be according to manufacturer's written recommendations. Mycorrhizal Fungi shall be a dry, granular inoculant containing vesicular-arbuscular mycorrhizal fungi and ectomycorrhizal fungi.
 - Excavate planting beds to a depth of 12 inches, unless otherwise indicated. Roto-til subgrade of excavation to a depth of 4 inches, unless otherwise indicated. Incorporate a 6 inch lift of planting mix into subgrade. Place remaining Planting Mix in settled 6 inch lifts.
 - Planting beds, including mulch, shall be no higher than 6 inches above adjacent grade and shall not impede surface drainage.
 - Lawn areas shall be backfilled with Planting Mix to a minimum settled thickness of 6 inches. Roto-til subgrade below lawns to a depth of 4 inches, unless otherwise indicated, prior to placement of Planting Mix.
 - All trees and shrubs shall be fertilized with controlled release tablets of 20-10-5 composition. Size and number of tablets shall be per manufacturer's instructions.
 - Composition and application rate of lawn fertilizer shall be sufficient to amend soil according to recommendations of a qualified soil testing agency. Submit soil test results and amendment recommendations to Owner. Lawn fertilizer shall be in a dry granular form.
 - Contractor to determine plant list quantities from the plan. Graphic representation on plan supersedes in case of discrepancy with quantities on schedule.
 - Any item or areas damaged during construction shall be repaired or replaced to its original condition at the contractor expense.
 - Contractor shall thoroughly water all plants at time of installation and as needed until project acceptance by owner. Contractor shall guarantee all plants installed (except annuals) for one full year from date of acceptance by the Owner. All plants shall be alive and at a vigorous rate of growth at the end of the guarantee period.
 - All annuals to be provided by Contractor from available seasonal stock.
 - Lawn seed mix shall be proportioned by weight as follows: 10 percent NudBlue or Blue Chip Kentucky Bluegrass; 10 percent Caddisshack or GoodKeeper Perennial Ryegrass; 80 percent Quest, Inferno, Arid 3 and/or Pixie Tail Fescue (select 2). Sodded lawns shall match seeded lawns. Seeding rate shall be 8 to 10 pounds per 1000 square feet.
 - Lawn seed shall not have less than 98 percent purity and shall not have less than 90 percent germination.



600 Main Street
Suite 300
North Little Rock, AR 72114
Phone: 501-758-7443

www.taggarch.com

**FINAL
DEVELOPMENT PLAN
NOT FOR
CONSTRUCTION**



Evans, Mechwart, Hambleton & Tilton, Inc.
Engineers + Surveyors + Planners + Scientists
5200 New Albany Road, Columbus, OH 43054
Phone: 614.775.4500 Fax: 614.775.3648
emht.com



**NEUROLOGICAL
TRANSITIONAL
CENTER**

DUBLIN, OH

PROJECT NAME _____

SEAL _____

REVISIONS

NO.	DESCRIPTION	DATE

**LANDSCAPE DETAILS
& NOTES**

SHEET NAME _____

DATE October 19, 2022

PROJECT NUMBER 20220237

SHEET NUMBER L0.2

**PRELIMINARY
NOT TO BE USED FOR
CONSTRUCTION**

**PLAN SET DATE
October 19, 2022**

SCHEMATIC DESIGN
NOT FOR
CONSTRUCTION



CONSULTING ENGINEERS, INC.
HERGENROTHER • FENNER • MCGUIRE • BURKETT
2828 E. Trinity Mills Road, Ste. 210 Carrollton,
Texas 75006
214-483-6202
Ohio Professional Design Firm: AFP-000615639



NEUROLOGICAL
TRANSITIONAL
CENTER

DUBLIN, OH

PROJECT NAME _____

This document is released for the purpose of interim review under the authority of:
BRIAN M. ALLUMS
OHIO P.E. No. E-88178
Date of Issue: 08/19/2022
IT IS NOT TO BE USED FOR BIDDING
CONSTRUCTION OR PERMIT PURPOSES.

SEAL _____

REVISIONS _____

NO.	DESCRIPTION	DATE

ELECTRICAL
SITE PLAN

SHEET NAME _____

DATE JULY 25, 2022

PROJECT NUMBER 149821

SHEET NUMBER **E101**

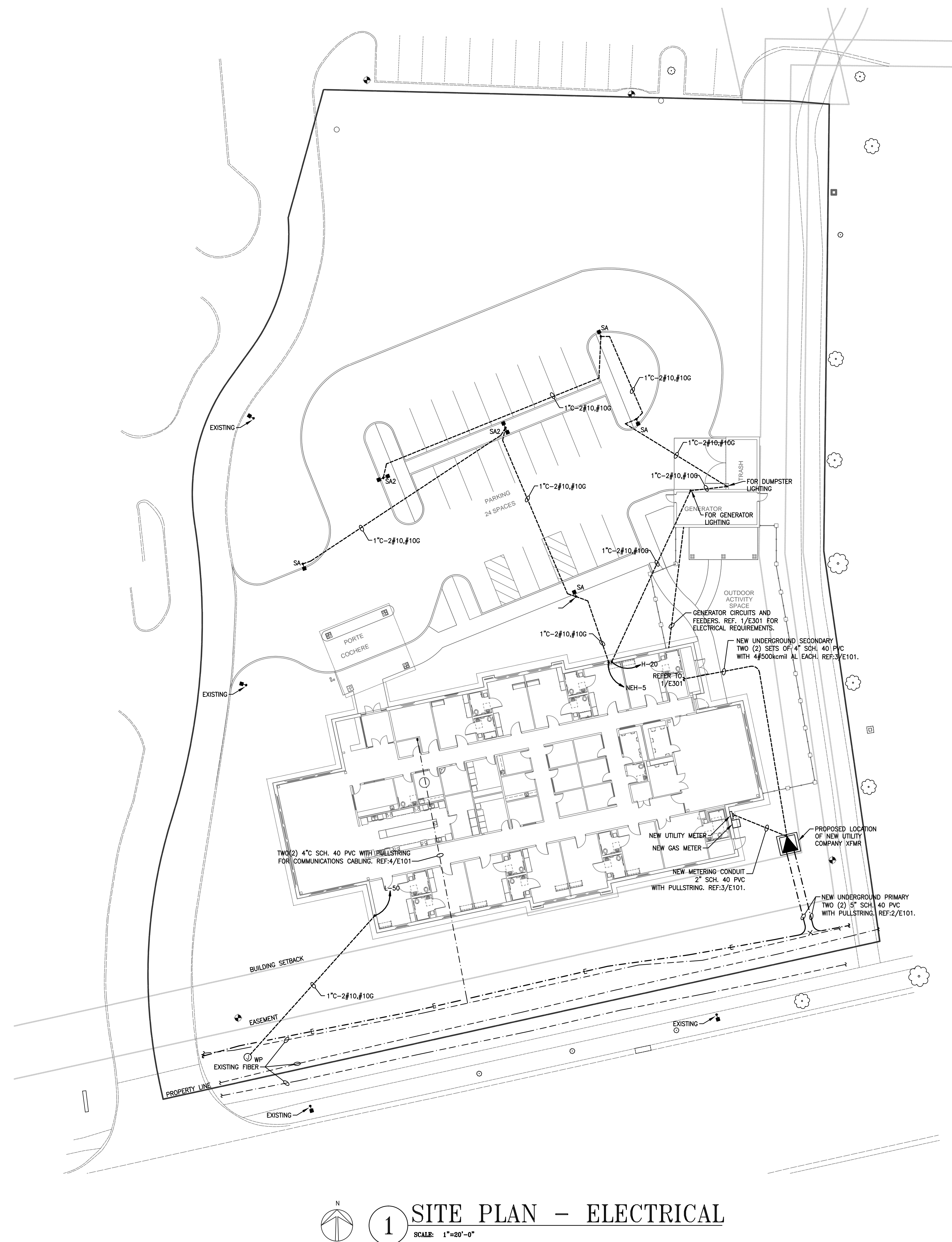

1 SITE PLAN - ELECTRICAL
SCALE: 1"=20'-0"



Date: _____ Customer: _____ **selux**

Project: SA/SA2 Qty: _____

Type: SA/SA2

Beta Pendant LED

Order Code: BPL - RSR - 1/2 - 5G105 - 40K - NA - BZ - UNV -

Pole Order Code: S35 - 18 - BZ - (Assuming 2' pole base)

BPL Series	R1 Type I Distribution	R2 Type II Distribution	R3 Type III Distribution	R4 Type IV Distribution	RSR Type V (Round)	RSS Type V (Square)
Mounting	1 Single	2C Double Cluster	3C Triple Cluster	4C Quad Cluster	W Wall Mount	P* Pendant
Light Engine	50350 100Watt	50530 100Watt	50700 100Watt	50105 100Watt		
CCT	27K 2700K	35K 3000K	35K 3000K	40 4000K	50K 5000K	
Power Cord Length	12 12'	15 15'	18 18'	20 20'	25 25'	XX XX'
Finish	WH White	BK Black	BL Silver	BZ Semi-Matte Bronze	SV Silver	SP Specify Premium Color
Voltage	UNV ¹ 120V-277V	I20 120V	240 240V	277 277V	347 ^{1,4} 347V	480 ^{1,4} 480V
Options	HS ² Head Side Mount (80°)	DM ³ Dimming (0-10V)	PCT ⁴ Photocell Sensor Energy P (for 240V)	HL50M ⁵ 50% Dimming	MS ⁶ Motion Sensor with Optional Photoeye	480 ^{1,4} 480V

Product Modifications: _____ Approvals: _____ Date: _____

Beta Pendant LED

Mounting: _____ **selux**

EPA = 1.7H (0.16m) Weight = 58lbs. (27.2kg)

EPA = 1.9H (0.20m) Weight = 65lbs. (29.9kg)

EPA = 2.1H (0.23m) Weight = 75.4lbs. (34.2kg)

Double Cluster: 80 1/2" (2050mm) x 41 1/2" (1055mm)

Tripole Cluster: 70" (1778mm) x 41 1/2" (1055mm)

Quadpole Cluster: 80 1/2" (2050mm) x 41 1/2" (1055mm)

Page 4 of 11 (Rev. 06/2022) BPL_sa_41.0

Beta Pendant LED

Mounting: _____ **selux**

EPA = 1.7H (0.16m) Weight = 58lbs. (27.2kg)

EPA = 1.7H (0.16m) Weight = 58lbs. (27.2kg)

Wall Mount: 36 1/2" (925mm) x 12" (305mm)

Single Pole Mount: 36 1/2" (925mm) x 12" (305mm)

Page 3 of 11 (Rev. 06/2022) BPL_sa_41.0

Beta Pendant LED

Mounting: _____ **selux**

EPA = 1.7H (0.16m) Weight = 58lbs. (27.2kg)

EPA = 1.7H (0.16m) Weight = 58lbs. (27.2kg)

EPA = 1.7H (0.16m) Weight = 58lbs. (27.2kg)

Pole Information: Round Straight Aluminum & Round Straight Steel Poles, Round Stepped Steel Pole

Base Cover Information: Standard Base Cover (BC1) for A35 & S35 only, Standard Base Cover (BC2) Supplied with S35

Pole Date Chart:

Pole Series	Bolt Circle	EPA Information				Height	Finish	Options
		70mph	80mph	90mph	100mph			
S635 3 1/2" Diameter Stepped Steel Pole	60"	57.6	44.3	34.6	27.5	22.8	8 ft.	WH White, BK Black, BL Semi-Matte Black, BZ Bronze, SV Silver, SP Specify Premium Color
A35 1 1/2" Diameter Straight Aluminum Pole	87 1/2"	16.1	12.2	9.4	7.3	5.9	10 to 14 ft.	MS Motion Sensor with Optional Photoeye
S35 1 1/2" Diameter Straight Steel Pole	87 1/2"	14.8	11.3	8.6	6.7	5.4	10 to 14 ft.	MS Motion Sensor with Optional Photoeye
S35S 1 1/2" Diameter Straight Steel Pole	87 1/2"	15.4	11.4	8.6	6.5	4.9	10 to 14 ft.	MS Motion Sensor with Optional Photoeye
A35 1 1/2" Diameter Straight Aluminum Pole	87 1/2"	11.4	8.6	6.5	4.9	3.9	10 to 14 ft.	MS Motion Sensor with Optional Photoeye
S35 1 1/2" Diameter Straight Steel Pole	87 1/2"	9.9	7.3	5.4	4.0	3.1	12 to 14 ft.	MS Motion Sensor with Optional Photoeye
A35 1 1/2" Diameter Straight Aluminum Pole	87 1/2"	9.1	6.7	4.9	3.6	2.8	12 to 14 ft.	MS Motion Sensor with Optional Photoeye
S635 3 1/2" Diameter Stepped Steel Pole	60"	31.7	24.2	18.6	14.6	11.9	14 to 16 ft.	MS Motion Sensor with Optional Photoeye
S35 1 1/2" Diameter Straight Aluminum Pole	87 1/2"	6.0	5.8	4.2	3.0	2.2	14 to 16 ft.	MS Motion Sensor with Optional Photoeye
S35 1 1/2" Diameter Straight Steel Pole	87 1/2"	2.3	2.3	1.8	1.7	1.9	14 to 16 ft.	MS Motion Sensor with Optional Photoeye
S35S 1 1/2" Diameter Straight Steel Pole	87 1/2"	21.7	15.8	12.3	9.6	7.6	14 to 16 ft.	MS Motion Sensor with Optional Photoeye
A35 1 1/2" Diameter Straight Aluminum Pole	87 1/2"	4.9	3.2	2.2	1.4	N/A	14 to 16 ft.	MS Motion Sensor with Optional Photoeye
S35 1 1/2" Diameter Straight Steel Pole	87 1/2"	4.4	2.8	1.9	N/A	N/A	14 to 16 ft.	MS Motion Sensor with Optional Photoeye

Page 5 of 11 (Rev. 06/2022) BPL_sa_41.0

GWG3 ARCHITECTURE, PLLC

600 Main Street Suite 300 North Little Rock, AR 72114 Phone: 501-758-7443

www.taggarch.com

SCHEMATIC DESIGN NOT FOR CONSTRUCTION

HPMB CONSULTING ENGINEERS, INC.
2828 E. Trinity Mills Road, Ste. 210 Carrollton, Texas 75006 214-483-6302 Ohio Professional Design Firm AFP-000615639

Select MEDICAL

NEUROLOGICAL TRANSITIONAL CENTER

DUBLIN, OH

PROJECT NAME _____

This document is released for the purpose of interim review under the authority of: **BRIAN M. ALLUMS**, CHIO P.E. No. E-88178 Date of Issue: 08/19/2022 IT IS NOT TO BE USED FOR BIDDING, CONSTRUCTION OR PERMIT PURPOSES.

SEAL _____

REVISIONS:

NO.	DESCRIPTION	DATE

SITE PLAN PHOTOMETRICS

SHEET NAME _____

DATE: JULY 25, 2022

PROJECT NUMBER: 149821

SHEET NUMBER: **E102**

CONDITIONAL USE
PERMIT DRAWINGS -
NOT FOR
CONSTRUCTION



NEUROLOGICAL
TRANSITIONAL
CENTER

DUBLIN, OH

PROJECT NAME

SEAL

REVISIONS

NO.	DESCRIPTION	DATE

FLOOR PLAN

SHEET NAME

DATE SEPTEMBER 14, 2022

PROJECT NUMBER 149821

SHEET NUMBER **A1.0**

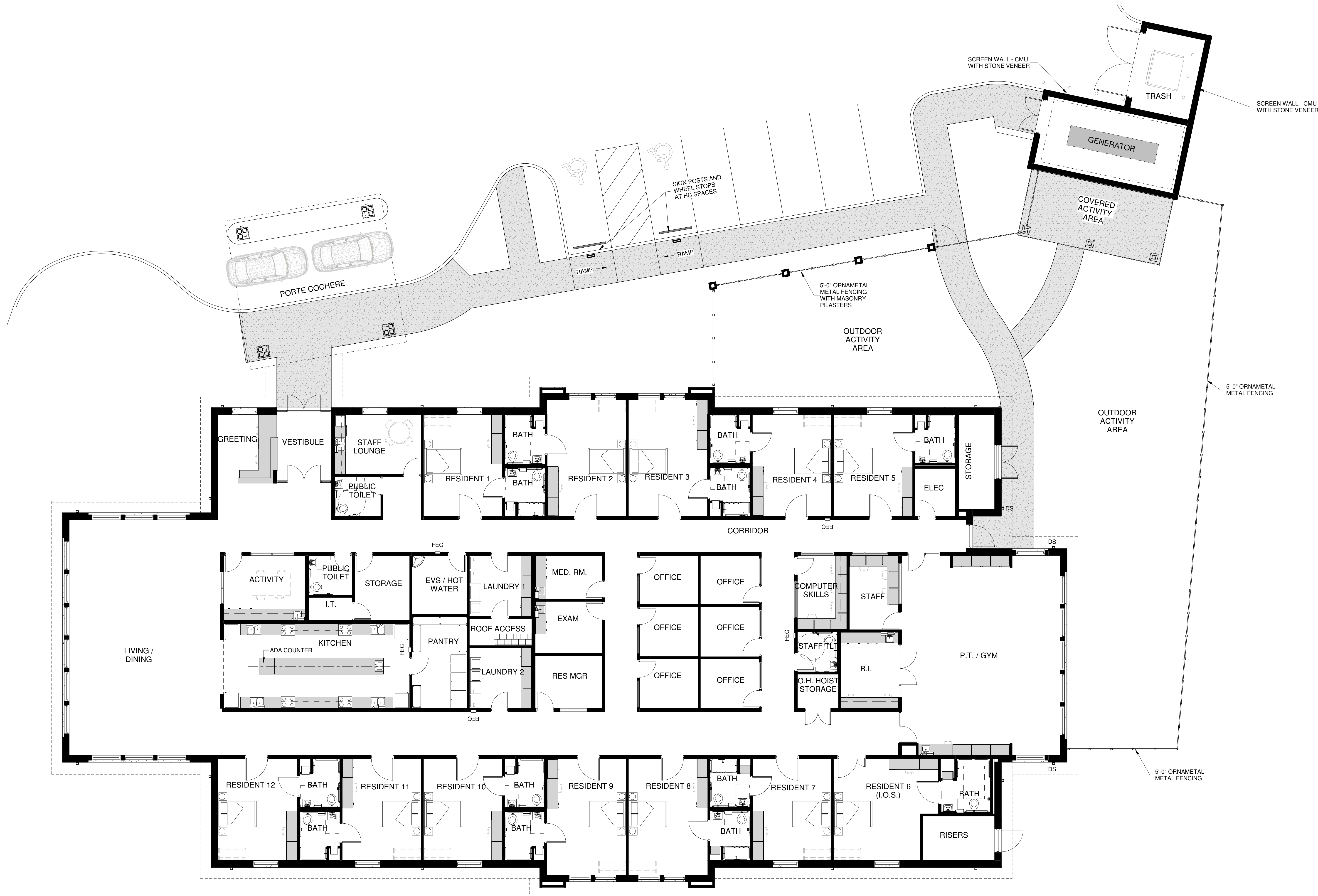

NORTH
1 FLOOR PLAN - BLDG. AREA 13,745 SQ.FT.
1/8" = 1'-0"

CONDITIONAL USE
PERMIT DRAWINGS -
NOT FOR
CONSTRUCTION



NEUROLOGICAL
TRANSITIONAL
CENTER

DUBLIN, OH

PROJECT NAME

SEAL

REVISIONS

NO.	DESCRIPTION	DATE

ROOF PLAN

SHEET NAME

DATE SEPTEMBER 14, 2022

PROJECT NUMBER 149821

SHEET NUMBER **A1.1**

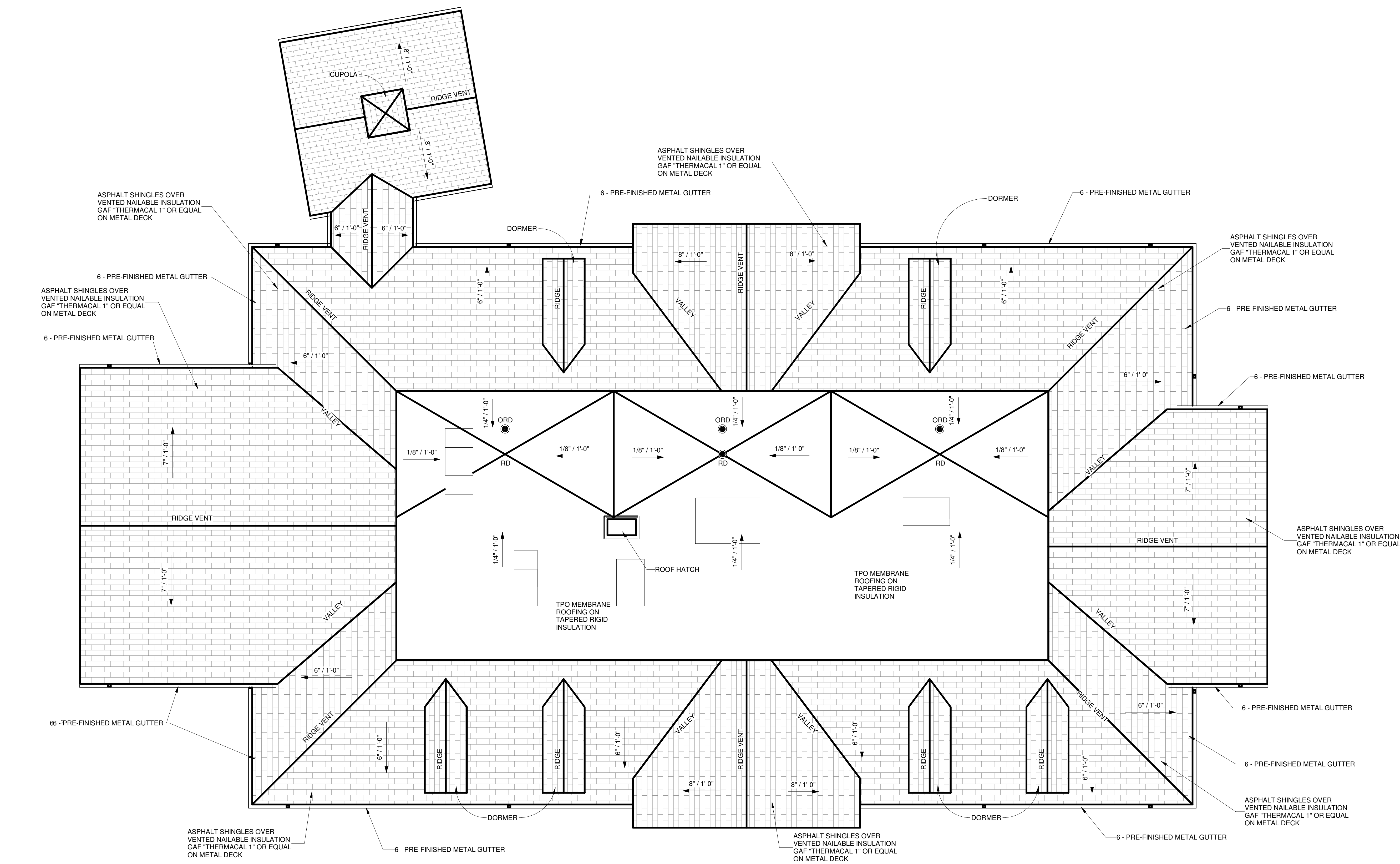

1 ROOF PLAN
1/8" = 1'-0"



NO.	DESCRIPTION	DATE

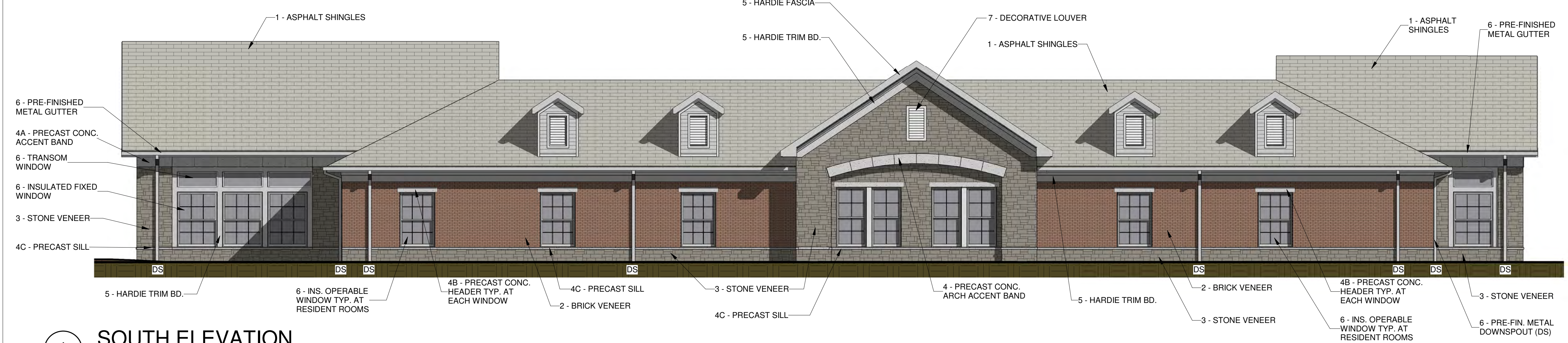

1 SOUTH ELEVATION
1/8" = 1'-0"

10 FENCE ELEVATION
3/8" = 1'-0"

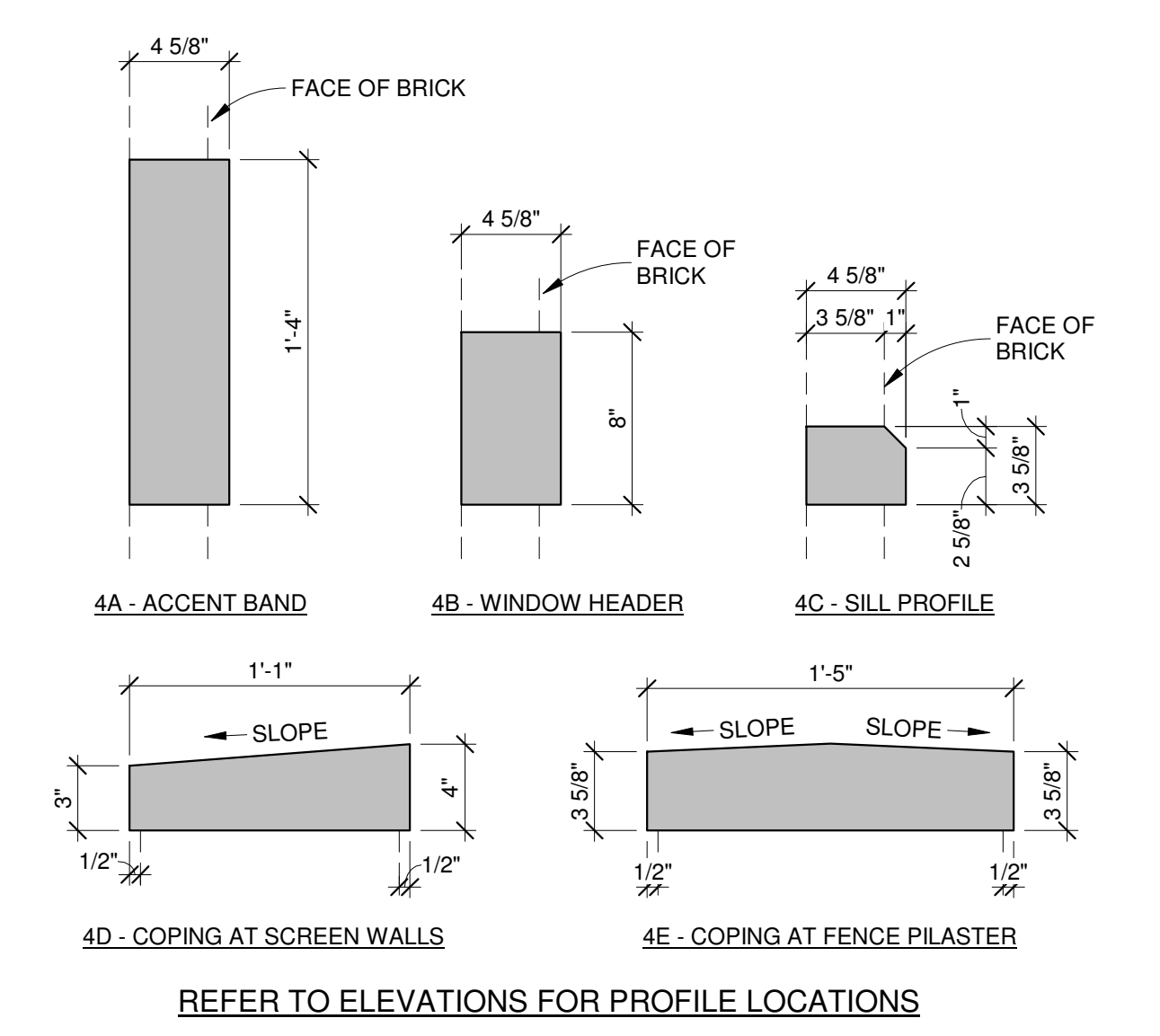

REFER TO ELEVATIONS FOR PROFILE LOCATIONS

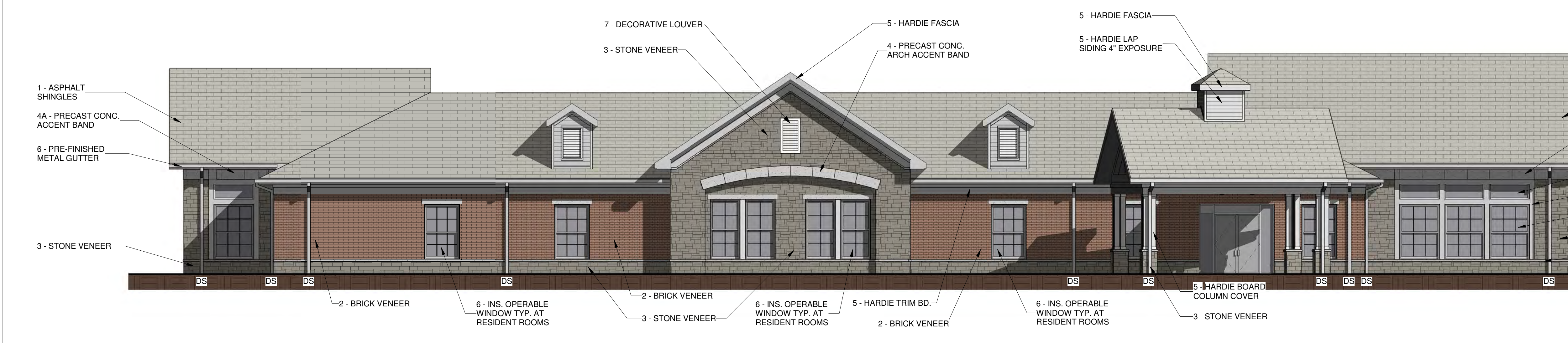

2 NORTH ELEVATION
1/8" = 1'-0"

11 PRECAST CONC. SHAPES
1 1/2" = 1'-0"

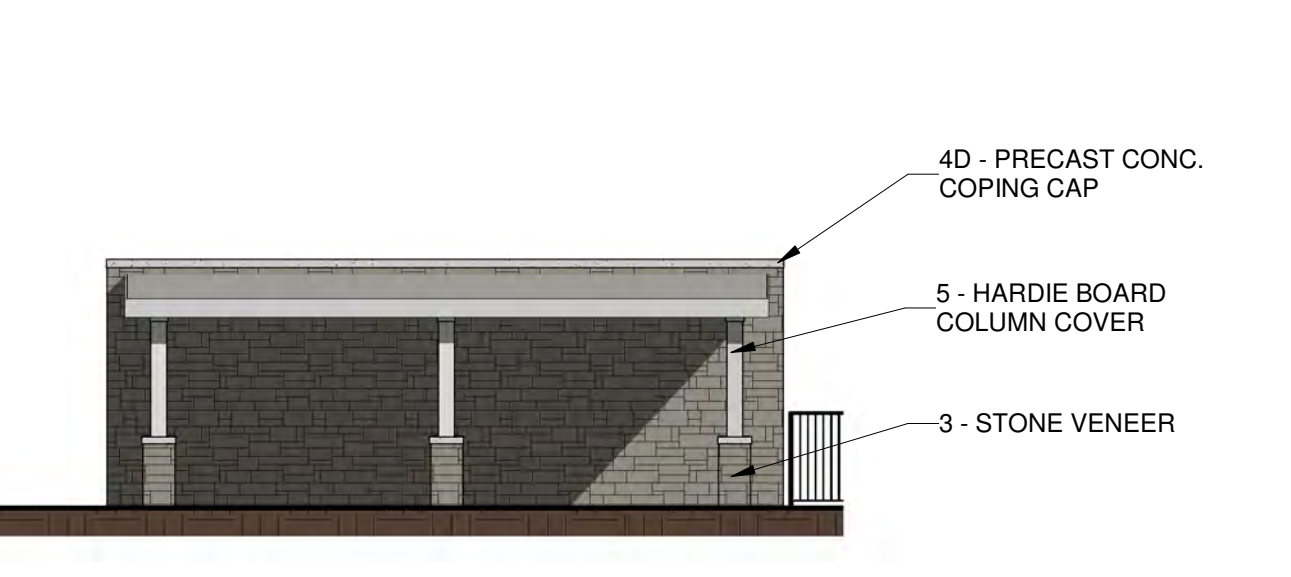

REFER TO ELEVATIONS FOR PROFILE LOCATIONS

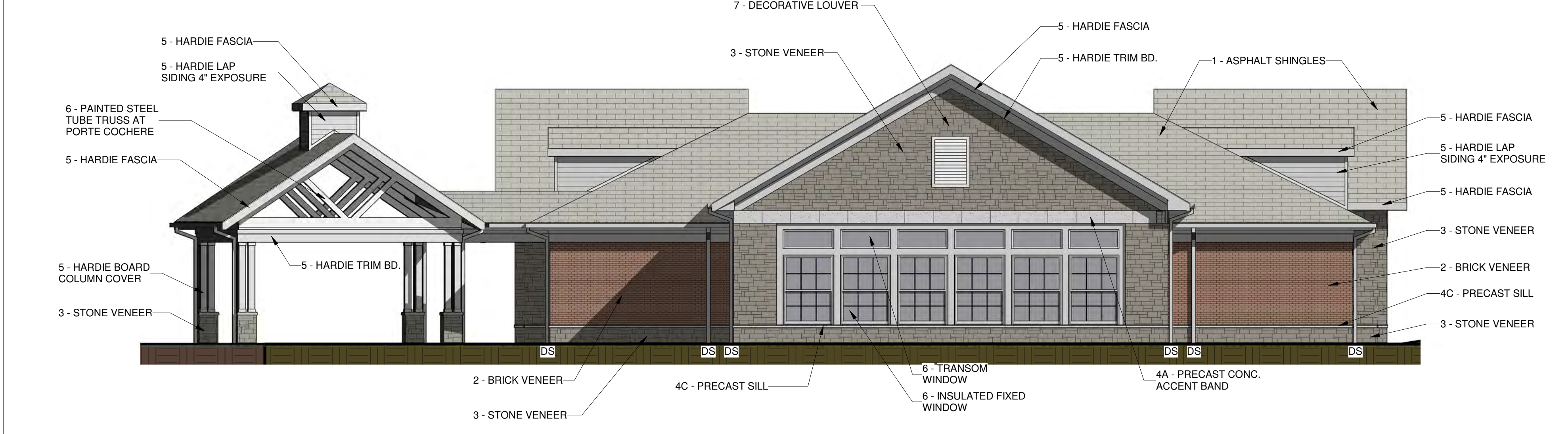

3 WEST ELEVATION
1/8" = 1'-0"

5 TYP. DORMER ELEVATION
3/8" = 1'-0"

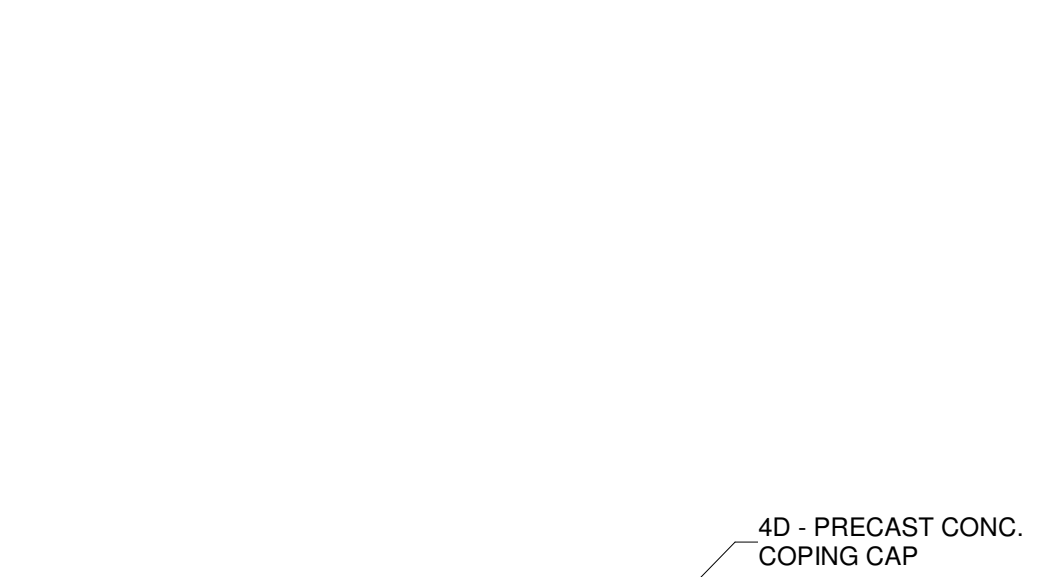

6 GEN ENCLOSURE SOUTH ELEVATION
1/8" = 1'-0"

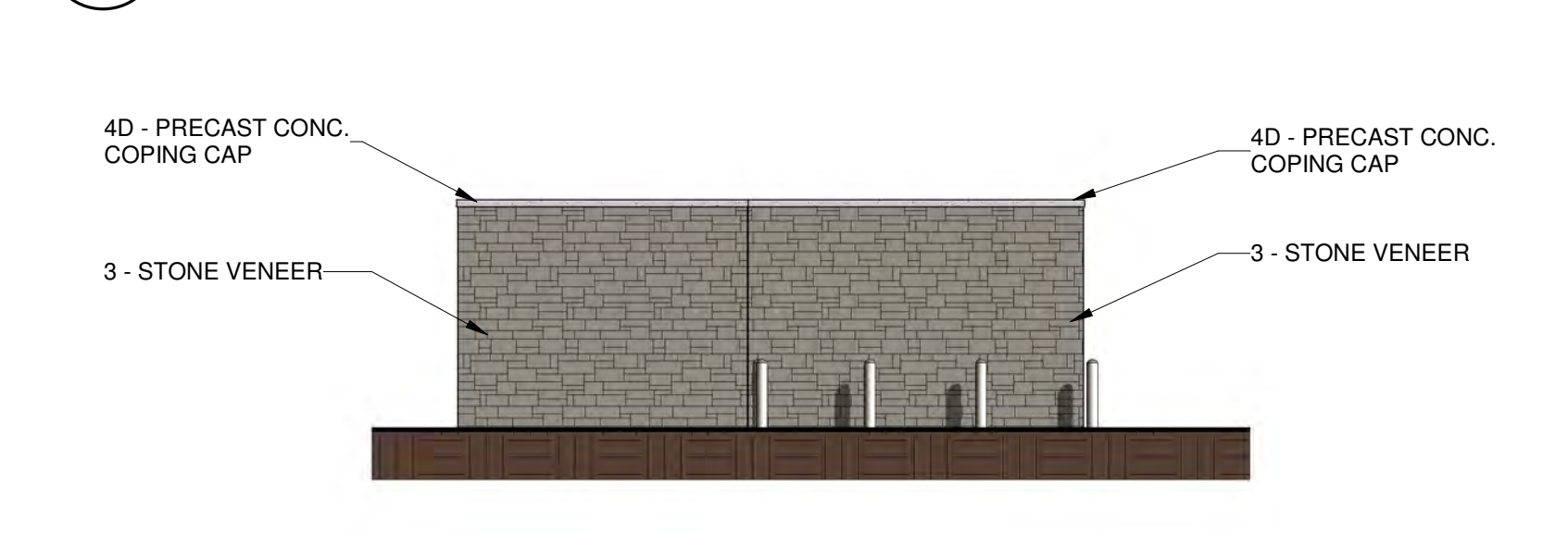

7 GEN/TRASH ENCLOSURE NORTH ELEVATION
1/8" = 1'-0"

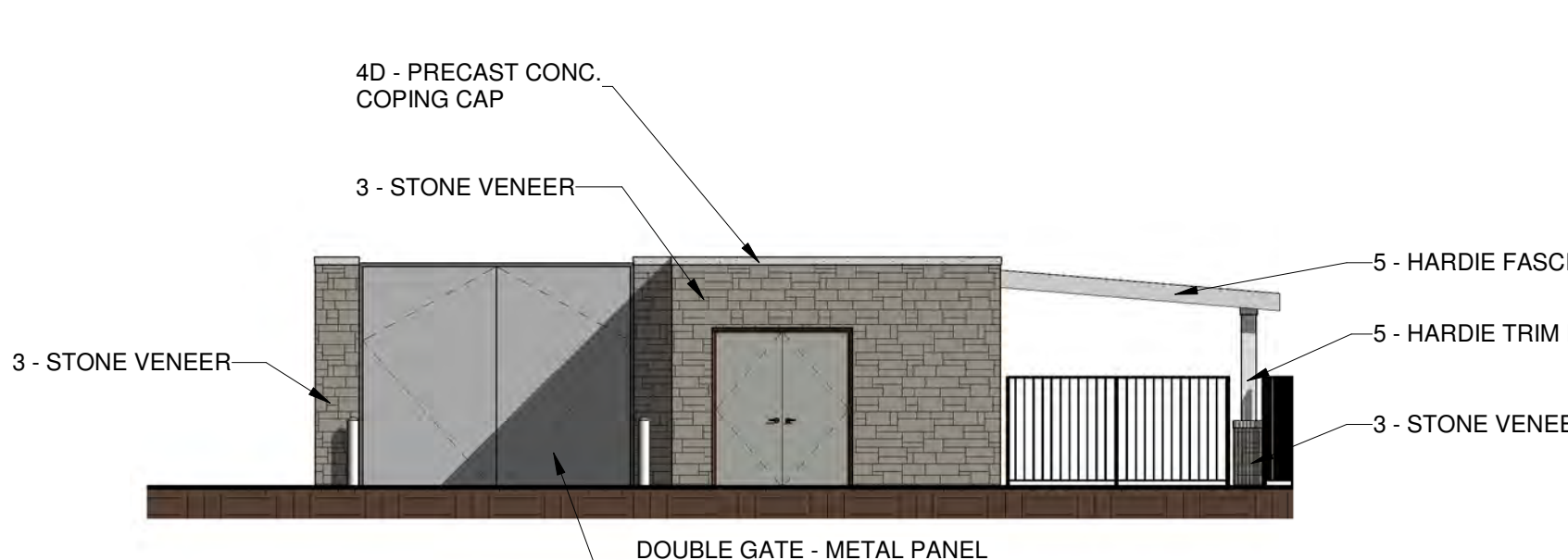

9 GEN/TRASH ENCLOSURE WEST ELEVATION
1/8" = 1'-0"

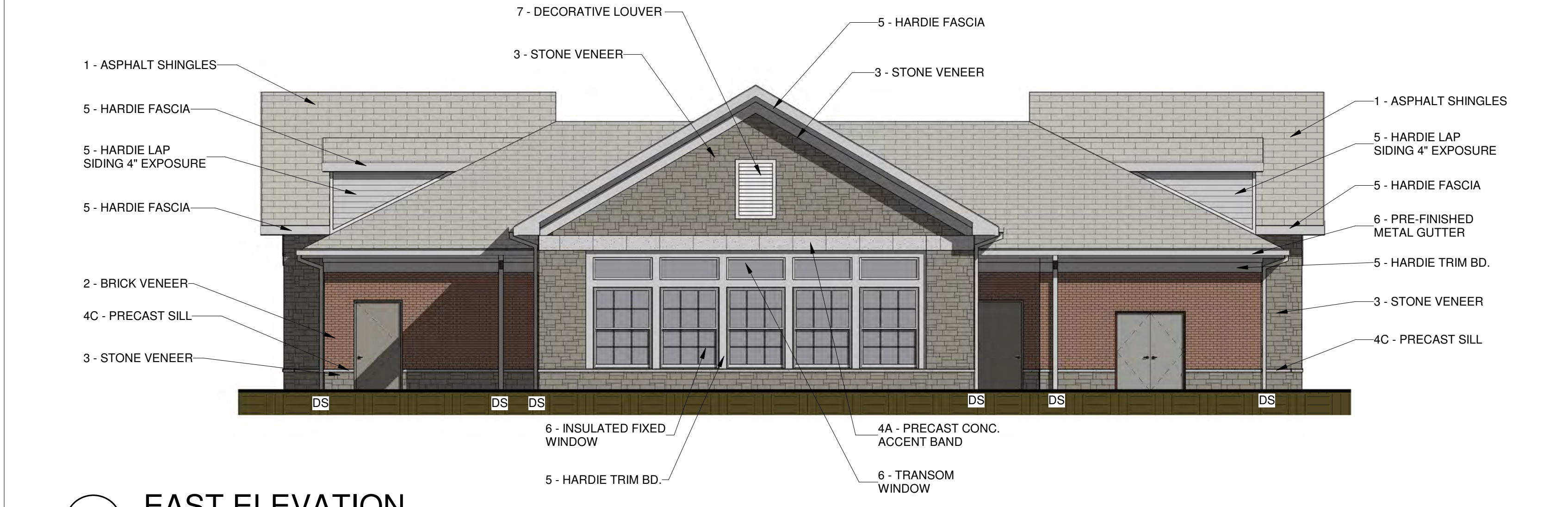

4 EAST ELEVATION
1/8" = 1'-0"

8 GEN/TRASH ENCLOSURE EAST ELEVATION
1/8" = 1'-0"

